



US00D377781S

United States Patent [19]

[11] **Patent Number: Des. 377,781**

Burgland

[45] **Date of Patent: **Feb. 4, 1997**

[54] **VEHICLE-MOUNTABLE LUGGAGE CARRIER**

[76] Inventor: **Dale C. Burgland**, 8 W. 44 St., Kearney, Nebr. 68847

[**] Term: **14 Years**

[21] Appl. No.: **46,080**

[22] Filed: **Nov. 7, 1995**

[52] **U.S. Cl.** **D12/409**

[58] **Field of Search** D12/409, 410, D12/416; D3/217, 230, 231, 272; 224/32 A, 32 R, 30 R, 30 A, 35, 40-42

[56] **References Cited**

U.S. PATENT DOCUMENTS

D. 307,733	5/1990	Kushituni	D12/409
D. 309,214	7/1990	Haugland	D3/272
D. 338,779	8/1993	Albert	D12/416
D. 348,041	6/1994	Lovett	D12/409
D. 360,182	7/1995	Lovett	D12/409
D. 365,322	12/1995	Hub	D12/409
4,359,233	11/1982	Jackson et al.	224/32 R
4,469,256	9/1984	McEwen	224/32 R
4,580,706	4/1986	Jackson et al.	D12/409

OTHER PUBLICATIONS

J C Whitney & Co Catalog, No. 575C, ©1995, p. 221, the tank-mount travel kits for Harley Davidson Fl motorcycles 80-94.

Bike Nashbar, Summer 1995, p. 71, the Nashbar ATB Handlebar bag and Expanding Rack Trunk.

Primary Examiner—Melody N. Brown

Attorney, Agent, or Firm—Terry M. Gernstein

[57] **CLAIM**

The ornamental design for a vehicle-mountable luggage carrier, as shown and described.

DESCRIPTION

FIG. 1 is a front, top and side perspective view of the vehicle-mountable luggage carrier showing my new design; FIG. 2 is a front end elevational view thereof; FIG. 3 is a rear end elevational view thereof; FIG. 4 is a side elevational view thereof, the side opposite being a mirror image of the side shown in FIG. 4; FIG. 5 is a top plan view thereof; FIG. 6 is a bottom plan view thereof; and, FIG. 7 is a perspective view thereof shown on a vehicle with the vehicle being shown in broken lines for illustrative purposes only and forming no part of the claimed design.

1 Claim, 5 Drawing Sheets

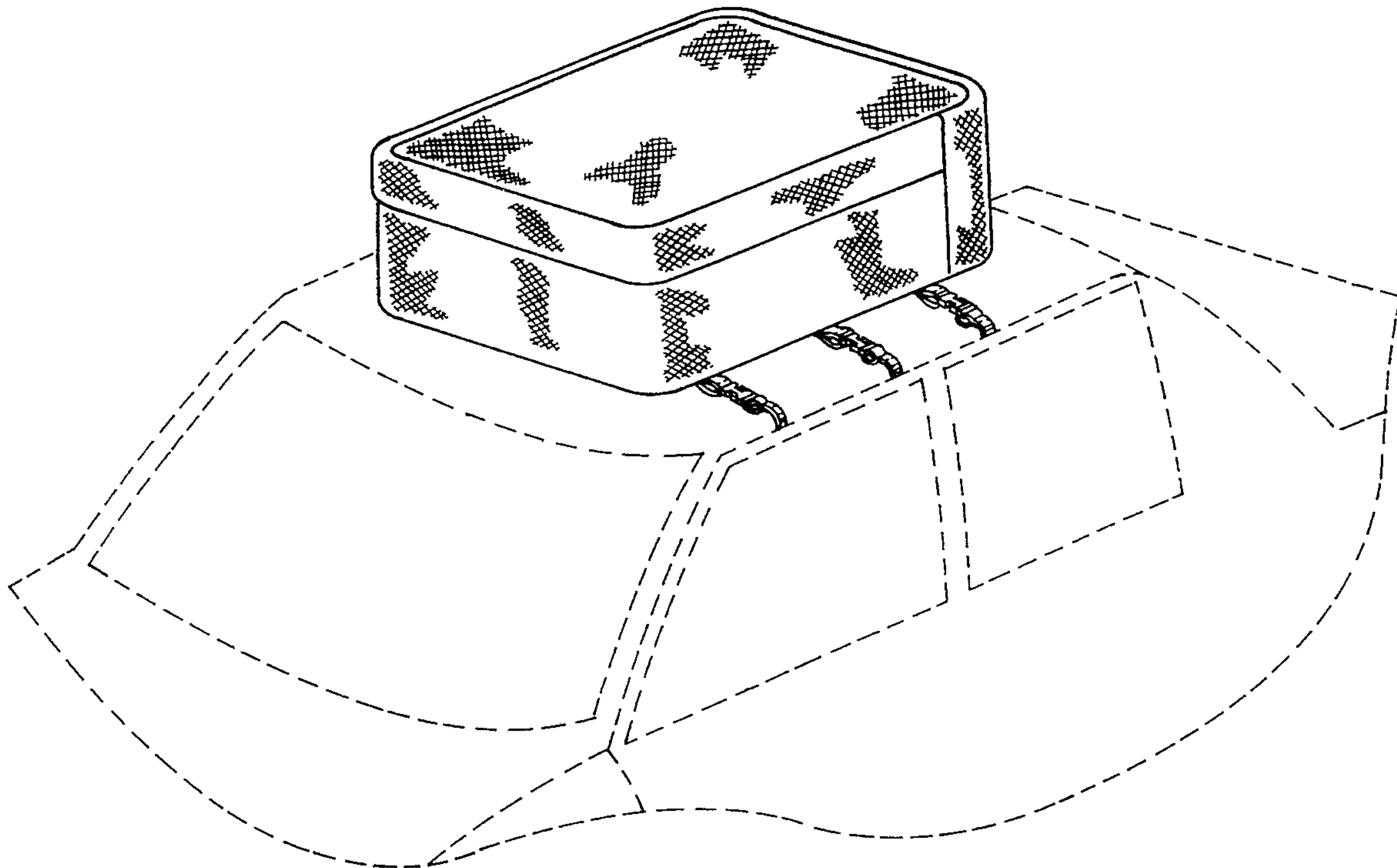

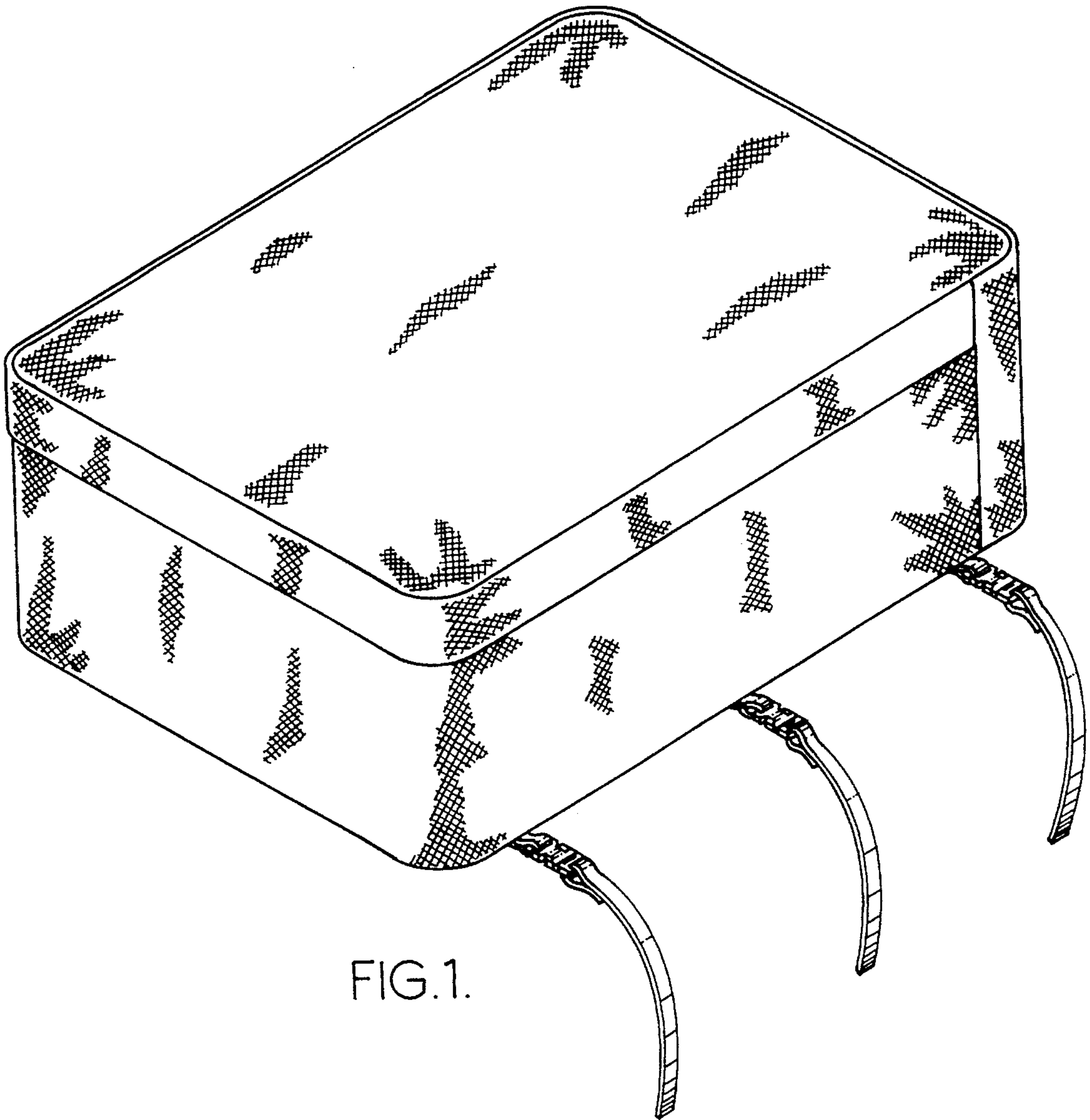

FIG. 1.

FIG. 6.

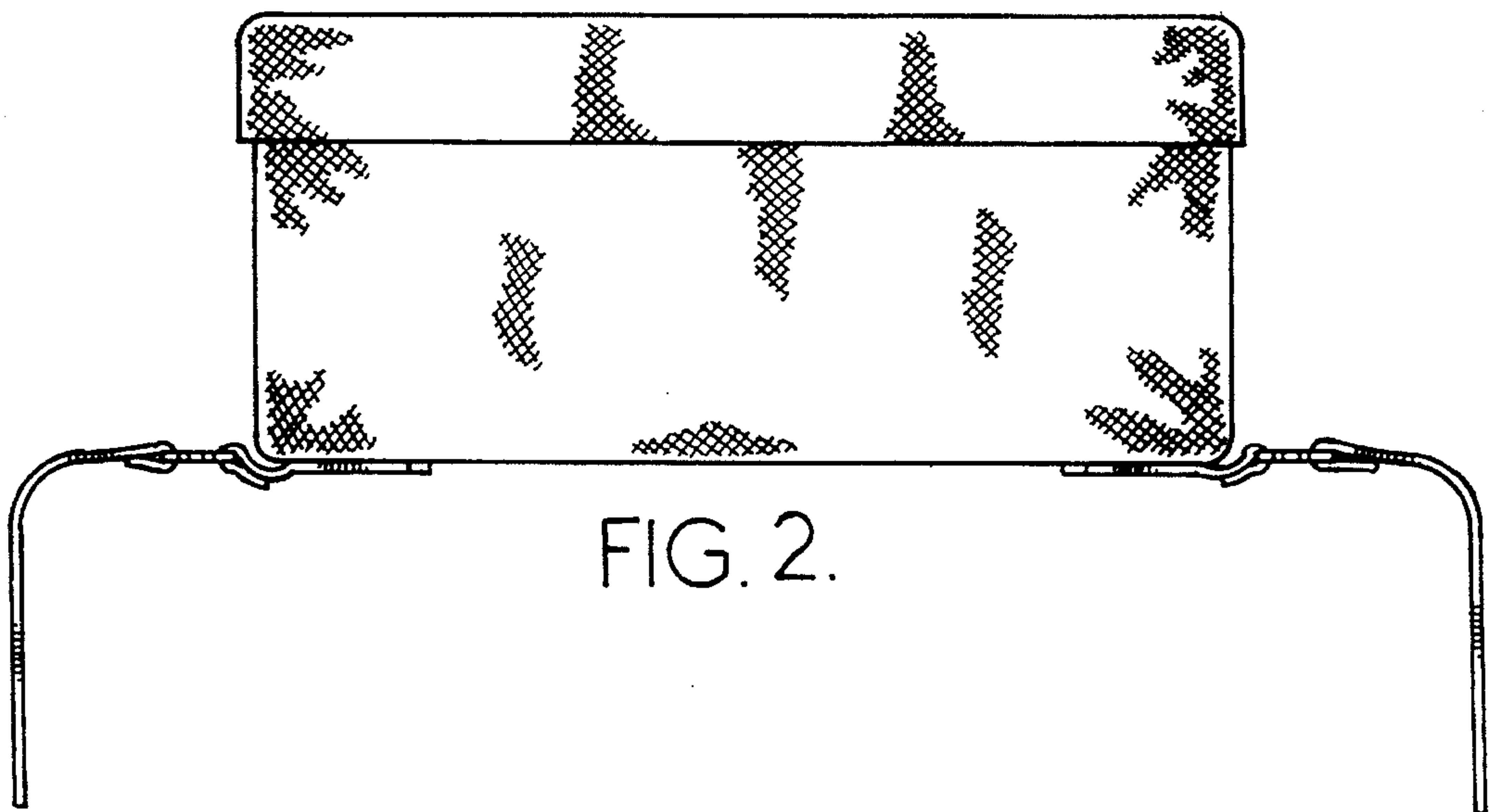
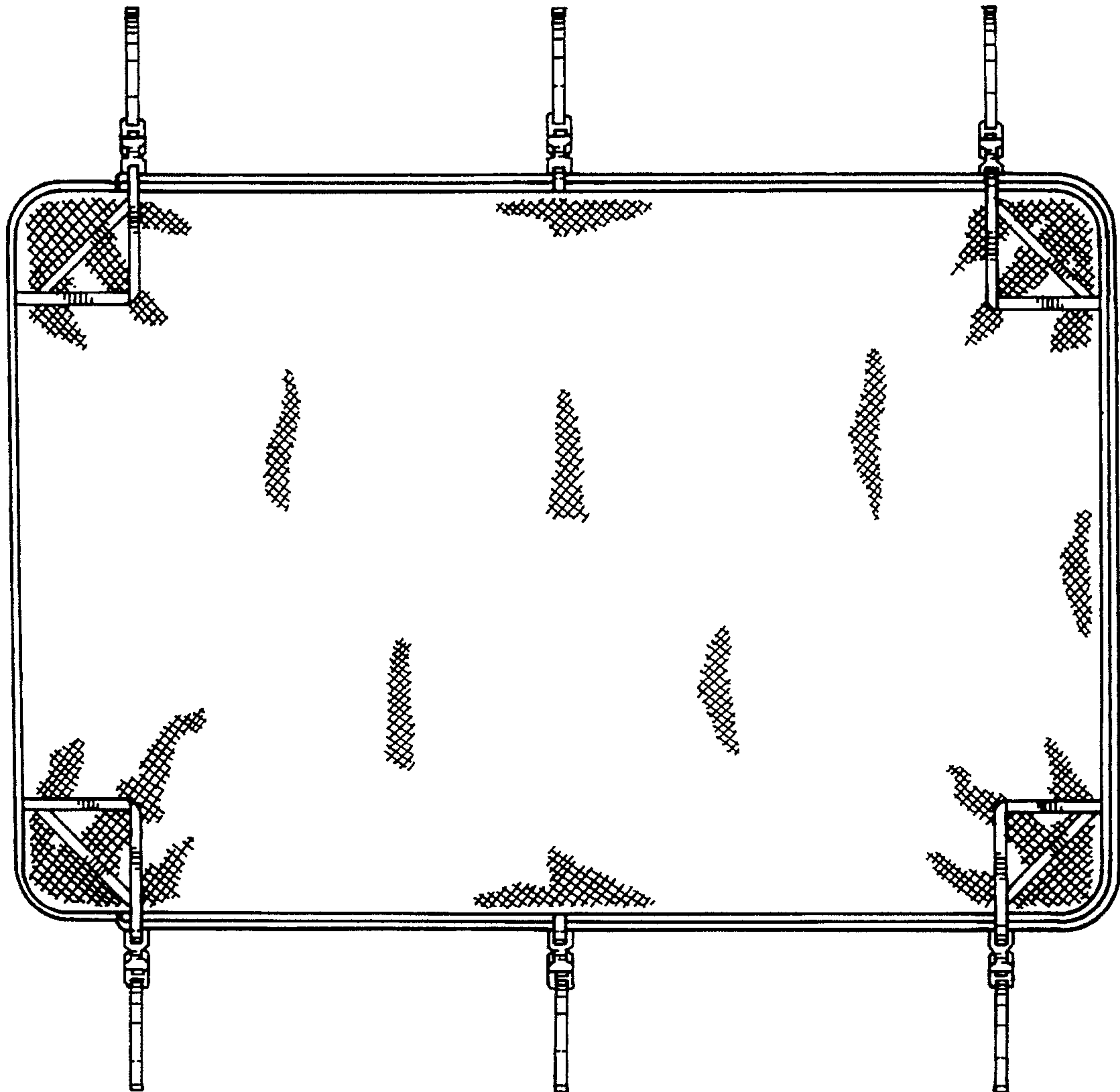

FIG. 2.

FIG. 3.

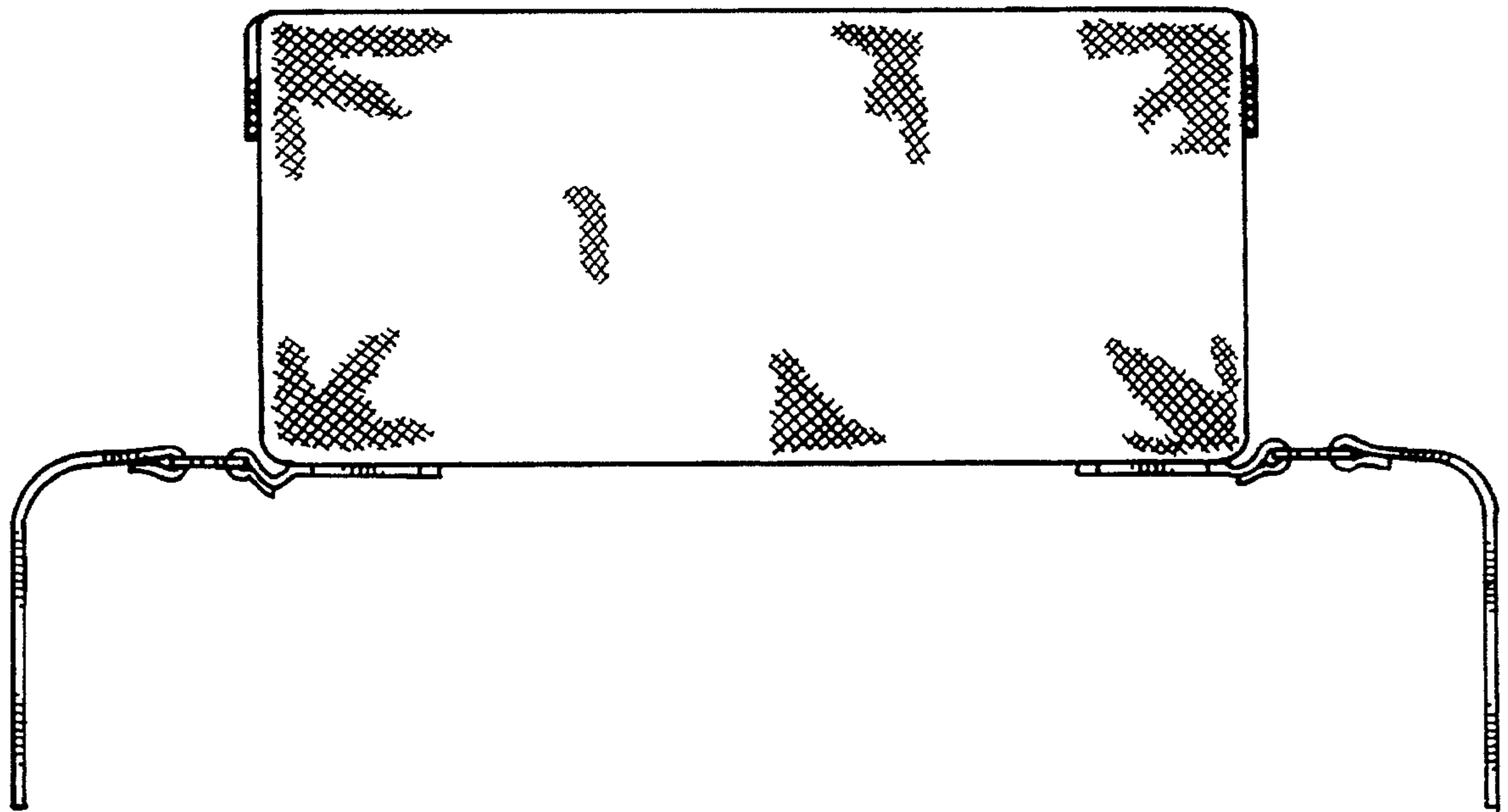

FIG. 5.

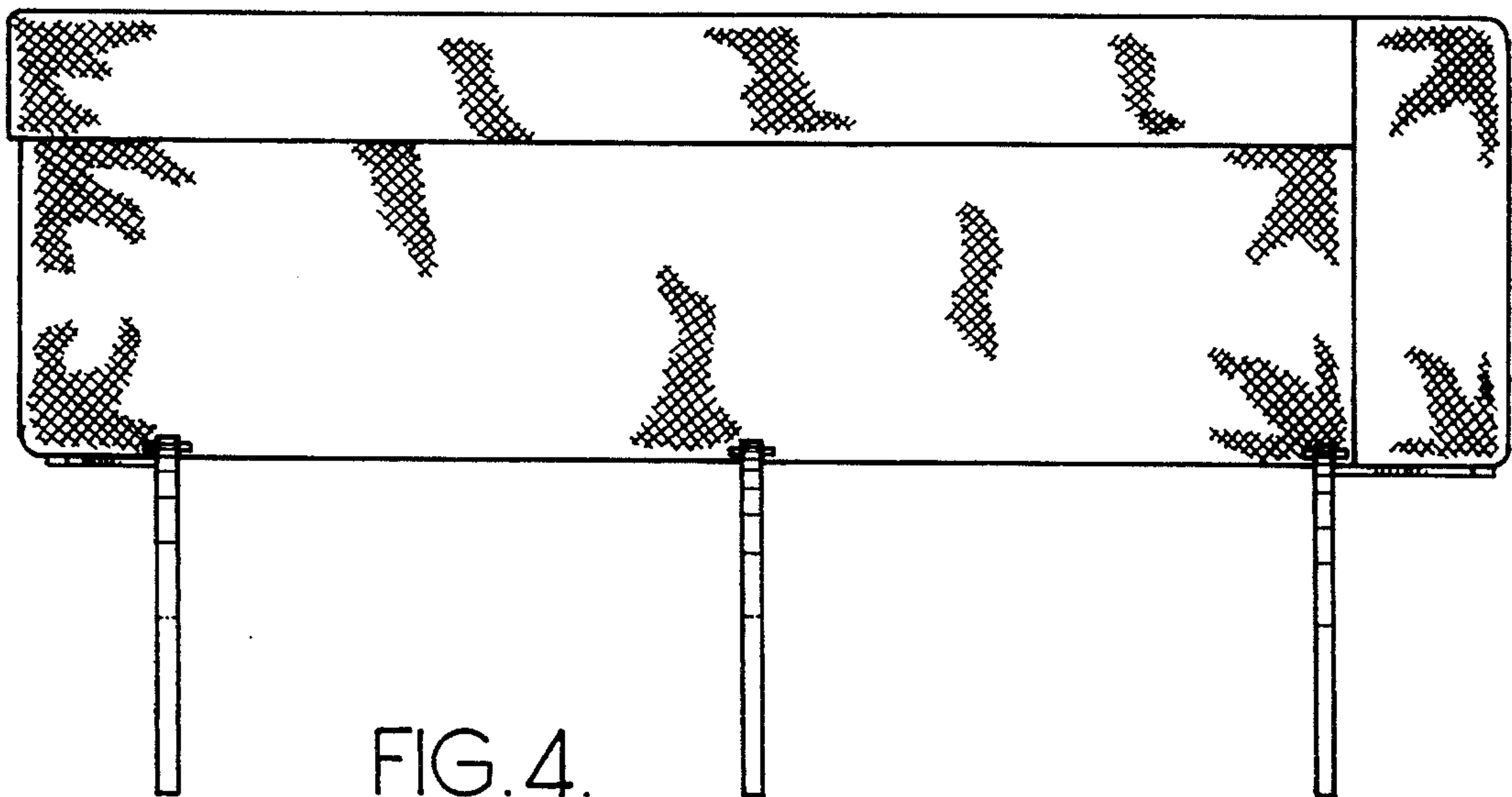
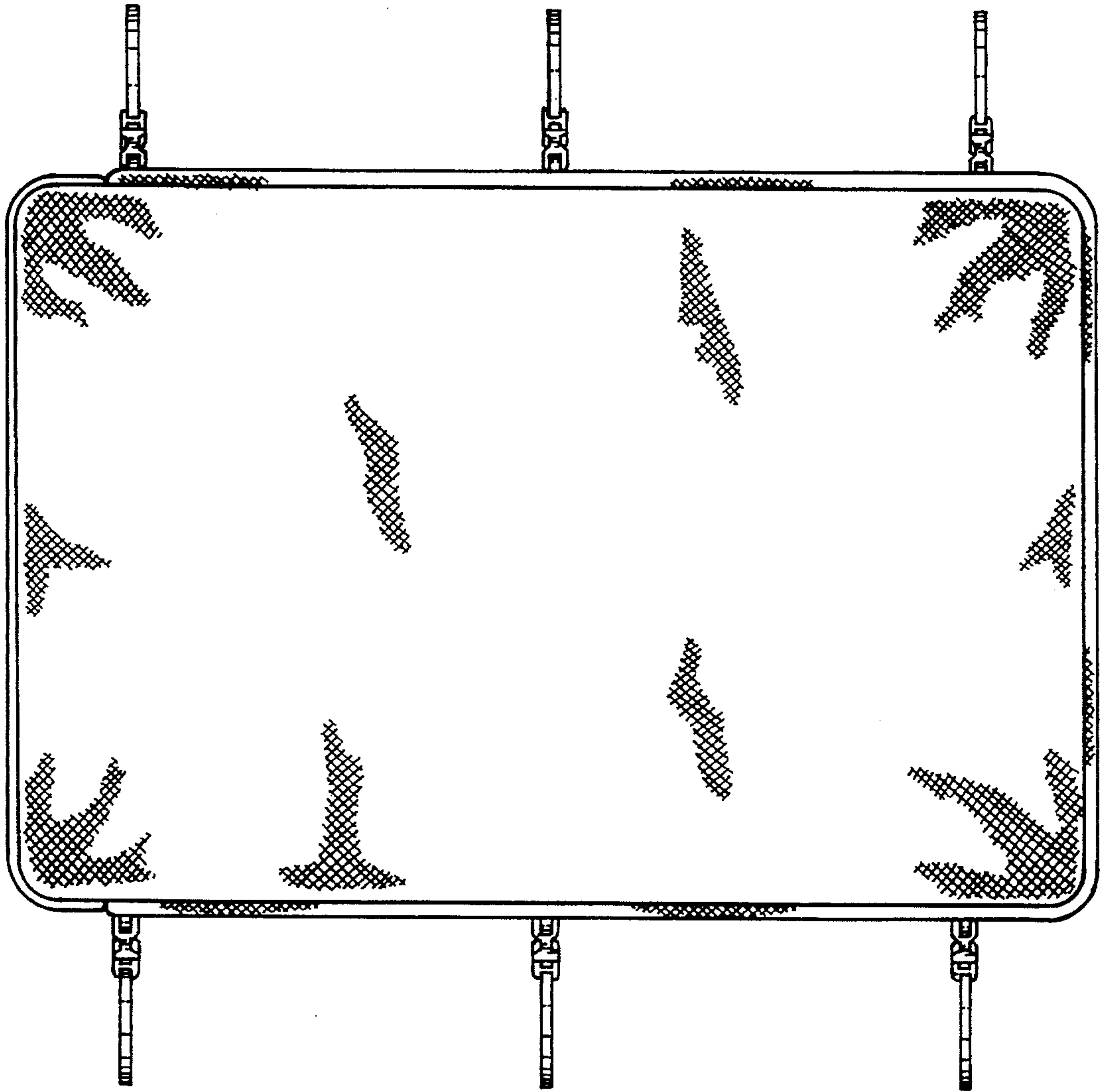

FIG. 4.

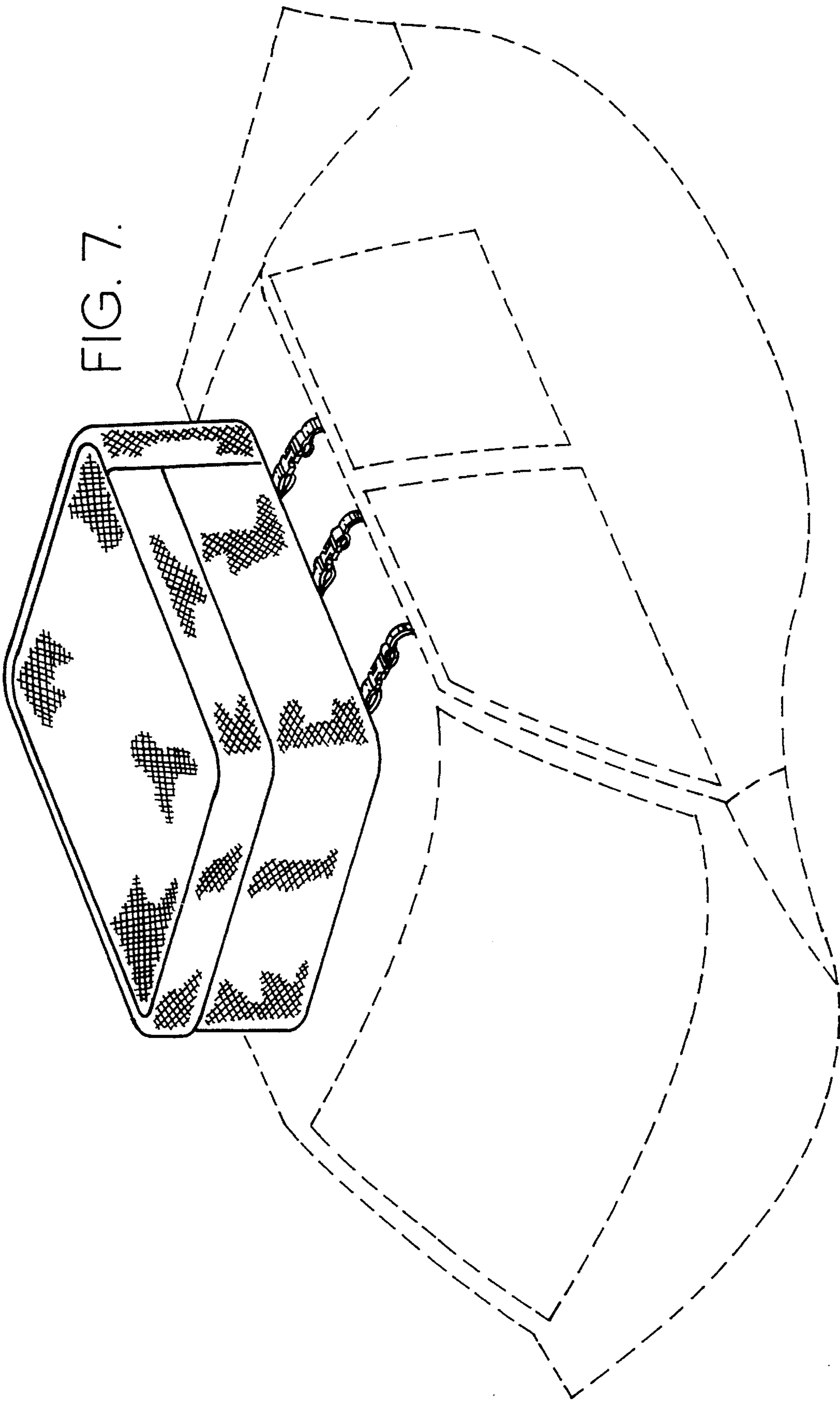

FIG. 7.