



US00D377759S

United States Patent [19] Hot

[11] Patent Number: **Des. 377,759**

[45] Date of Patent: ****Feb. 4, 1997**

[54] **COMBINED CONTAINER AND CAP**

[75] Inventor: **Hervé Hot**, Marceuil les Meaux, France

[73] Assignee: **Motul S.A.**, Aubervilliers, France

[**] Term: **14 Years**

[21] Appl. No.: **48,570**

[22] Filed: **Jan. 4, 1996**

[30] **Foreign Application Priority Data**

Jul. 7, 1995 [FR] France 95 3772

[52] U.S. Cl. **D9/520**; D9/528

[58] Field of Search D9/528, 527, 523,
D9/570, 520; 215/385, 396, 398, 382-384

[56] **References Cited**

U.S. PATENT DOCUMENTS

| | | | | |
|------------|--------|----------|-------|--------|
| D. 195,064 | 4/1963 | Dike | | D9/523 |
| D. 211,508 | 6/1968 | Anderson | | D9/528 |
| D. 220,679 | 5/1971 | Finkel | | D9/523 |
| D. 309,100 | 7/1990 | Beaver | | D9/523 |

| | | | | |
|------------|---------|----------------|-------|----------|
| D. 340,645 | 10/1993 | Bridges et al. | | D9/528 |
| D. 346,331 | 4/1994 | Jaramillo | | D9/528 X |
| D. 347,387 | 5/1994 | Bridger et al. | | D9/528 X |
| D. 358,993 | 6/1995 | Hot | | D9/523 |

Primary Examiner—Lucy Lieberman
Attorney, Agent, or Firm—Kuhn and Muller

[57] **CLAIM**

The ornamental design for combined container and cap, as shown and described.

DESCRIPTION

FIG. 1 is a rear perspective view of the combined container and cap;
FIG. 2 is a front perspective view thereof;
FIG. 3 is a top plan view thereof;
FIG. 4 is a left side elevational view thereof, the right side being a mirror image thereof;
FIG. 5 is a front elevational view thereof;
FIG. 6 is a rear elevational view thereof; and,
FIG. 7 is a bottom view thereof.

1 Claim, 3 Drawing Sheets

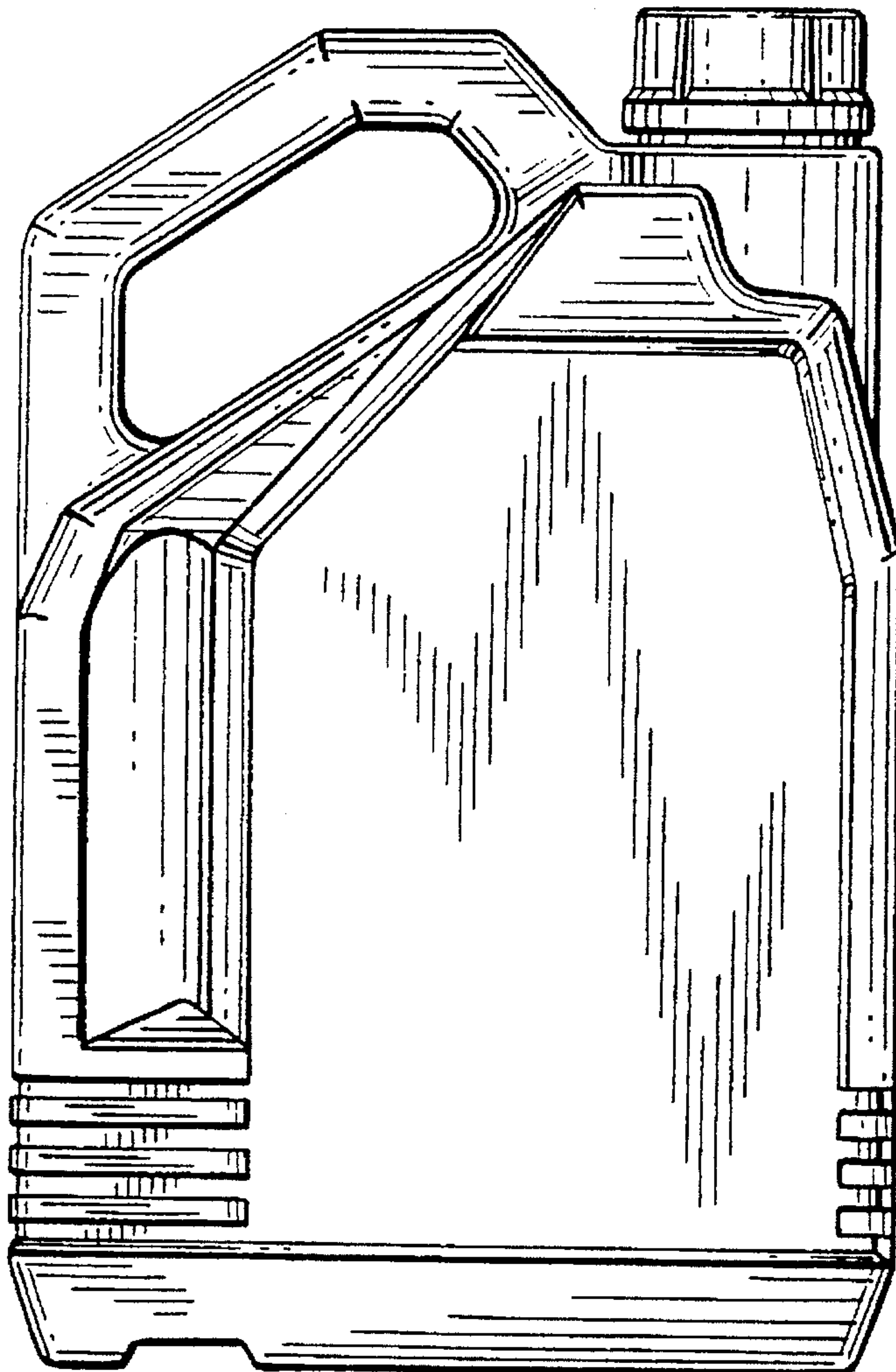

FIG. 2

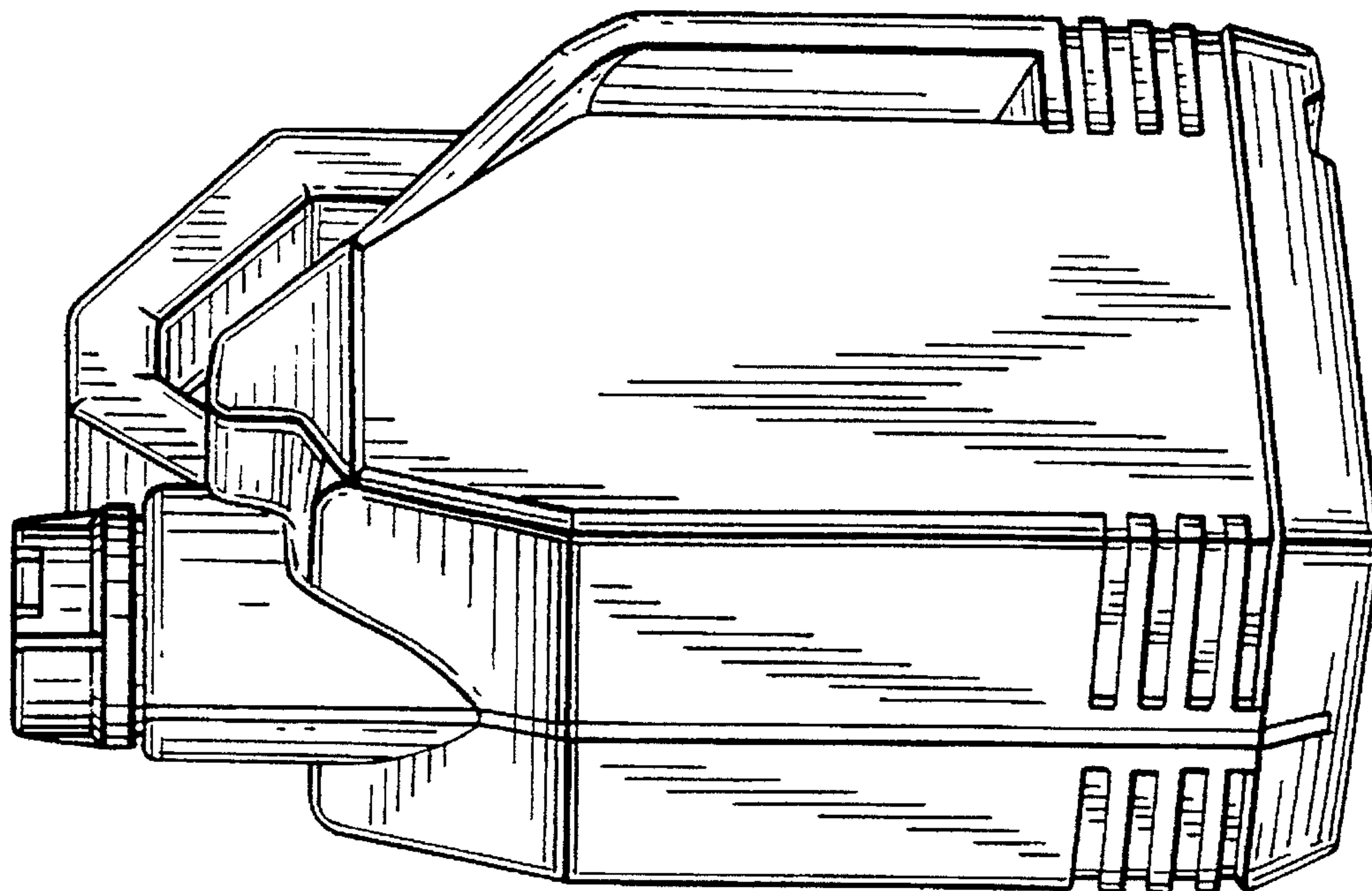

FIG. 1

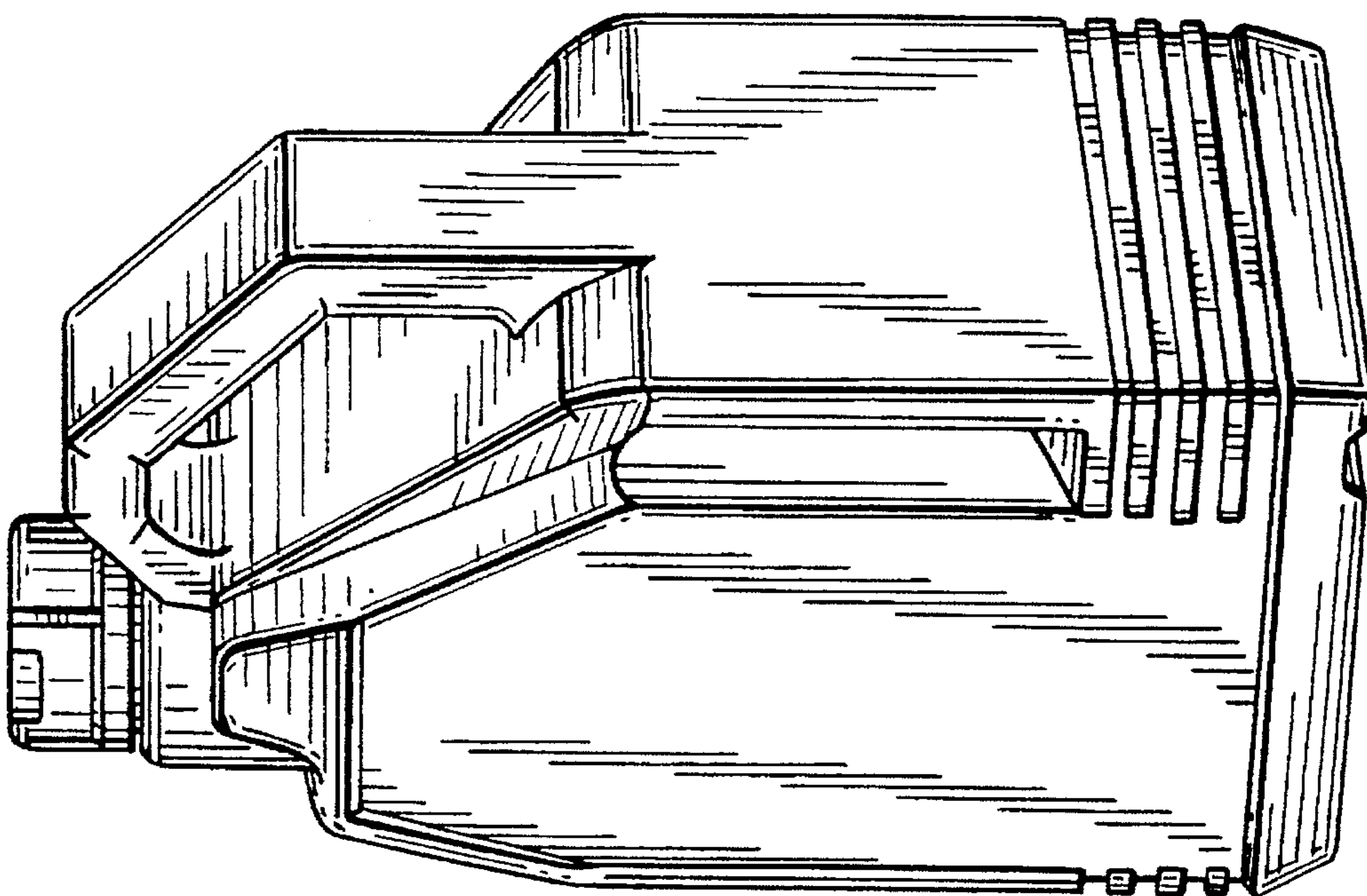

FIG. 3

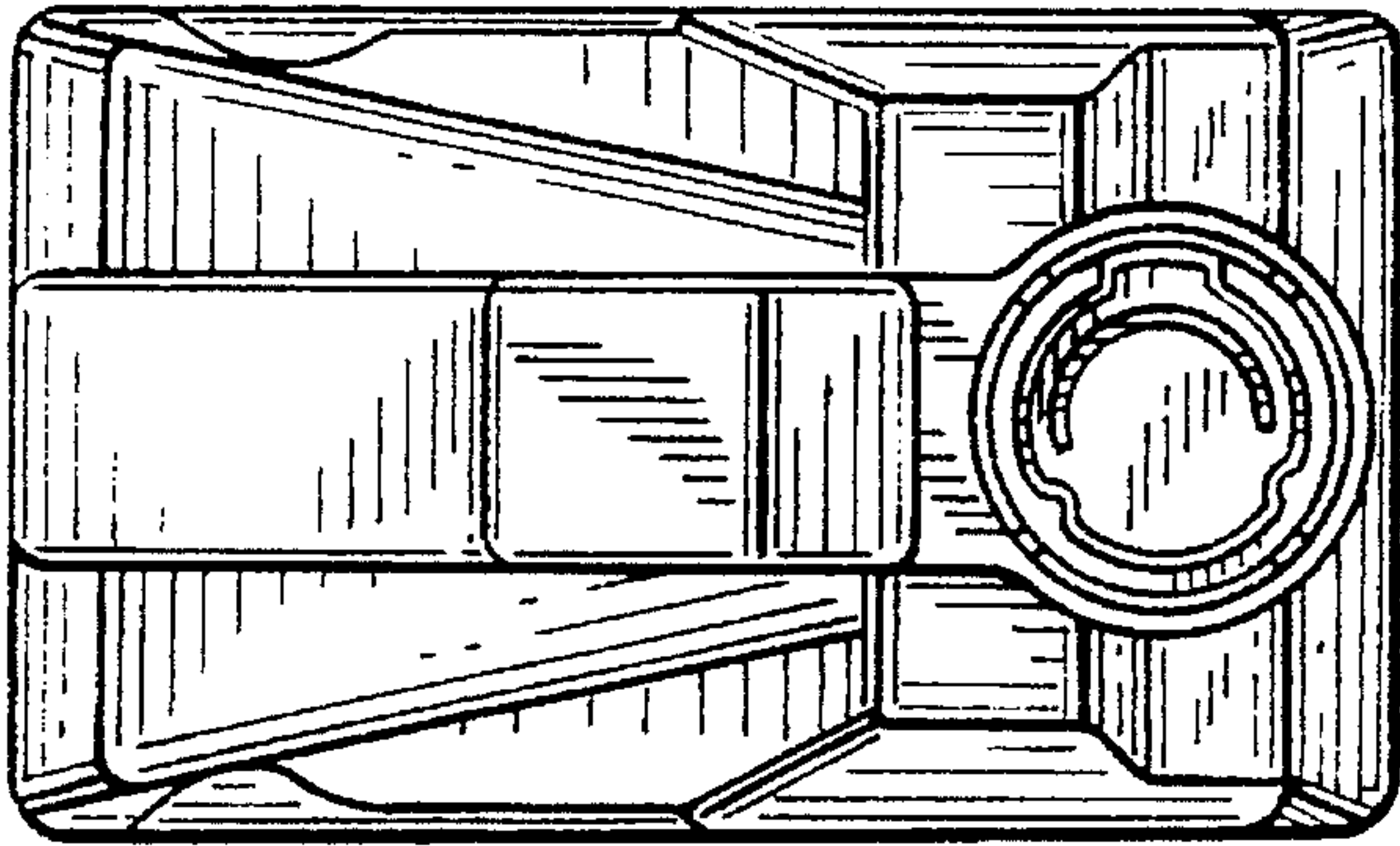

FIG. 4

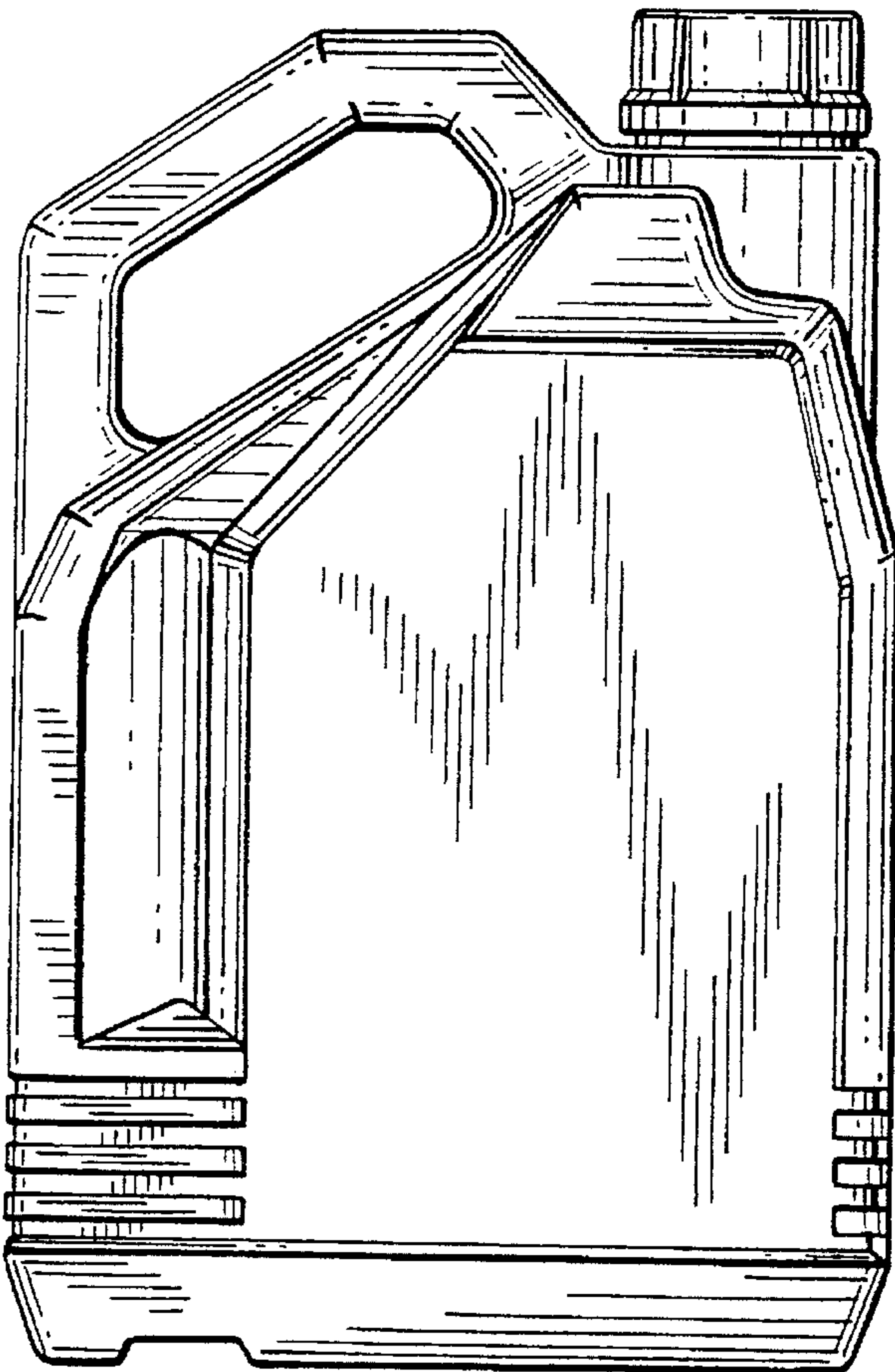

FIG. 5

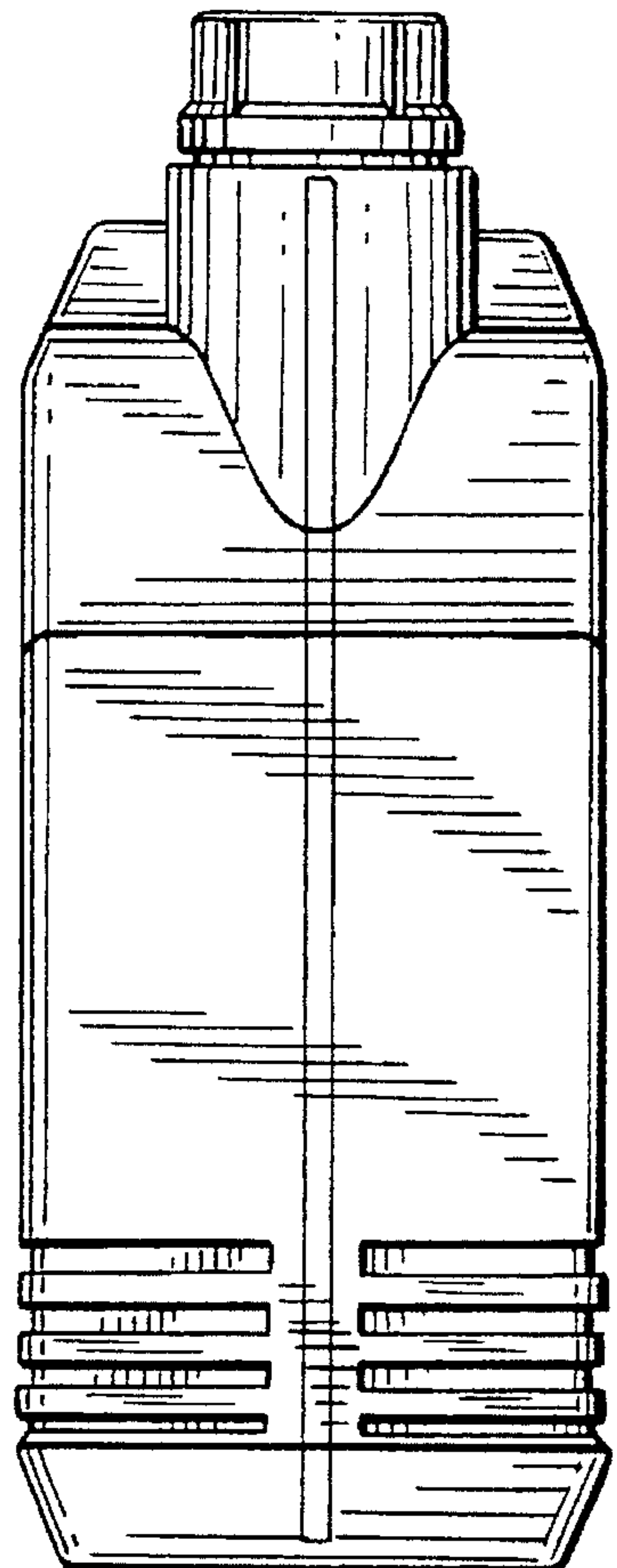

FIG. 6

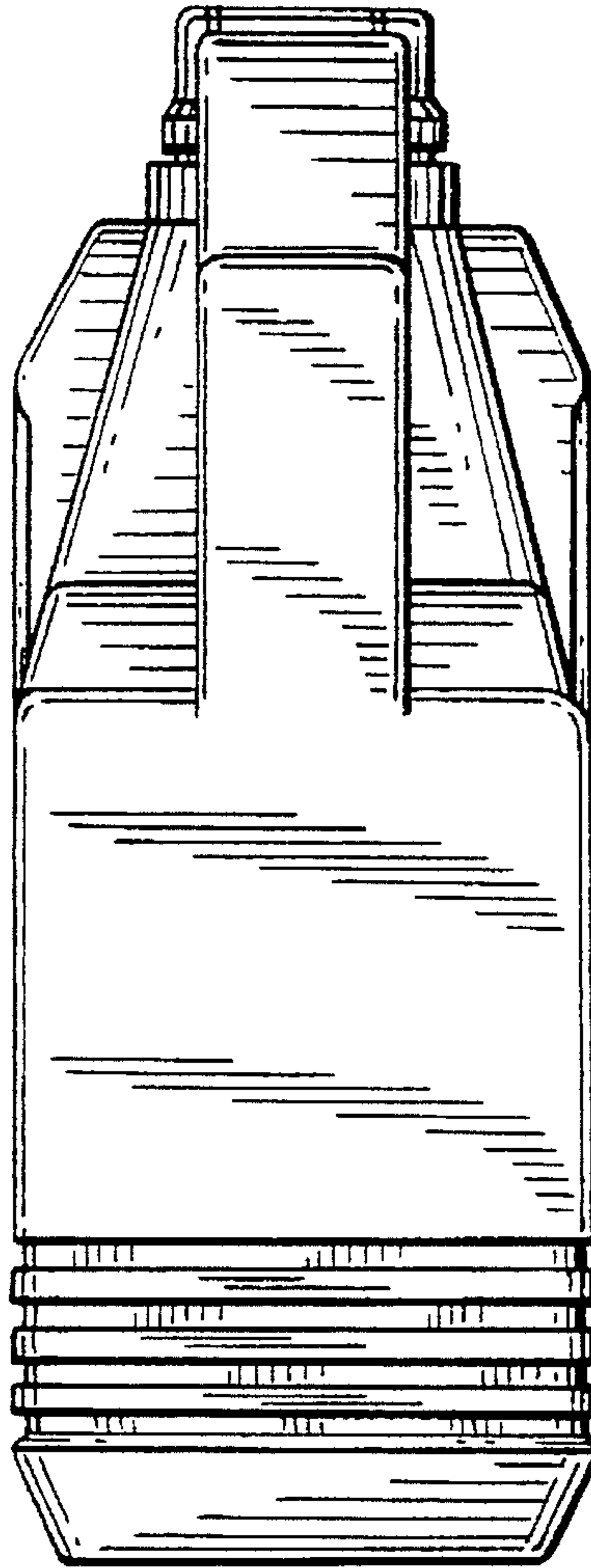

FIG. 7

