



US00D377527S

United States Patent [19]

[11] Patent Number: Des. 377,527

Michelson

[45] Date of Patent: **Jan. 21, 1997

[54] ARTIFICIAL SPINAL INFUSION IMPLANT

[75] Inventor: Gary K. Michelson, Venice, Calif.

[73] Assignee: Sofamor Danek Group, Inc.,
Memphis, Tenn.

[**] Term: 14 Years

[21] Appl. No.: 23,921

[22] Filed: Jun. 3, 1994

[52] U.S. Cl. D24/155

[58] Field of Search D24/155; 623/17;
606/61, 60, 73, 72

[56] References Cited

U.S. PATENT DOCUMENTS

5,192,327	3/1993	Brantigan	623/17
5,306,309	4/1994	Wagner et al.	606/61 X
5,397,364	3/1995	Kozak et al.	606/61 X
5,425,772	6/1995	Brantigan	623/17
5,443,514	8/1995	Steffee	623/17
5,458,638	10/1995	Kuslich et al.	606/61 X

Primary Examiner—Stella Reid

Attorney, Agent, or Firm—Woodard, Emhardt, Naughton,
Moriarty & McNett

[57] CLAIM

The ornamental design for the an artificial spinal infusion implant, as shown and described.

DESCRIPTION

FIG. 1 is a perspective view of the an artificial spinal infusion implant showing my new design;

FIG. 2 is a top plan view of the design of FIG. 1, with the bottom plan view being a mirror image thereof;

FIG. 3 is a left side elevational view of the design of FIG. 1;

FIG. 4 is a right side elevational view of the design of FIG. 1;

FIG. 5 is a rear end view of the design of FIG. 3;

FIG. 6 is a front end view of the design of FIG. 1;

FIG. 7 is an enlarged fragmentary view along line 7 of the design of FIG. 2;

FIG. 8 is a top plan view of a first alternative embodiment of the design of FIG. 1, the bottom plan view being a mirror image thereof;

FIG. 9 is a left side elevational view of the design of FIG. 8;

FIG. 10 is a right side elevational view of the design of FIG. 8;

FIG. 11 is a rear end view of the design of FIG. 8;

FIG. 12 is a front end view of the design of FIG. 8;

FIG. 13 is an enlarged fragmentary view along line 13 of the design of FIG. 8;

FIG. 14 is a top plan view of a second alternative embodiment of the design of FIG. 1, the bottom plan view being a mirror image thereof;

FIG. 15 is a left side elevational view of the design of FIG. 14;

FIG. 16 is a right side elevational view of design of FIG. 14;

FIG. 17 is a rear end view of the design of FIG. 14;

FIG. 18 is a front end view of the design of FIG. 14;

FIG. 19 is an enlarged fragmentary view along line 19 of the design of FIG. 14;

FIG. 20 is a top plan view of a third alternative embodiment of the design of FIG. 1, the bottom plan view being a mirror image thereof;

FIG. 21 is a left side elevational view of the design of FIG. 20;

FIG. 22 is a right side elevational view of the design of FIG. 20;

FIG. 23 is a rear end view of the design of FIG. 20;

FIG. 24 is a front end view of the design of FIG. 20; and,

FIG. 25 is an enlarged fragmentary view along line 25 of the design of FIG. 20.

1 Claim, 5 Drawing Sheets

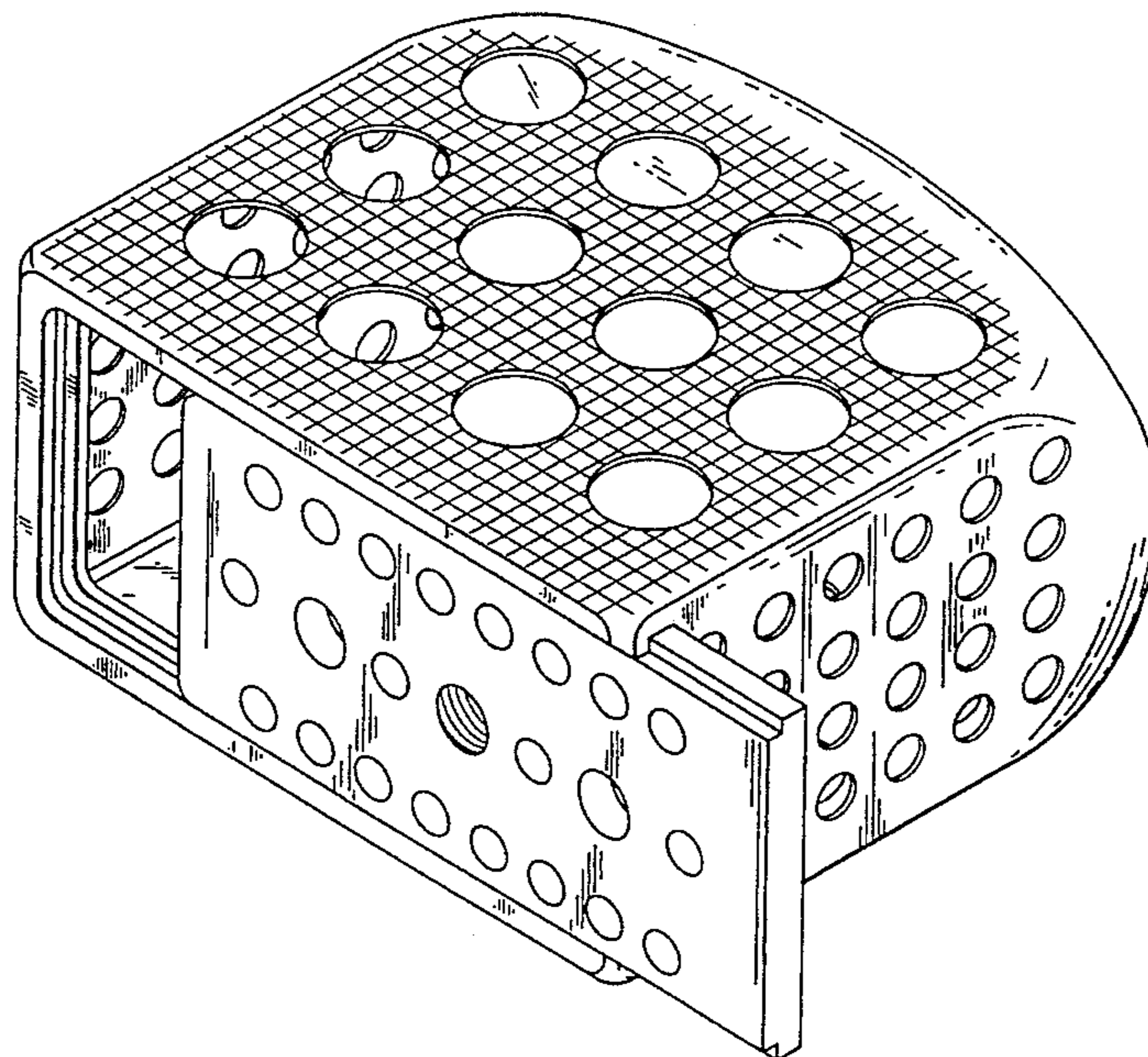

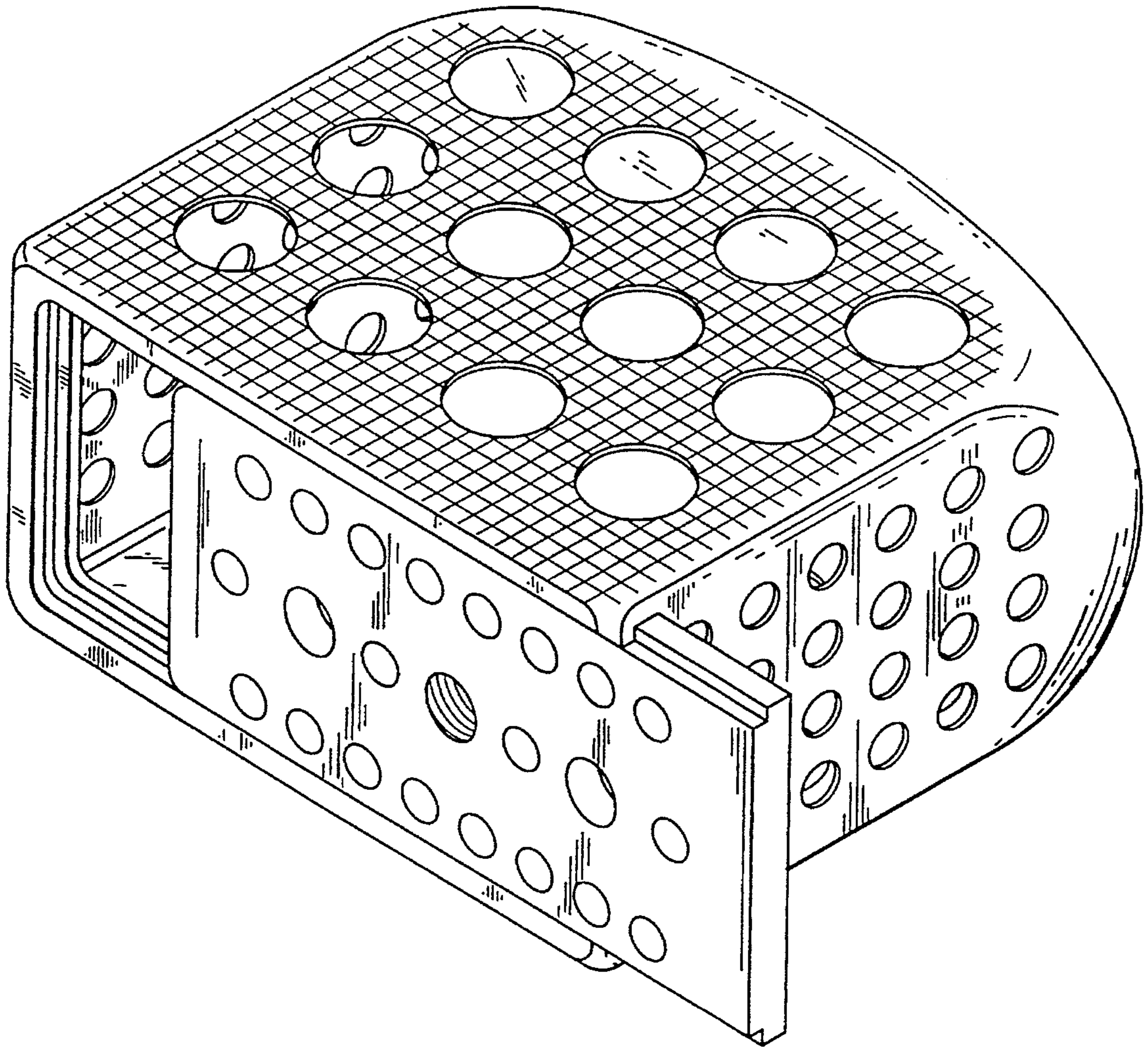

Fig. 1

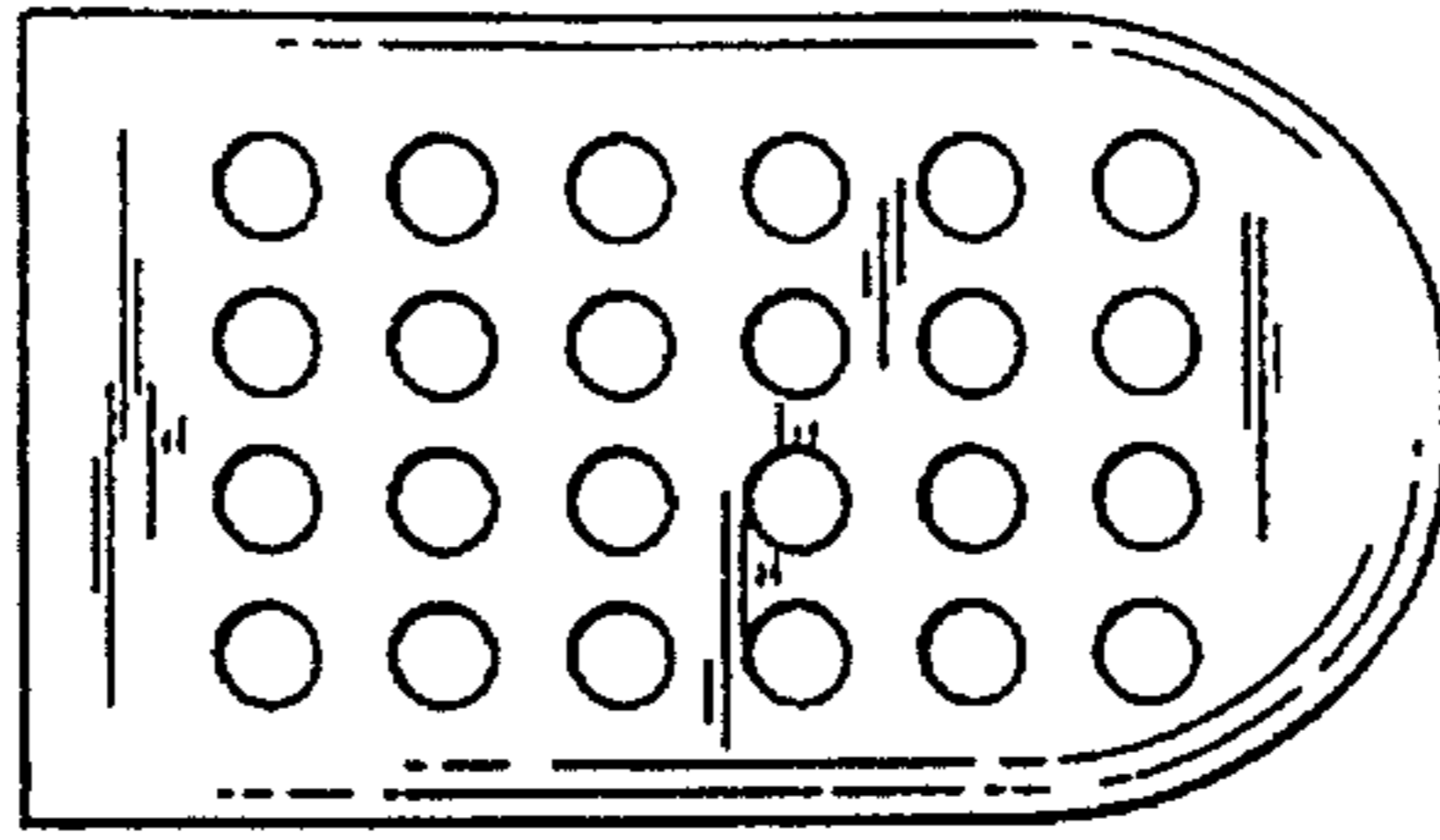

Fig. 3

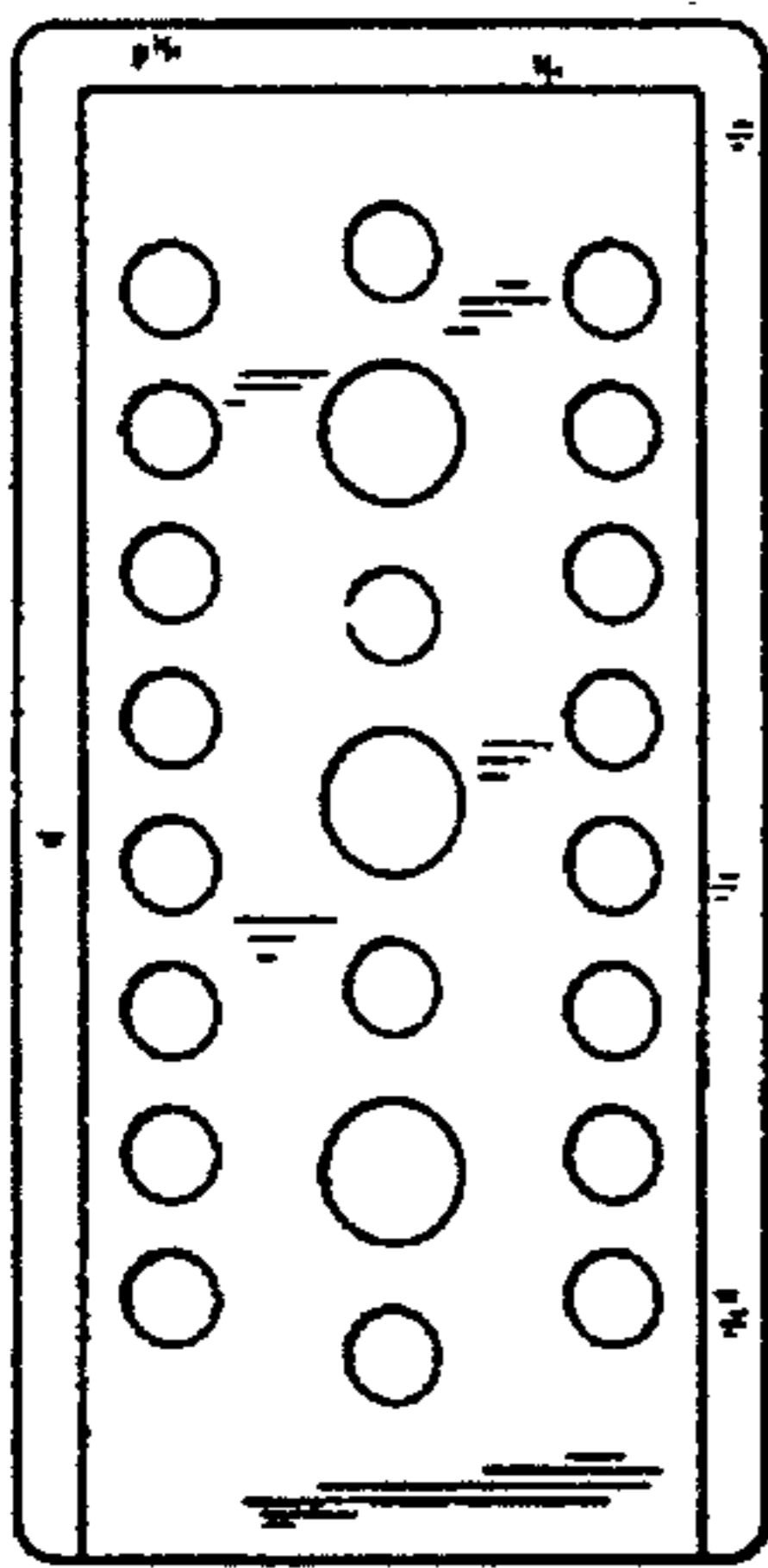

Fig. 5

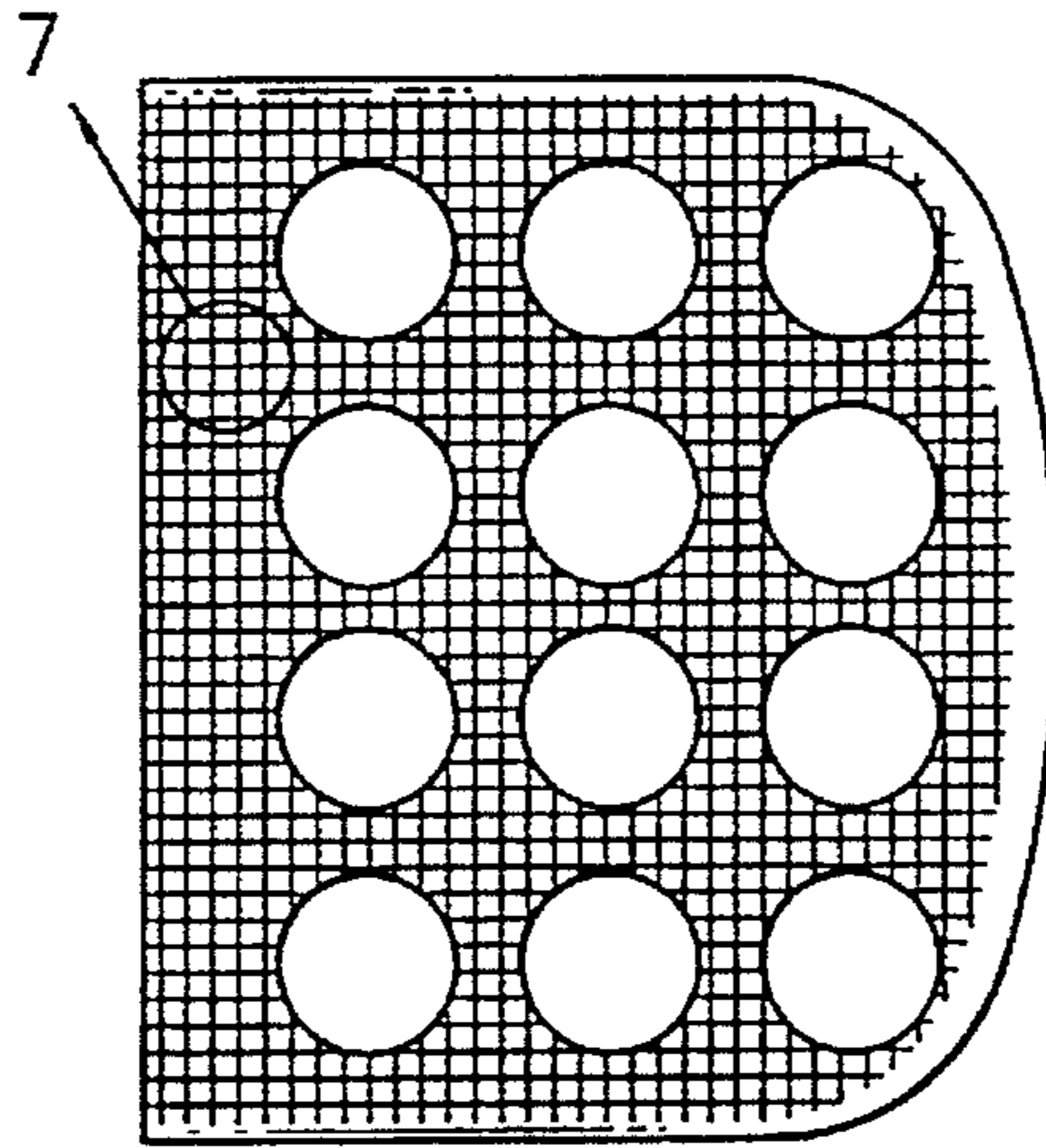

Fig. 2

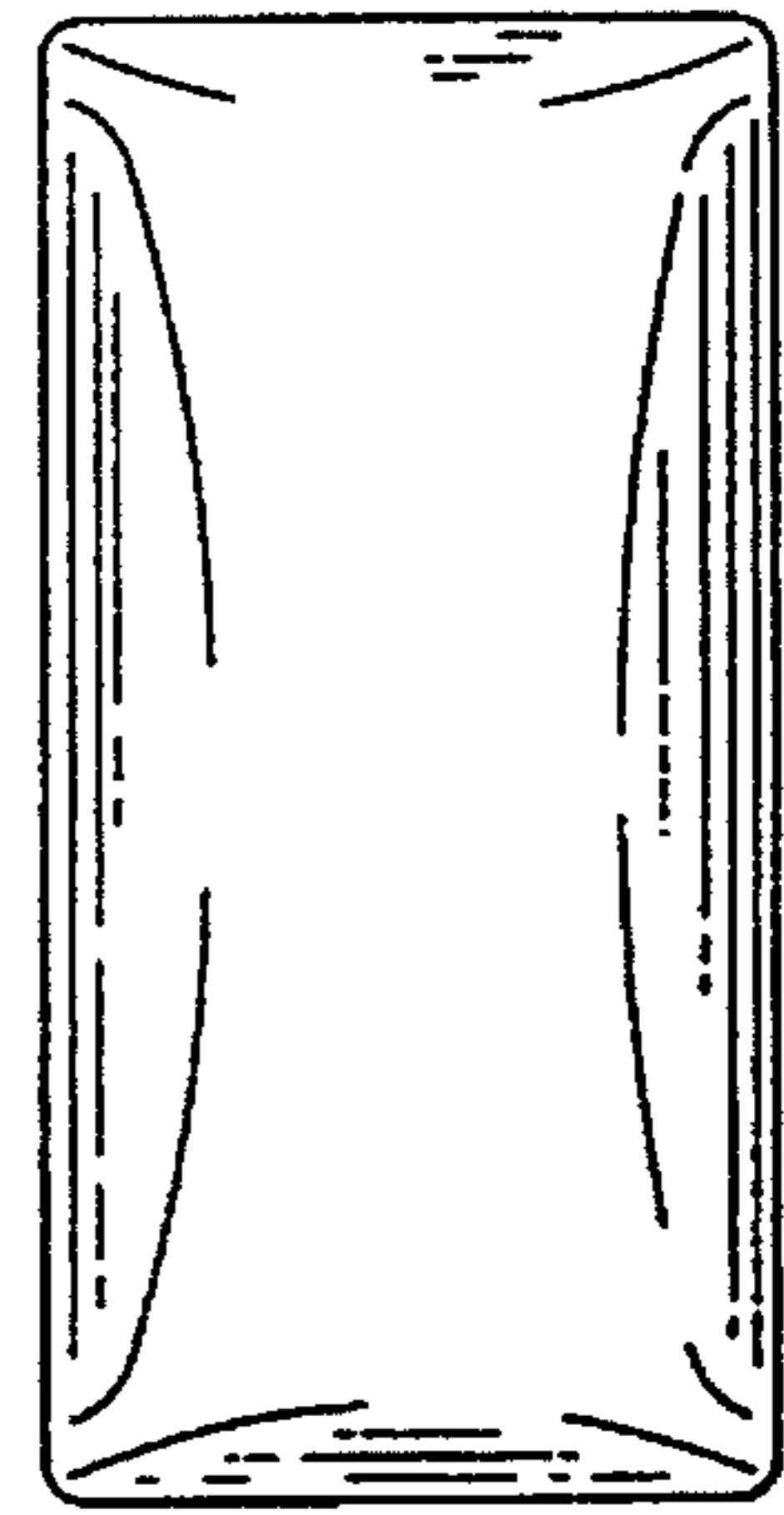

Fig. 6

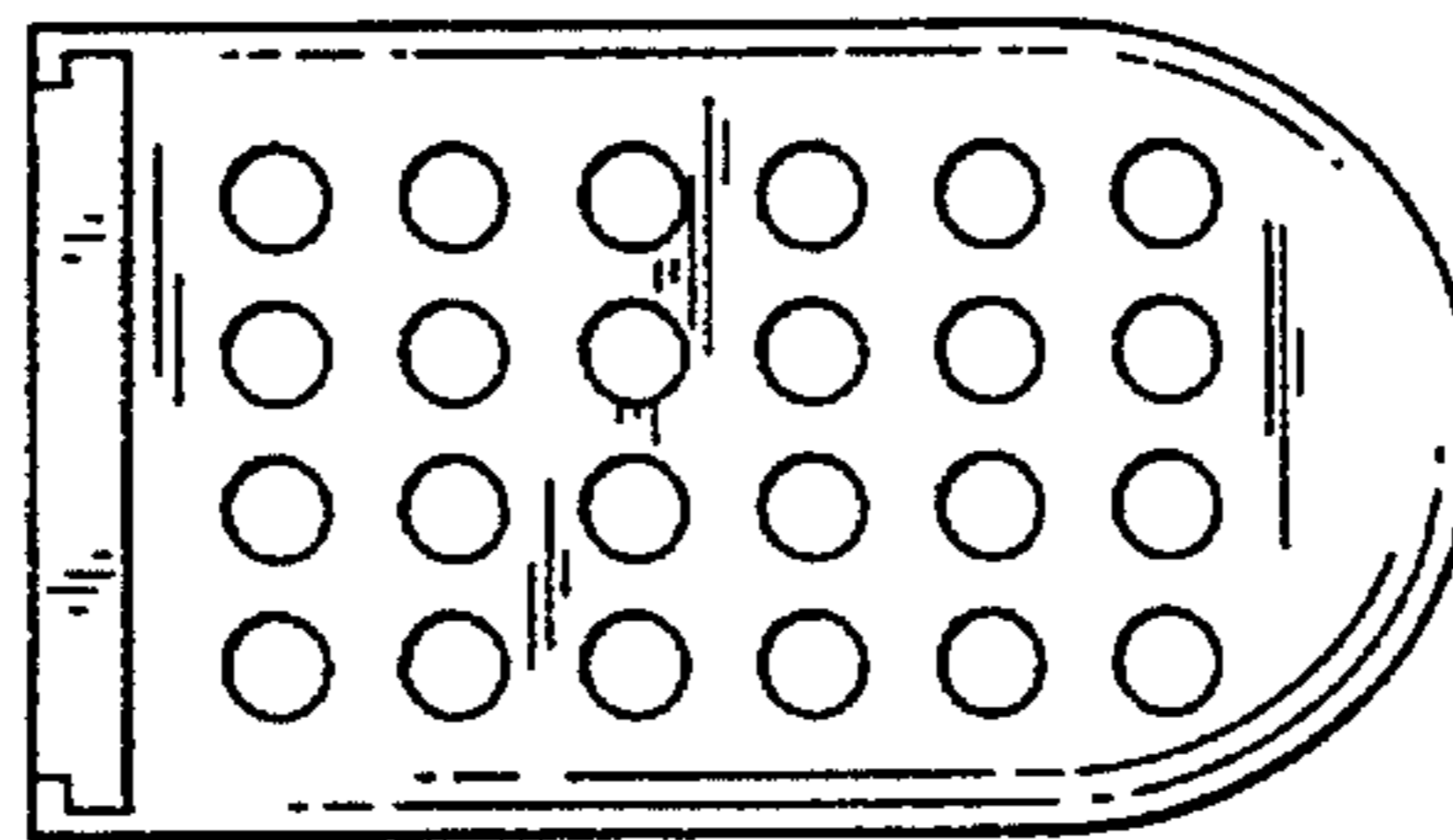

Fig. 4

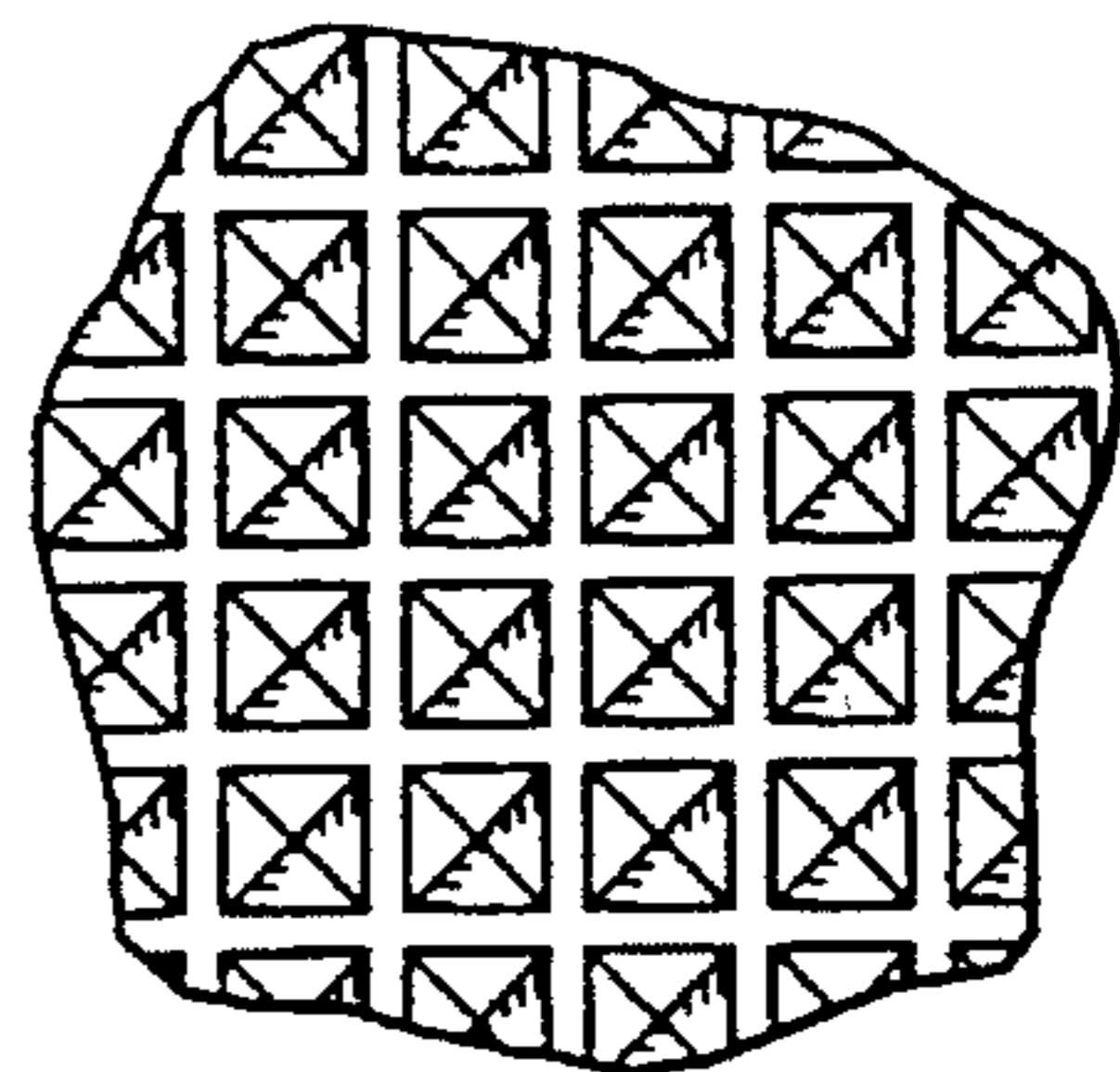

Fig. 7

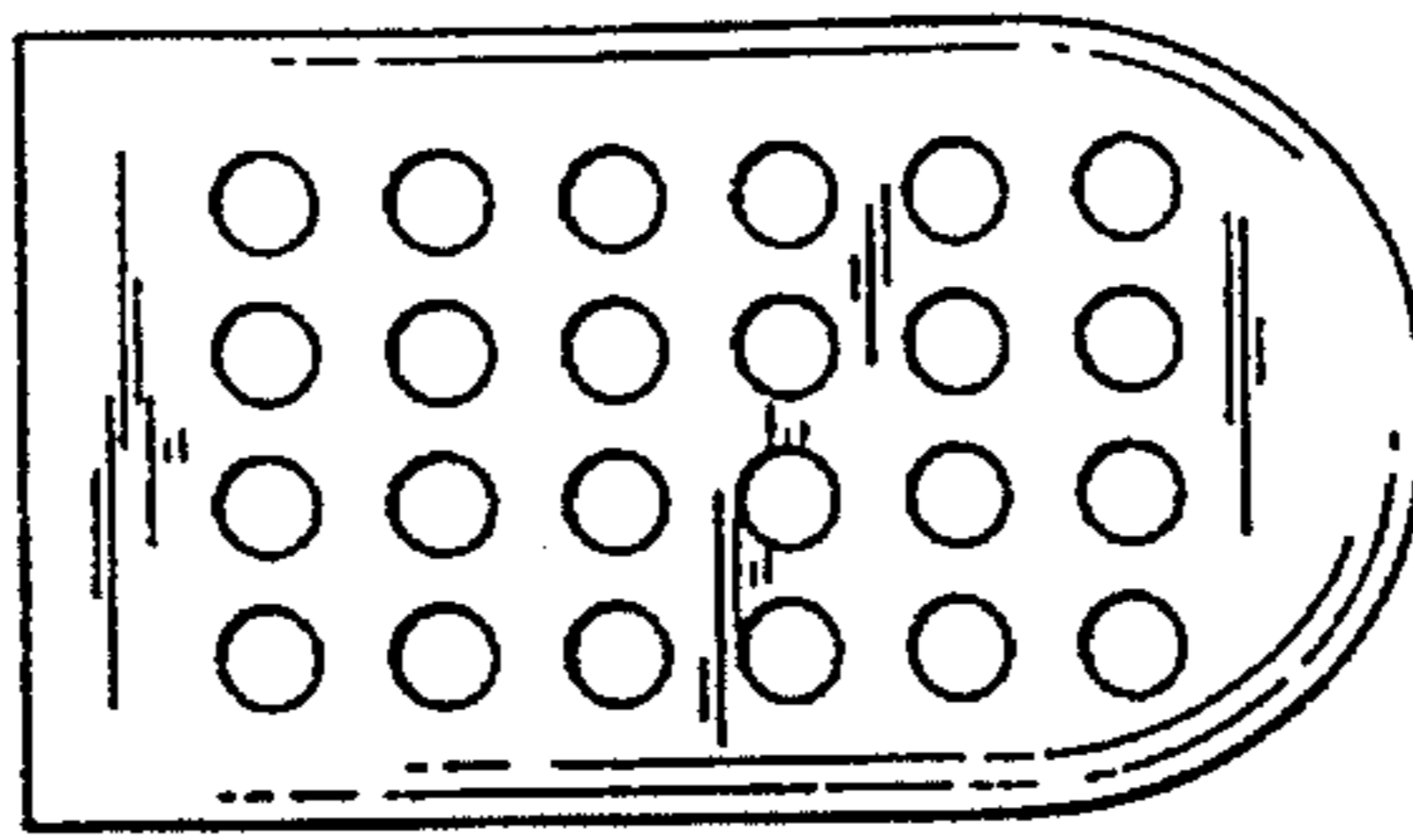

Fig. 9

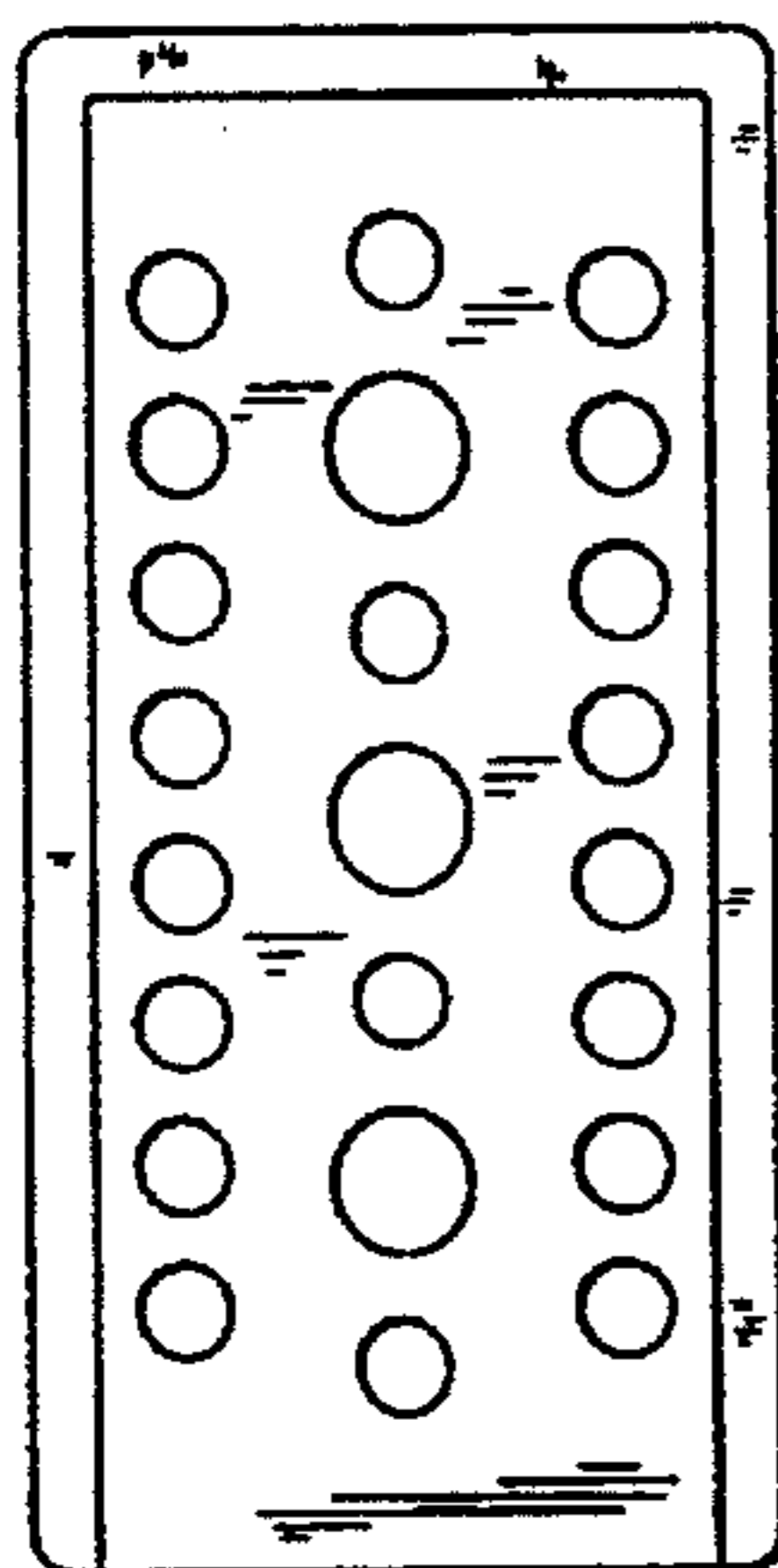

Fig. 11

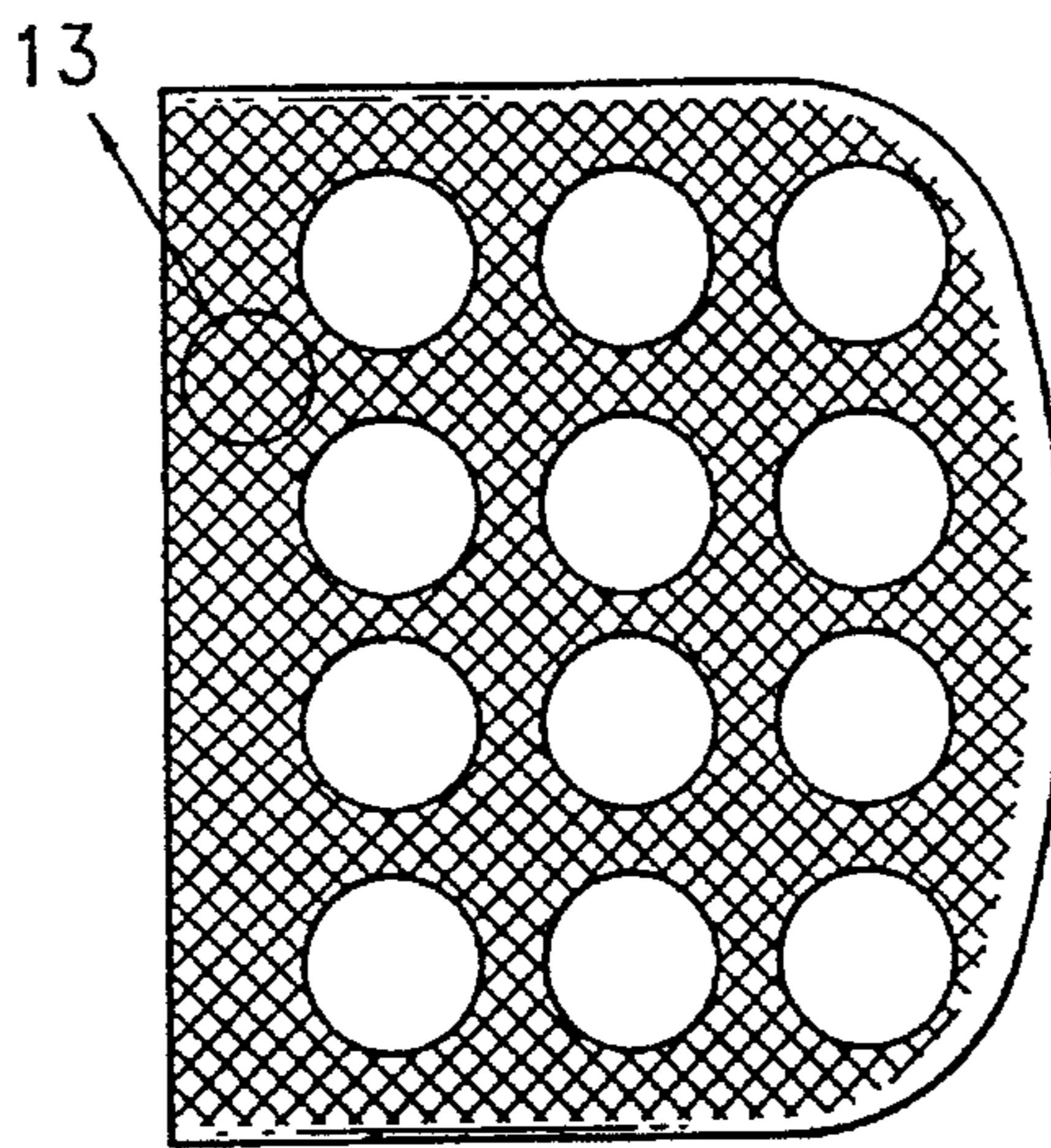

Fig. 8

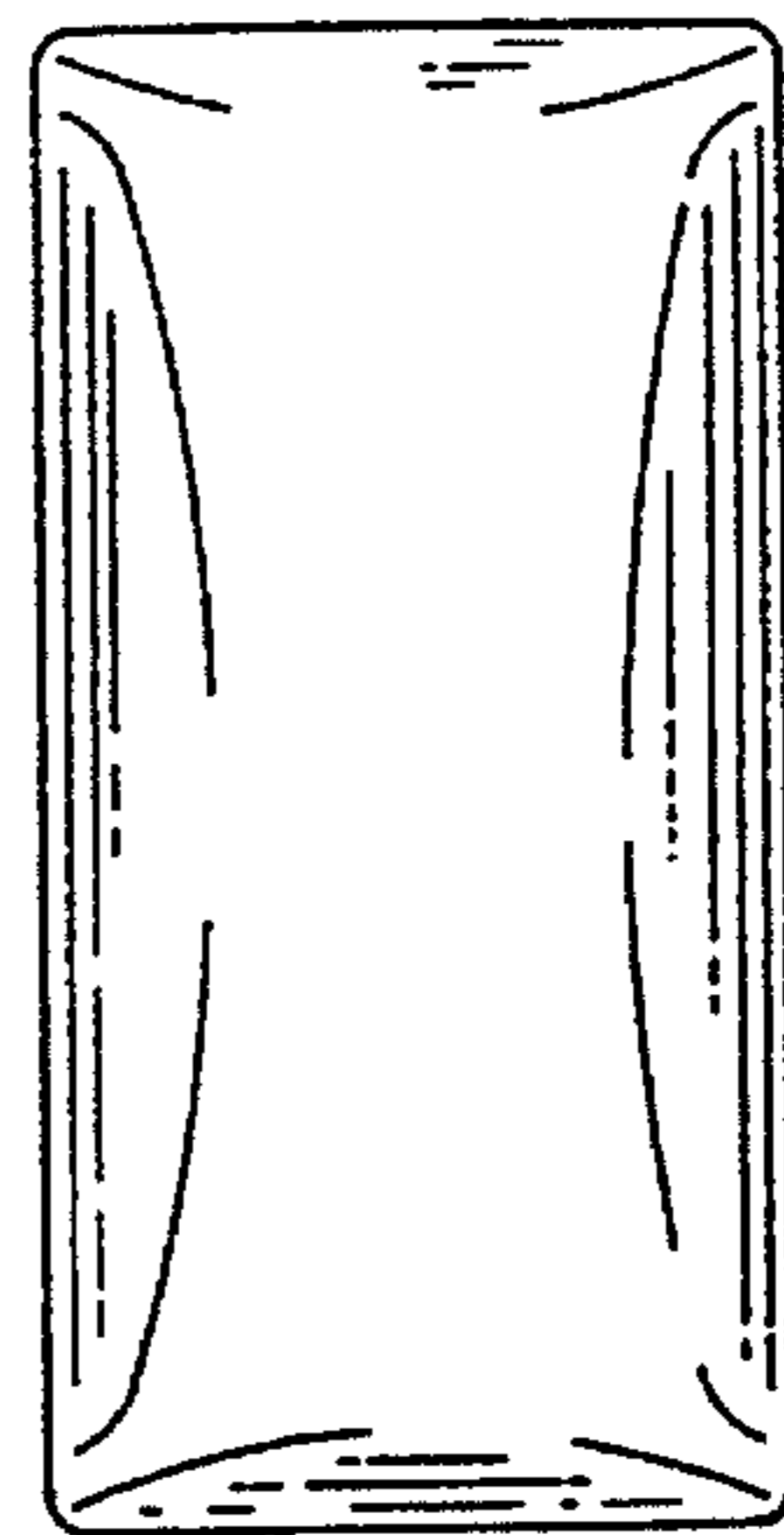

Fig. 12

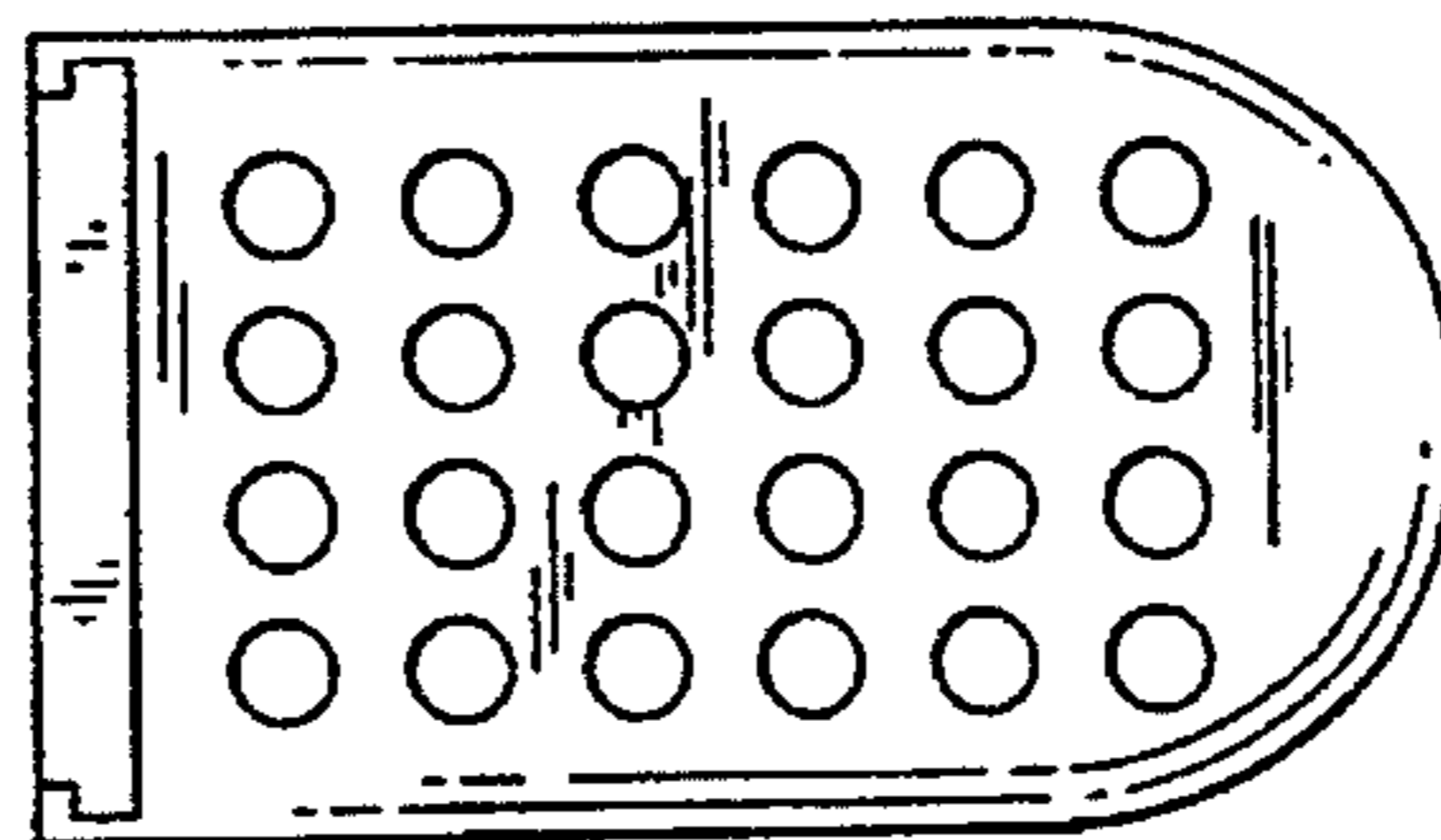

Fig. 10

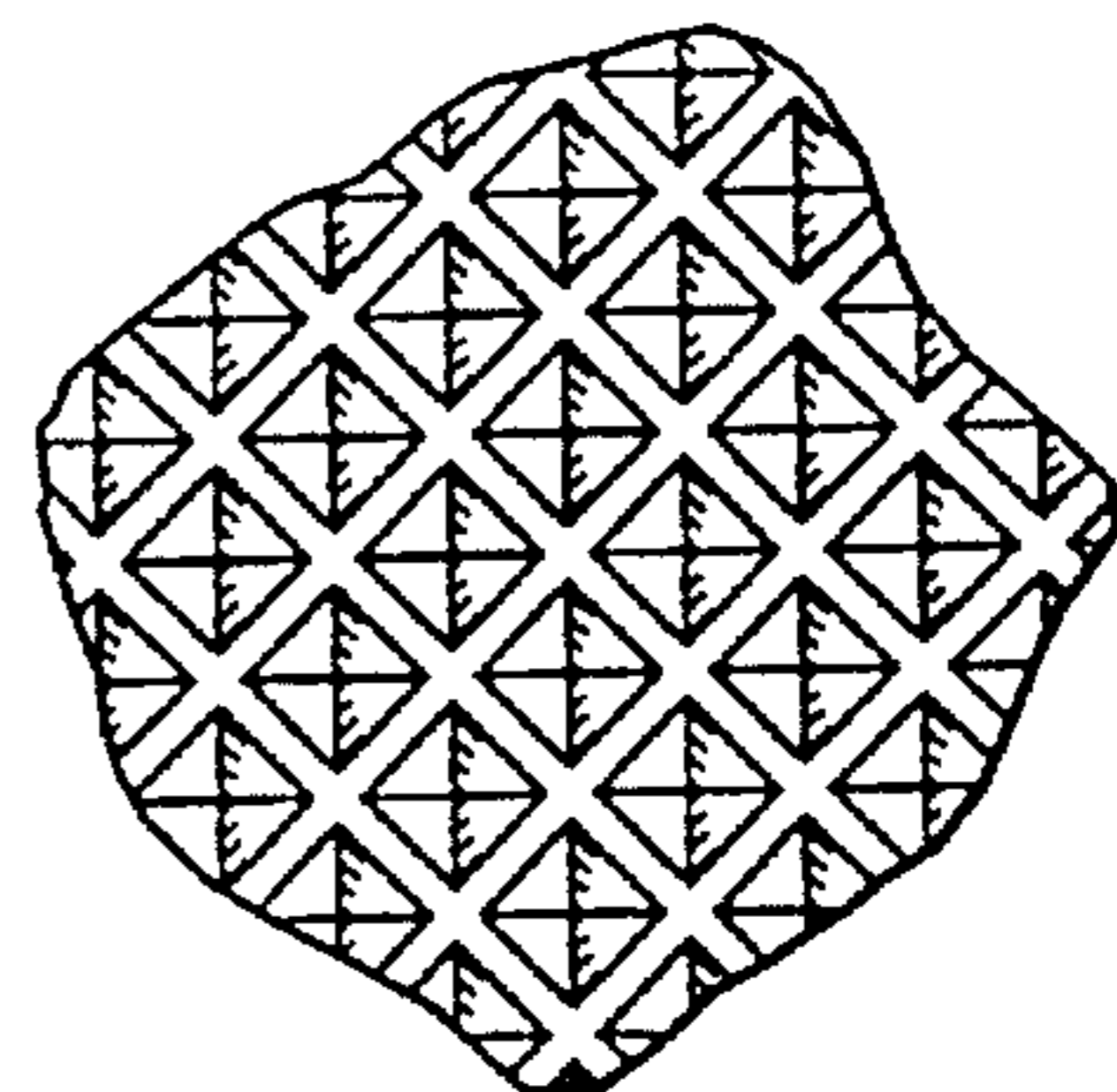

Fig. 13

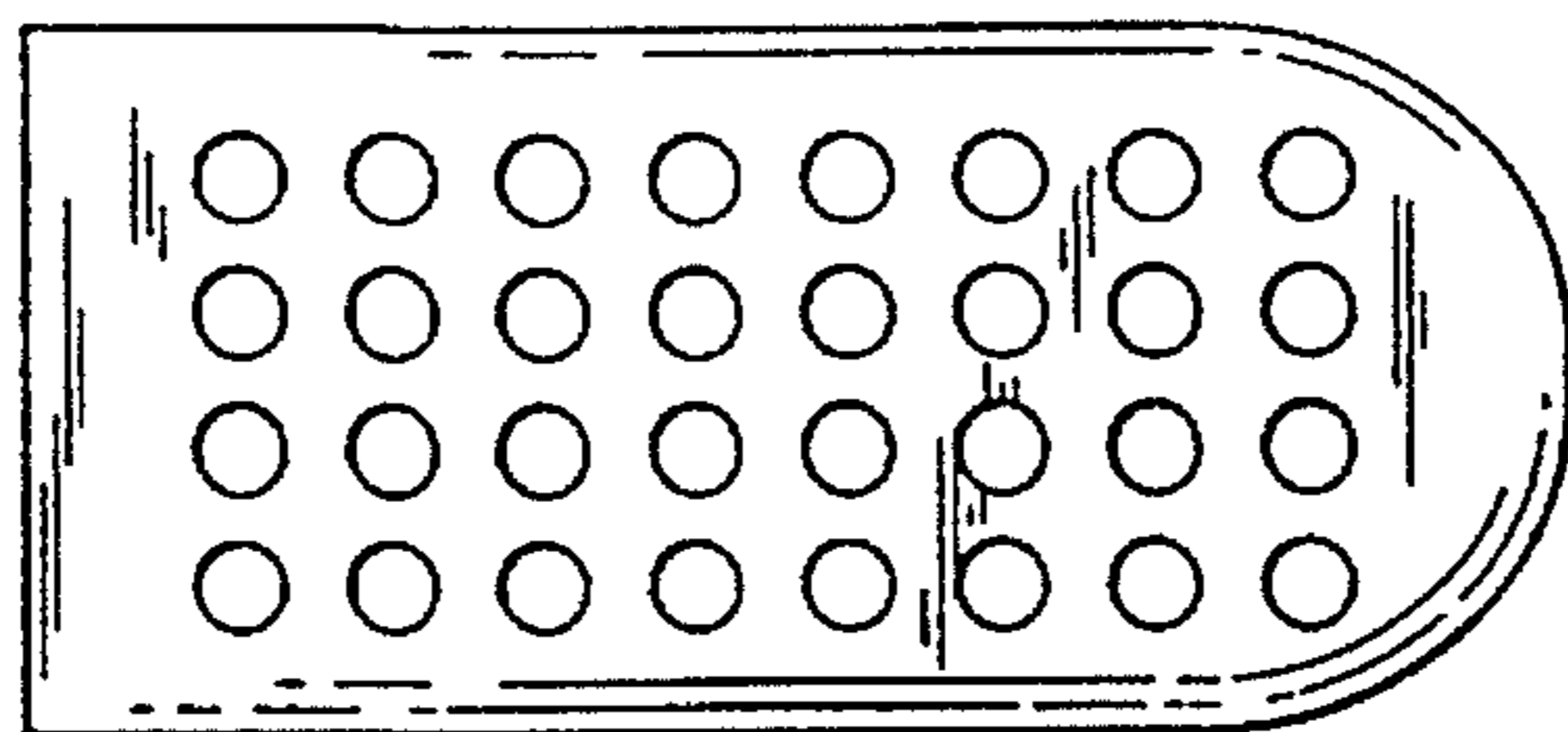

Fig. 15

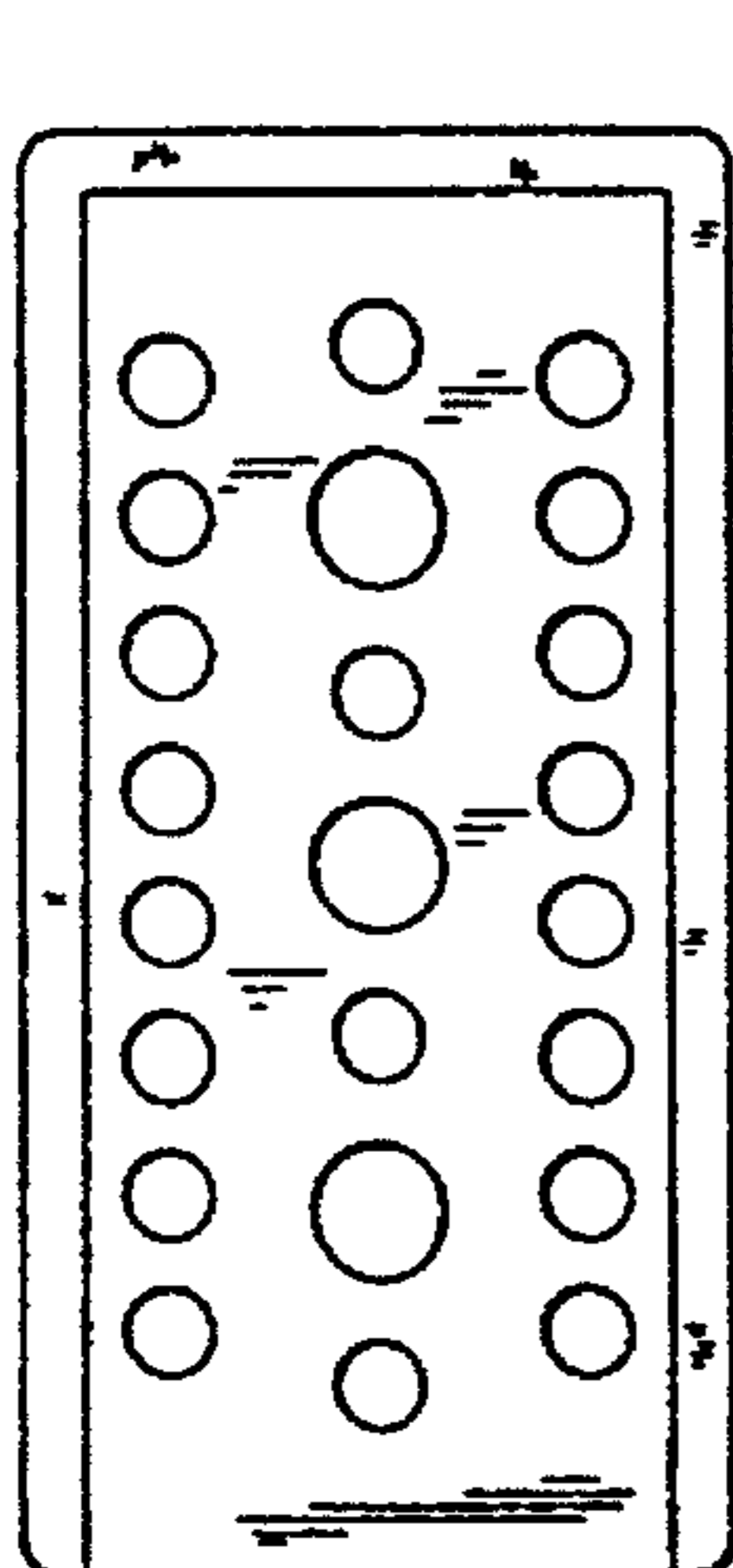

Fig. 17

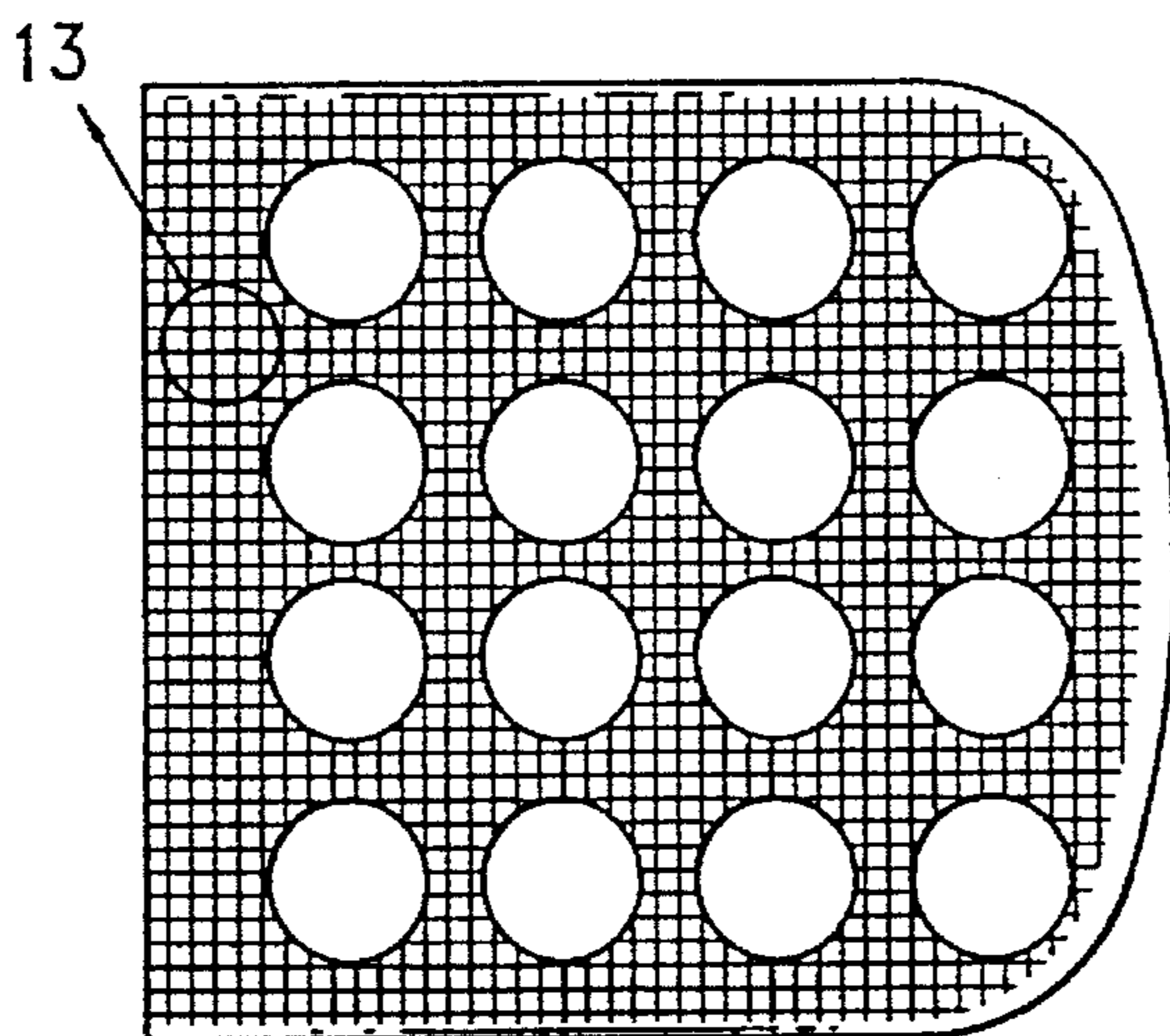

Fig. 14

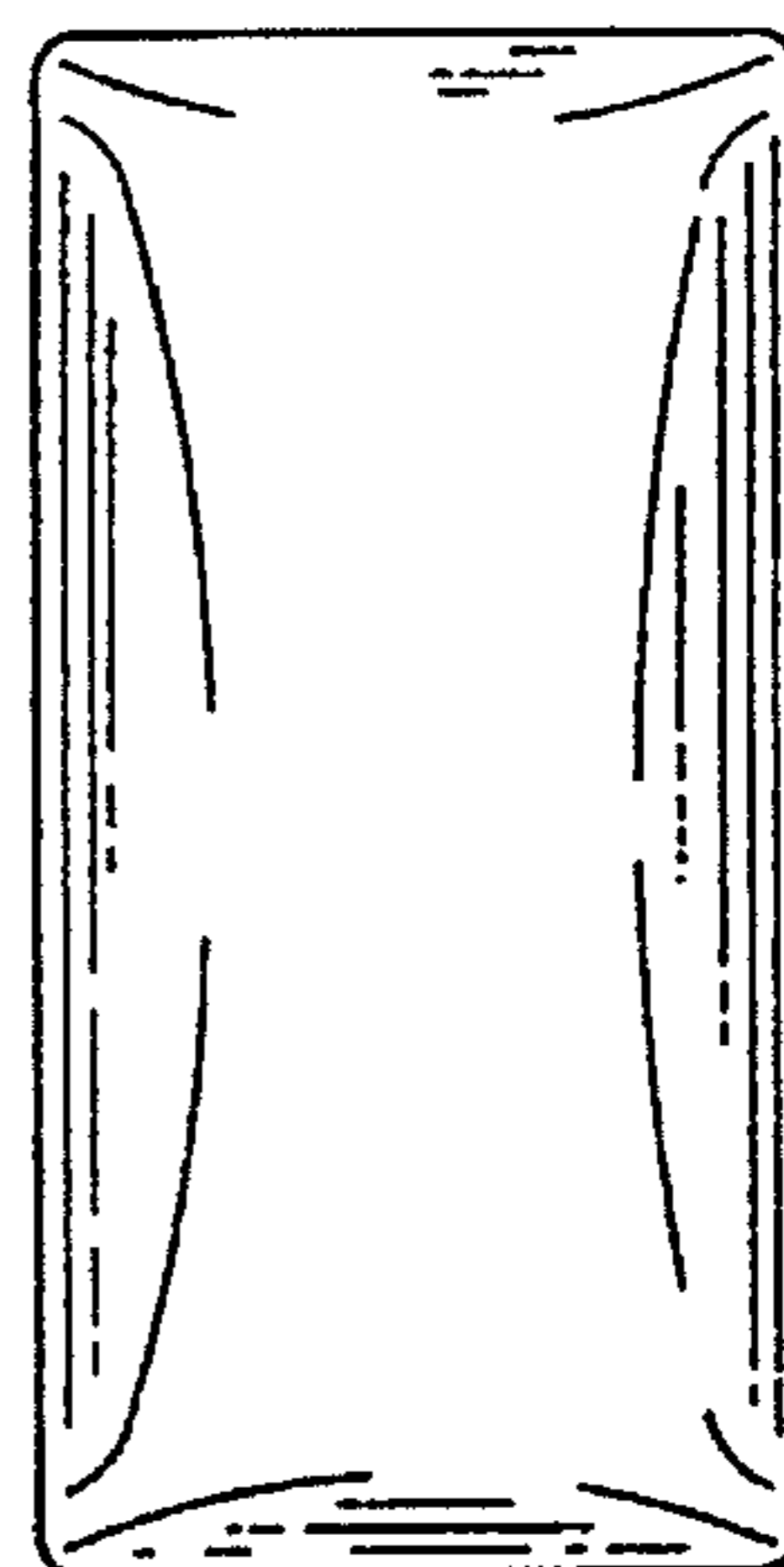

Fig. 18

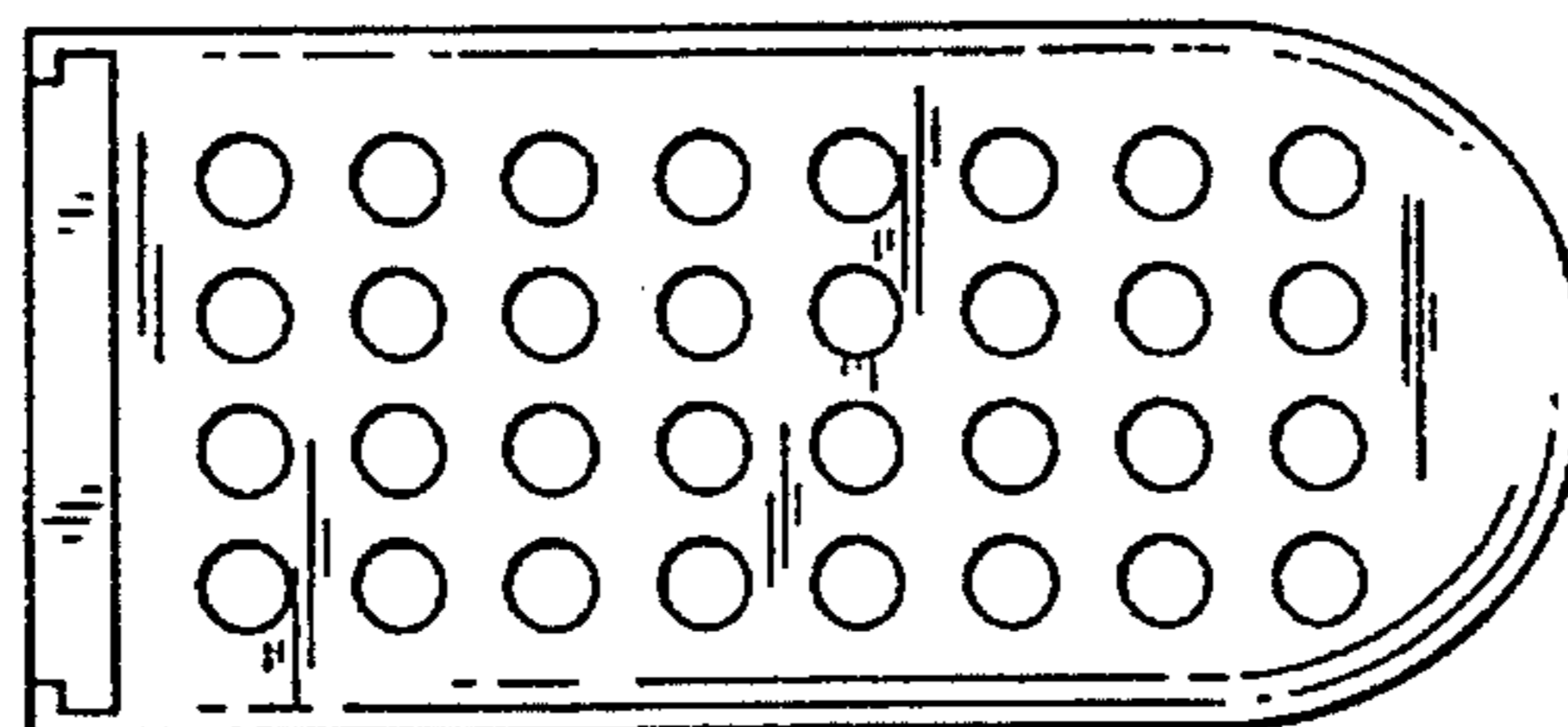

Fig. 16

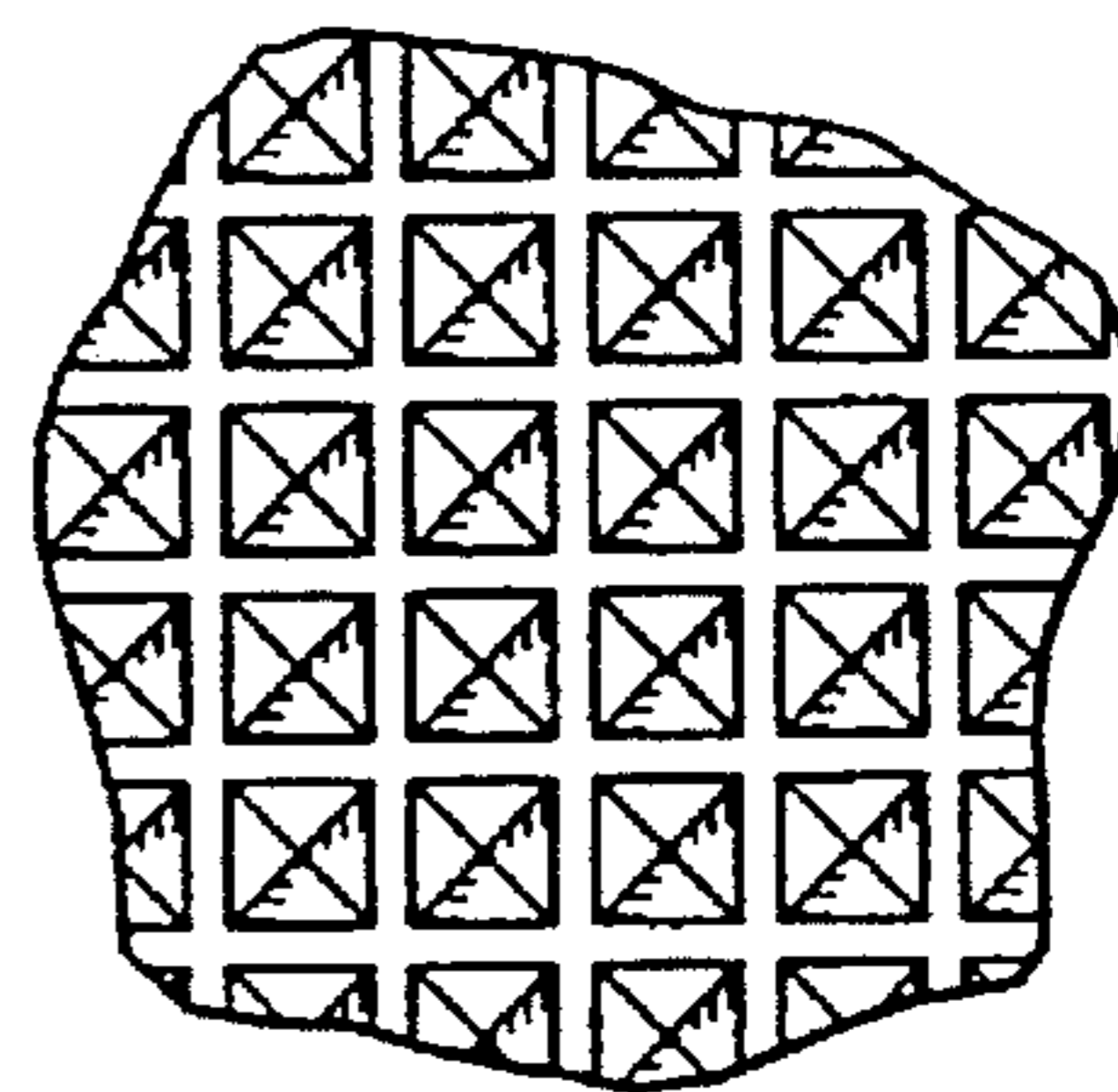

Fig. 19

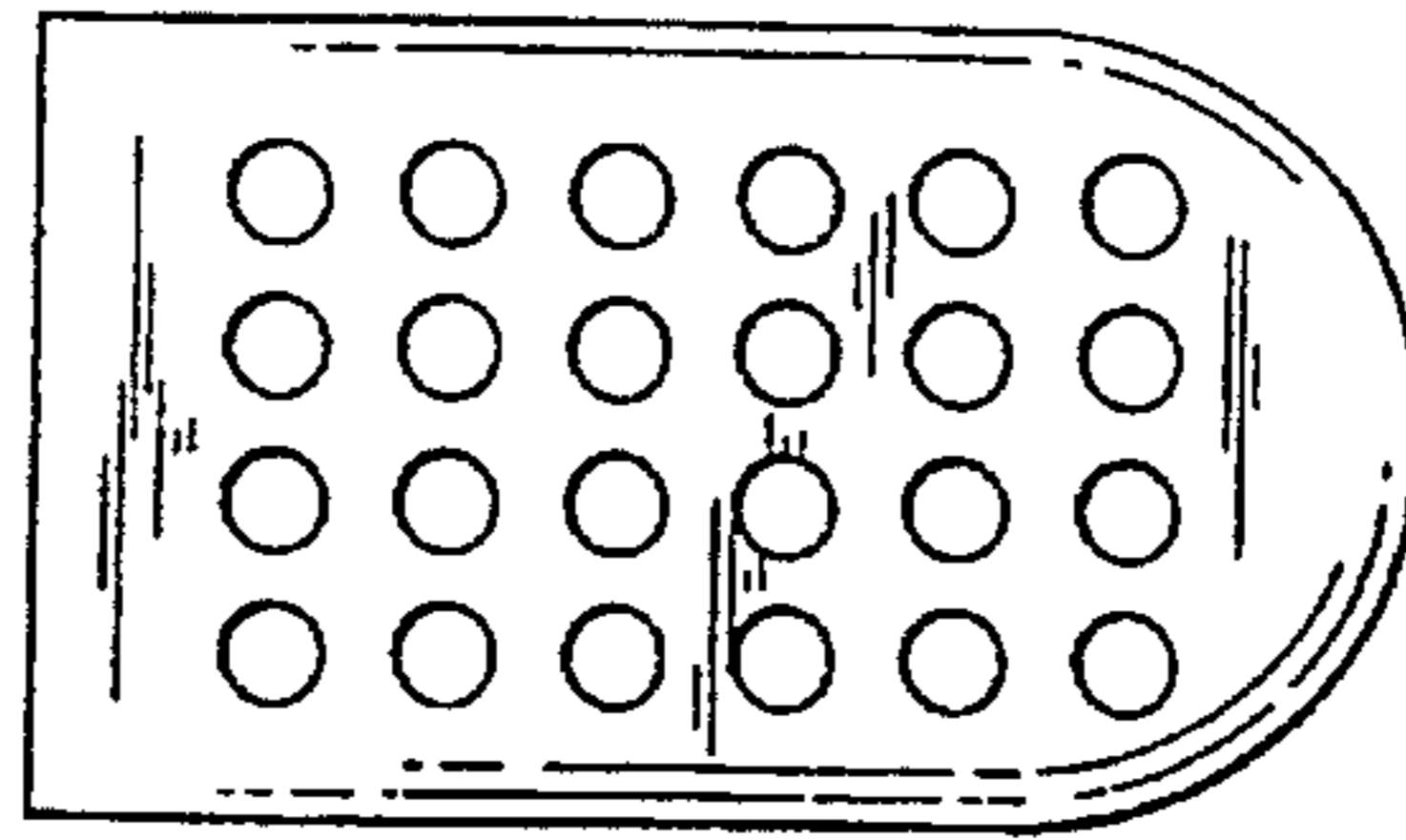

Fig. 21

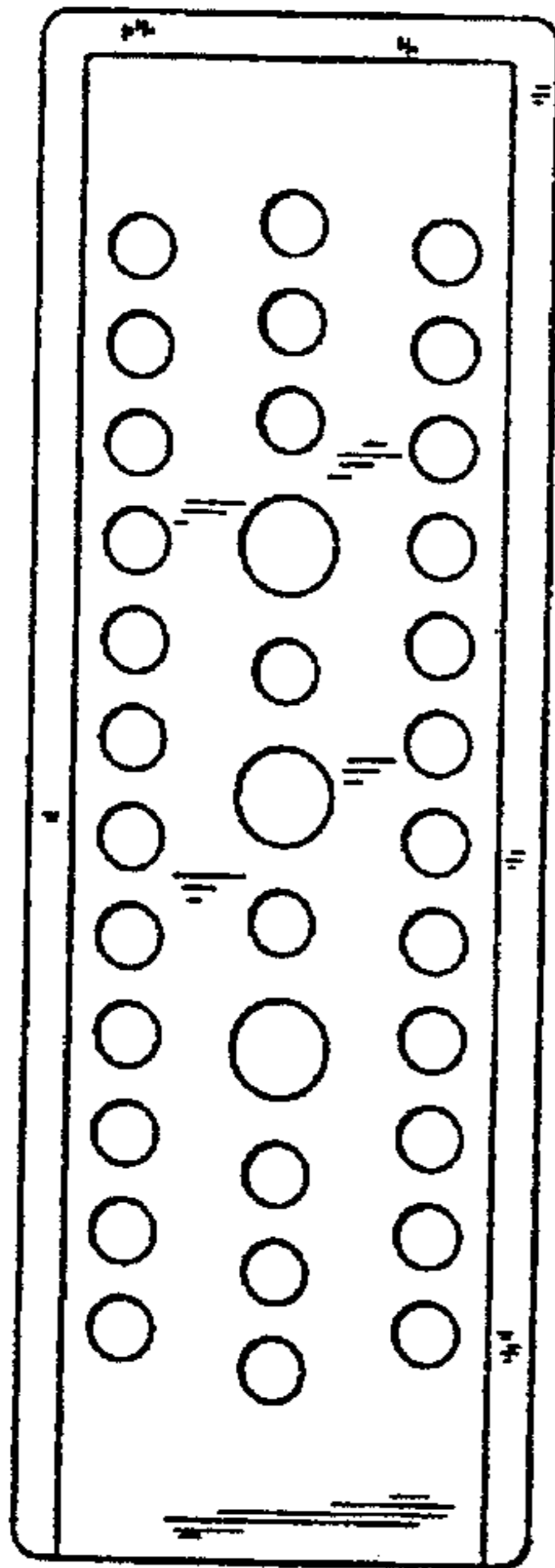

Fig. 23

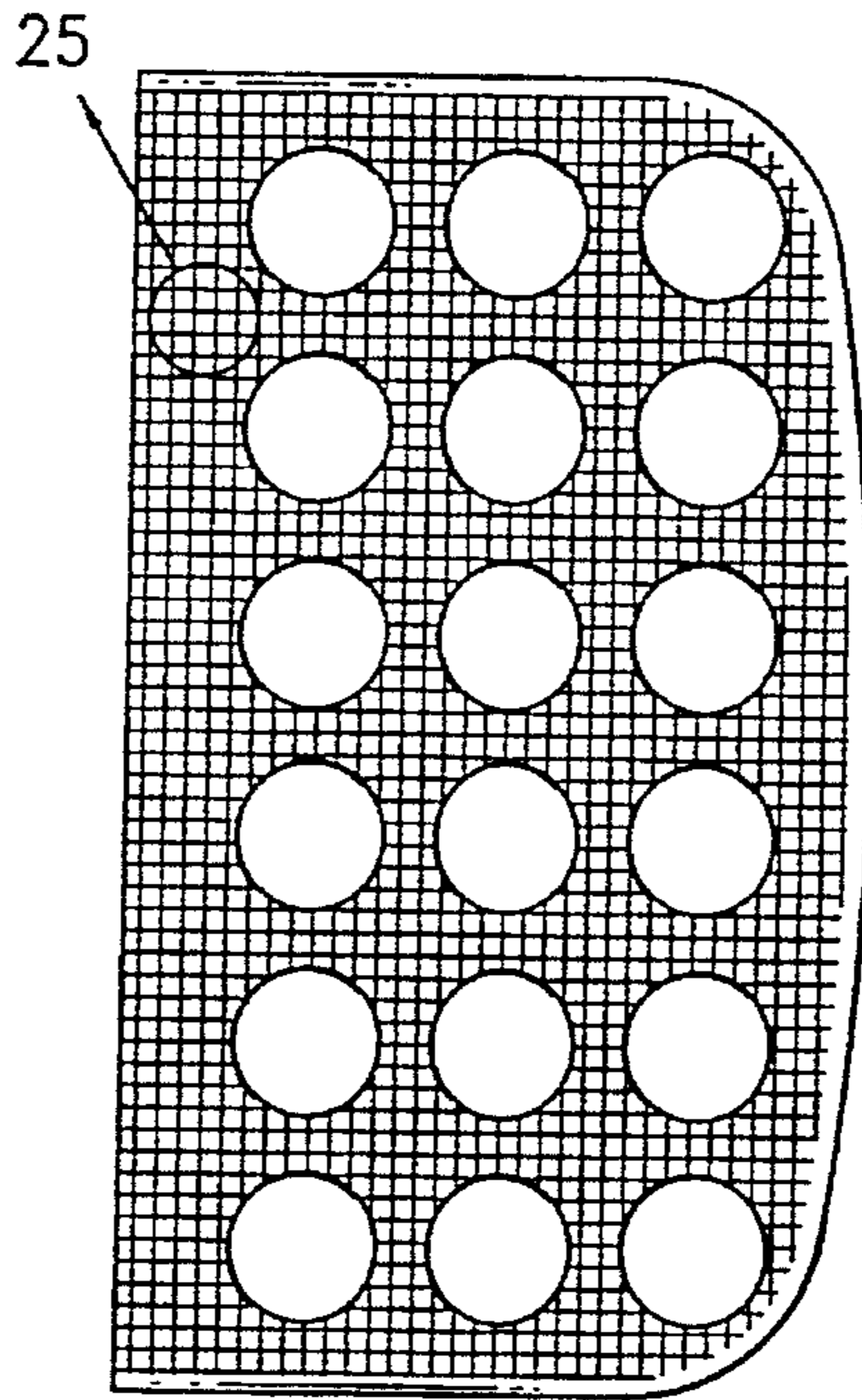

Fig. 20

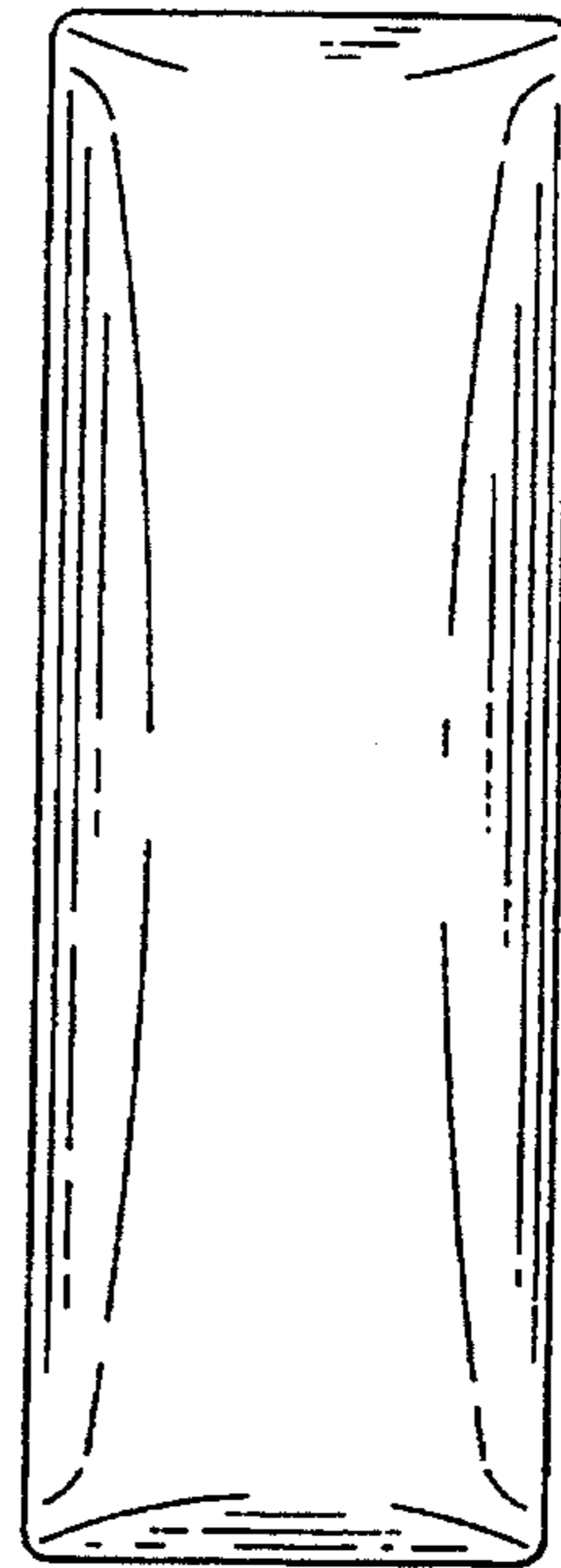

Fig. 24

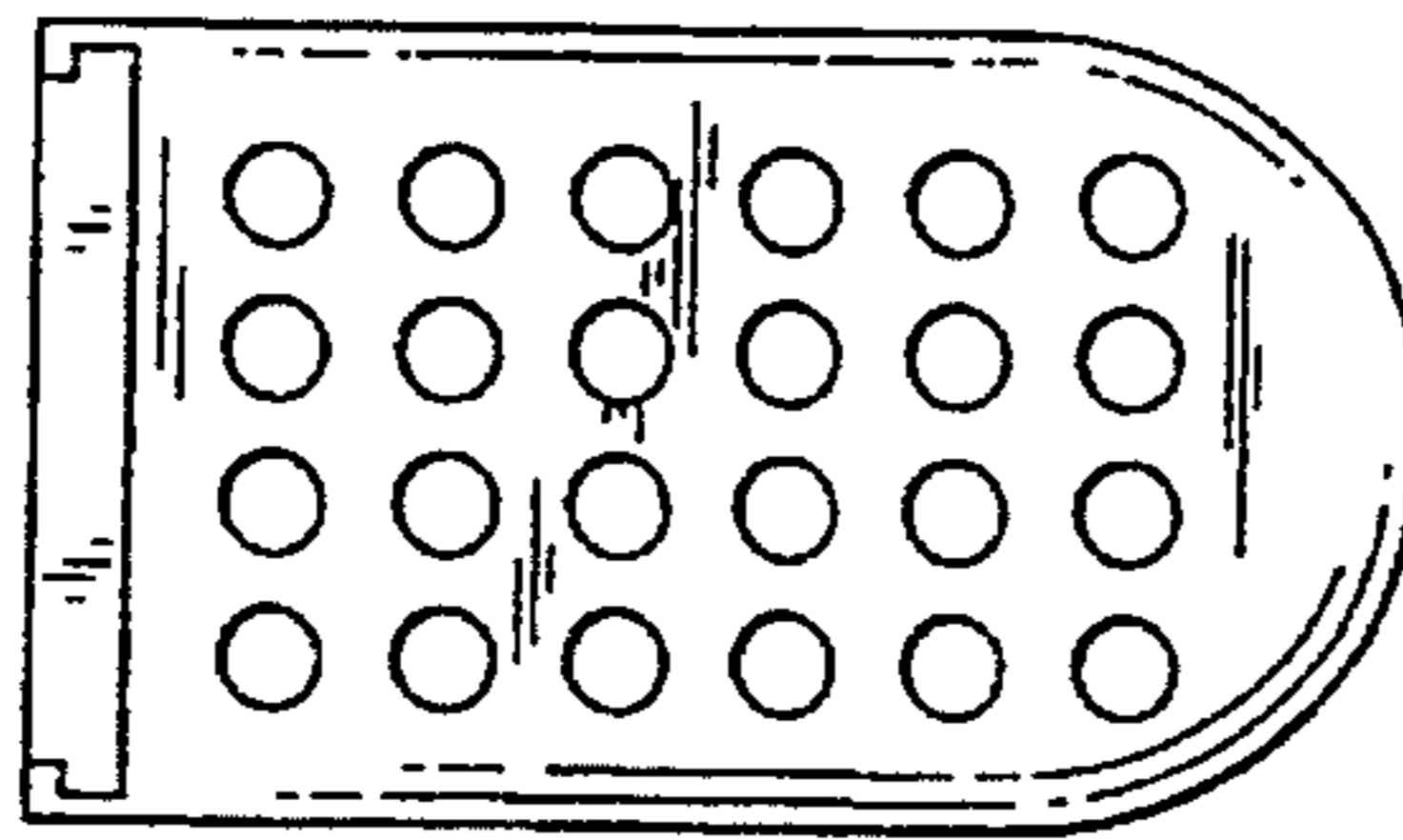

Fig. 22

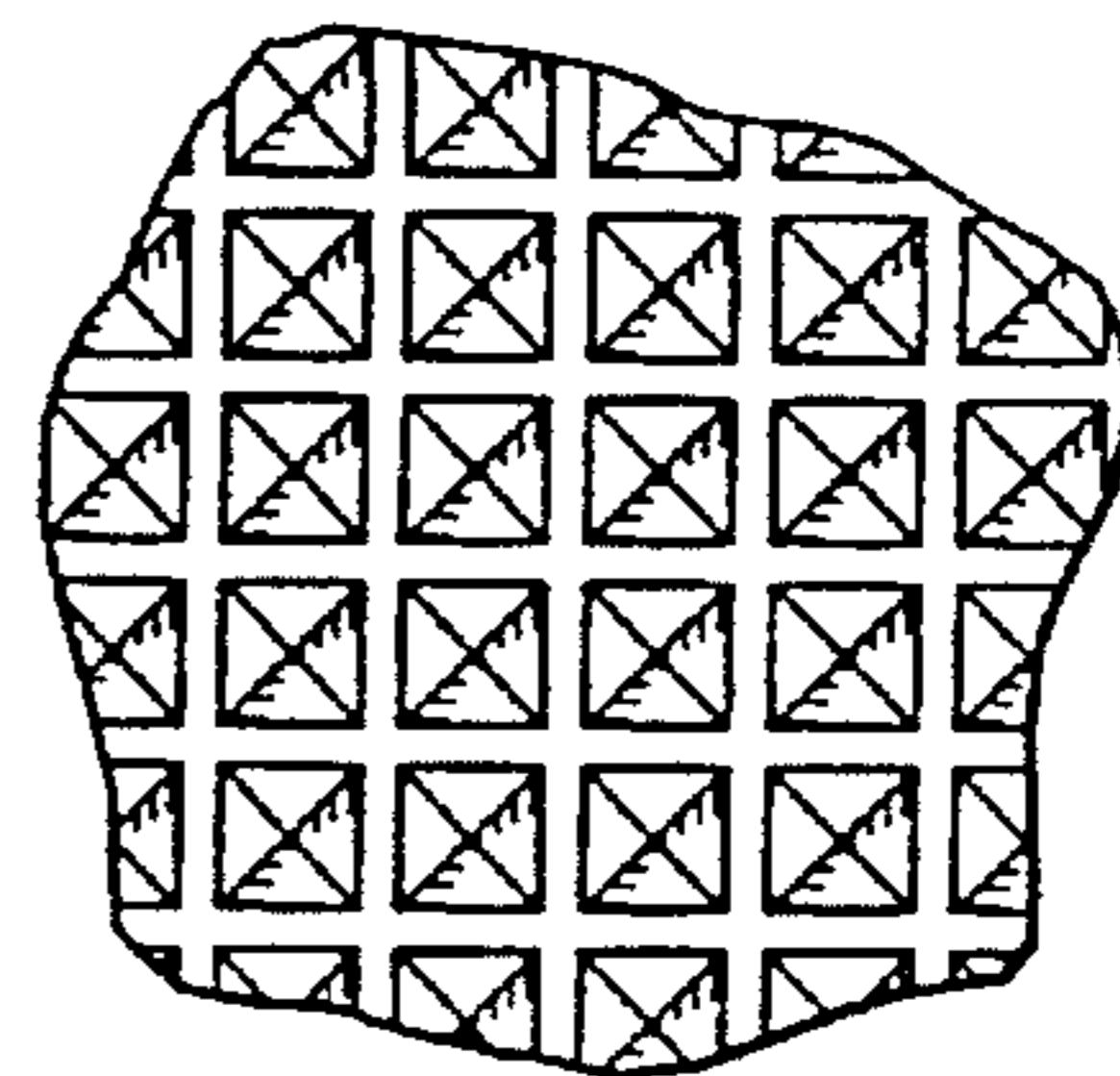

Fig. 25