



US00D377493S

# United States Patent [19]

Oda et al.

[11] Patent Number: Des. 377,493

[45] Date of Patent: \*\*Jan. 21, 1997

[54] PISTON

[75] Inventors: Hideyuki Oda; Nobuaki Murakami; Katsunori Ueda; Kyoya Igarashi; Hiromitsu Ando; Satoshi Yoshikawa; Kenji Goto; Takashi Kawabe, all of Tokyo, Japan

[73] Assignee: Mitsubishi Jidosha Kogyo Kabushiki Kaisha, Tokyo, Japan

[\*\*] Term: 14 Years

[21] Appl. No.: 46,477

[22] Filed: Nov. 15, 1995

### [30] Foreign Application Priority Data

May 16, 1995	[JP]	Japan	7-117555
Sep. 11, 1995	[JP]	Japan	7-26710
Sep. 11, 1995	[JP]	Japan	7-26711
Sep. 11, 1995	[JP]	Japan	7-26712
Sep. 11, 1995	[JP]	Japan	7-26713
Sep. 11, 1995	[JP]	Japan	7-26714
Sep. 11, 1995	[JP]	Japan	7-26715
Sep. 11, 1995	[JP]	Japan	7-233129

[52] U.S. Cl. D15/5; 123/193.6

[58] Field of Search D15/5, 6, 7, 8; 123/193.6, 193.4; 261/85

### [56] References Cited

#### U.S. PATENT DOCUMENTS

D. 122,922	10/1940	Flammang et al.	D15/5
1,674,733	6/1928	Maher	123/193.8
1,883,637	10/1932	Edwards	D15/5 X
3,123,899	3/1964	Townhill	123/193.6 X
4,271,803	6/1981	Nakanishi et al.	123/193.4 X
4,541,377	9/1985	Amos	123/193.6
4,567,863	2/1986	Fletcher	123/193.6

#### OTHER PUBLICATIONS

- "Motor Fan," Sep. 1995, pp. 209-216.
- "Jidosha Kogaku," Aug. 1995, pp. 38-47.
- "News from Mitsubishi Motors," No. 2510, May 17, 1995, pp. 1-6 (an English language translation is provided).
- "Tech Briefs"—Automotive Engineering—Sep. 1995, pp. 25, 26 and 29.

Primary Examiner—Doris V. Coles  
Assistant Examiner—Frank Martinez

### [57] CLAIM

The ornamental design for a piston, as shown.

### DESCRIPTION

FIG. 1 is a perspective view showing a first embodiment of the piston showing our new design of a piston;  
 FIG. 2 is a front elevational view of the piston of FIG. 1;  
 FIG. 3 is a rear elevational view of the piston of FIG. 1;  
 FIG. 4 is a top plan view of the piston of FIG. 1;  
 FIG. 5 is bottom plan view of the piston of FIG. 1;  
 FIG. 6 is left-side elevational view of the piston of FIG. 1;  
 FIG. 7 is a right-side elevational view of the piston of FIG. 1;  
 FIG. 8 is a cross-sectional view taken along line A—A of FIG. 2;  
 FIG. 9 is a cross-sectional view taken along line B—B of FIG. 7;  
 FIG. 10 is a perspective view of a second embodiment of a piston showing our new design;  
 FIG. 11 is a front elevational view of the piston of FIG. 10;  
 FIG. 12 is a rear elevational view of the piston of FIG. 10;  
 FIG. 13 is a top plan view of the piston of FIG. 10;  
 FIG. 14 is bottom plan view of the piston of FIG. 10;  
 FIG. 15 is a left-side elevational view of the piston of FIG. 10;  
 FIG. 16 is a right-side elevational view of the piston of FIG. 10;  
 FIG. 17 is a cross-sectional view taken along line B—B of FIG. 11;  
 FIG. 18 is a cross-sectional view taken along line B—B of FIG. 16;  
 FIG. 19 is a perspective view of a third embodiment of a piston showing our new design;  
 FIG. 20 is a front elevational view of the piston of FIG. 19;  
 FIG. 21 is a rear elevational view of the piston of FIG. 19;  
 FIG. 22 is a top plan view of the piston of FIG. 19;  
 FIG. 23 is bottom plan view of the piston of FIG. 19;  
 FIG. 24 is a left-side elevational view of the piston of FIG. 19;  
 FIG. 25 is a right-side elevational view of the piston of FIG. 19;  
 FIG. 26 is a cross-sectional view taken along line A—A of FIG. 20;

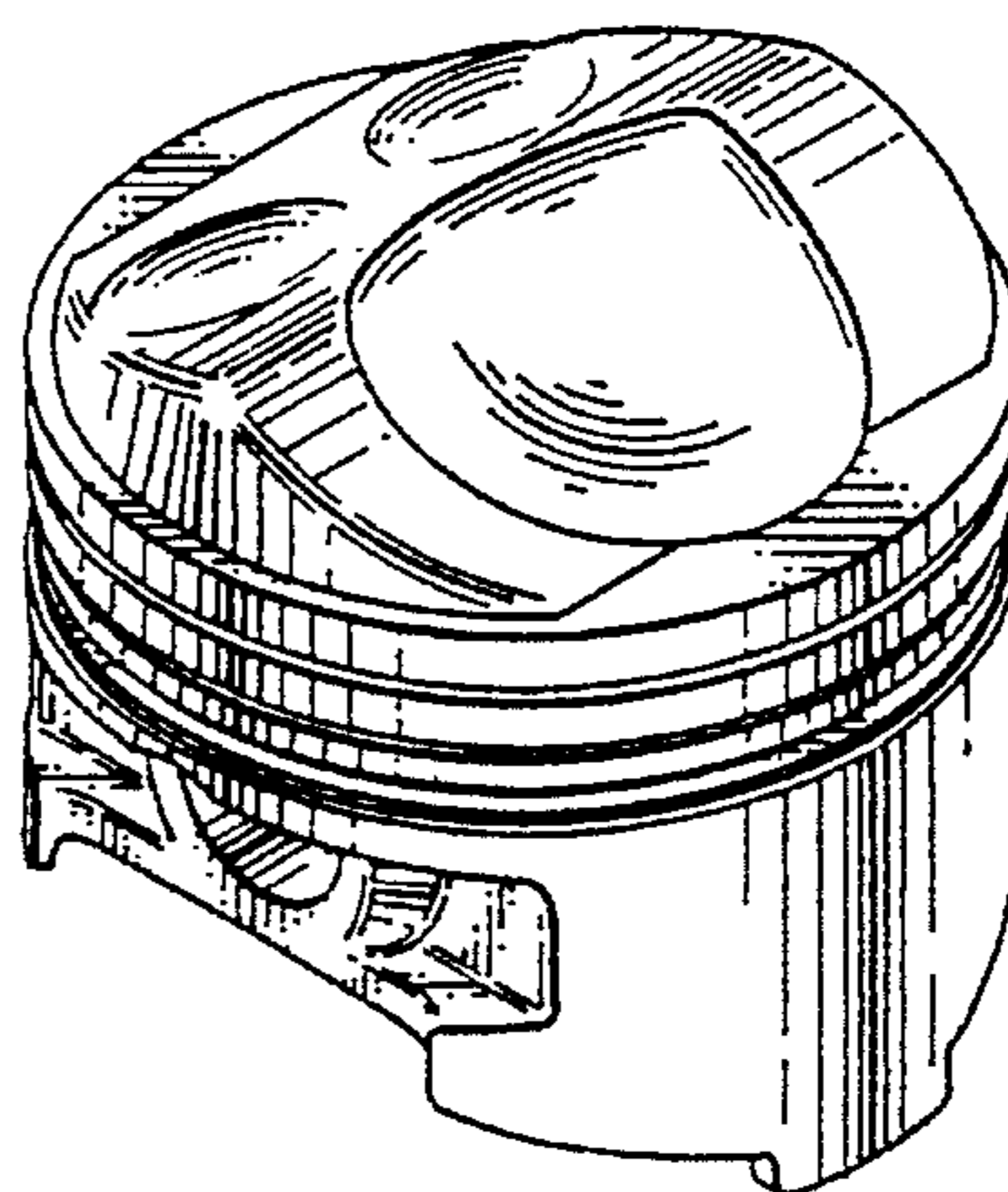
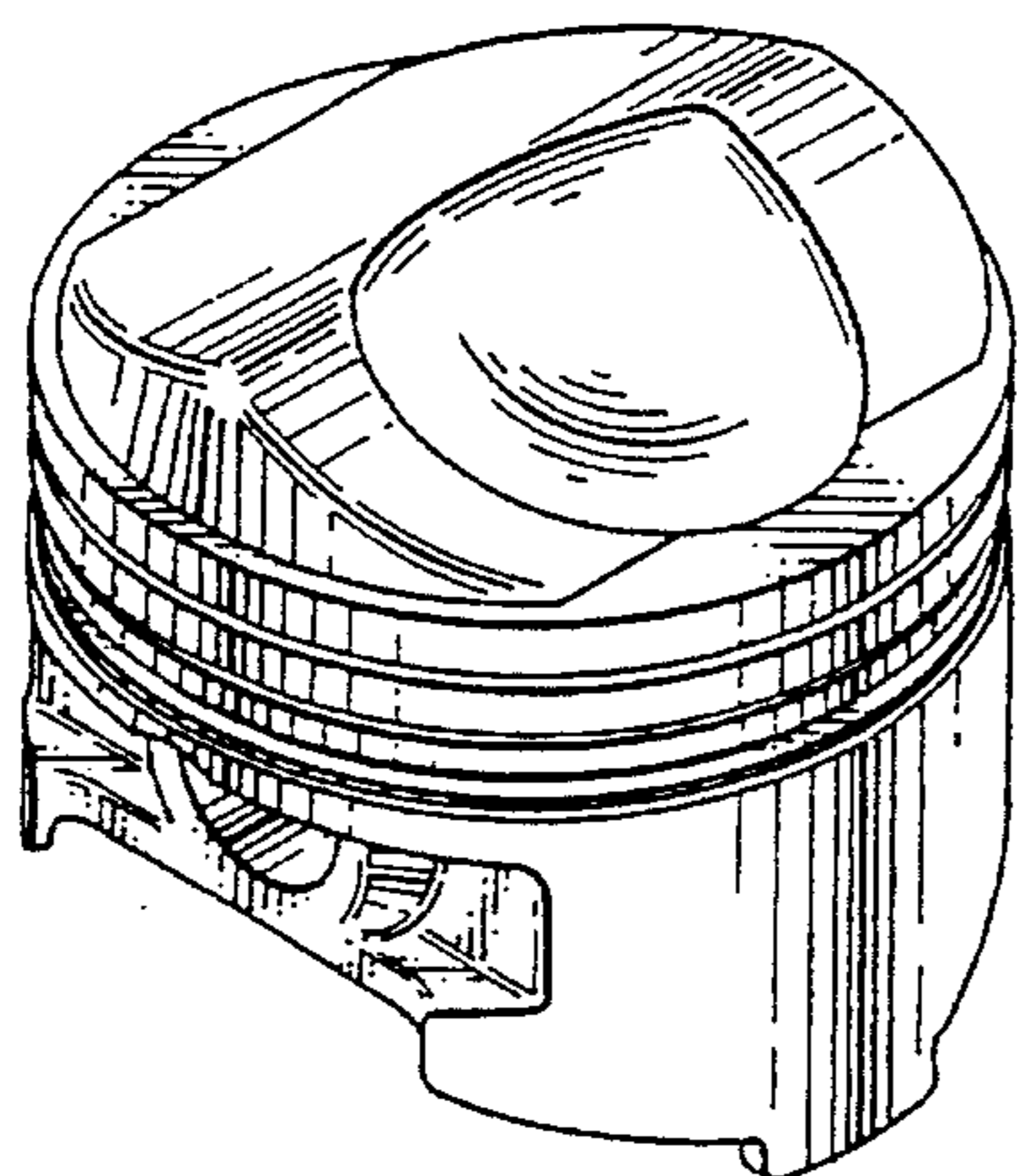

FIG. 27 is a cross-sectional view taken along line B—B of FIG. 25;

FIG. 28 is a perspective view of a fourth embodiment of a piston showing our new design;

FIG. 29 is a front elevational view of the piston of FIG. 28;

FIG. 30 is a rear elevational view of the piston of FIG. 28;

FIG. 31 is a top plan view of the piston of FIG. 28;

FIG. 32 is bottom plan view of the piston of FIG. 28;

FIG. 33 is a left-side elevational view of the piston of FIG. 28;

FIG. 34 is a right-side elevational view of the piston of FIG. 28;

FIG. 35 is a cross-sectional view taken along line A—A of FIG. 29;

FIG. 36 is a cross-sectional view taken along line B—B of FIG. 34;

FIG. 37 is a perspective view of a fifth embodiment of a piston showing our new design;

FIG. 38 is a front elevational view of the piston of FIG. 37;

FIG. 39 is a rear elevational view of the piston of FIG. 37;

FIG. 40 is a top plan view of the piston of FIG. 37;

FIG. 41 is a bottom plan view of the piston of FIG. 37;

FIG. 42 is a left-side elevational view of the piston of FIG. 37;

FIG. 43 is a right-side elevational view of the piston of FIG. 37;

FIG. 44 is a cross-sectional view taken along line A—A of FIG. 38;

FIG. 45 is a cross-sectional view taken along line B—B of FIG. 43;

FIG. 46 is a perspective view of a sixth embodiment of a piston showing our new design;

FIG. 47 is a front elevational view of the piston of FIG. 46;

FIG. 48 is a rear elevational view of the piston of FIG. 46;

FIG. 49 is a top plan view of the piston of FIG. 46;

FIG. 50 is bottom plan view of the piston of FIG. 46;

FIG. 51 is a left-side elevational view of the piston of FIG. 46;

FIG. 52 is a right-side elevational view of the piston of FIG. 46;

FIG. 53 is a cross-sectional view taken along line A—A of FIG. 47; and,

FIG. 54 is a cross-sectional view taken along line B—B of FIG. 52.

**1 Claim, 18 Drawing Sheets**

FIG. 1

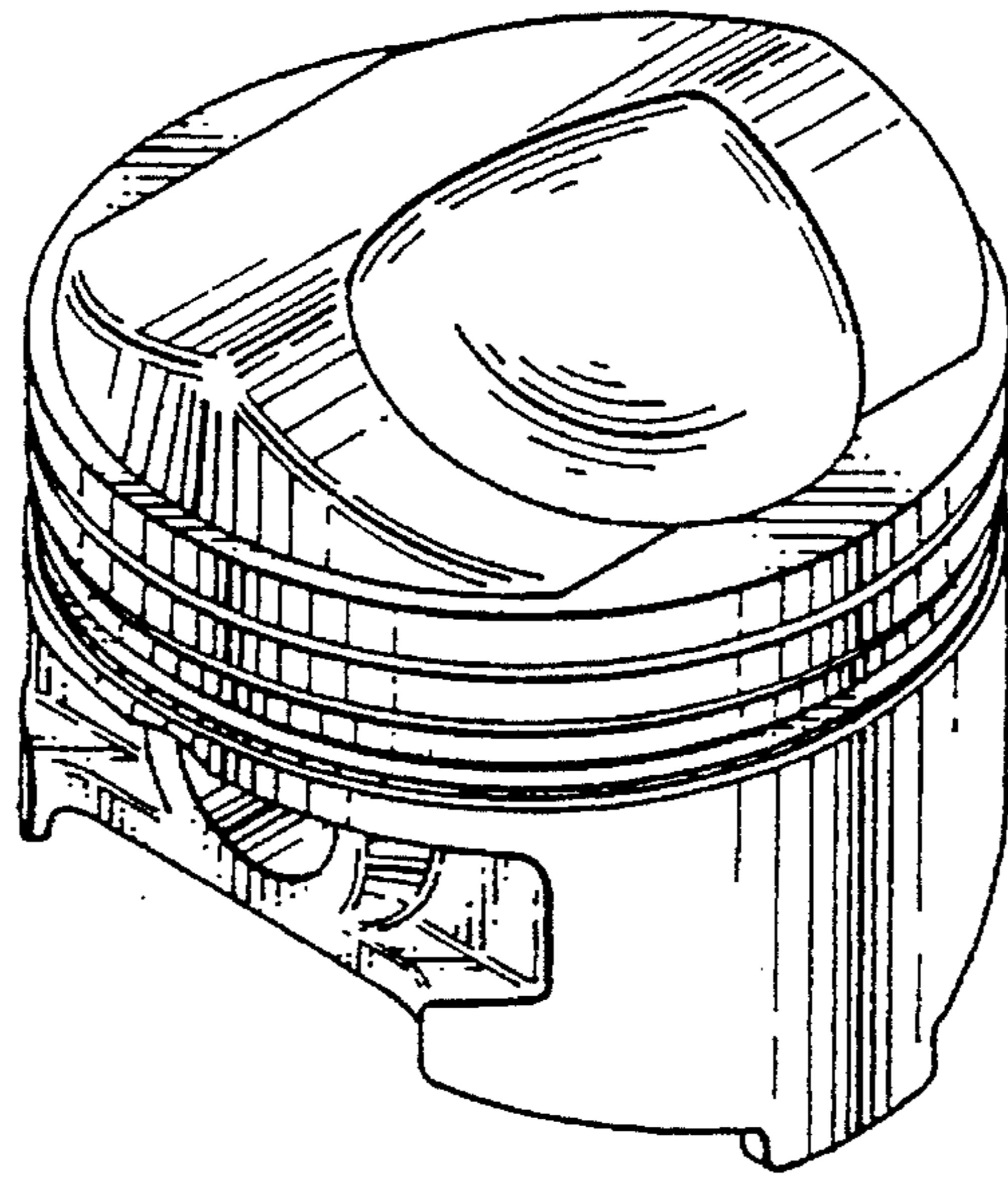

FIG. 2

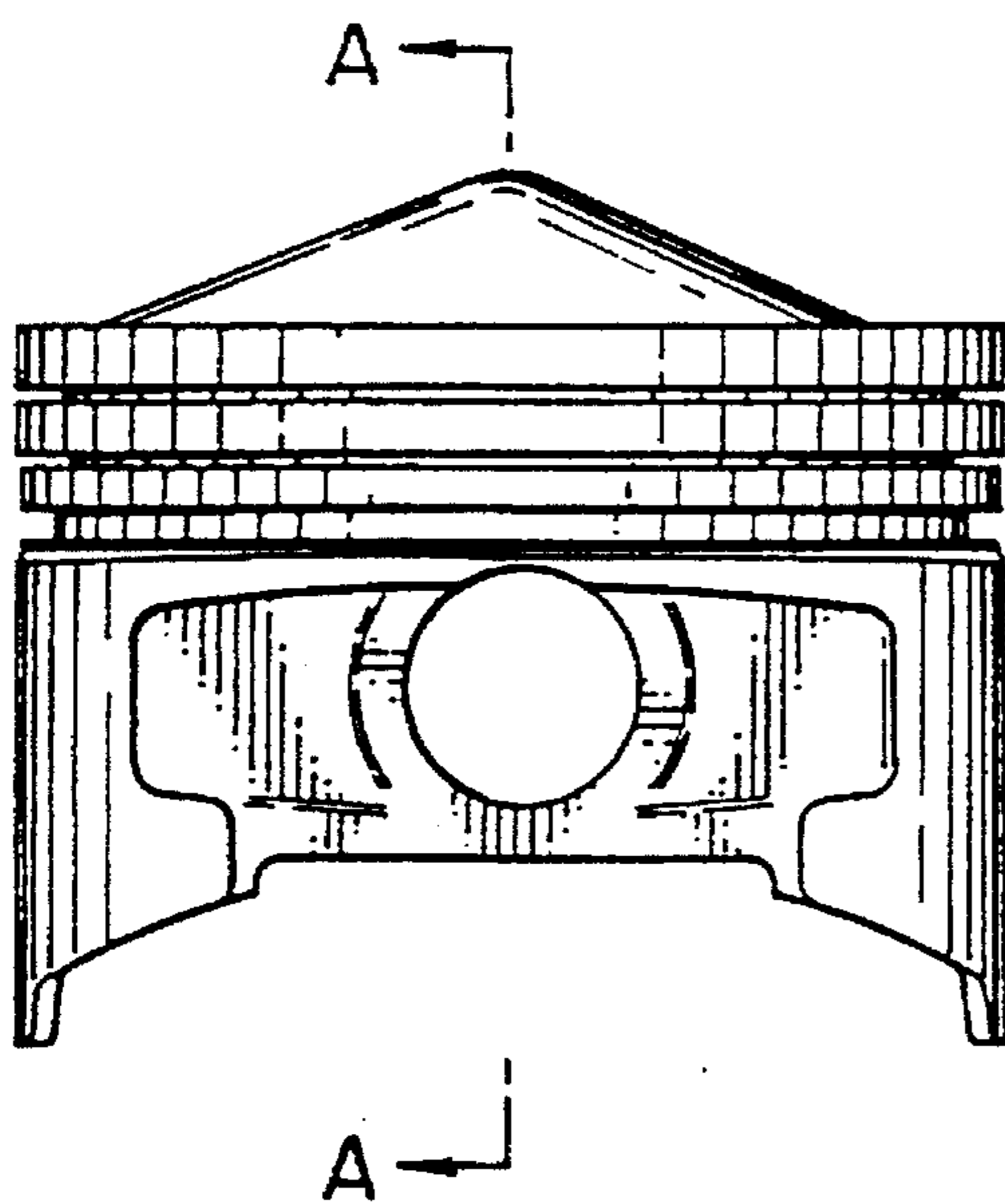

FIG. 3

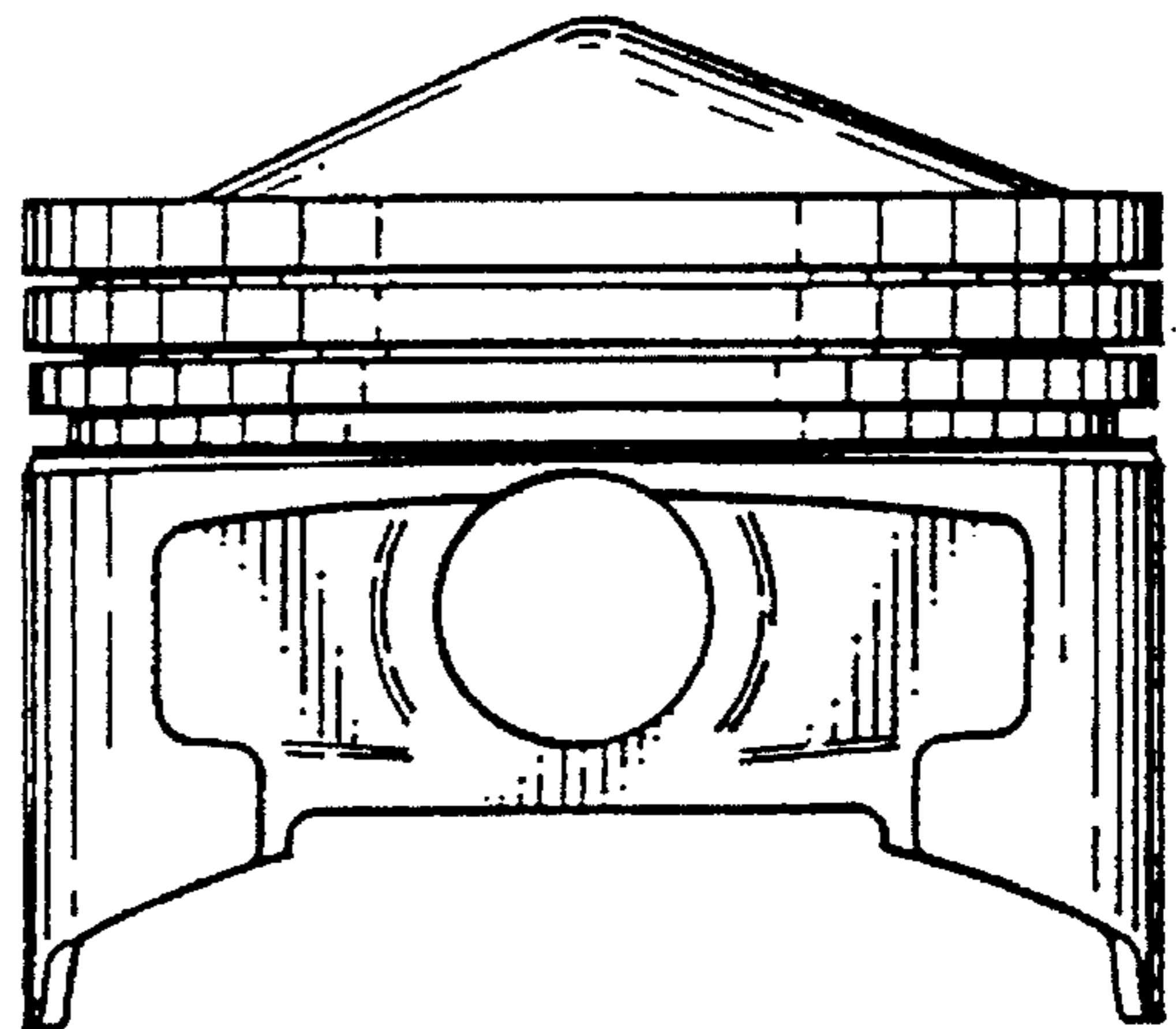

FIG. 4

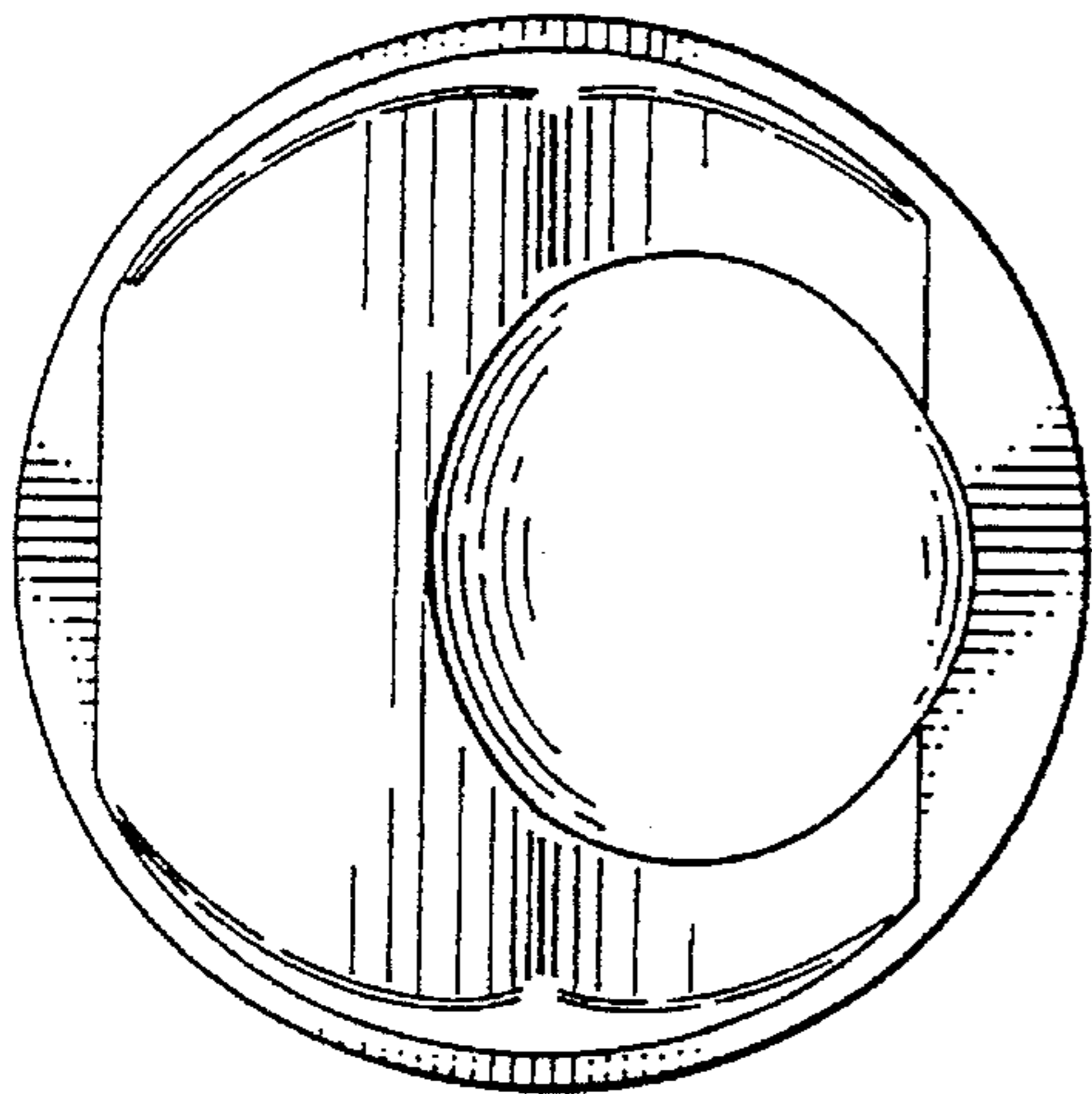

FIG. 5

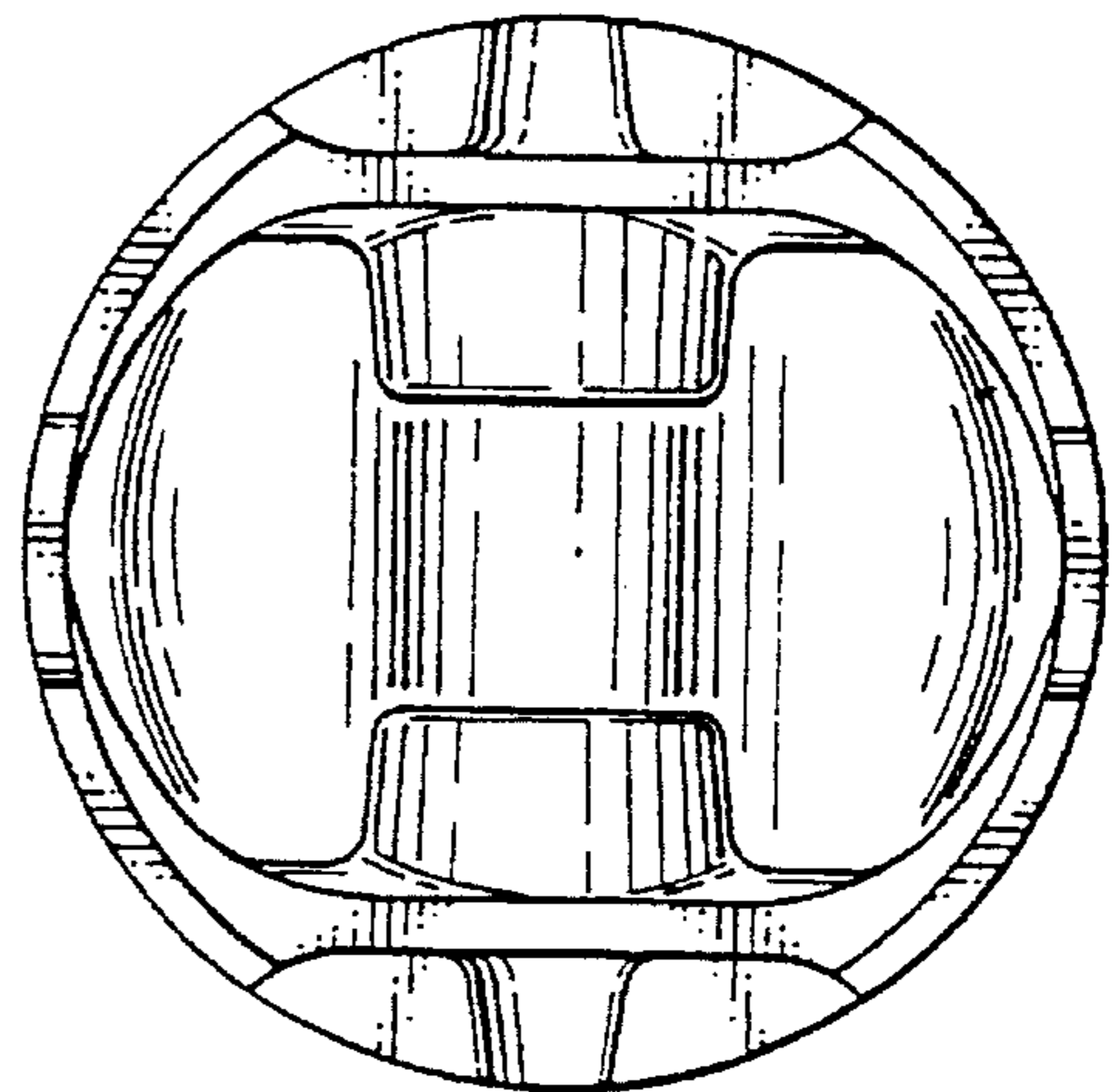

FIG. 6

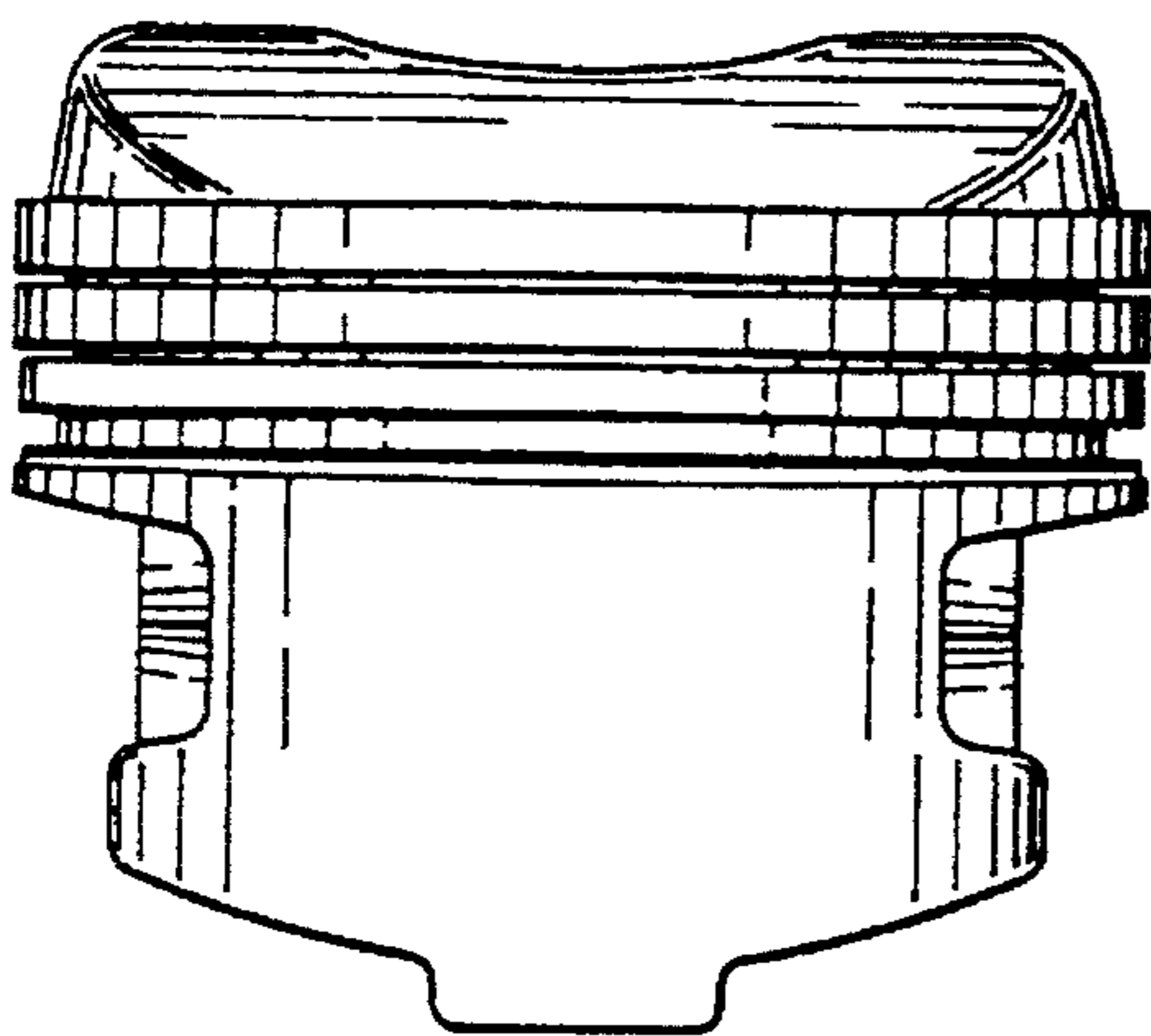

FIG. 7

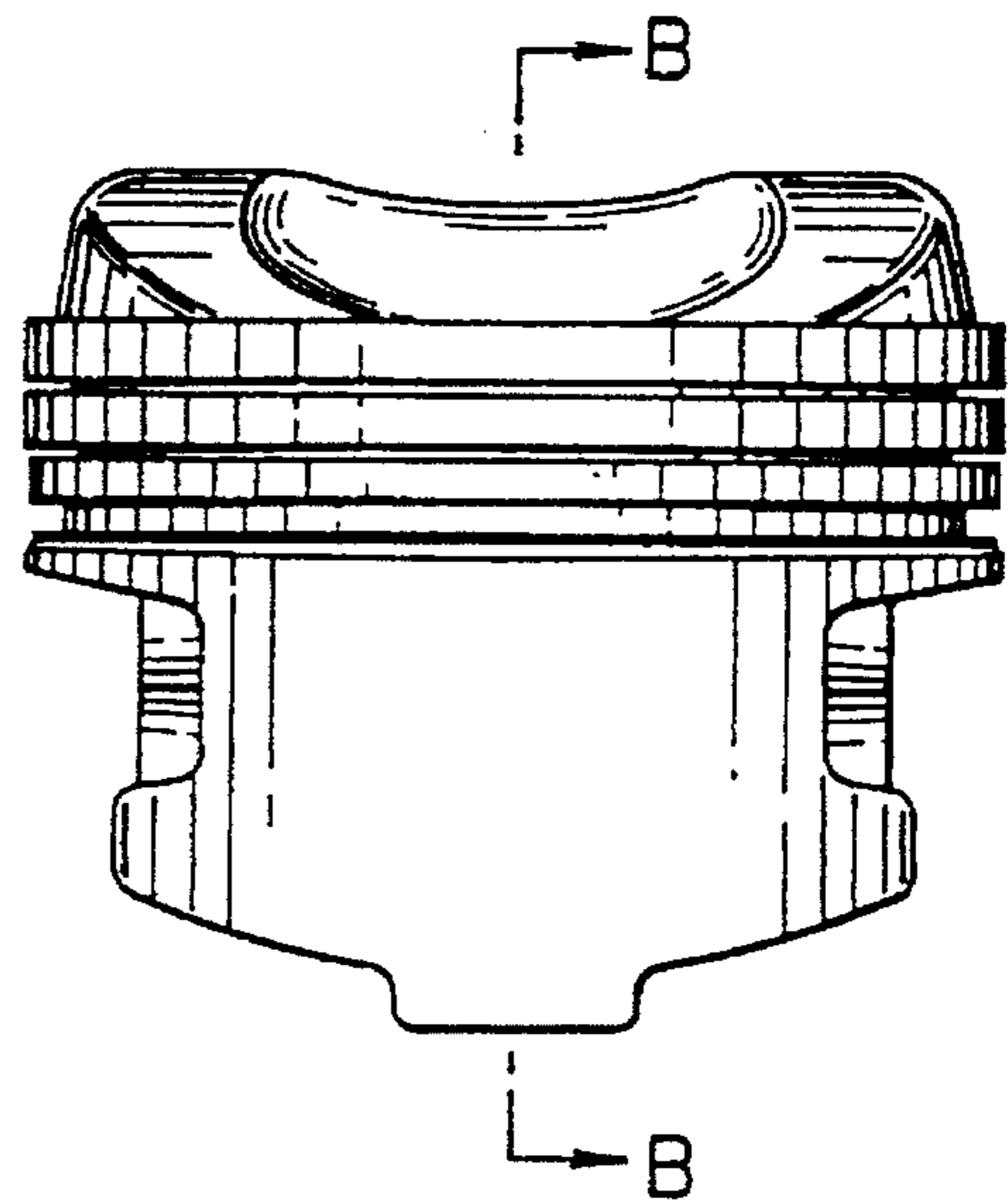

FIG. 8

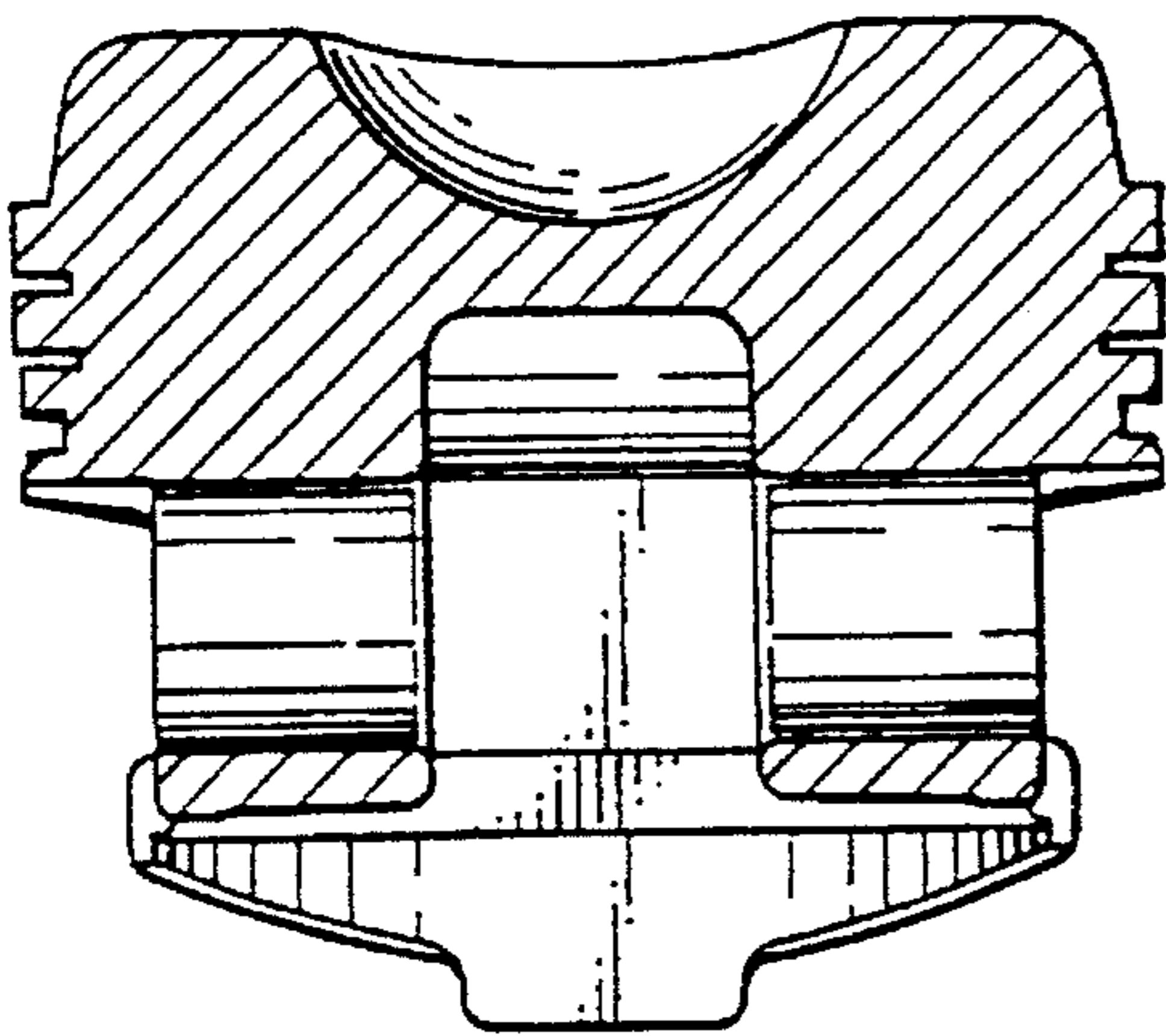

FIG. 9

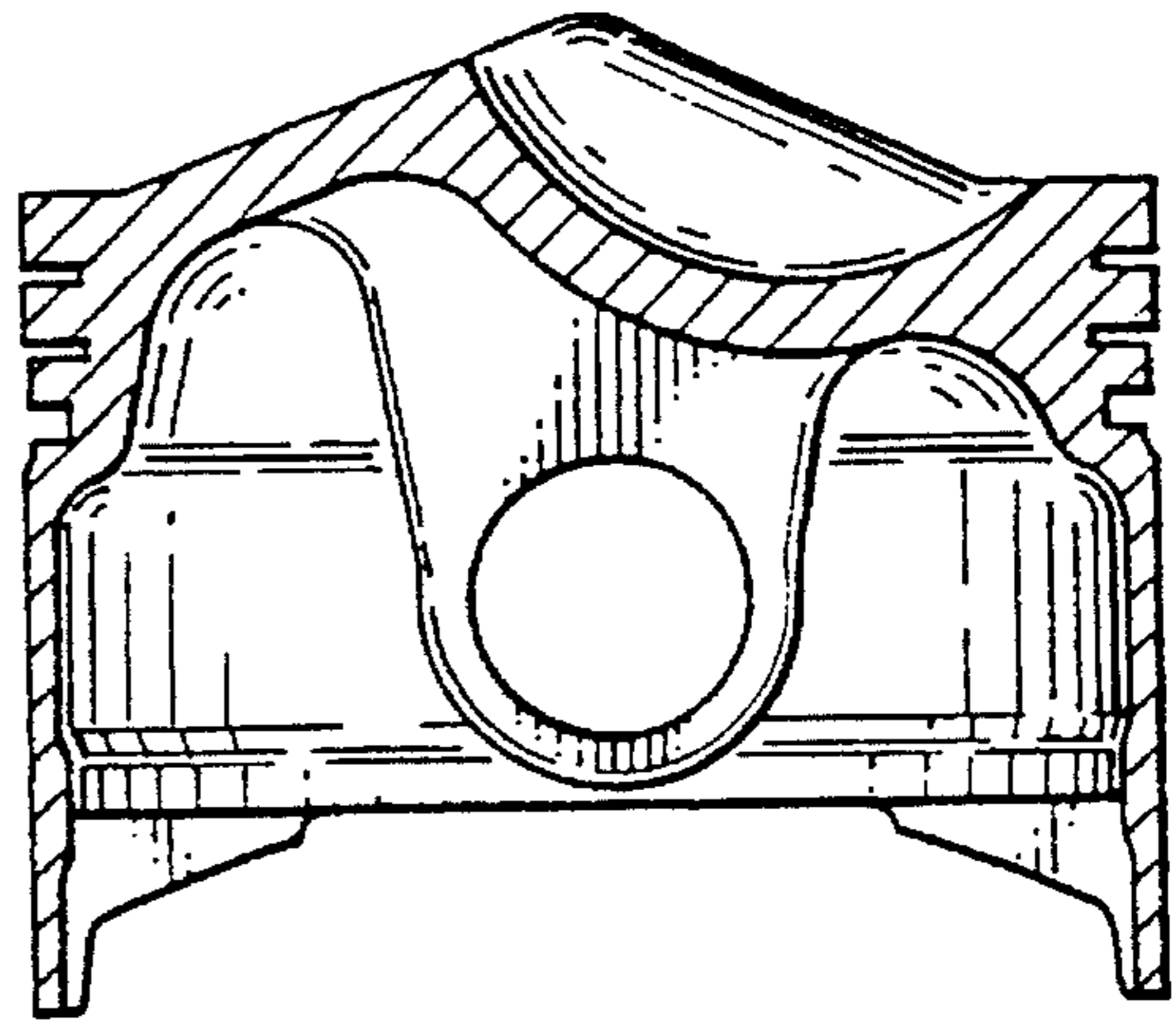

FIG. 10

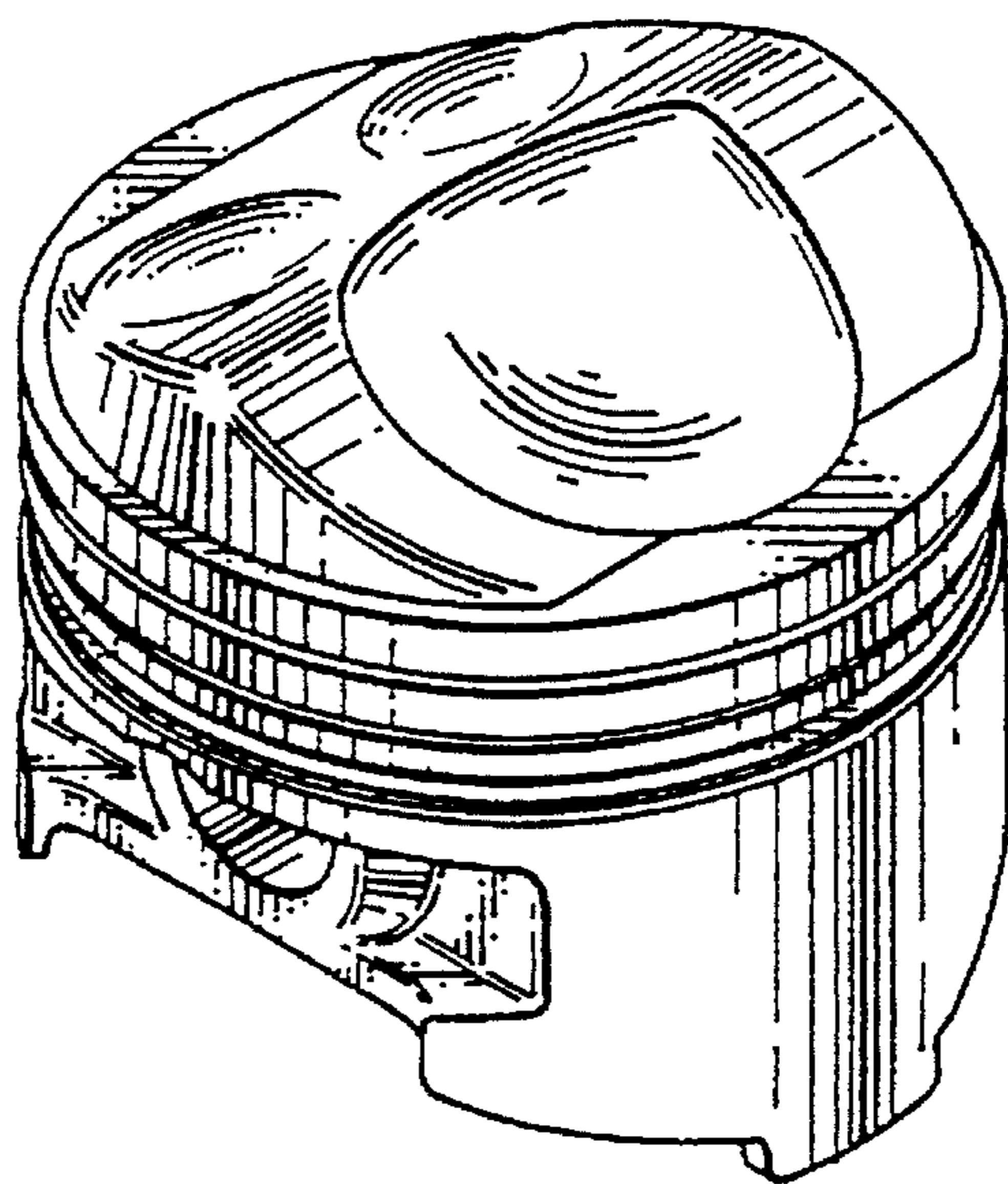

FIG. 11

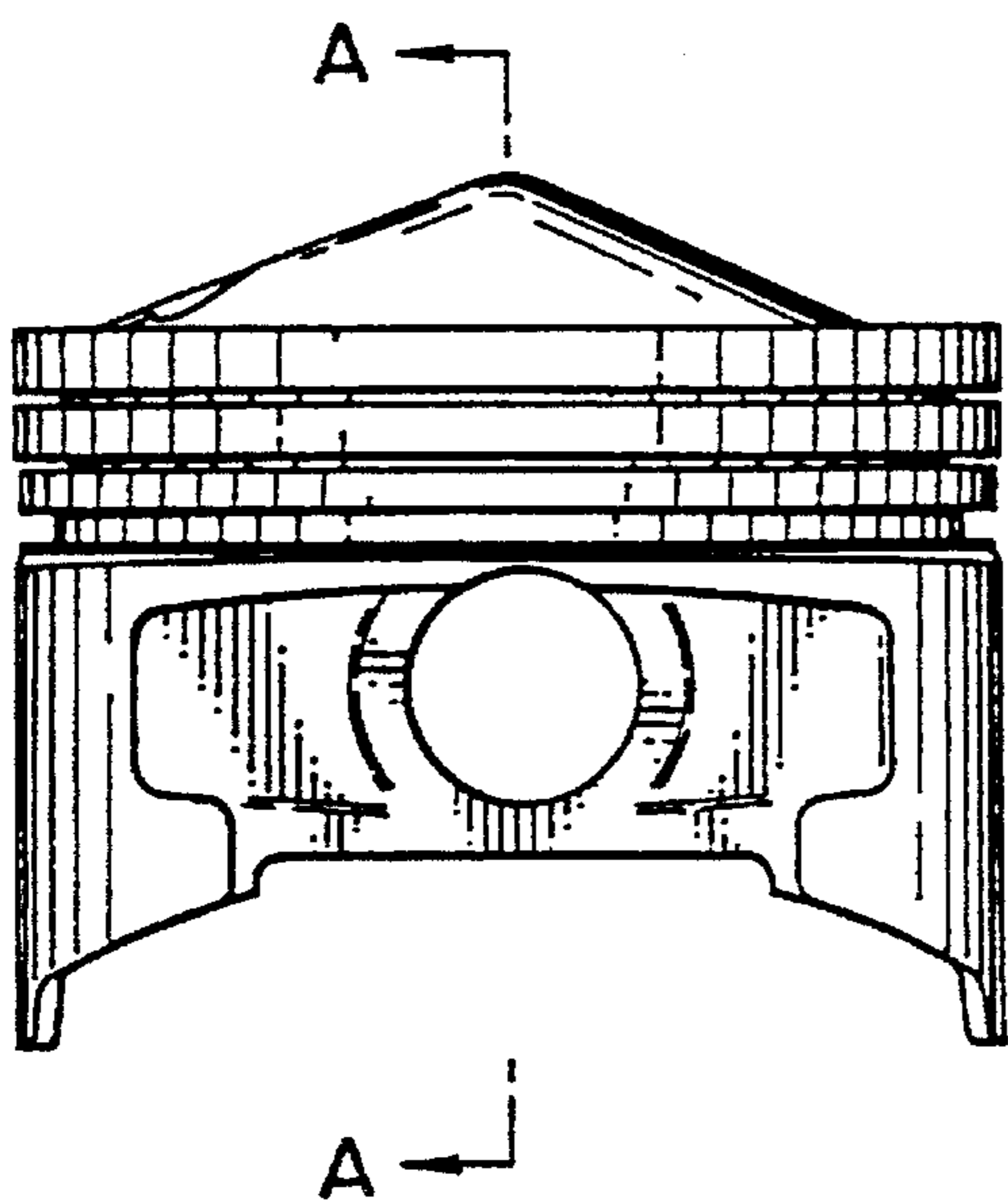

FIG. 12

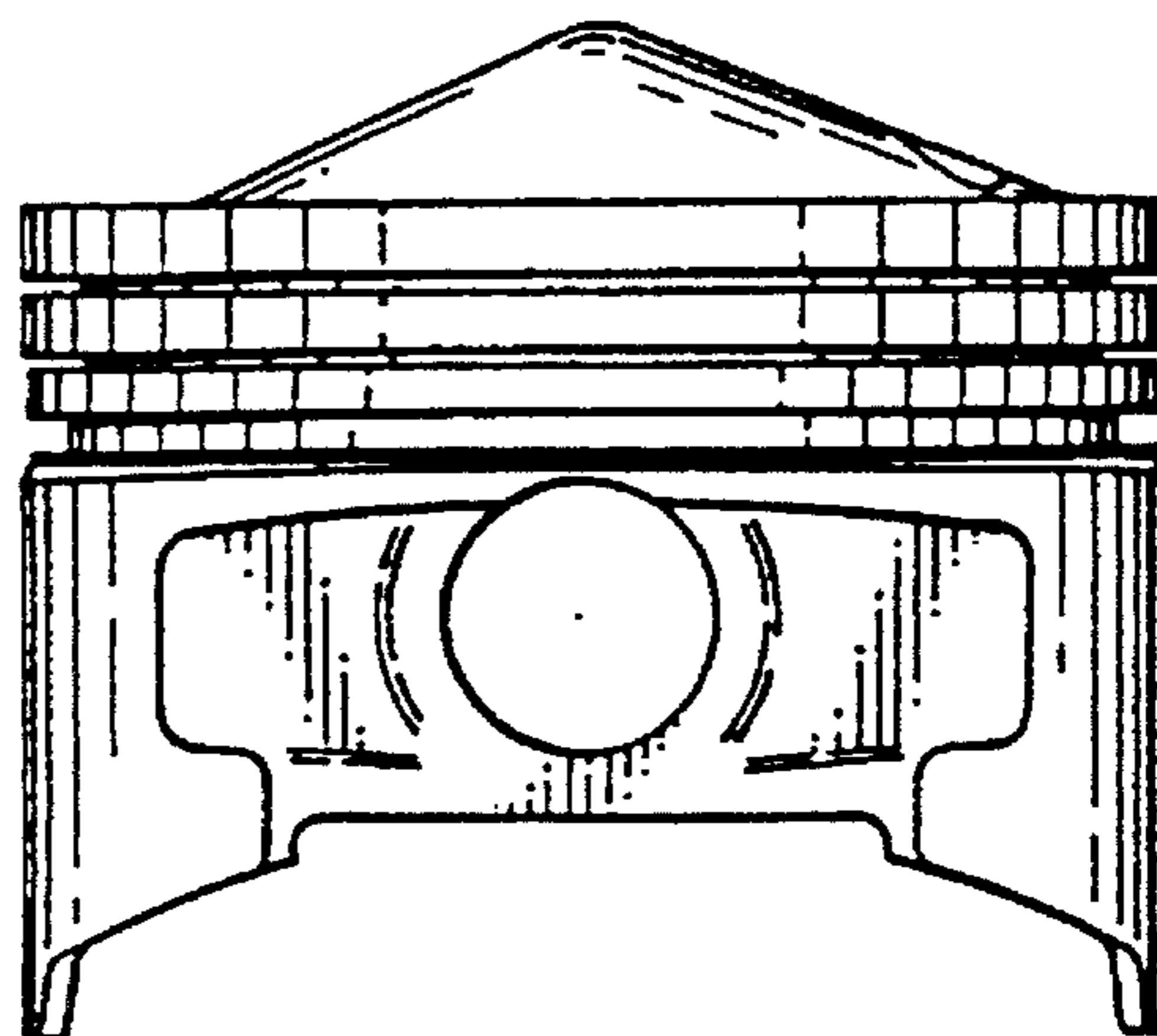

FIG. 13

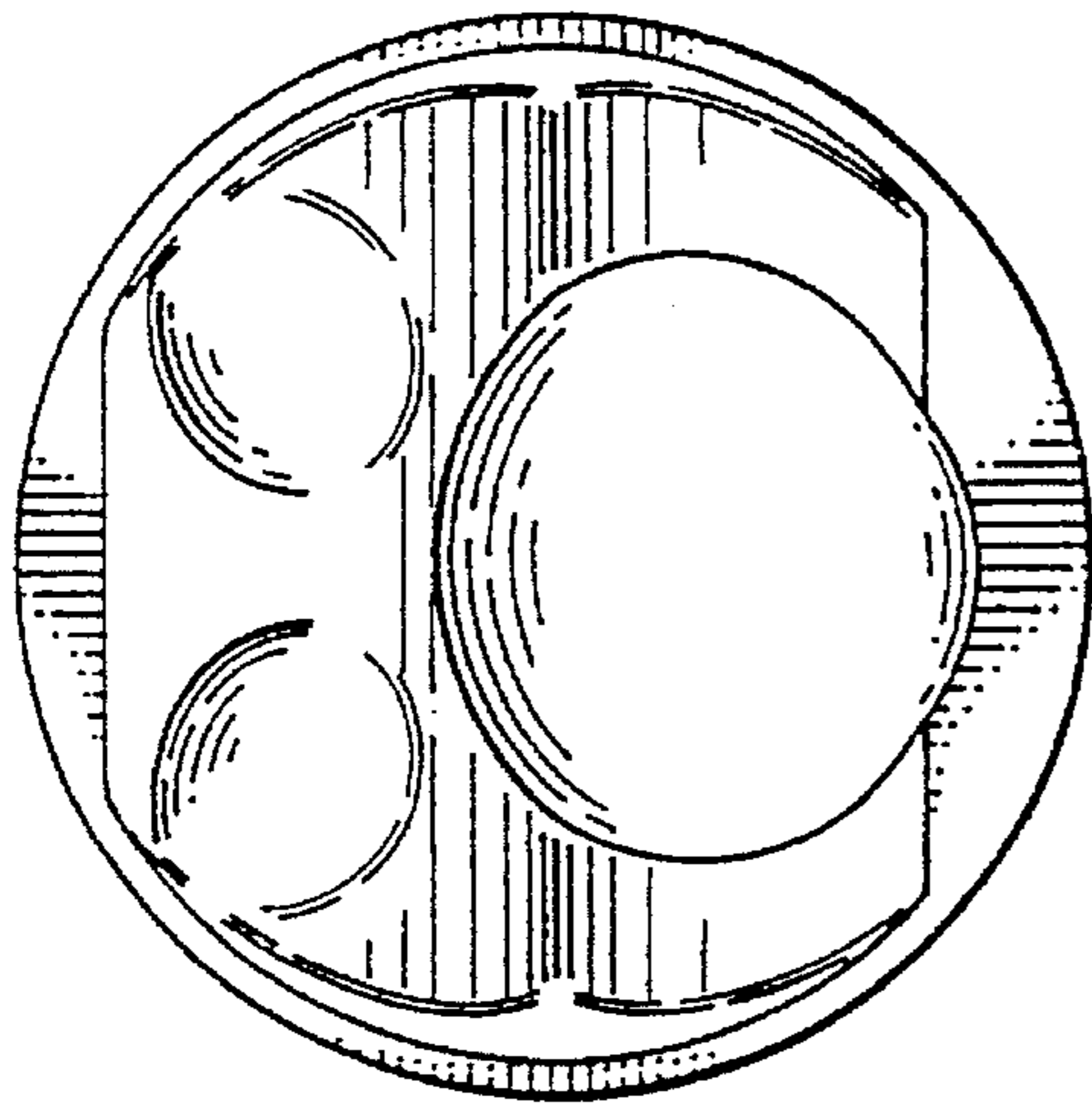

FIG. 14

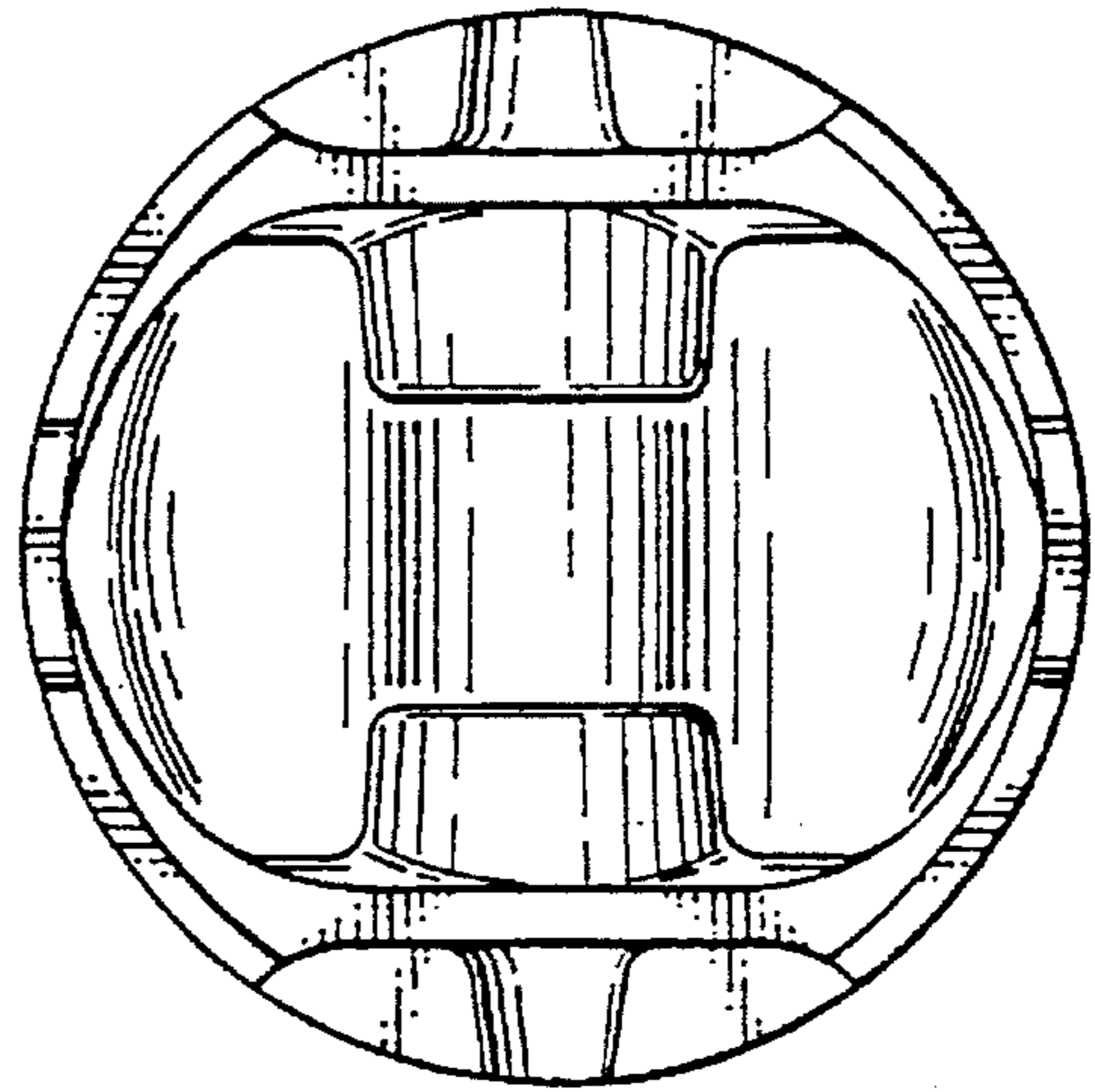

FIG. 15

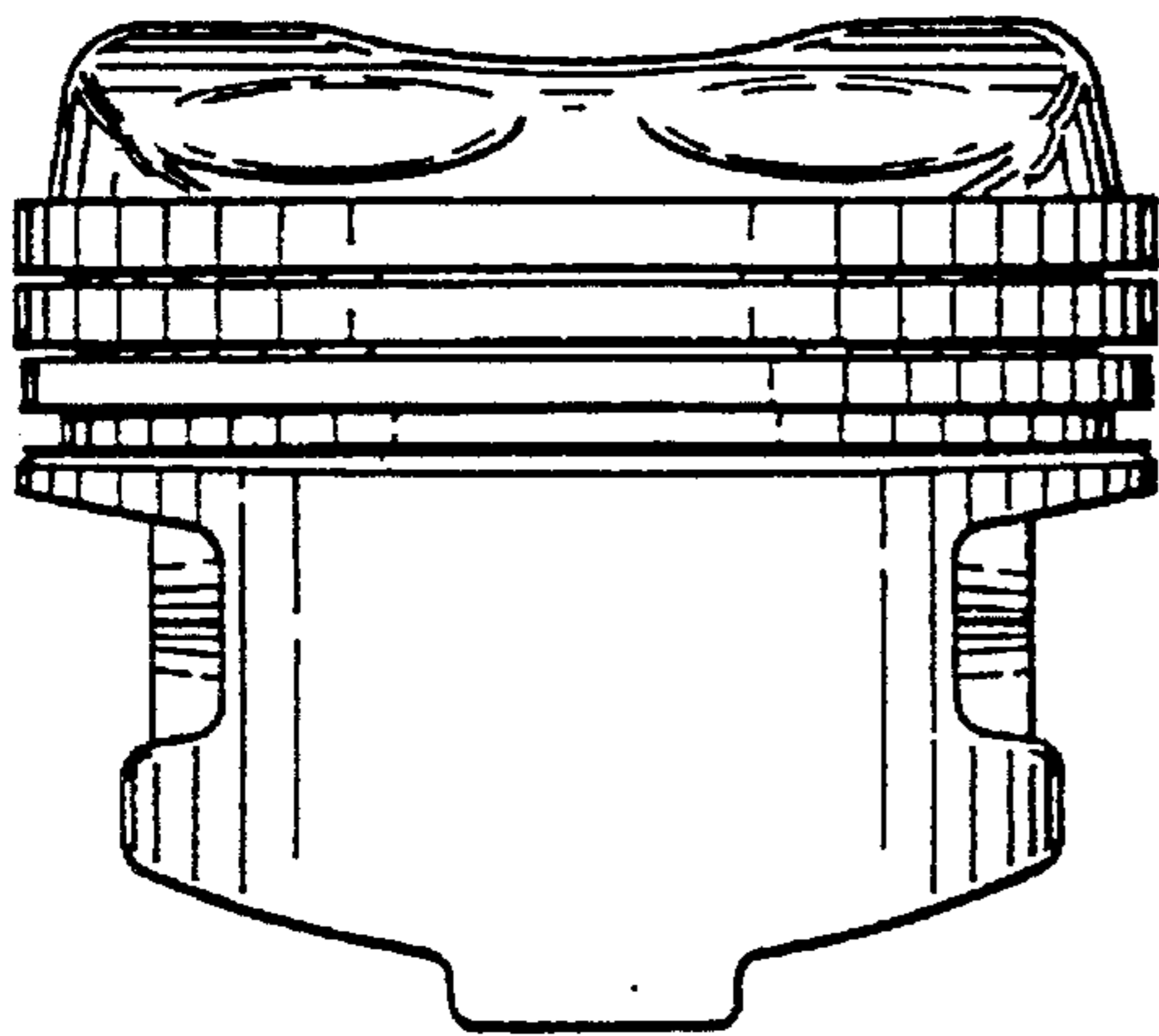

FIG. 16

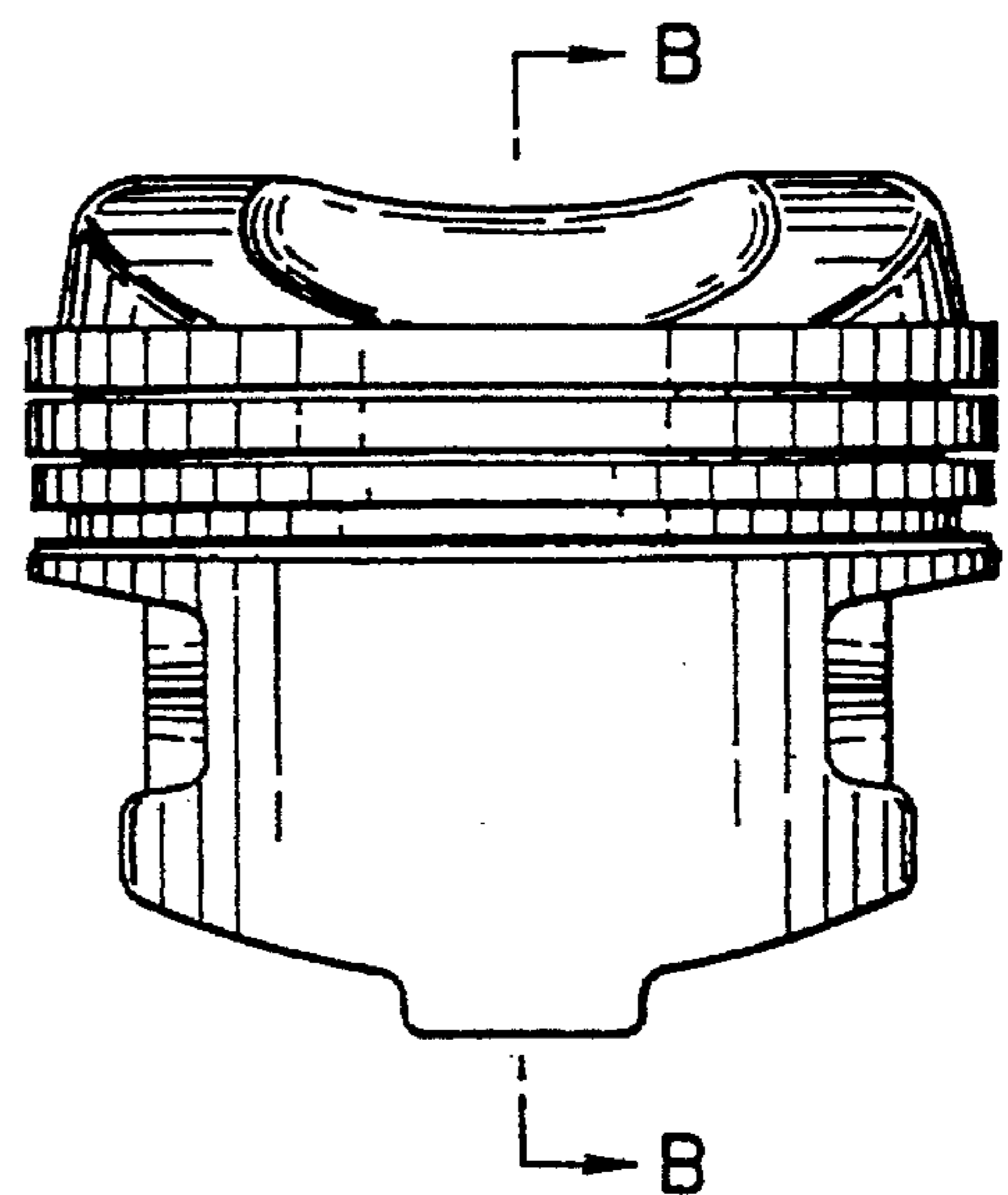

FIG. 17

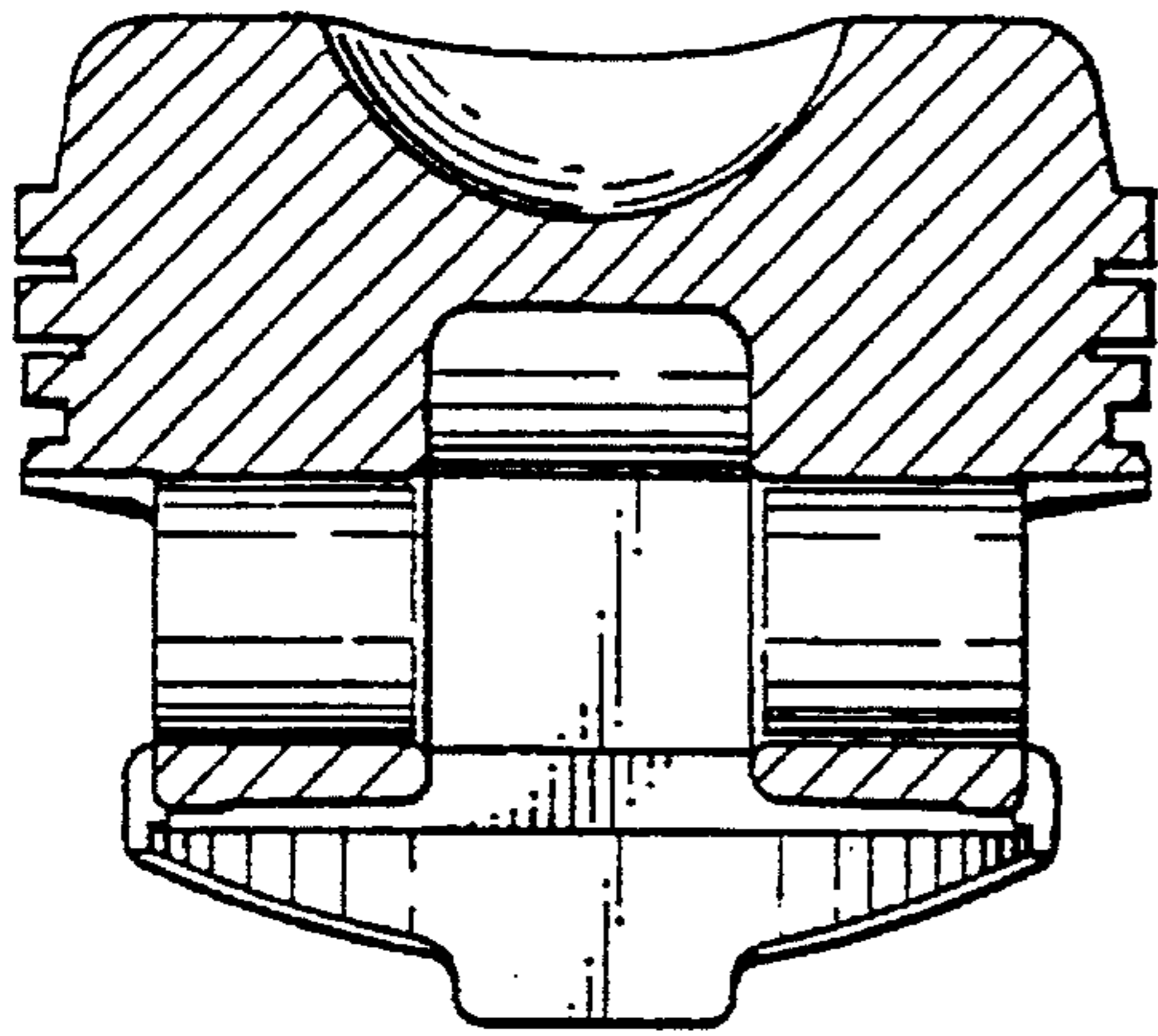

FIG. 18

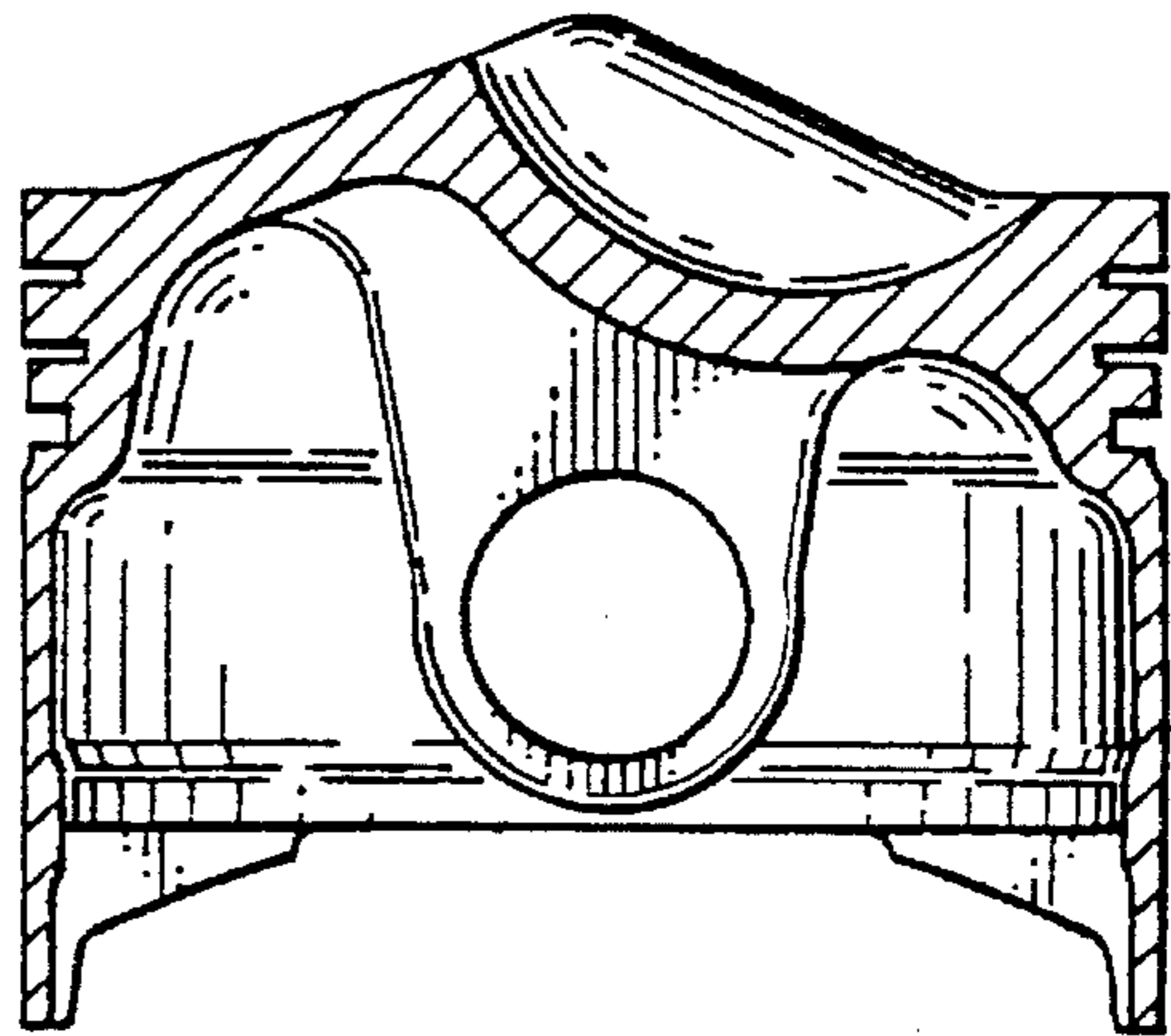



FIG. 19

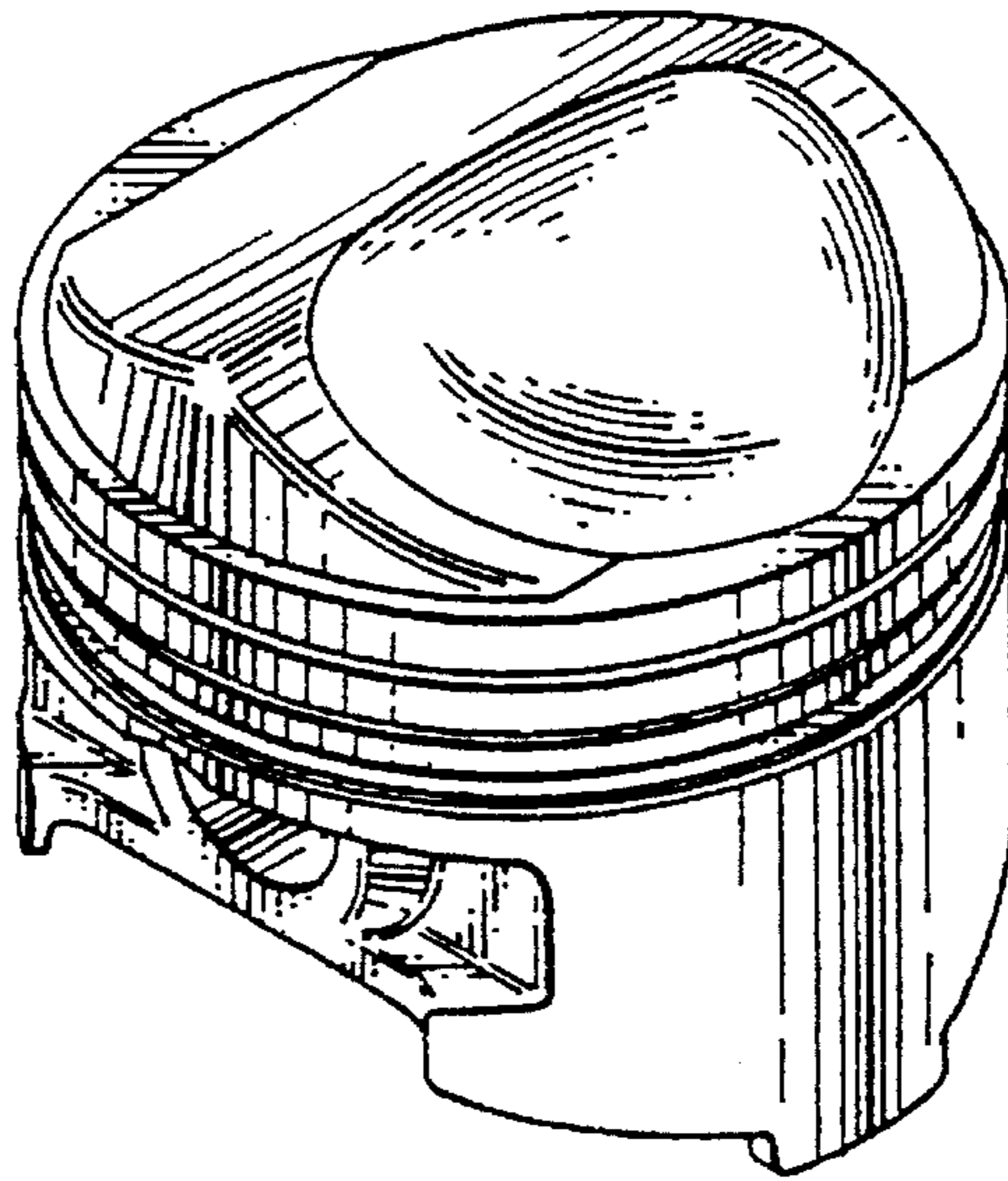

FIG. 20

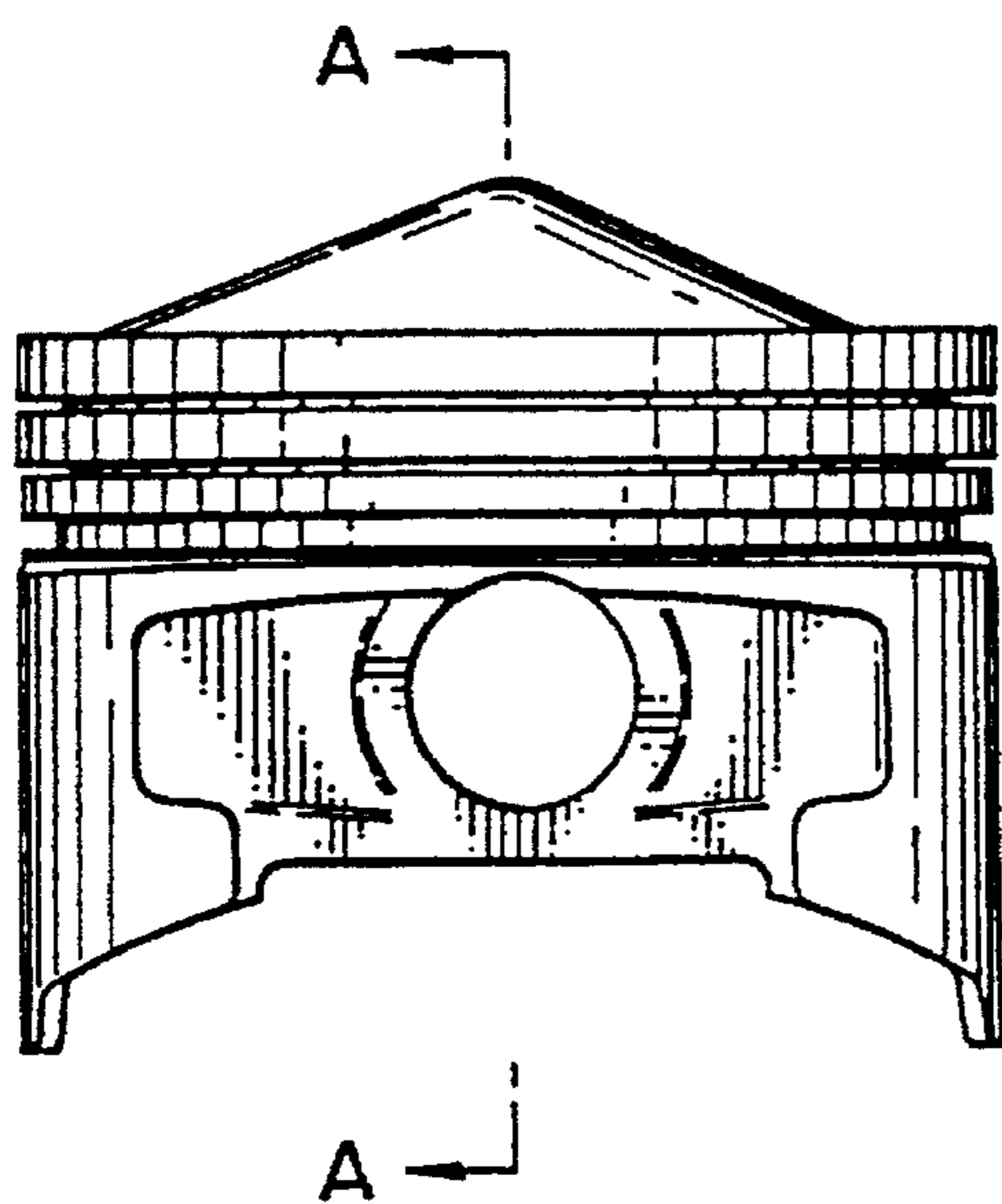

FIG. 21

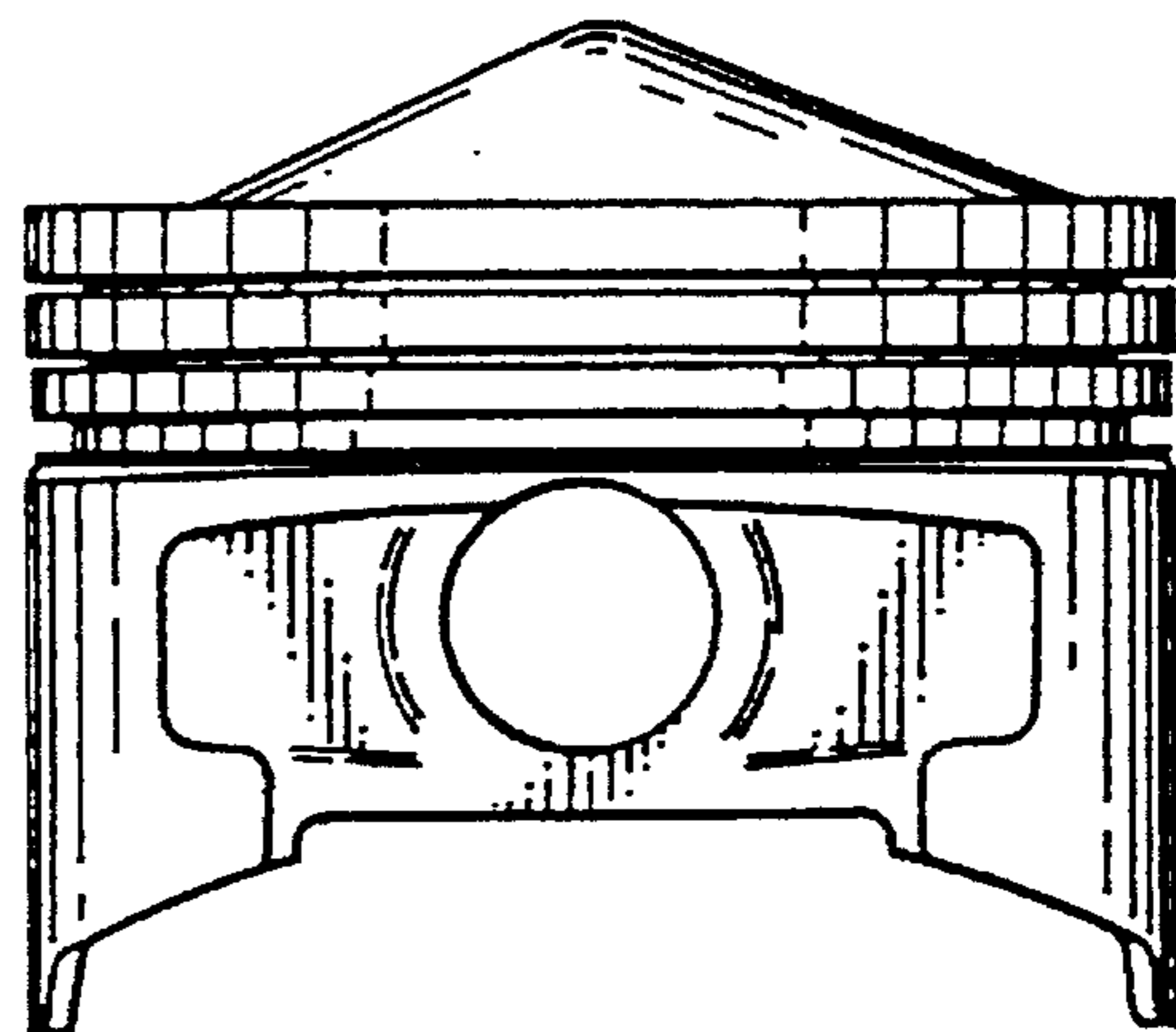

FIG. 22

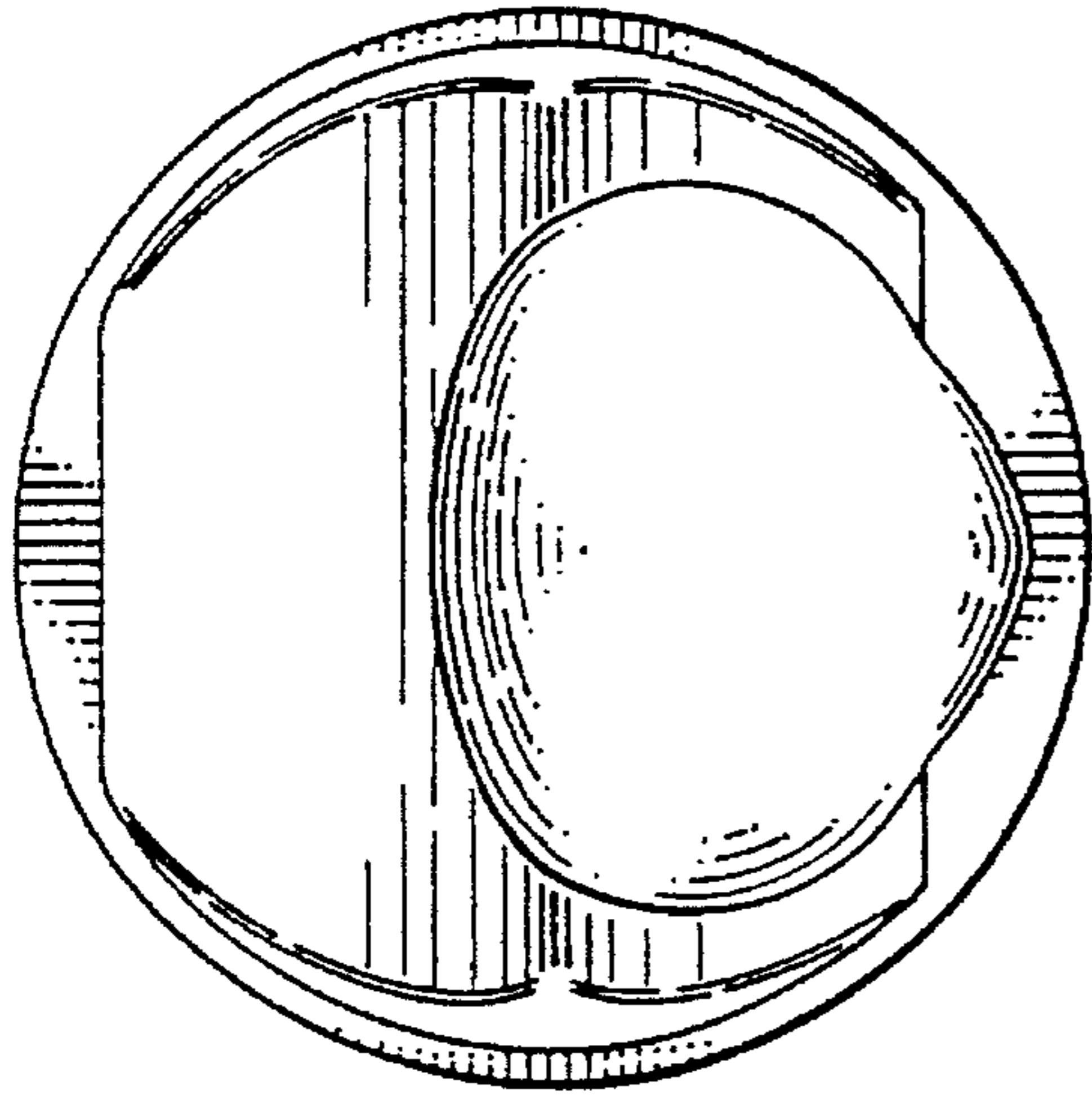

FIG. 23

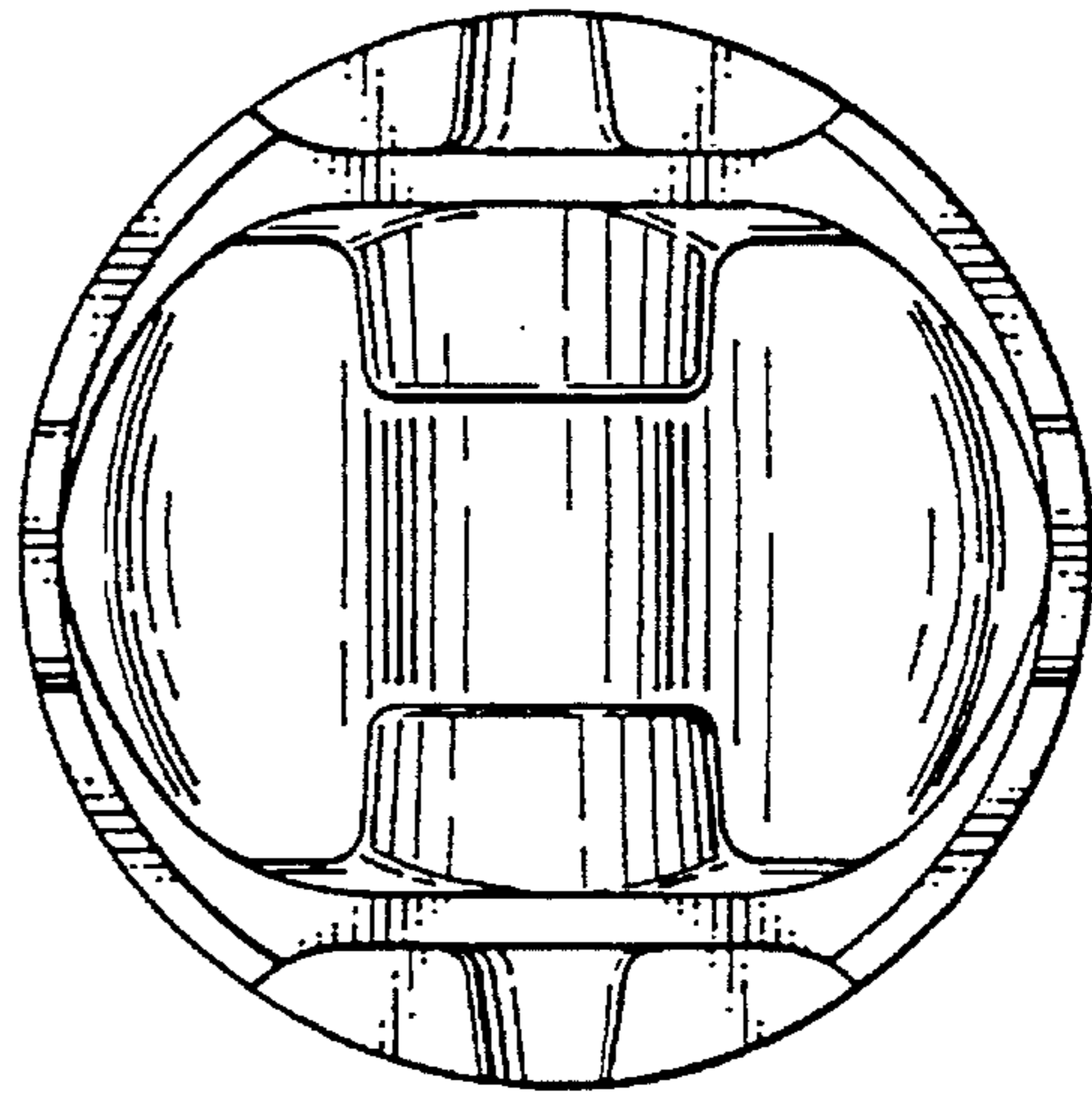

FIG. 24

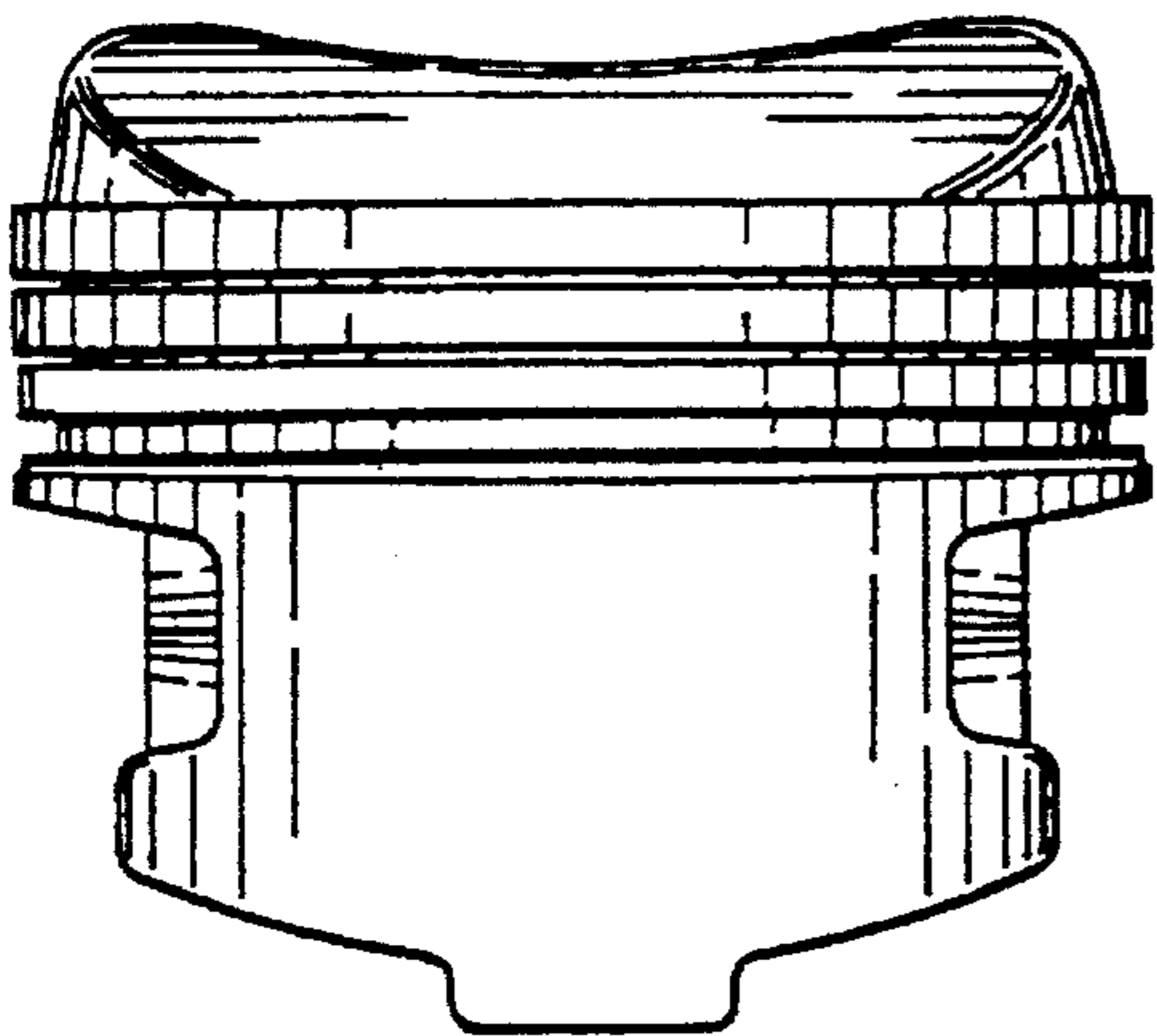

FIG. 25

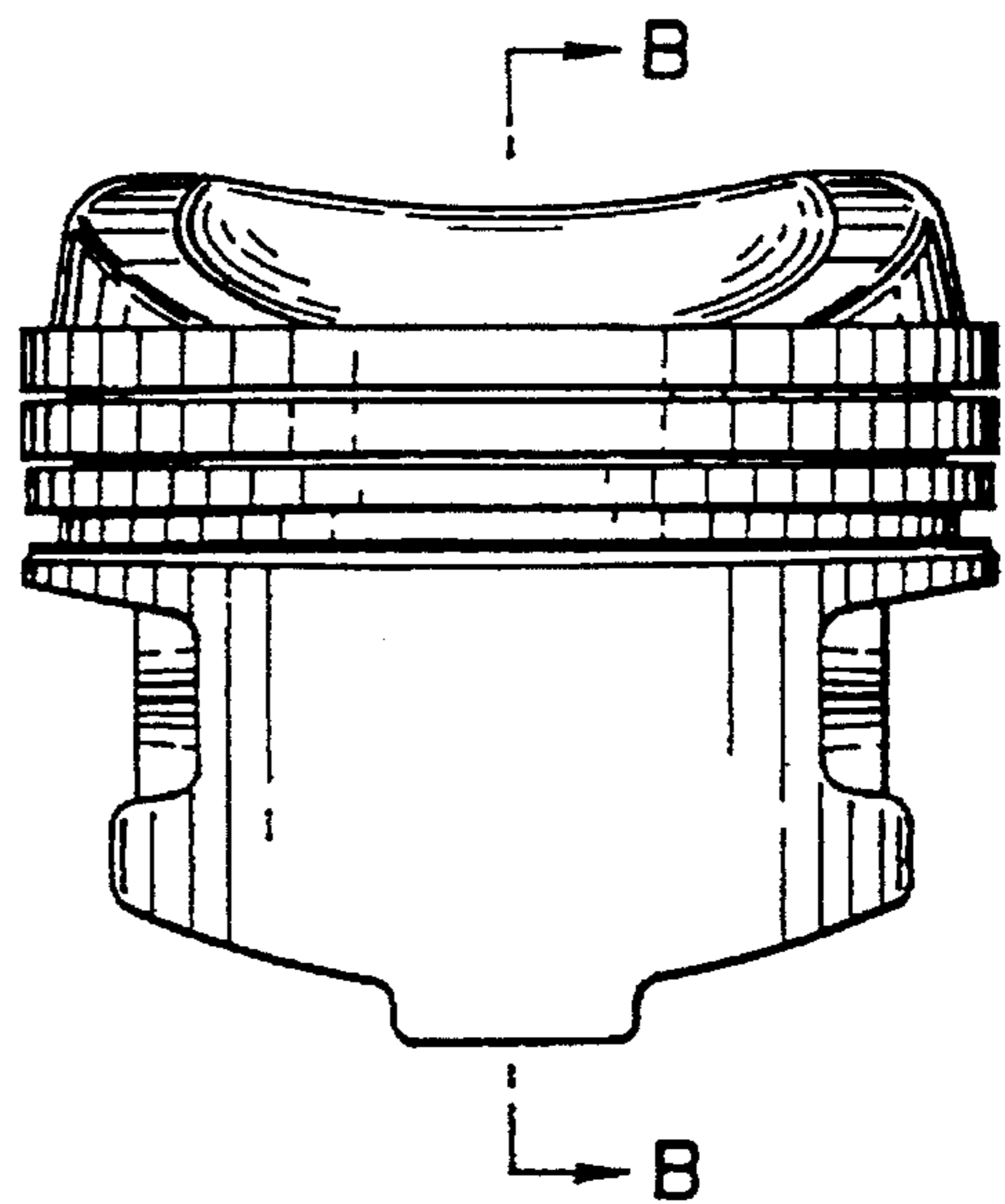

FIG. 26

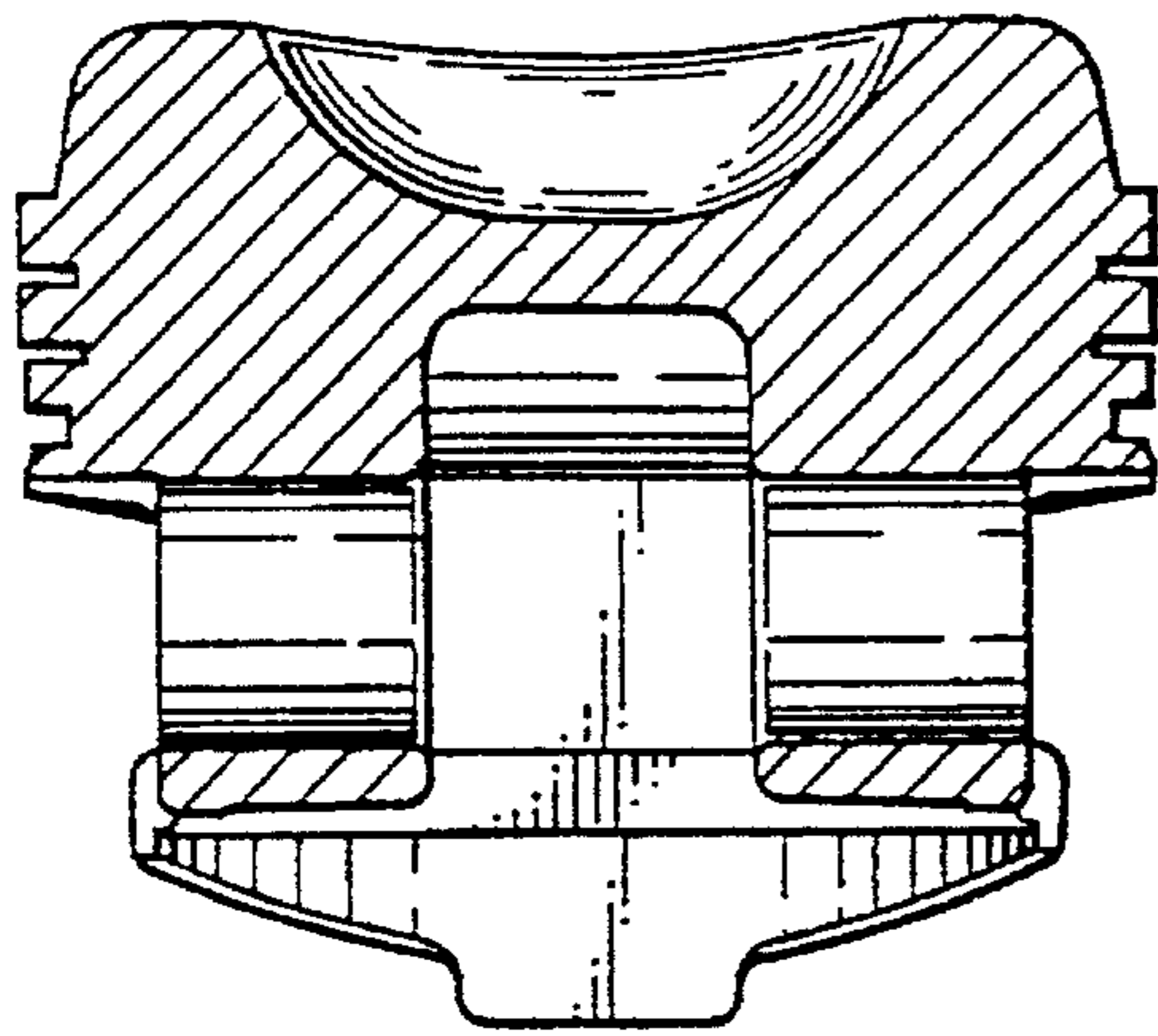

FIG. 27

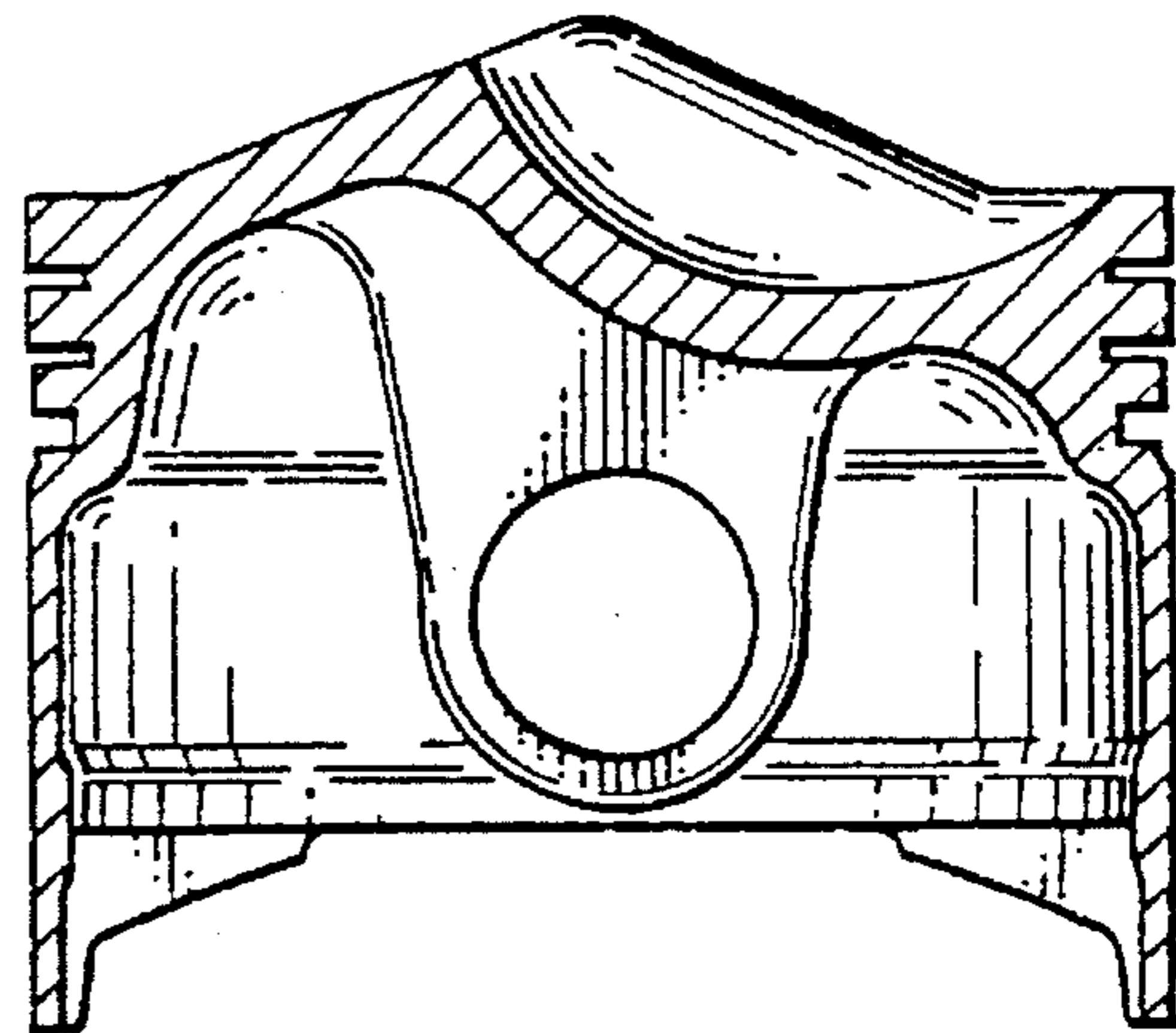

FIG. 28

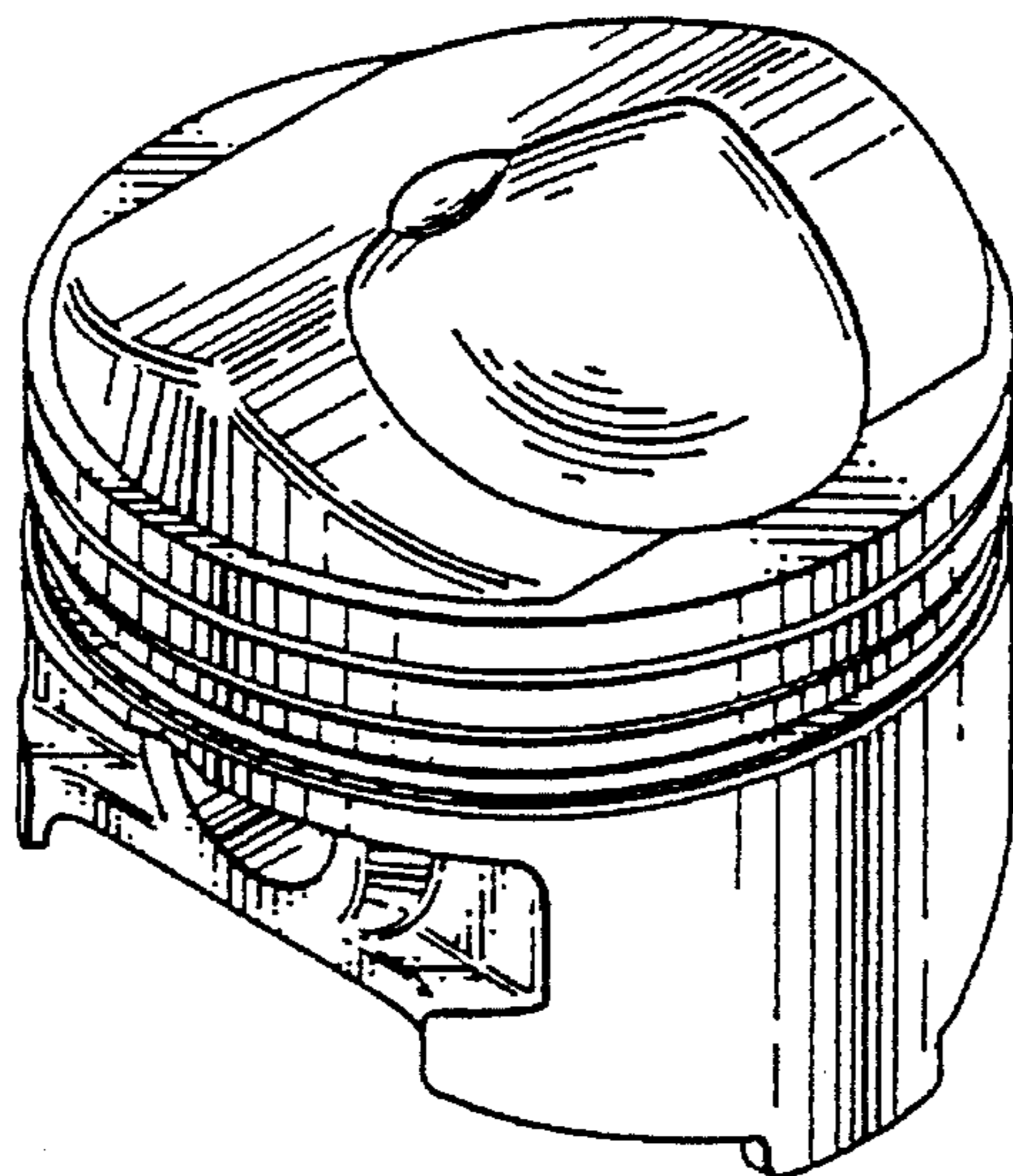

FIG. 29

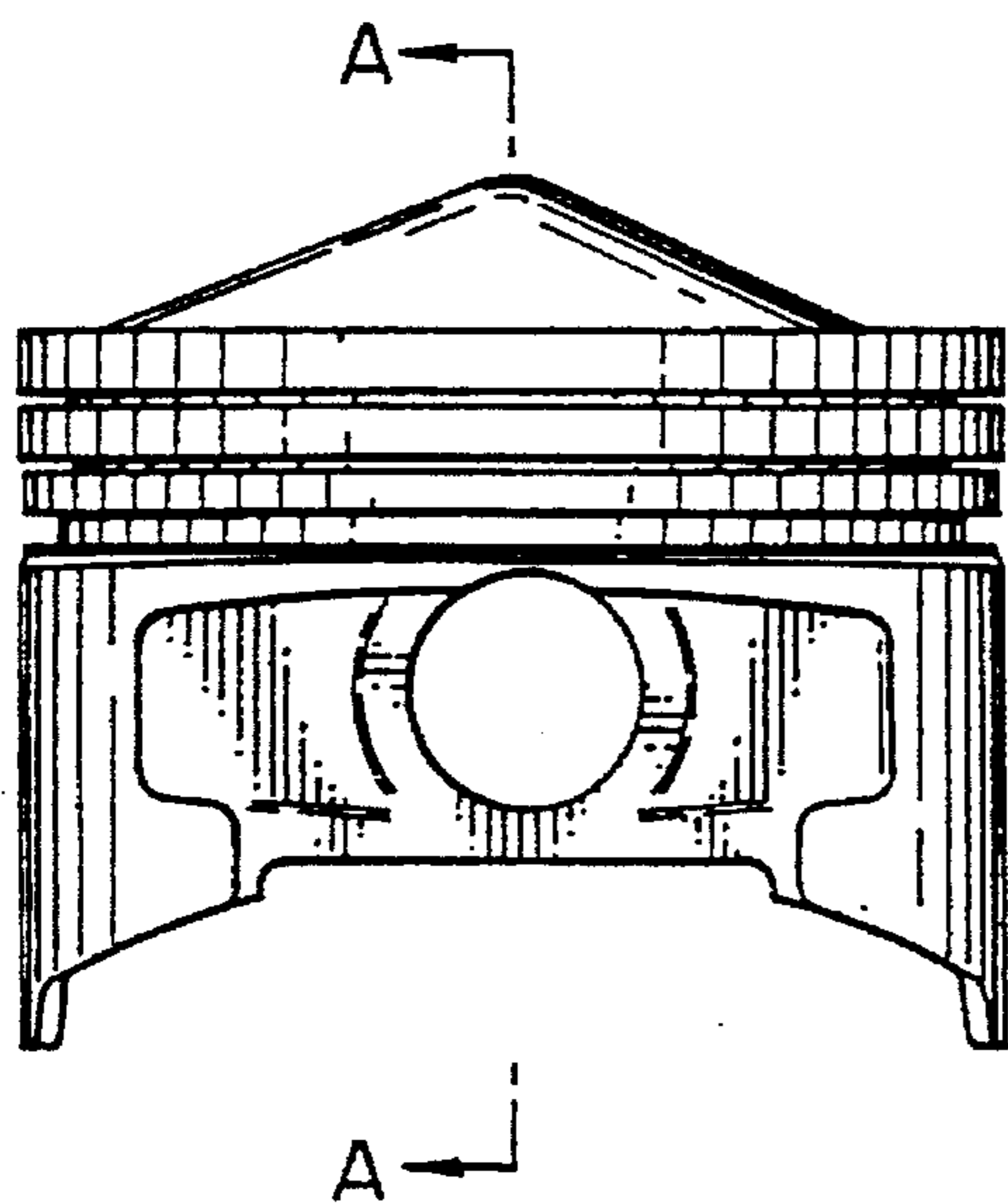

FIG. 30

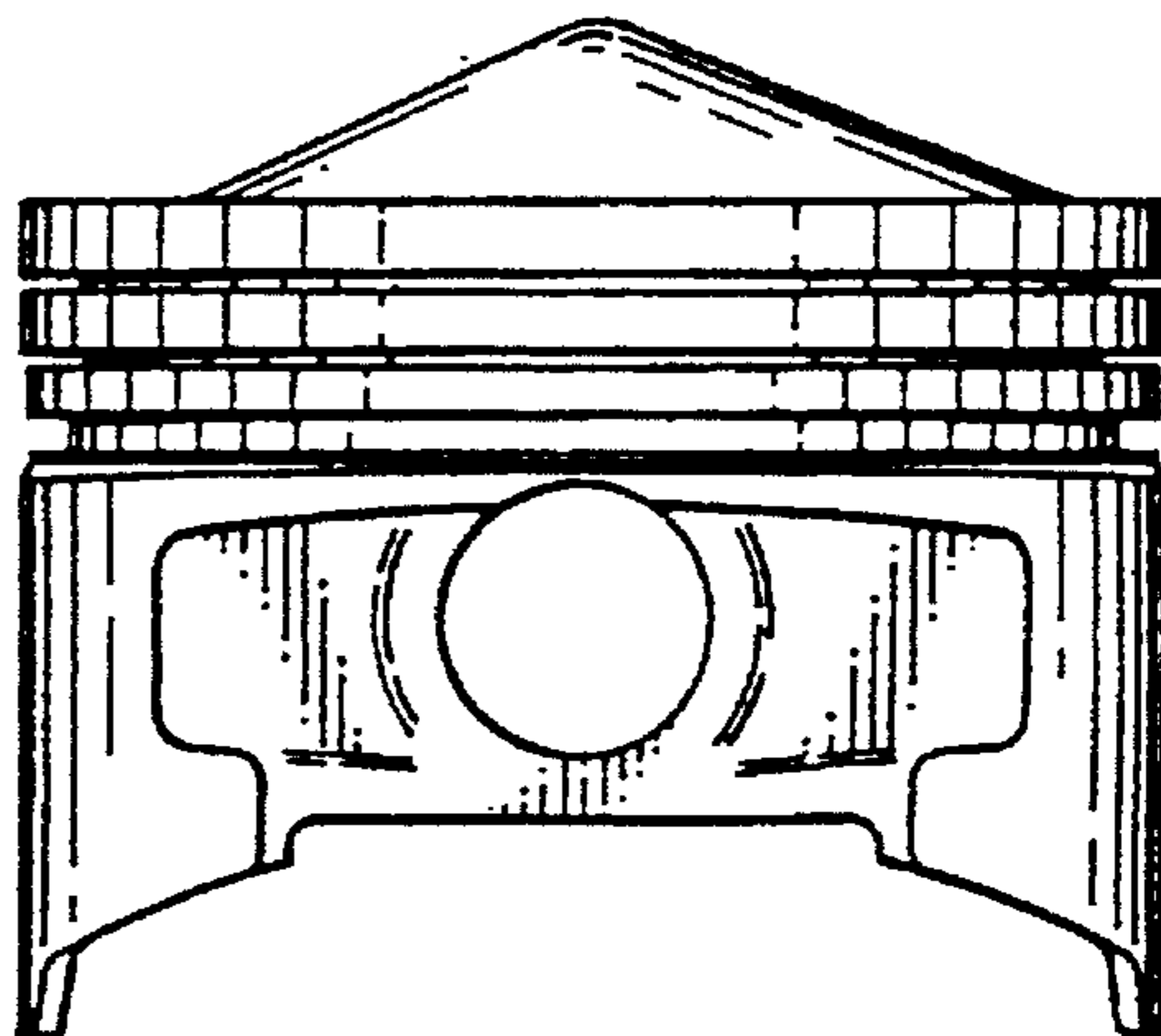

FIG. 31

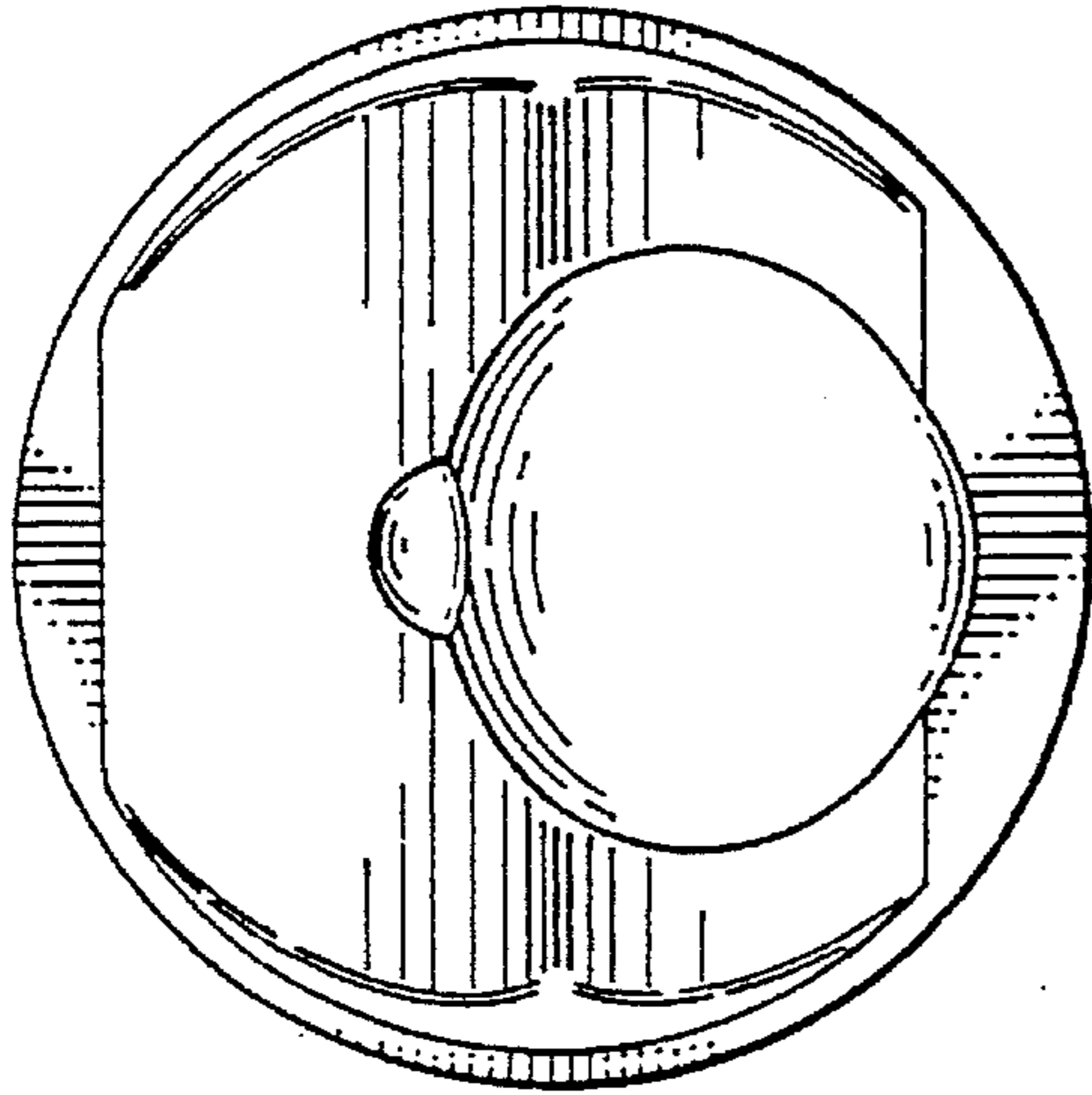

FIG. 32

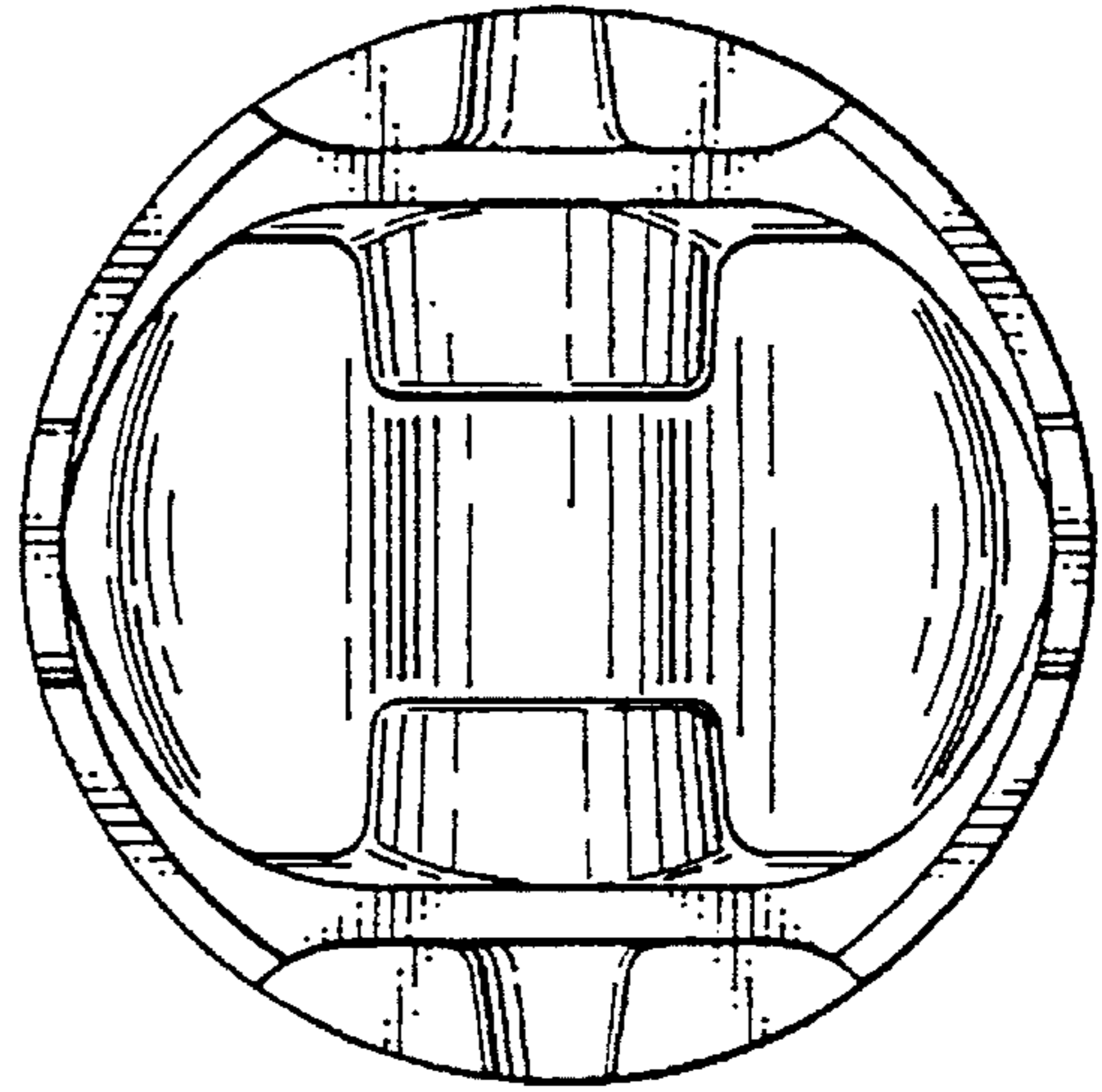

FIG. 33

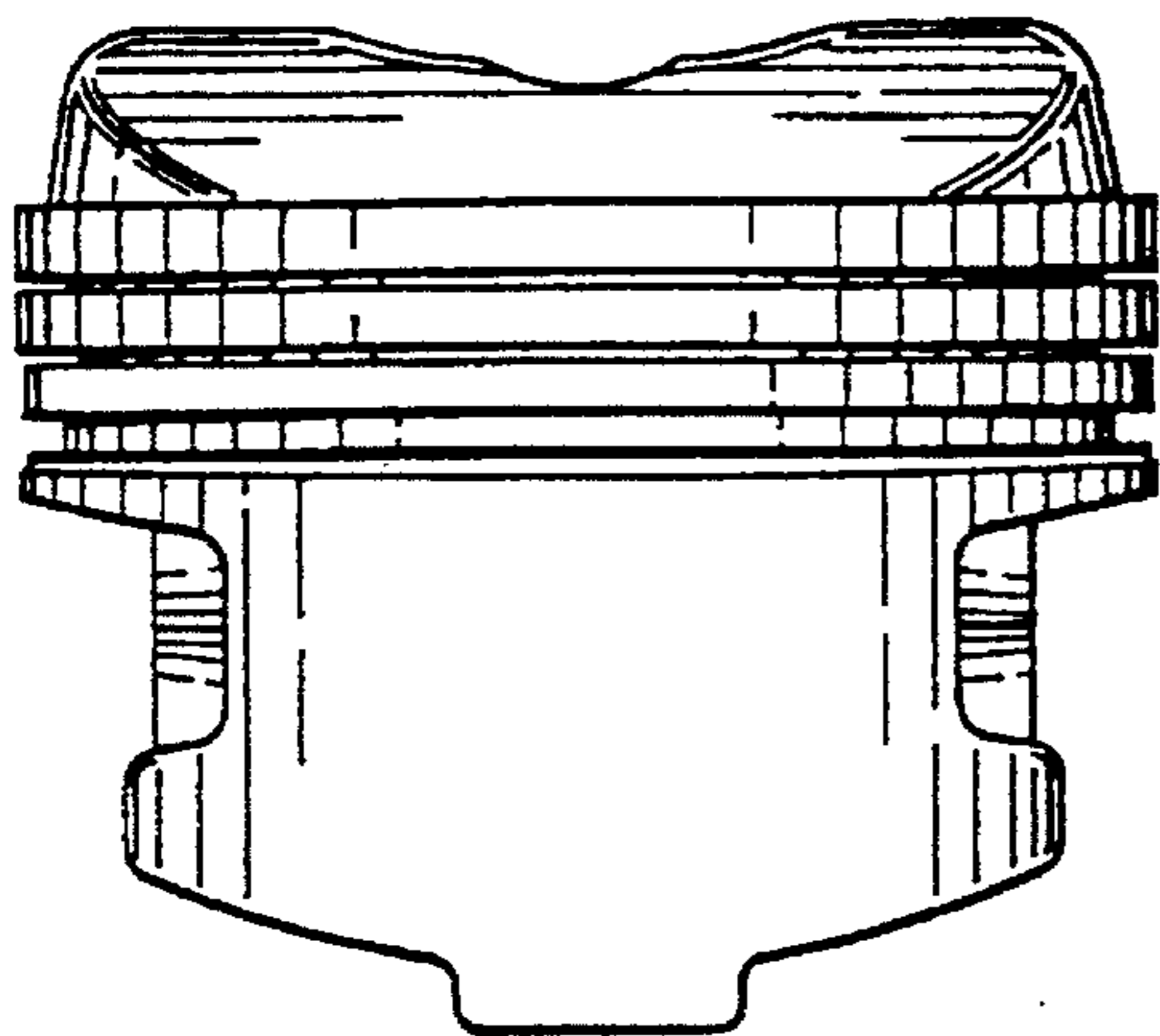

FIG. 34

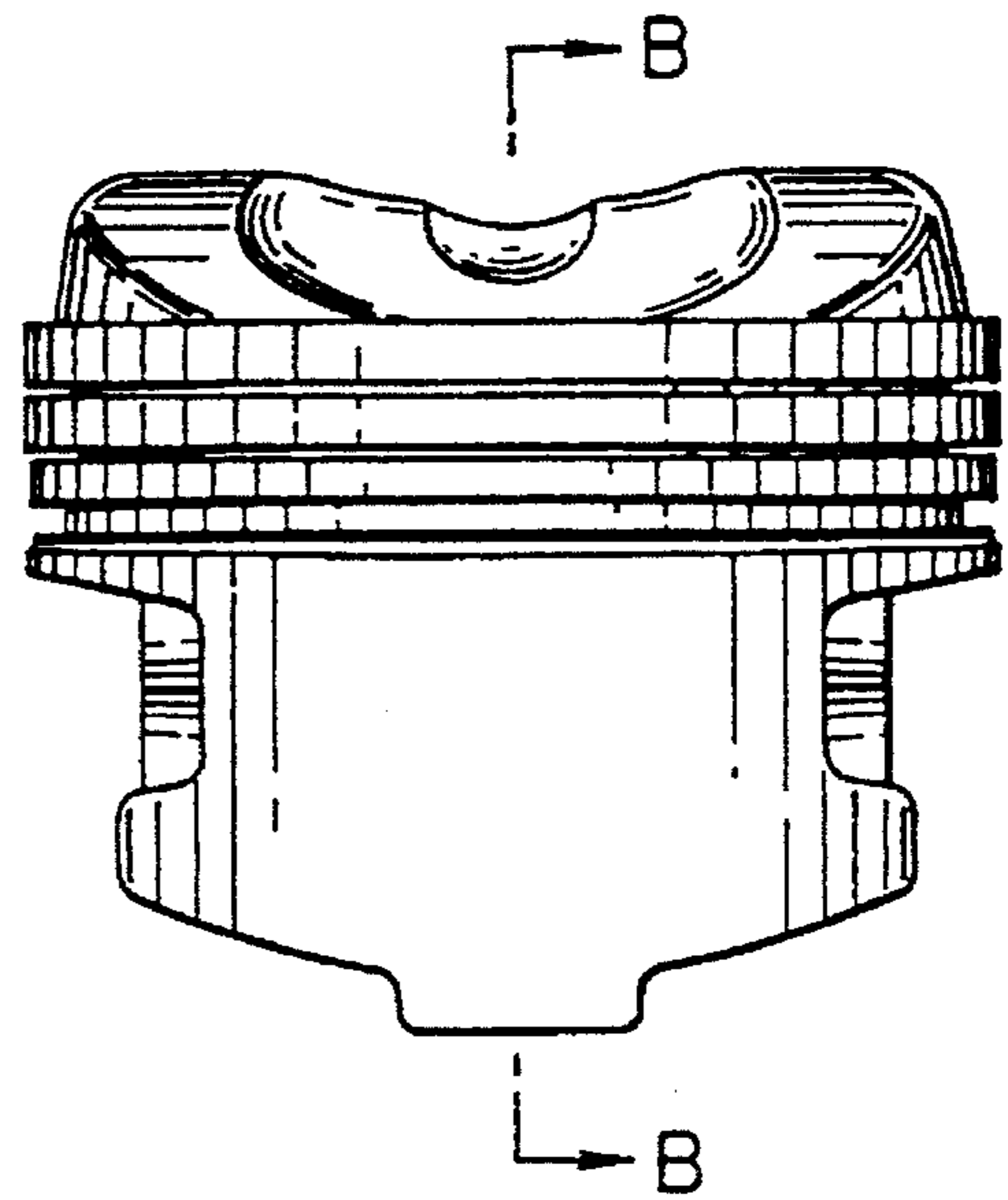

FIG. 35

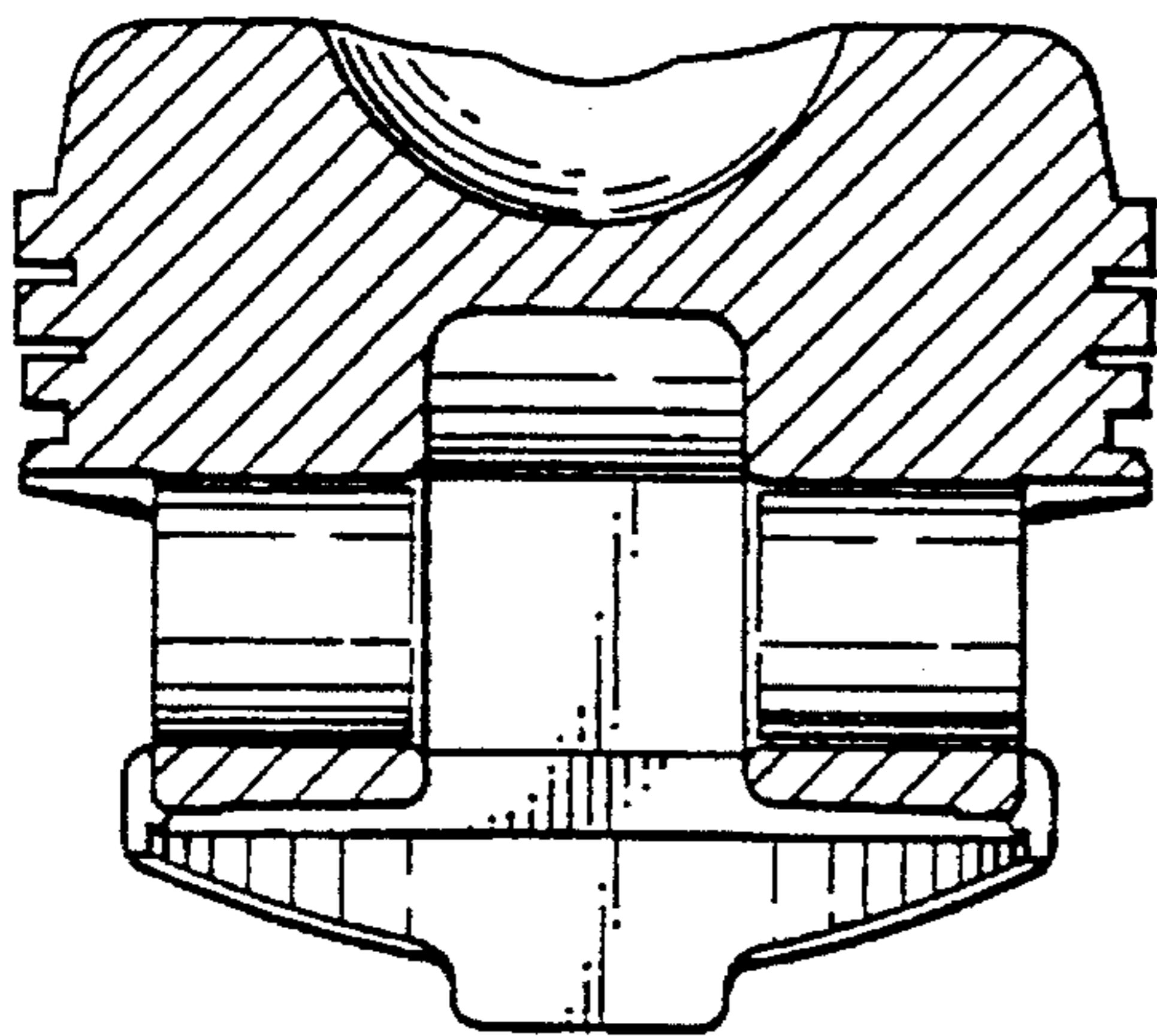

FIG. 36

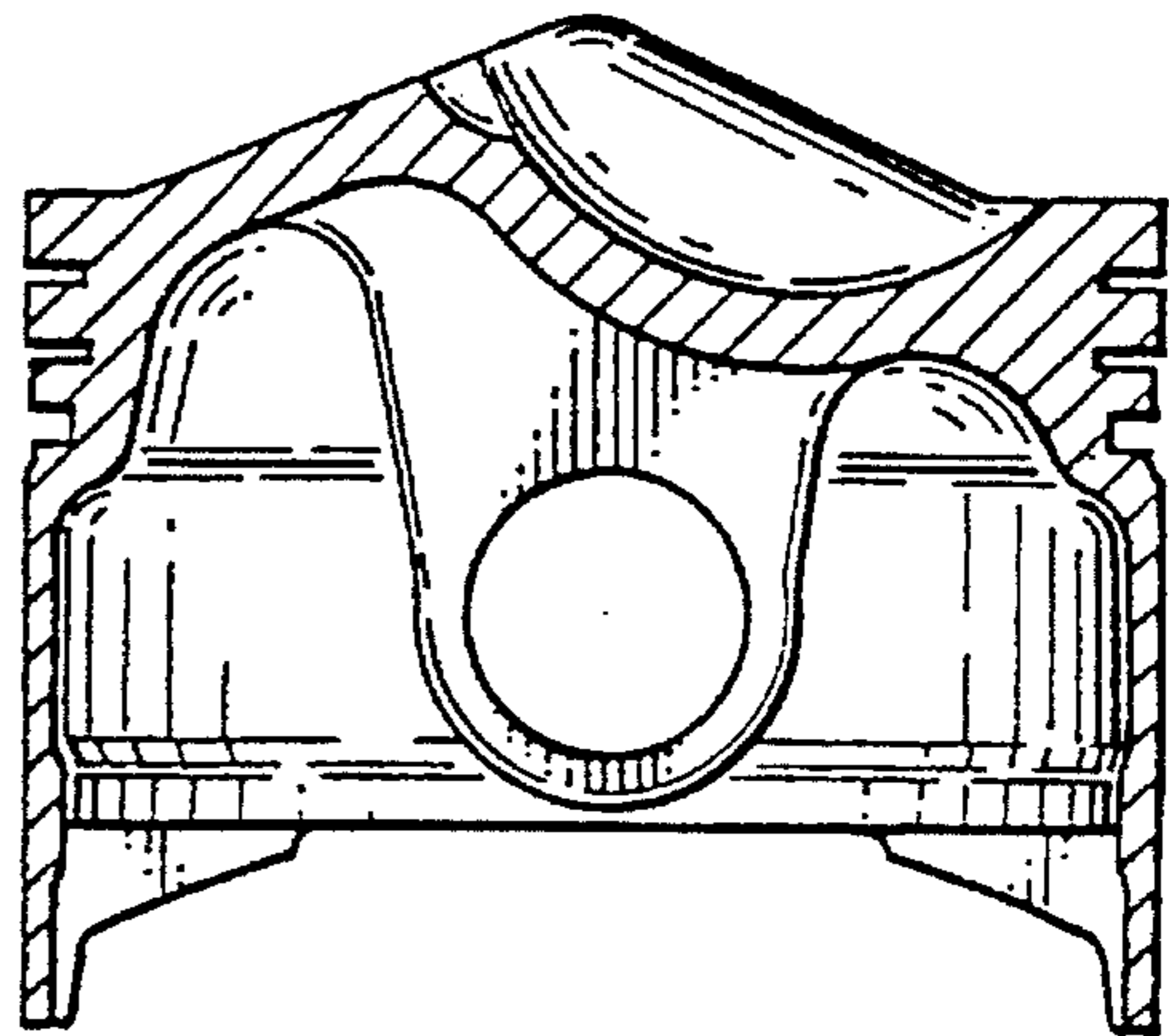

FIG. 37

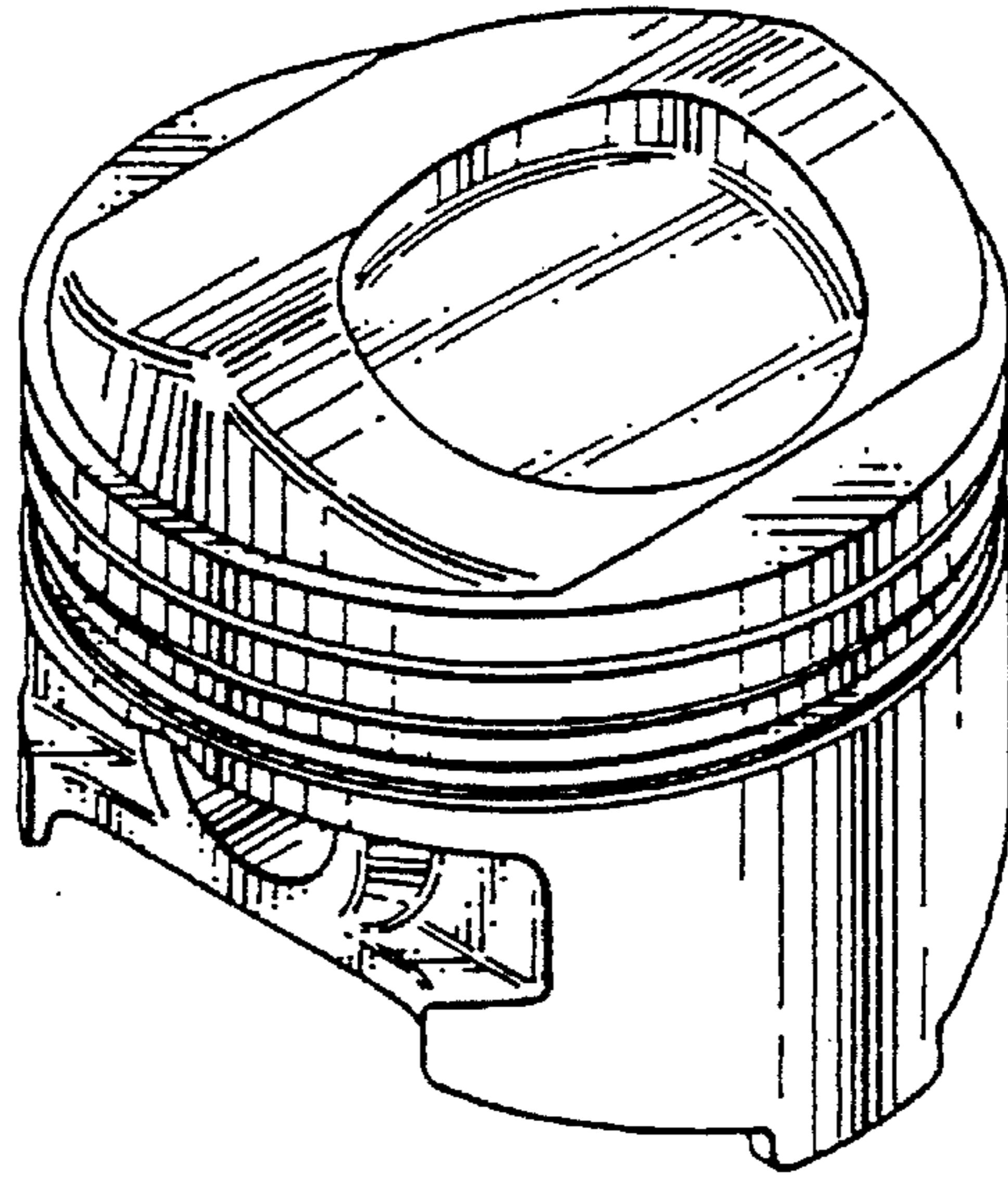

FIG. 38

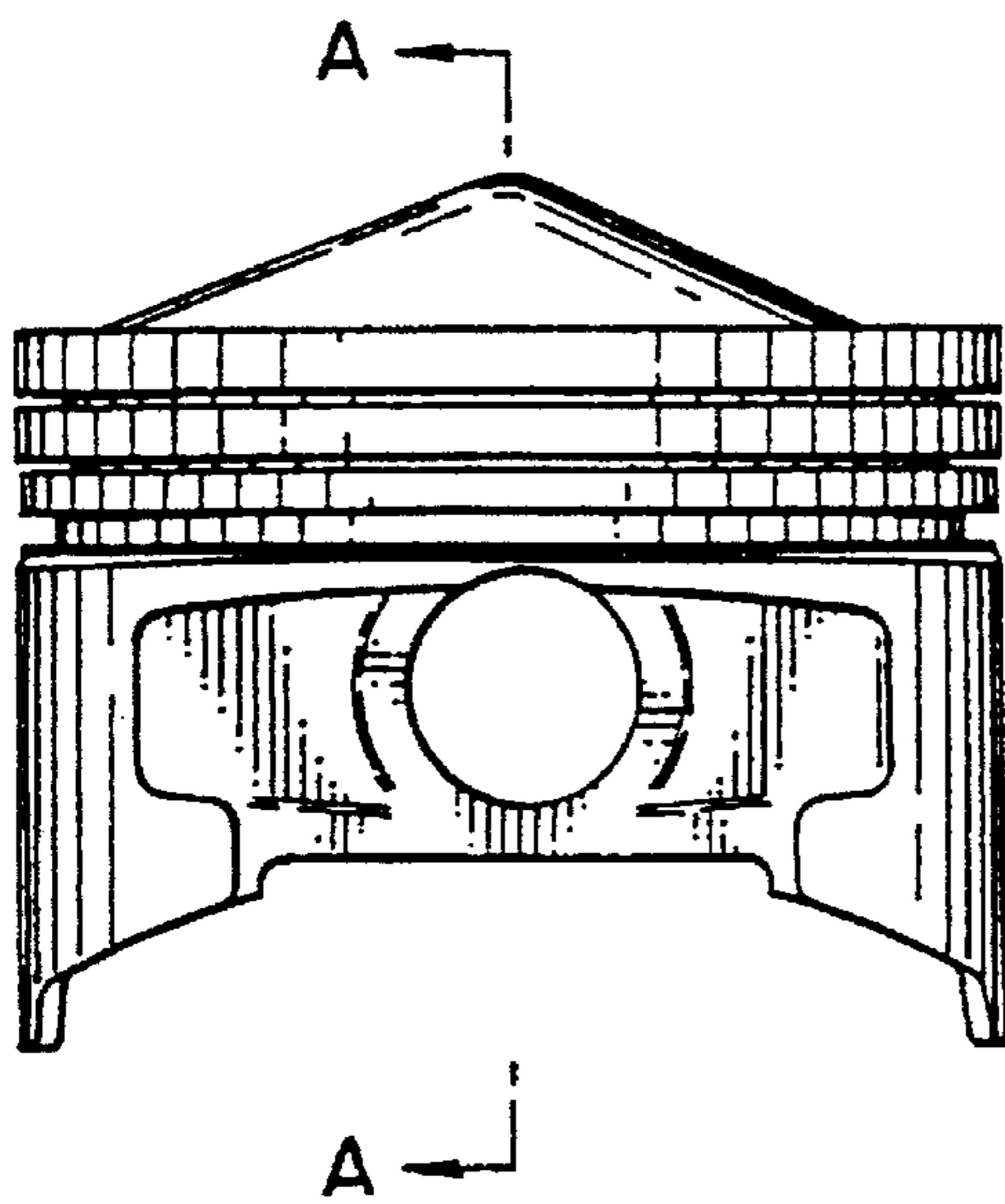

FIG. 39

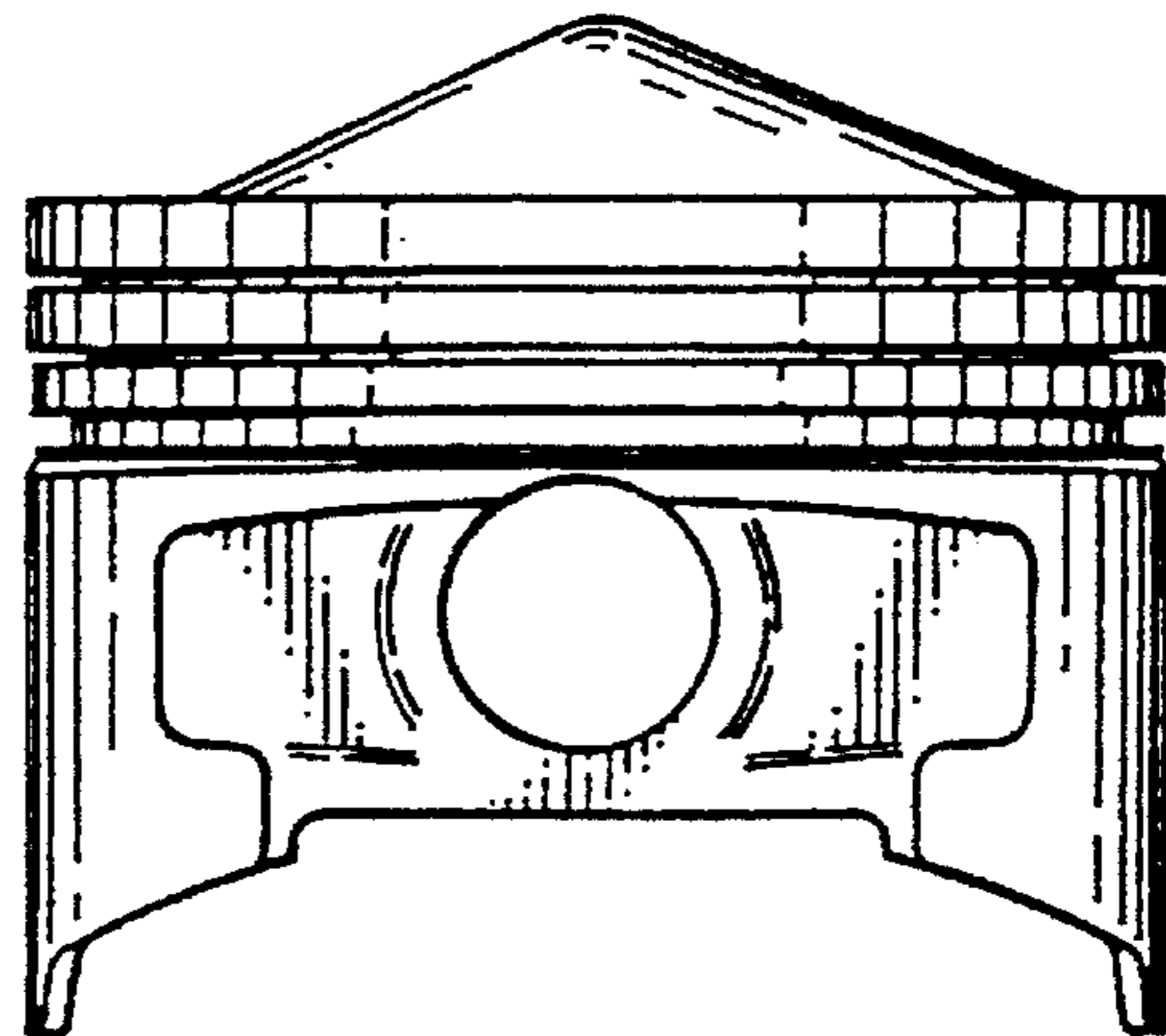

FIG. 40

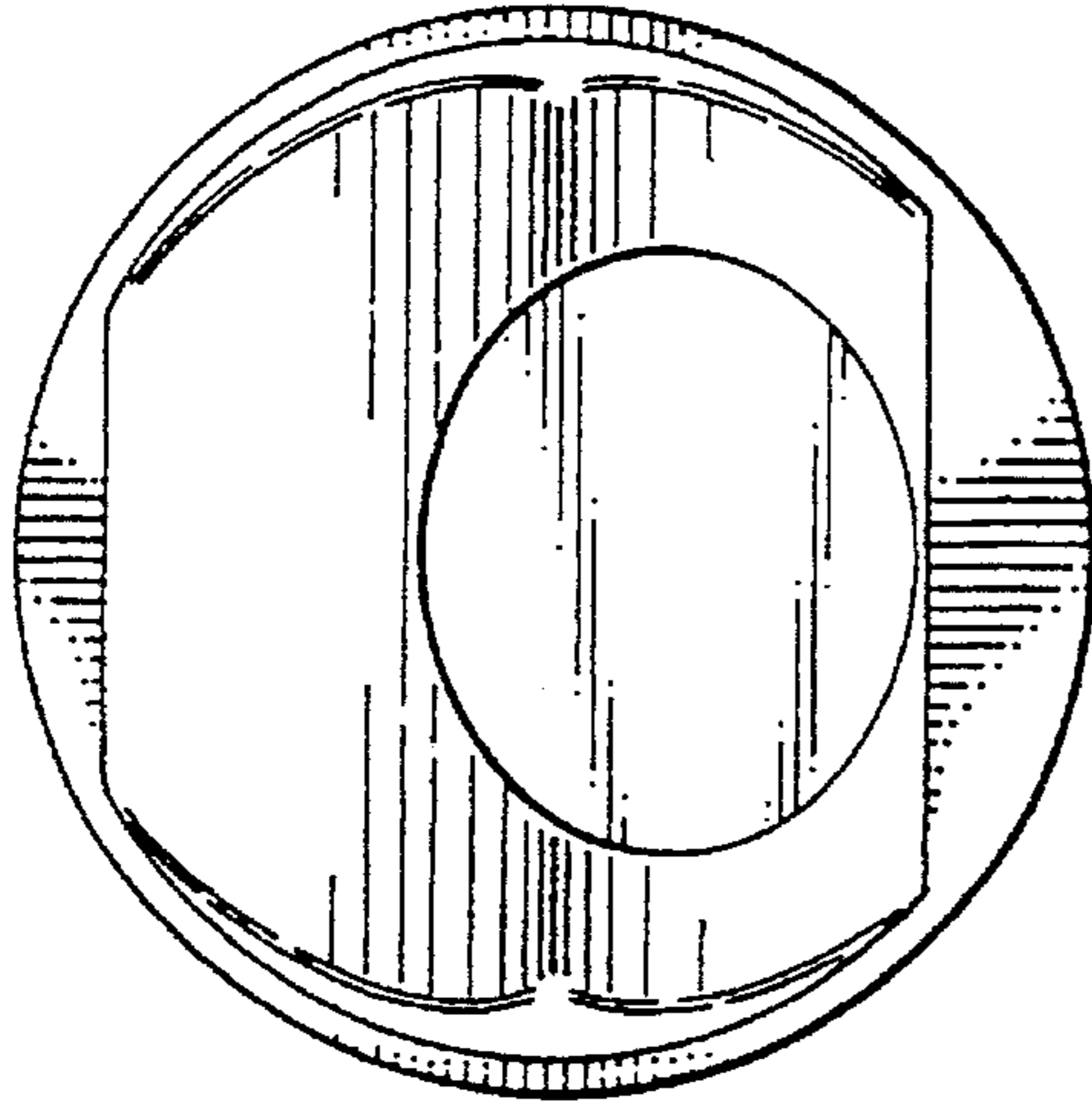

FIG. 41

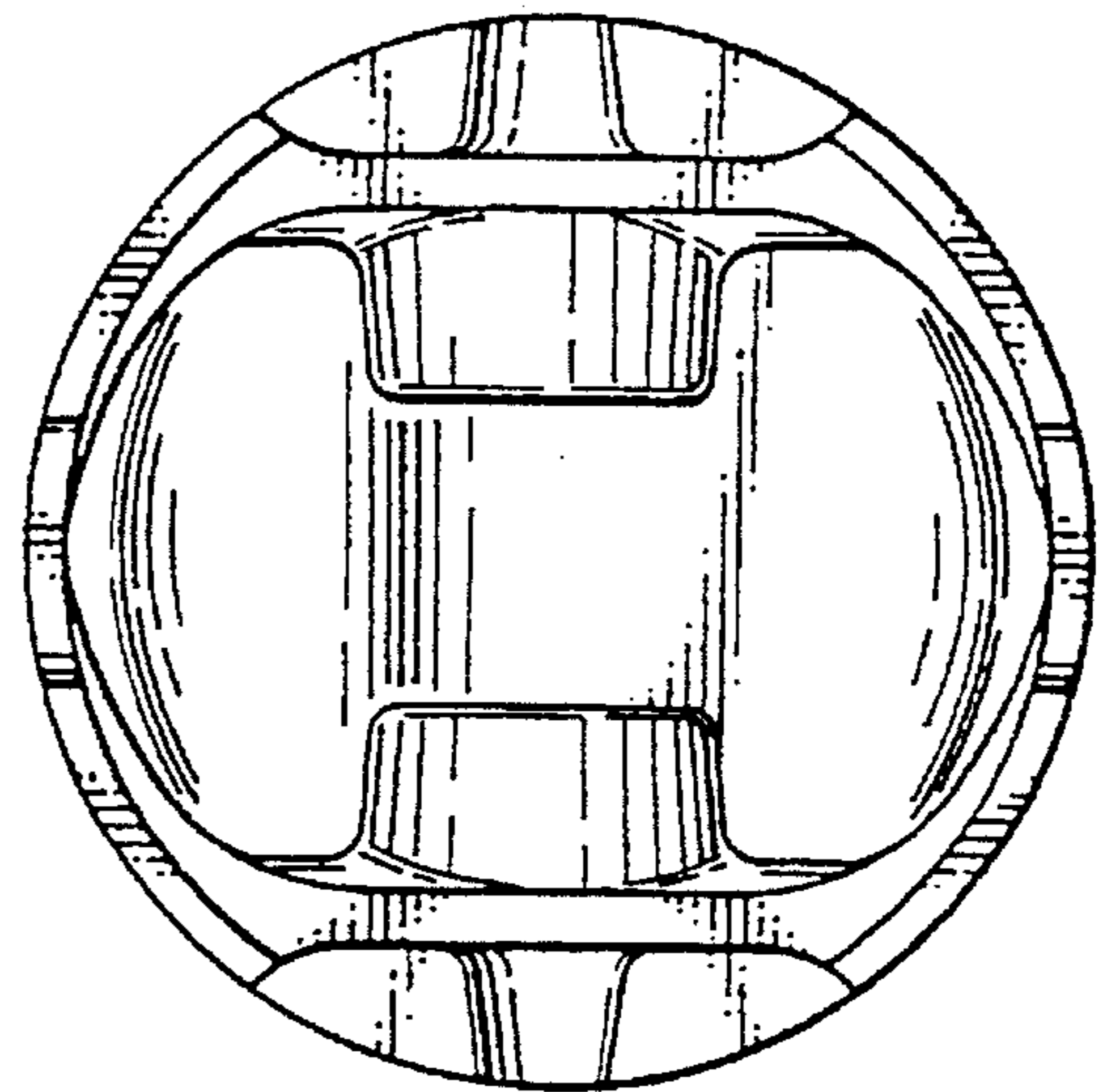

FIG. 42

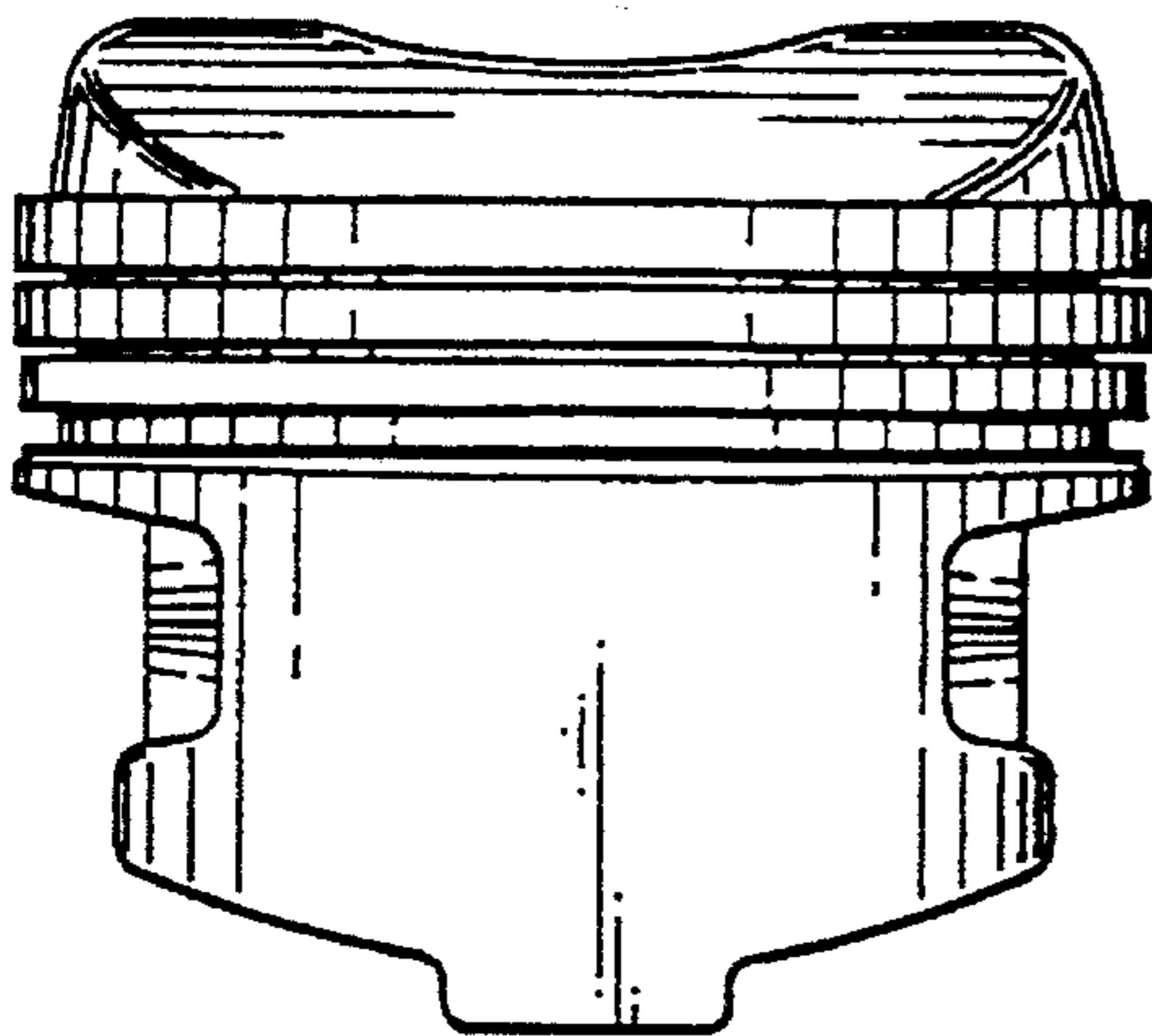

FIG. 43

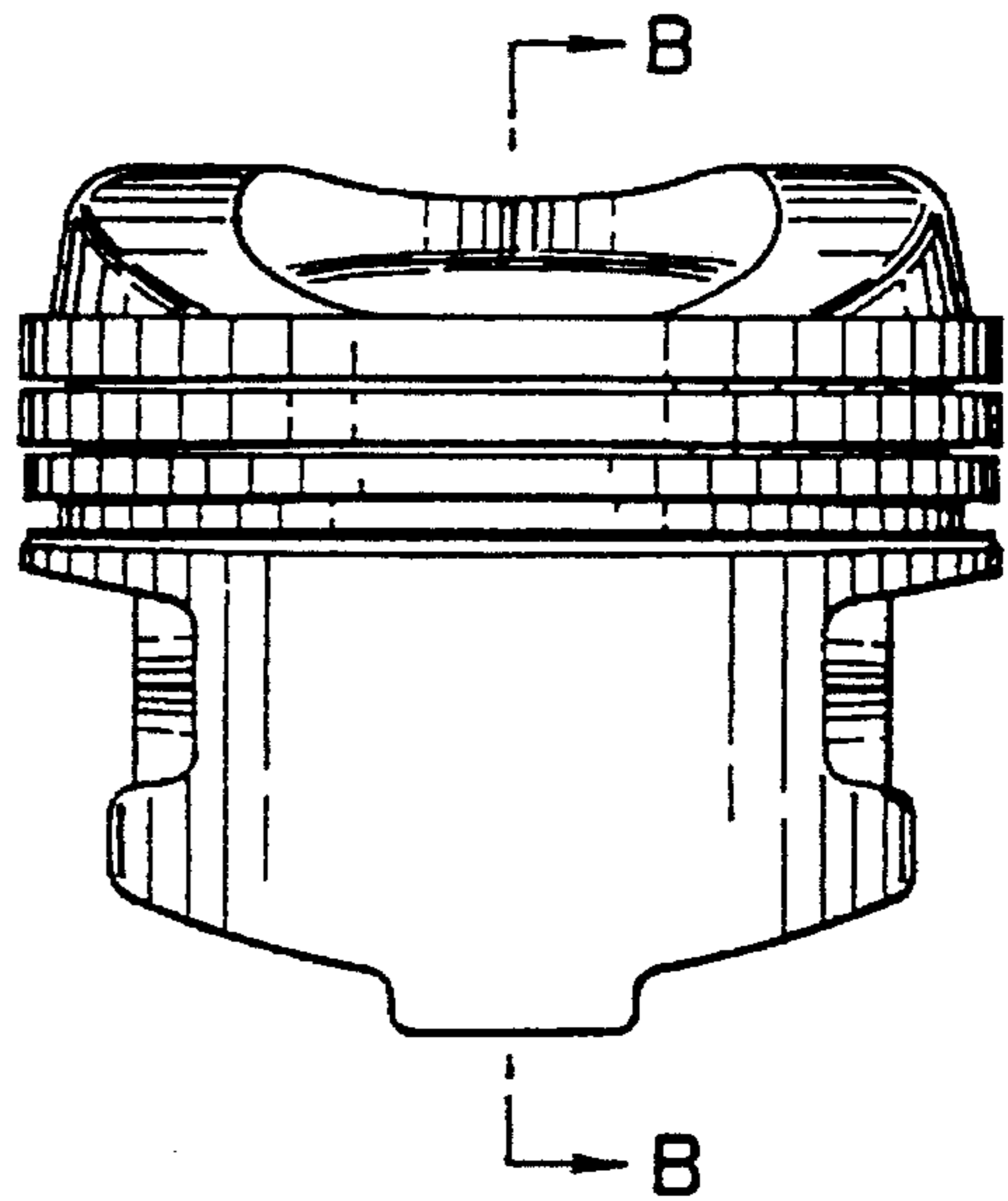



FIG. 44

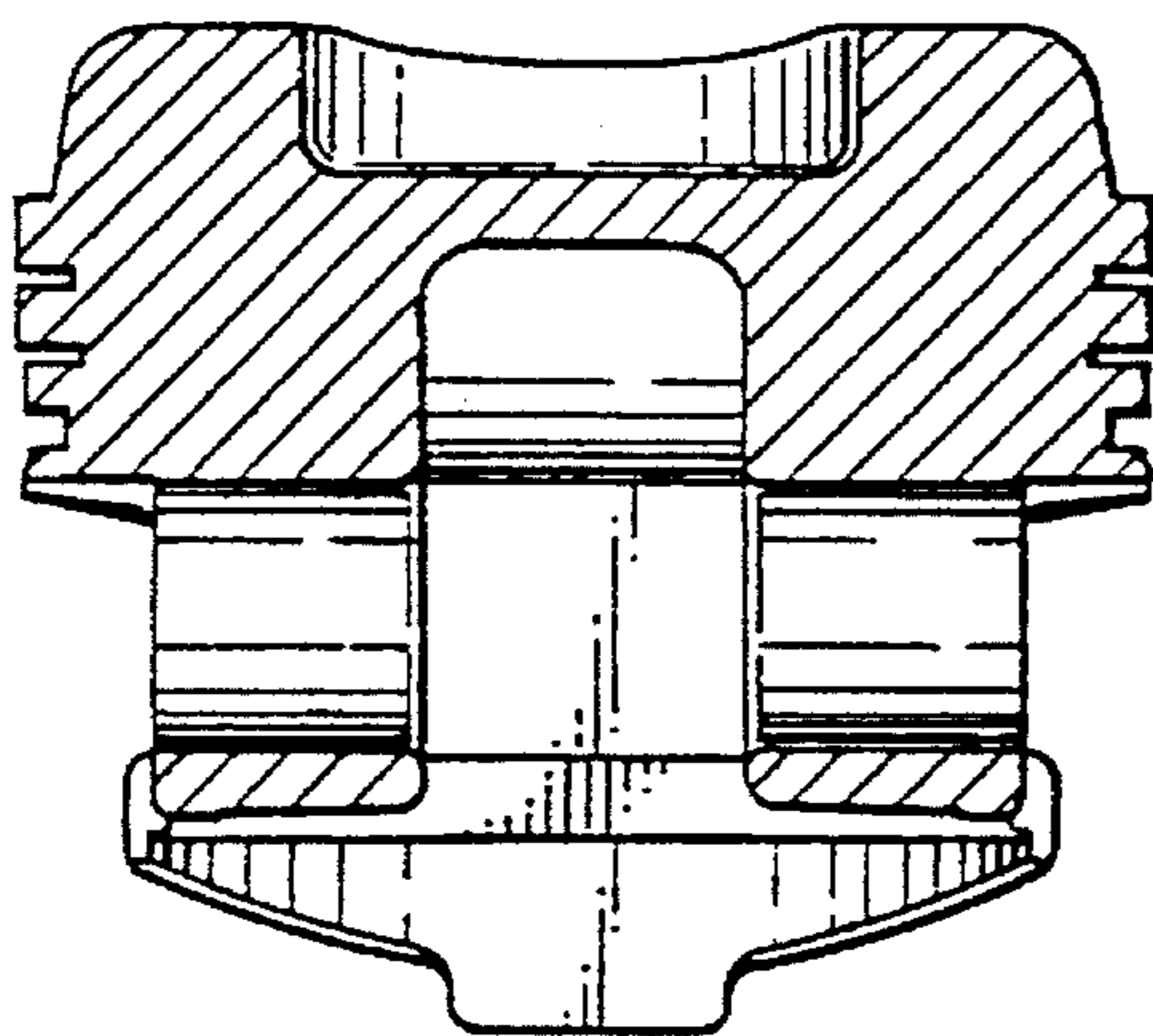

FIG. 45

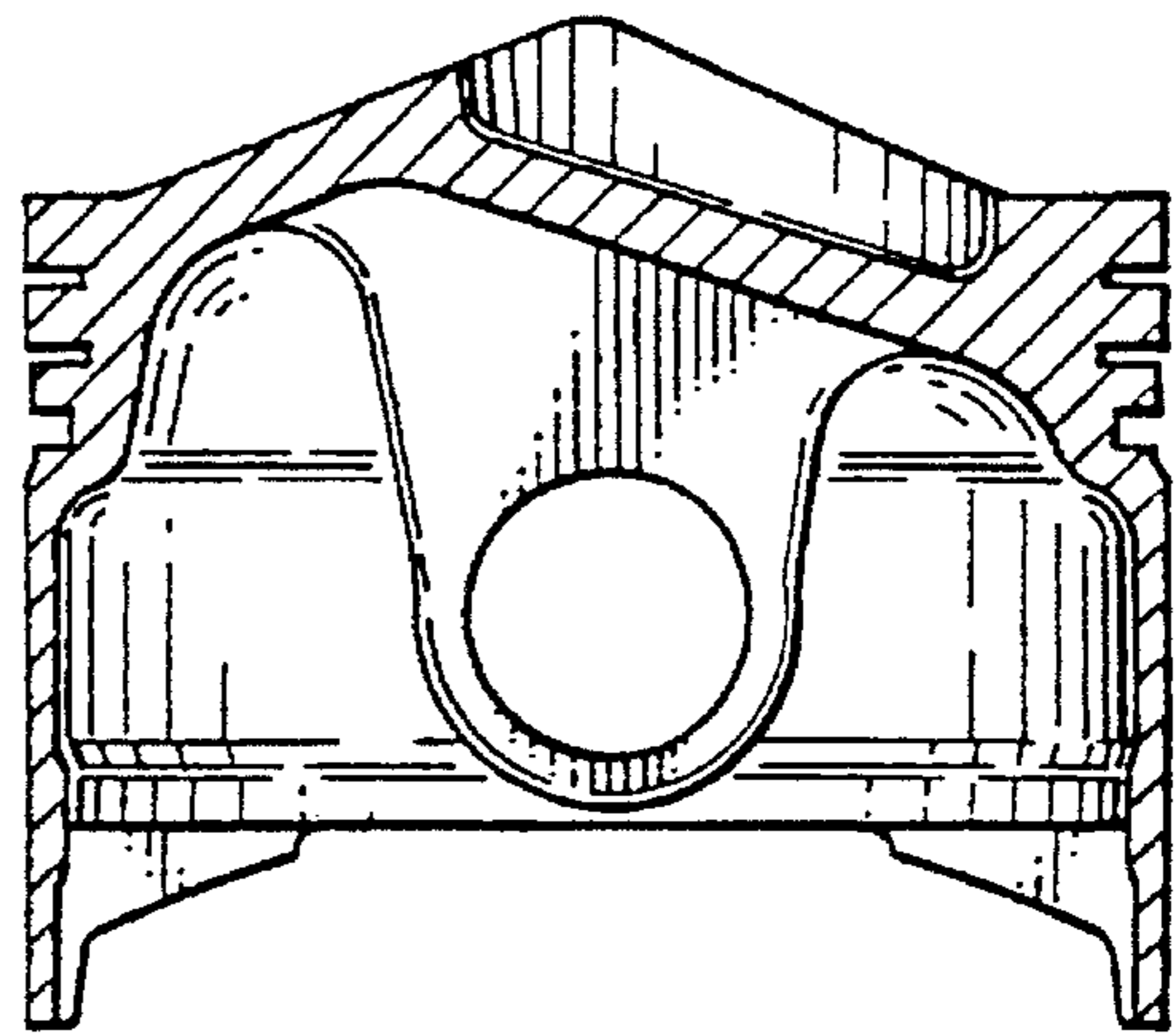

FIG. 46

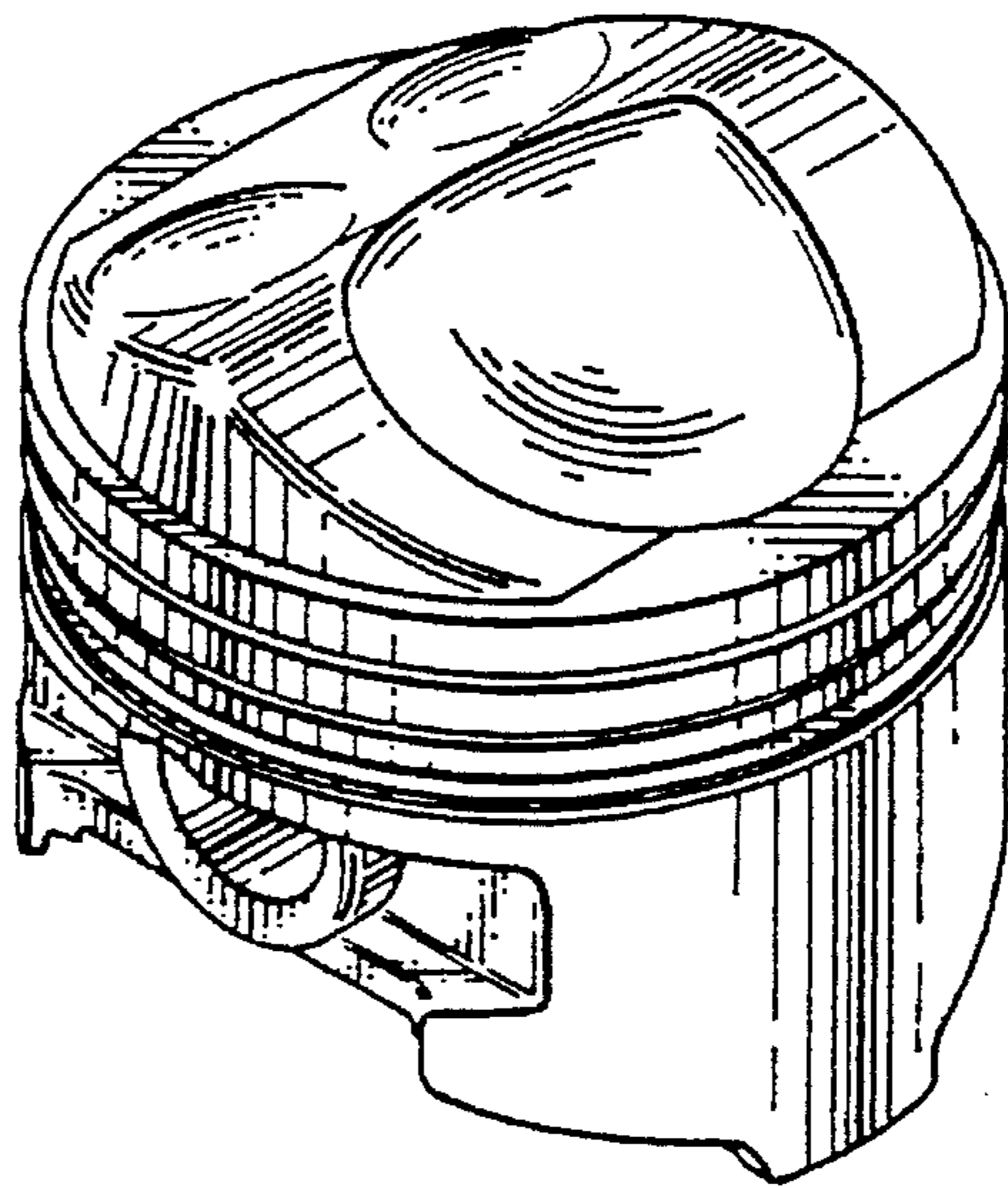

FIG. 47

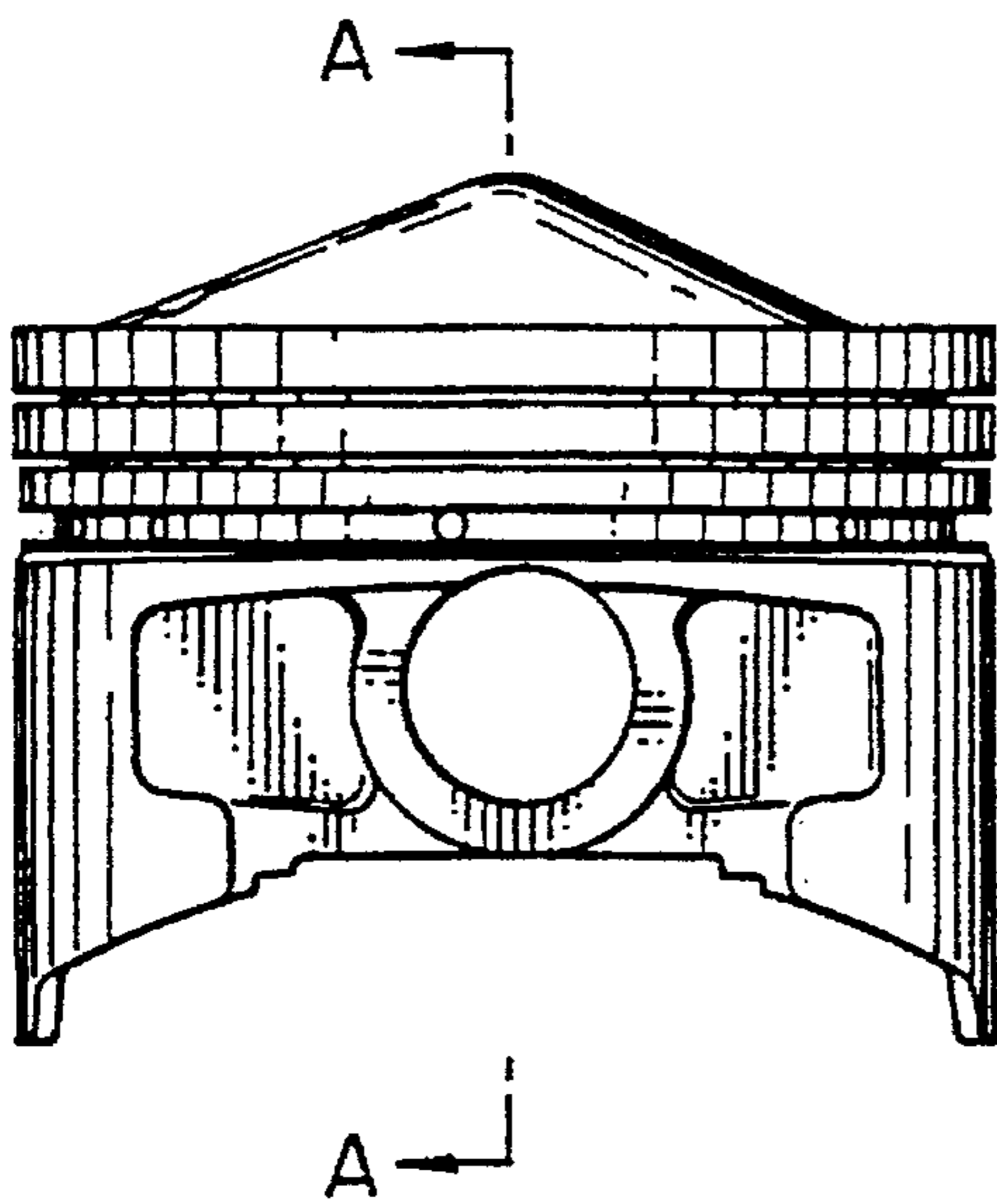

FIG. 48

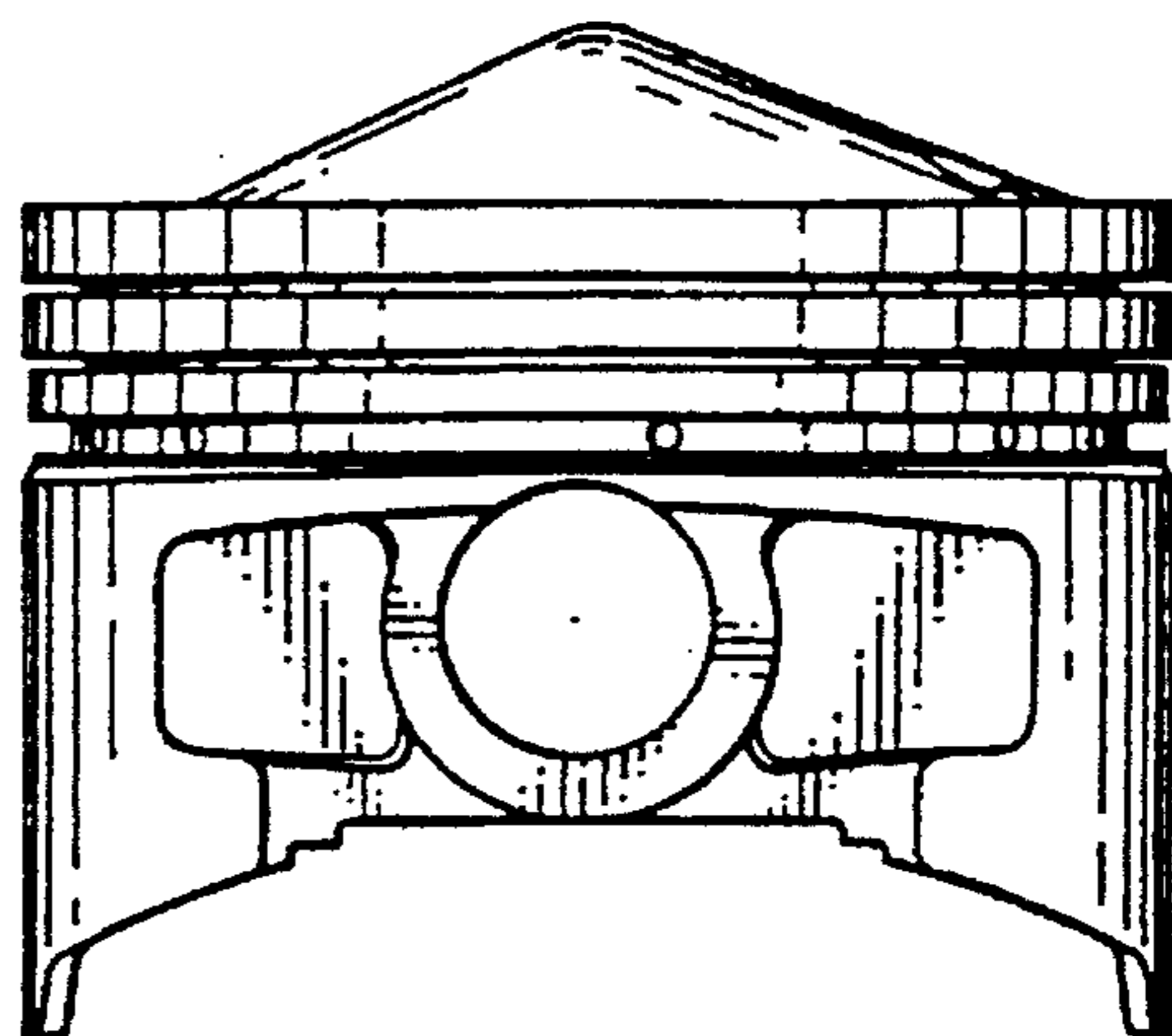

FIG. 49

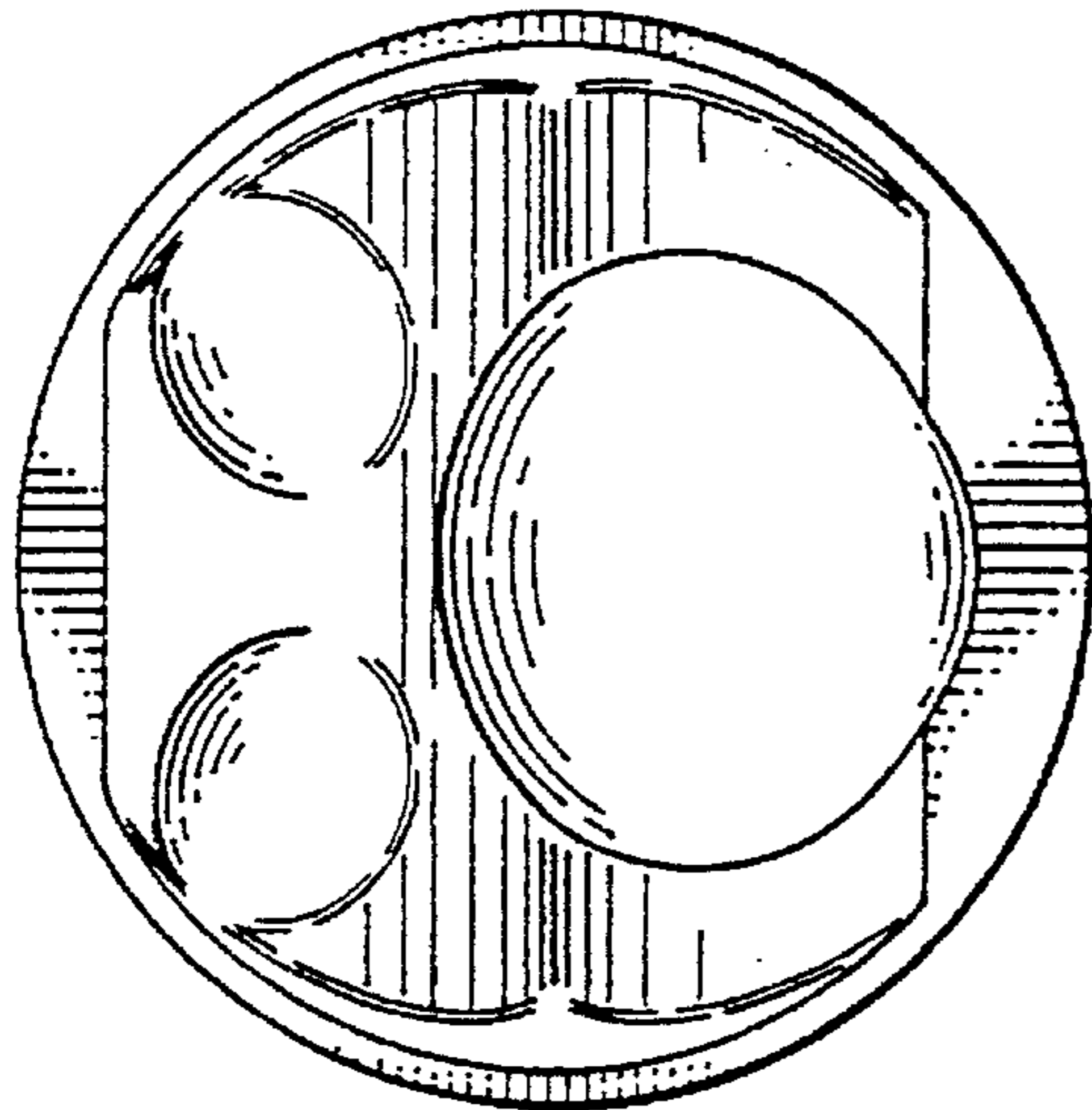

FIG. 50

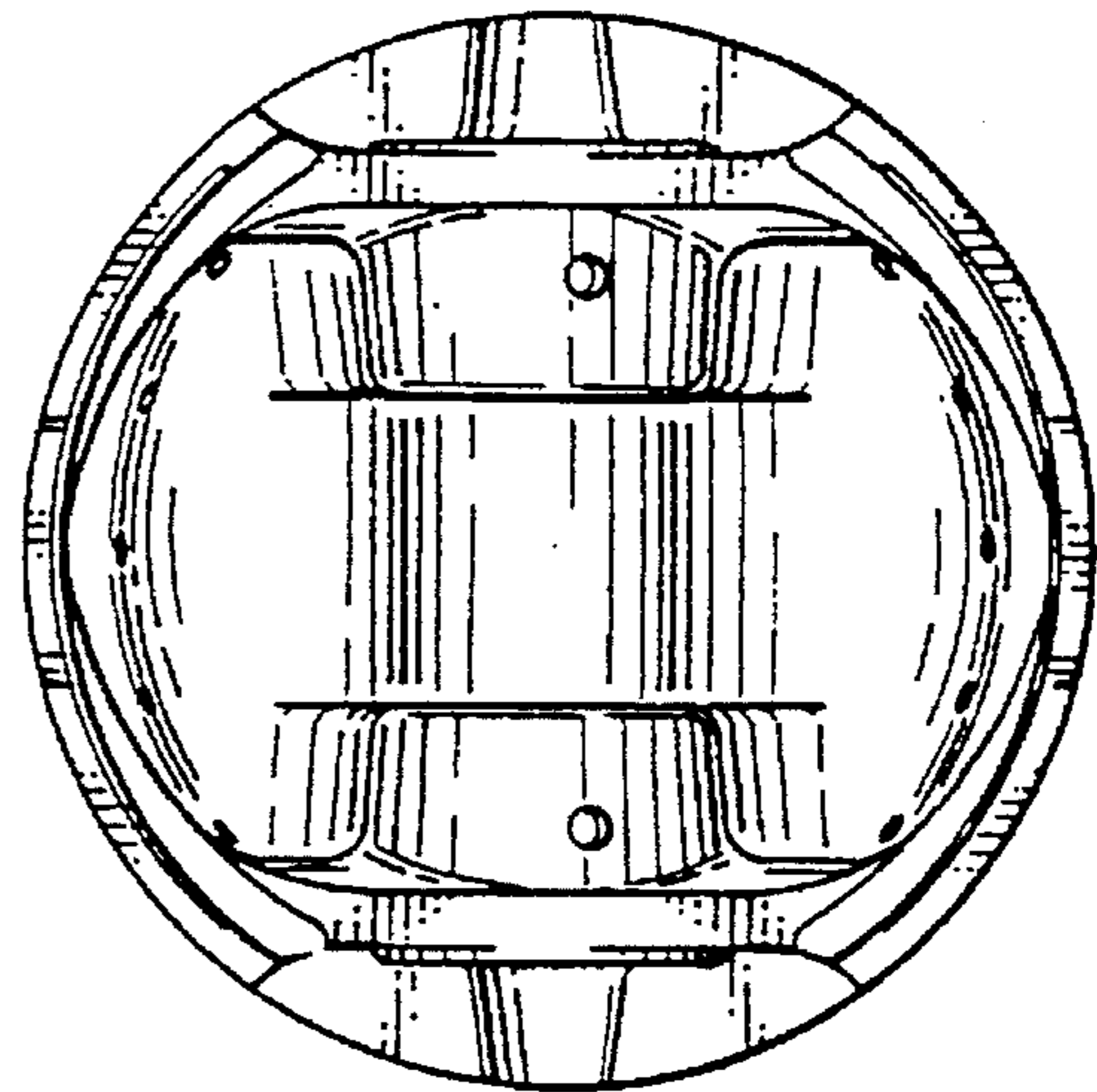

FIG. 51

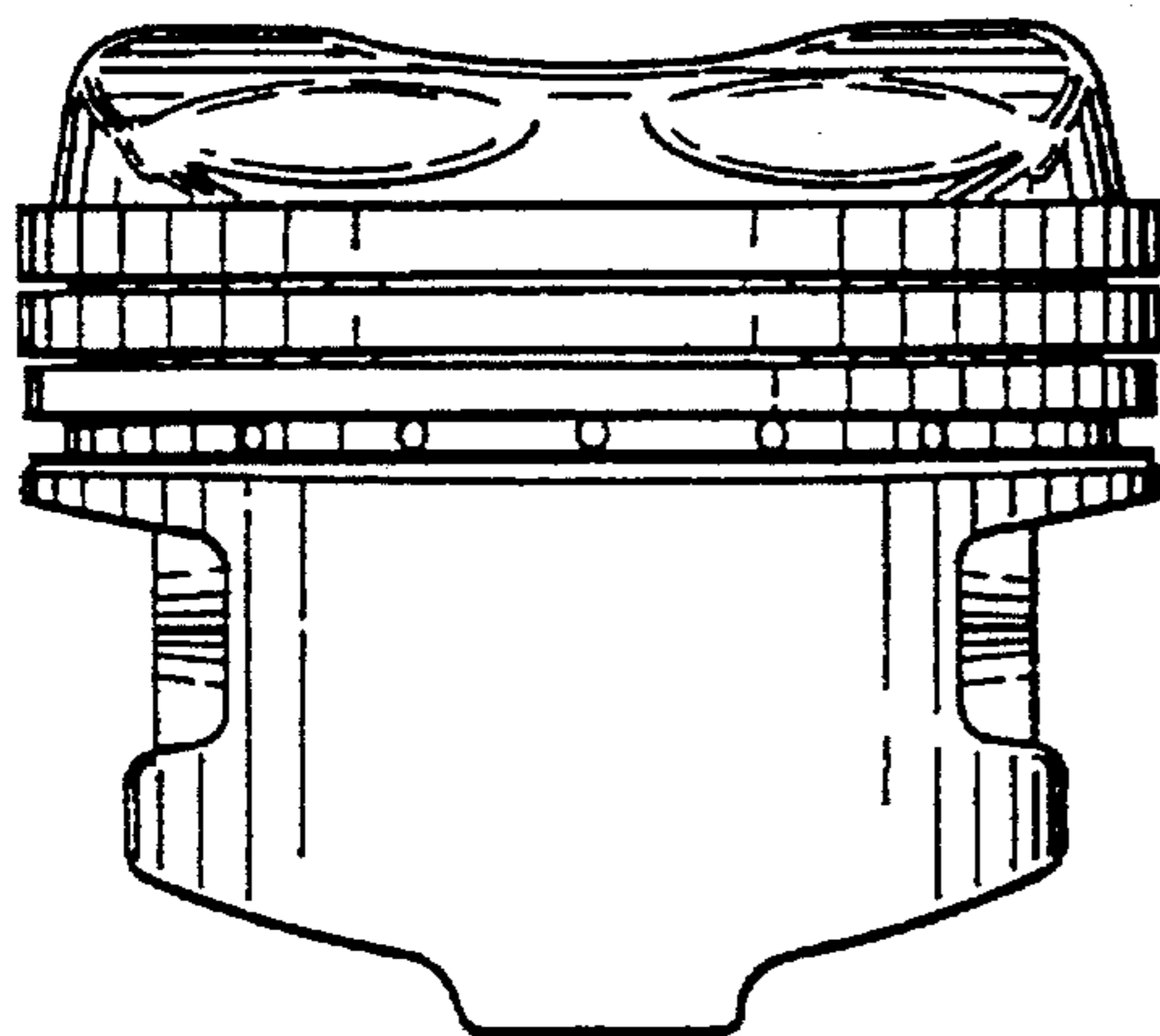

FIG. 52

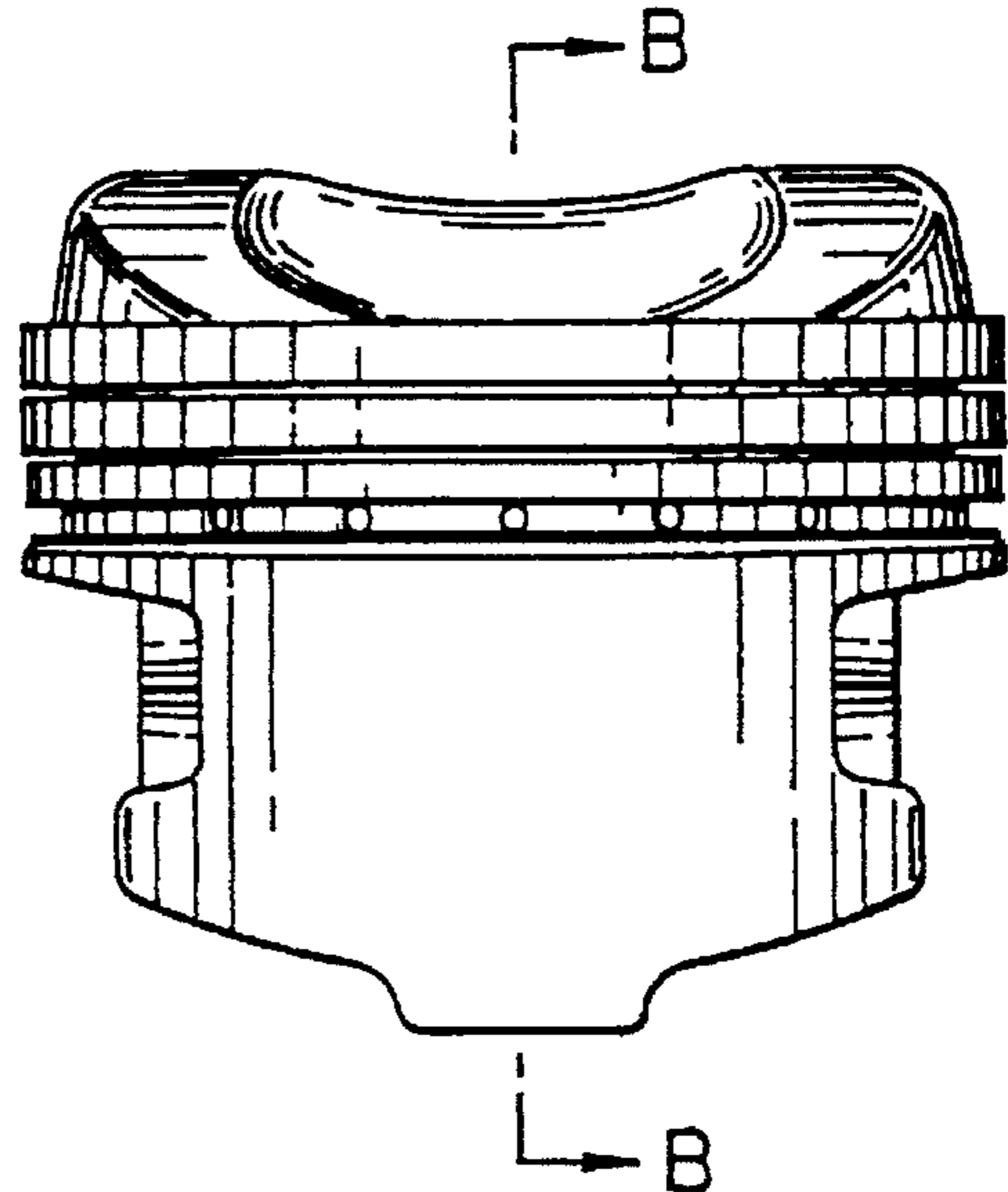

FIG. 53

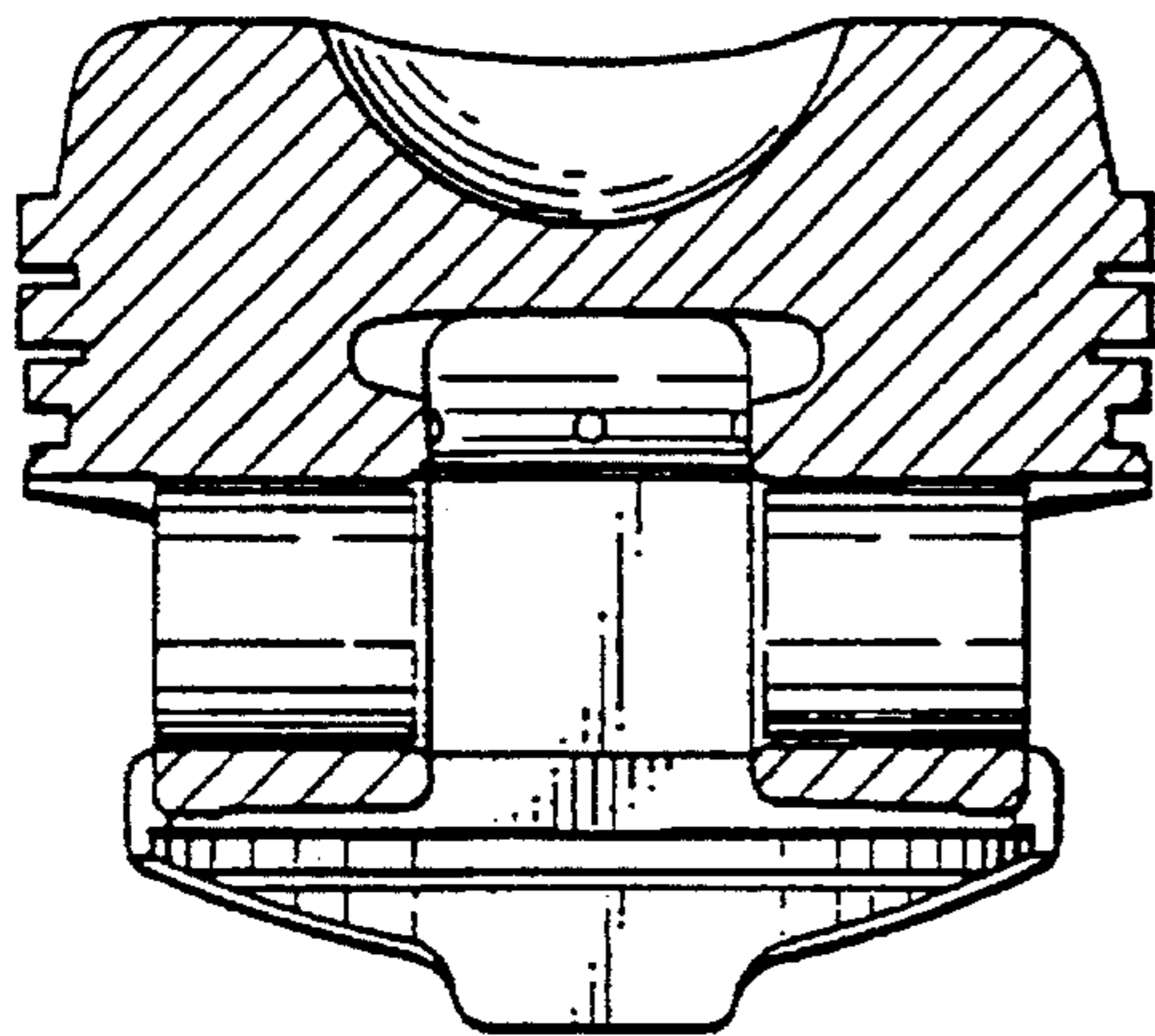

FIG. 54

