



US00D377464S

United States Patent [19]

Kciuk

[11] Patent Number: **Des. 377,464**

[45] Date of Patent: ****Jan. 21, 1997**

[54] BICYCLE FRAME

[75] Inventor: **Bernhard Kciuk**, Beilstein, Germany

[73] Assignee: **Dr. Ing. h.c.F. Porsche AG**, Weissach, Germany

[**] Term: **14 Years**

[21] Appl. No.: **50,652**

[22] Filed: **Feb. 21, 1996**

[30] Foreign Application Priority Data

Sep. 2, 1995 [DE] Germany M 95 06 944.5

[52] U.S. Cl. **D12/111**

[58] Field of Search D12/111; 280/281.1, 280/288.1-288.3, 283, 284, 275

[56] References Cited

U.S. PATENT DOCUMENTS

D. 321,156	10/1991	Browning	D12/111
D. 331,376	12/1992	Sewell	D12/111
D. 368,678	4/1996	Wilcox et al.	D12/111
D. 370,436	6/1996	Warren et al.	D12/111
5,240,268	8/1993	Allsop et al.	280/281.1
5,354,085	10/1994	Gally	280/284
5,356,165	10/1994	Kulhawik et al.	280/275
5,403,028	4/1995	Trimble	280/275
5,415,423	5/1995	Allsop et al.	280/281.1
5,452,910	9/1995	Harry	280/284
5,456,482	10/1995	Rau	280/284

OTHER PUBLICATIONS

Bicycling, Nov. 1994, pp. 30 & 112, the C4, Ganna, FX-6, Muddy Fox, Proflex and WCF Vertex bicycles.

Primary Examiner—Melody N. Brown

Attorney, Agent, or Firm—Evenson McKeown Edwards & Lenahan, PLLC

[57] CLAIM

The ornamental design for a bicycle frame, as shown and described.

DESCRIPTION

FIG. 1 is a right side view of a bicycle frame according to my novel design;

FIG. 2 is a left side view of a bicycle frame according to my novel design;

FIG. 3 is a front view of a bicycle frame according to my novel design;

FIG. 4 is a rear view of a bicycle frame according to my novel design;

FIG. 5 is a perspective view from above and the right side of the bicycle frame according to my novel design;

FIG. 6 is a perspective view from above and the front of the bicycle frame according to my novel design; and,

FIG. 7 is a top view of the bicycle frame according to my novel design.

The dash line showings are for purposes of depicting the environment and are not part of the claimed design.

1 Claim, 5 Drawing Sheets

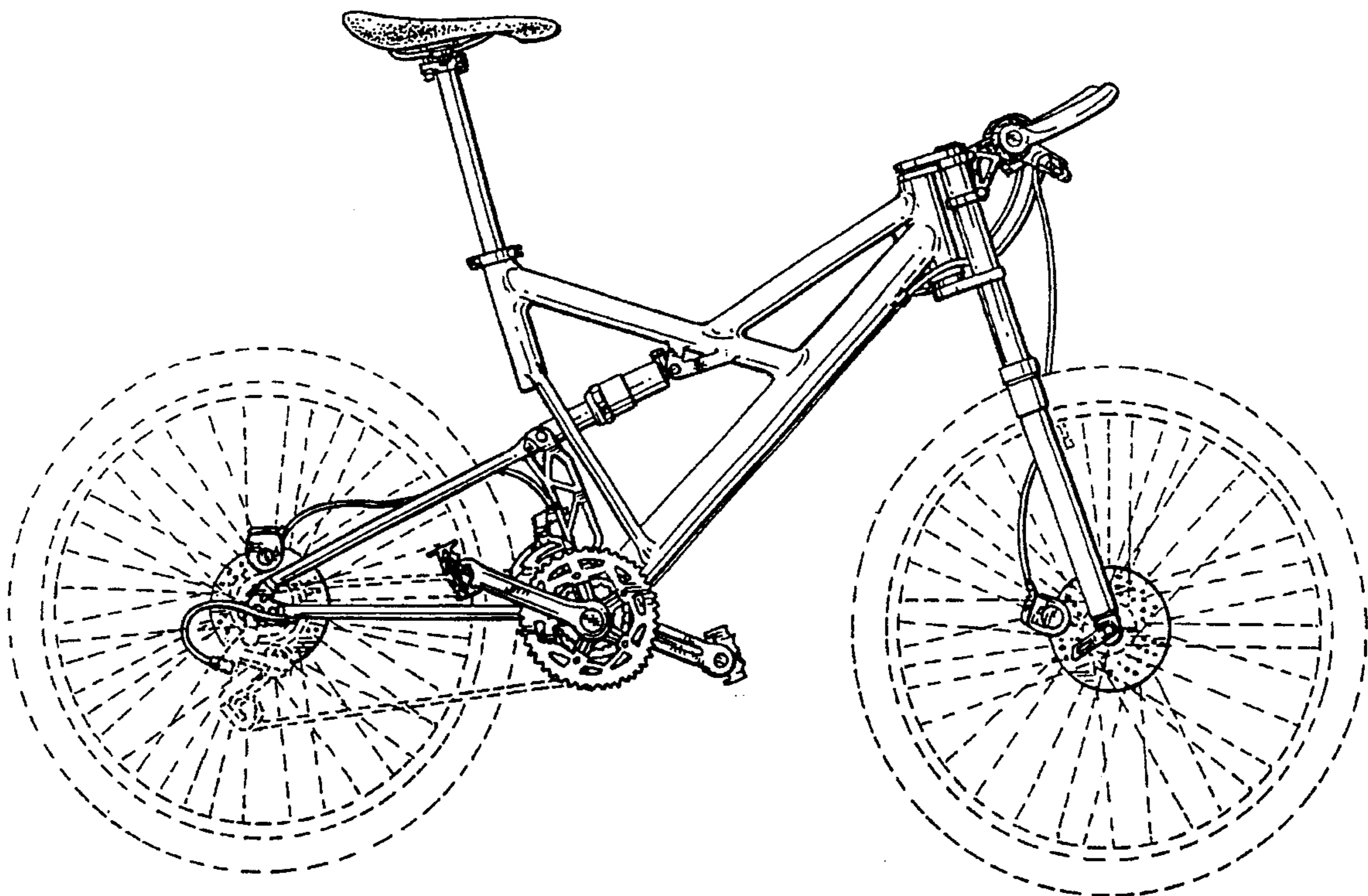

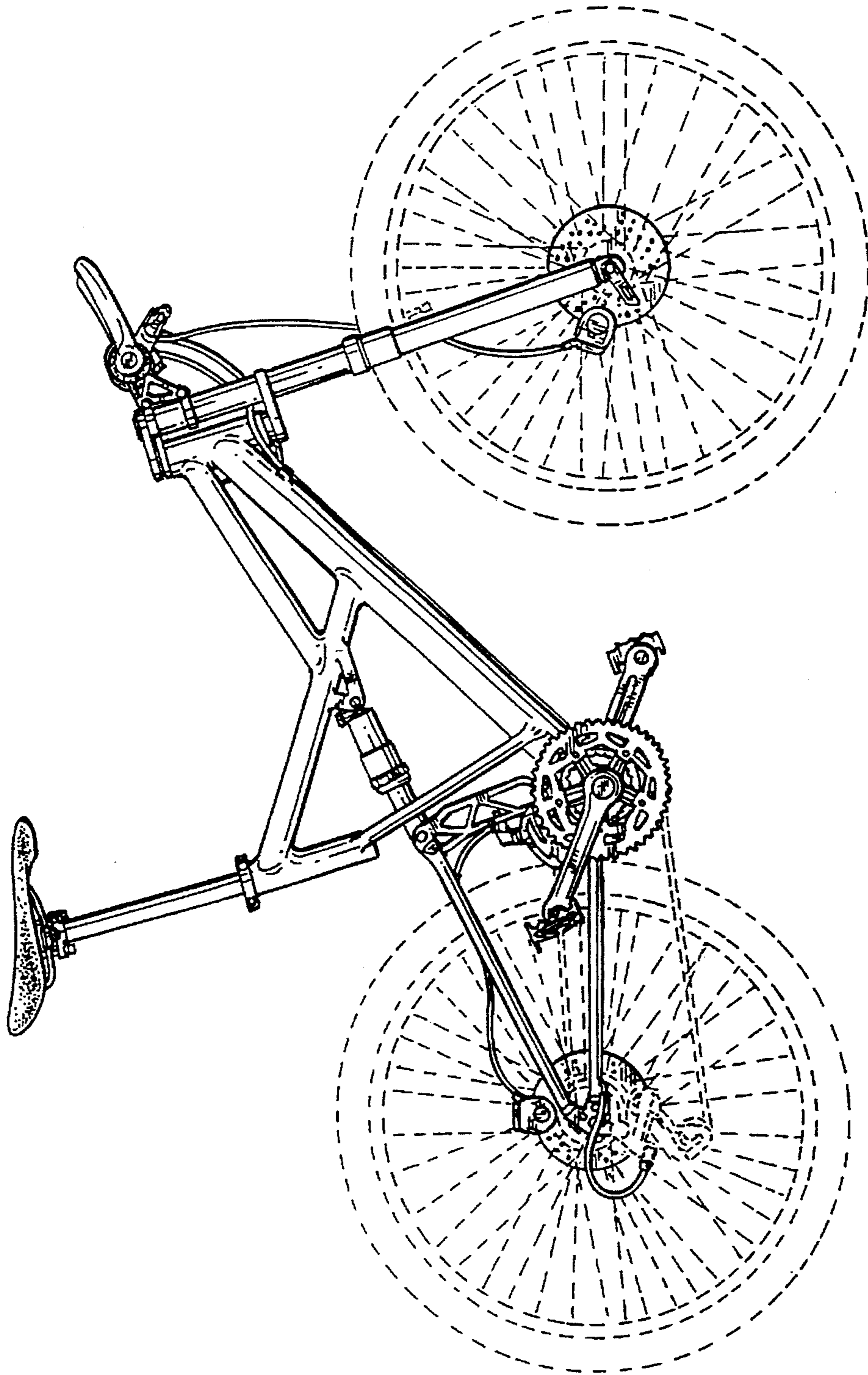

FIG. 1

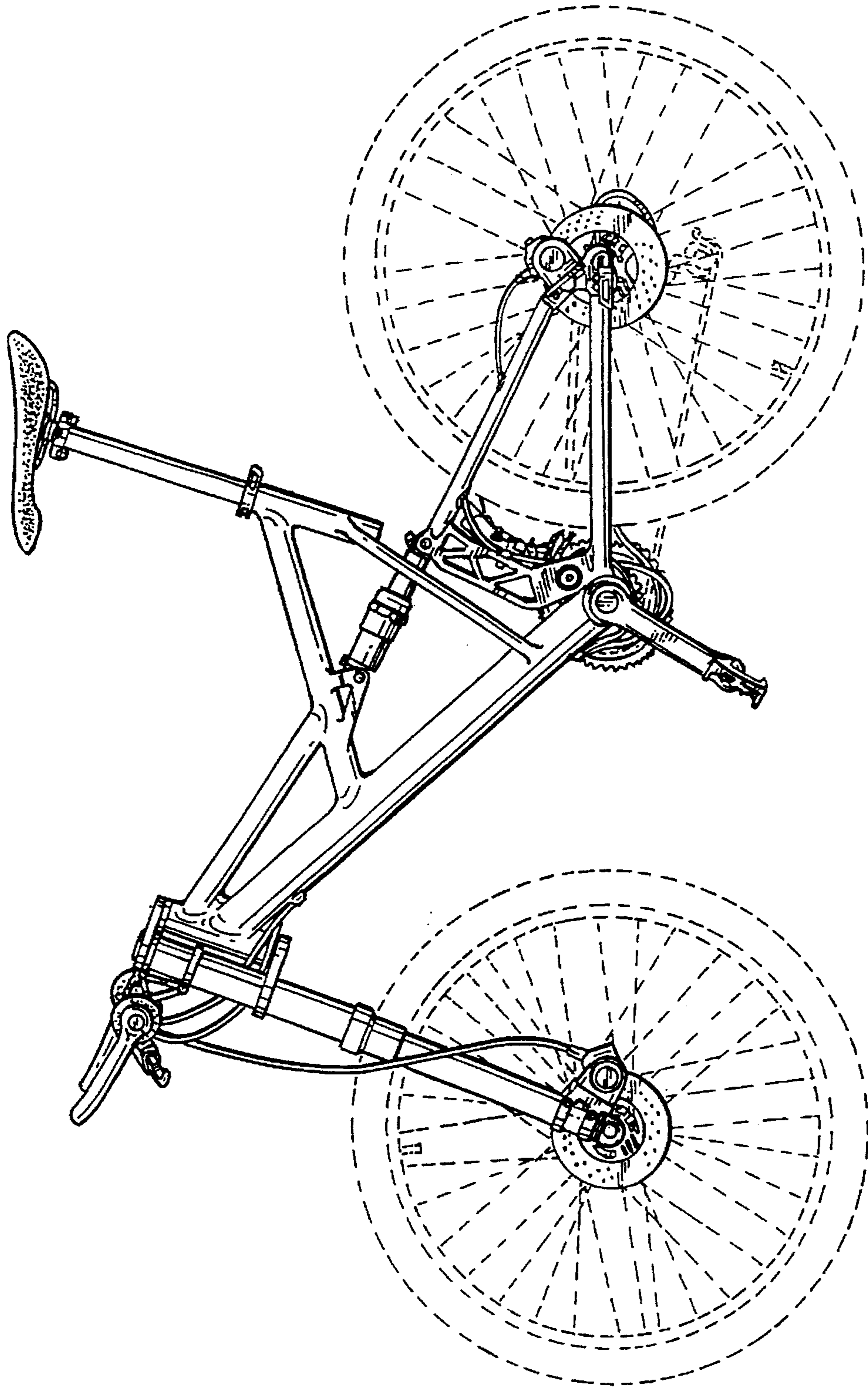

FIG. 2

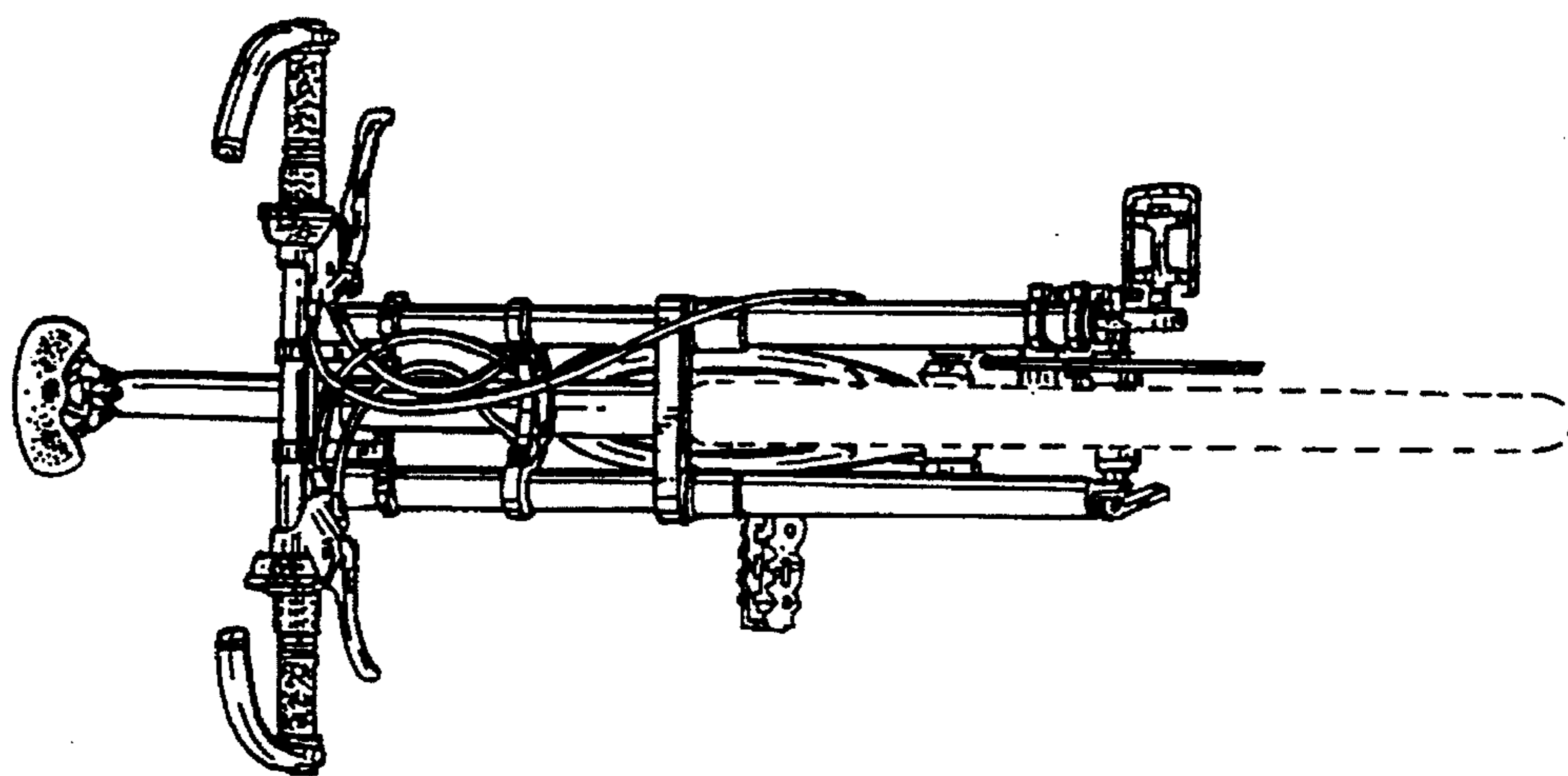

FIG. 3

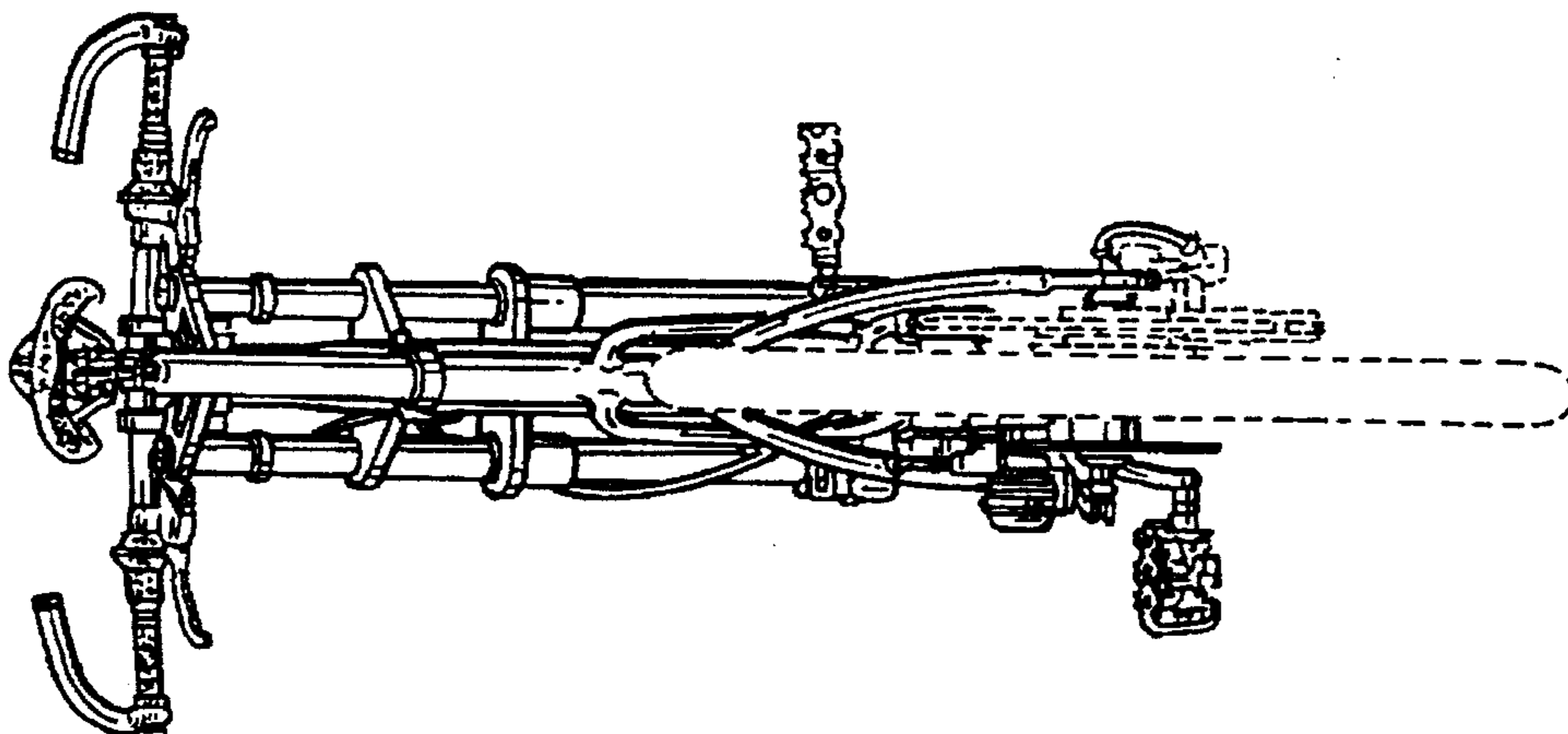

FIG. 4

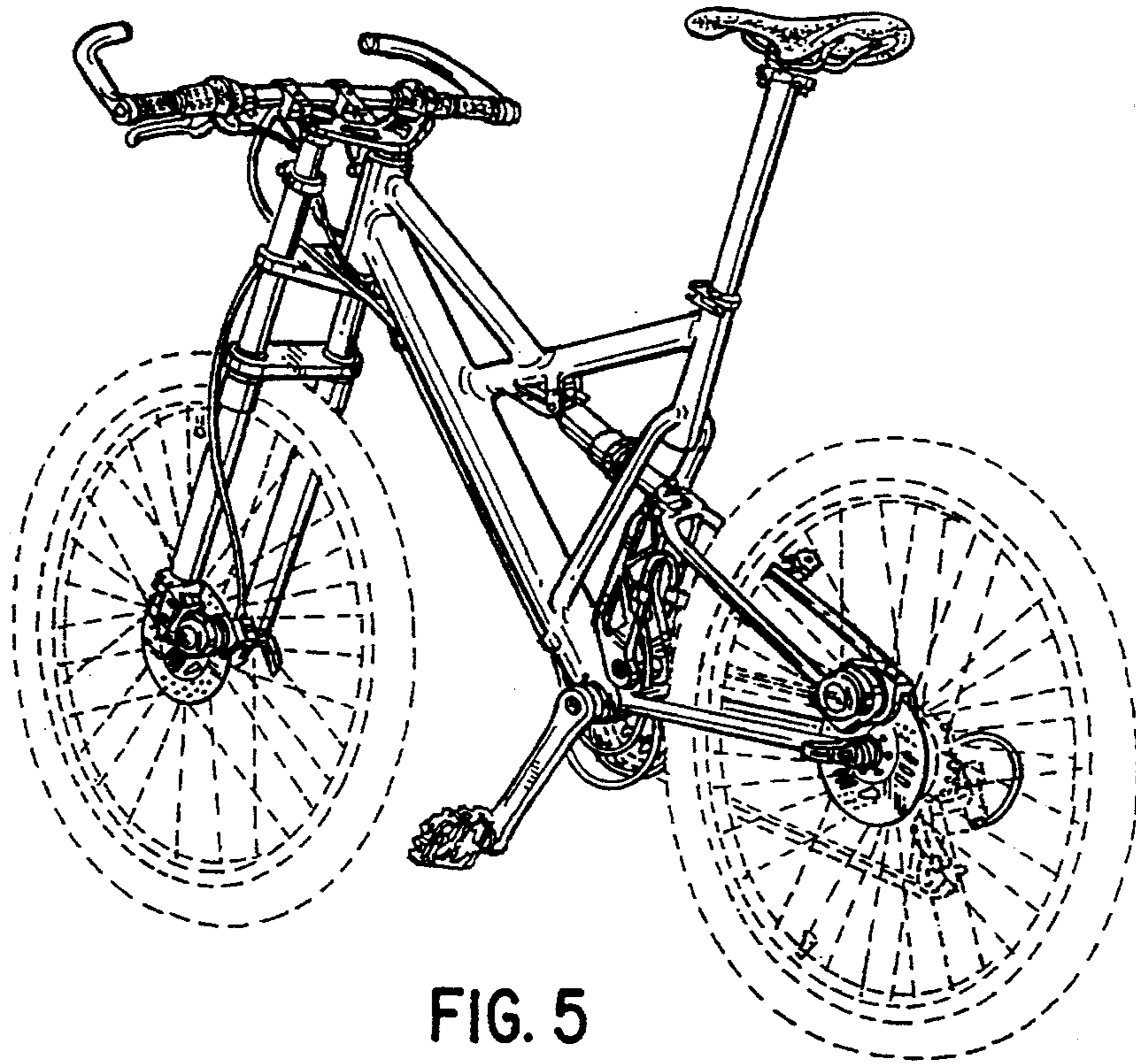

FIG. 5

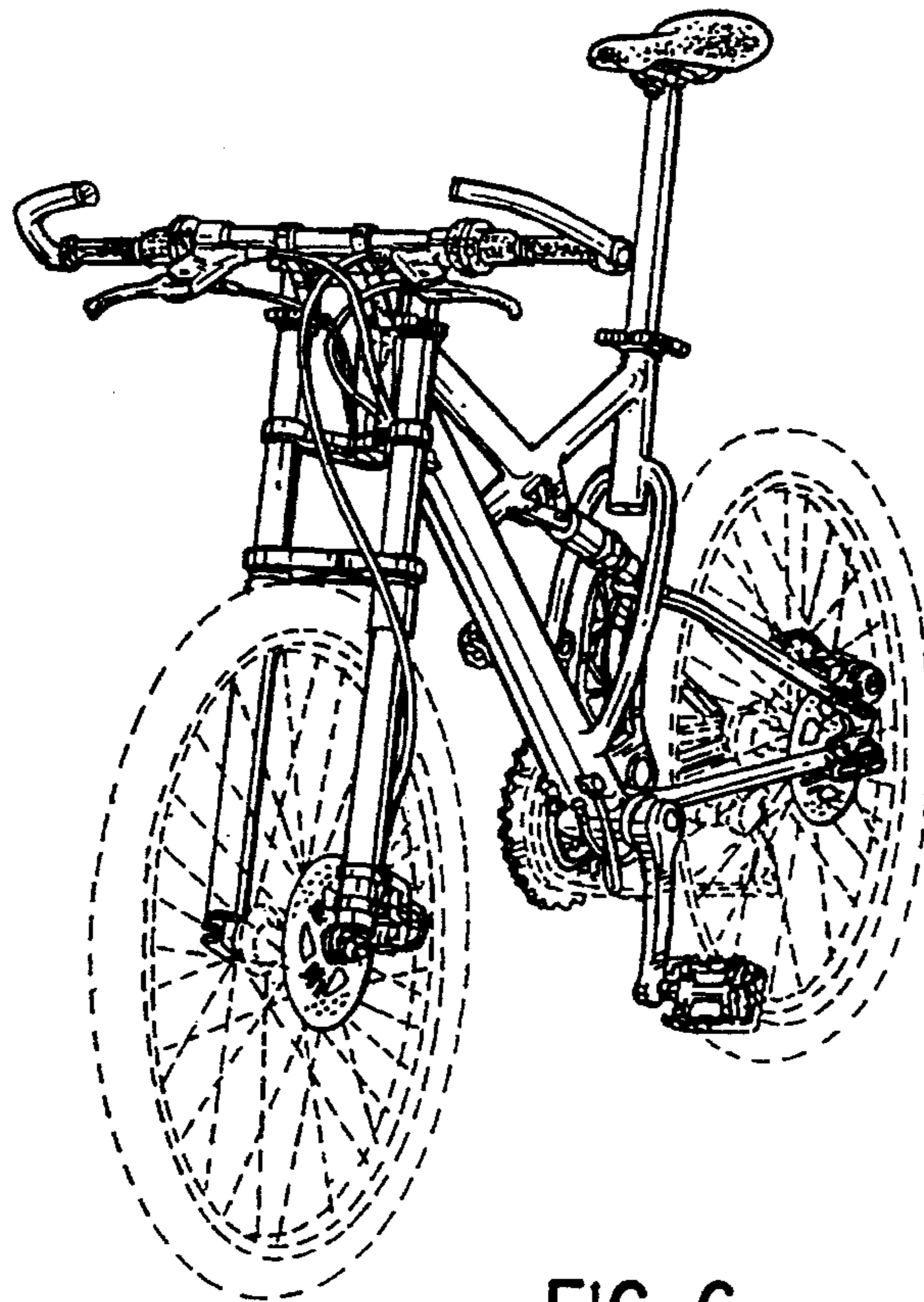

FIG. 6

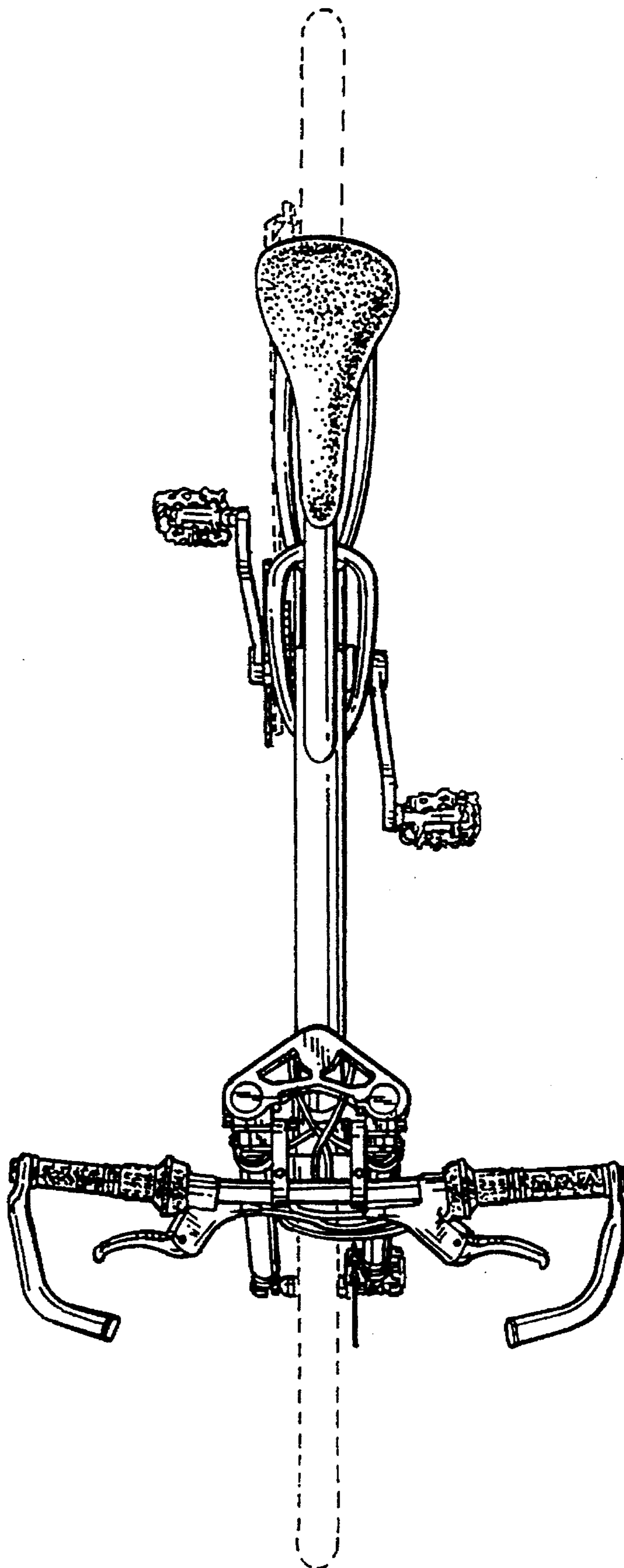

FIG. 7