



US00D377160S

United States Patent [19]
Murkett

[11] **Patent Number:** **Des. 377,160**
[45] **Date of Patent:** ****Jan. 7, 1997**

[54] **SPOILER FOR A MOTOR VEHICLE**

[75] Inventor: **Stephen Murkett**, Gerlingen, Germany

[73] Assignee: **Dr. Ing. h.c.F. Porsche AG**, Weissach, Germany

[**] Term: **14 Years**

[21] Appl. No.: **38,766**

[22] Filed: **May 11, 1995**

[30] **Foreign Application Priority Data**

Nov. 11, 1994 [DE] Germany 94 08 797.0

[52] **U.S. Cl.** **D12/181**

[58] **Field of Search** D12/181, 196;
296/180.1

[56] **References Cited**

U.S. PATENT DOCUMENTS

D. 360,609 7/1995 Ramaciotti D12/196

OTHER PUBLICATIONS

Road & Track, Feb. 1994, pp 102 & 104, Rear Spoiler on Porsche 911 Automobile, bottom of page.

Electrodyne Spring 1980 Catalog, p. 36, Whaletail Spoilers for Porsche 911, right side of page.

Primary Examiner—Freda Nunn

Attorney, Agent, or Firm—Evenson, McKeown, Edwards & Lenahan, P.L.L.C.

[57] **CLAIM**

The ornamental design for a spoiler for a motor vehicle, as shown and described.

DESCRIPTION

FIG. 1 is a right side view of a spoiler for a motor vehicle according to my novel design;

FIG. 2 is a right front perspective view of a spoiler for a motor vehicle according to my novel design;

FIG. 3 is a right rear perspective view of a spoiler for a motor vehicle according to my novel design;

FIG. 4 is a rear view of a spoiler for a motor vehicle according to my novel design;

FIG. 5 is a top view of a spoiler for a motor vehicle according to my novel design;

FIG. 6 is a rear view of a spoiler for a motor vehicle according to my novel design;

FIG. 7 is a front view of a spoiler for a motor vehicle according to my novel design;

FIG. 8 is a slightly enlarged side view of a spoiler for a motor vehicle according to my novel design, it being understood that the opposite side is a mirror image thereof; and,

FIG. 9 is an enlarged fragmentary front perspective view of one end of a spoiler for a motor vehicle according to my novel design.

The broken line showing of a portion of a motor vehicle in FIGS. 1-4 and the elements shown on the bottom of the spoiler in FIG. 7-9 of the drawings is for illustrative purposes only and forms no part of the claimed design.

1 Claim, 5 Drawing Sheets

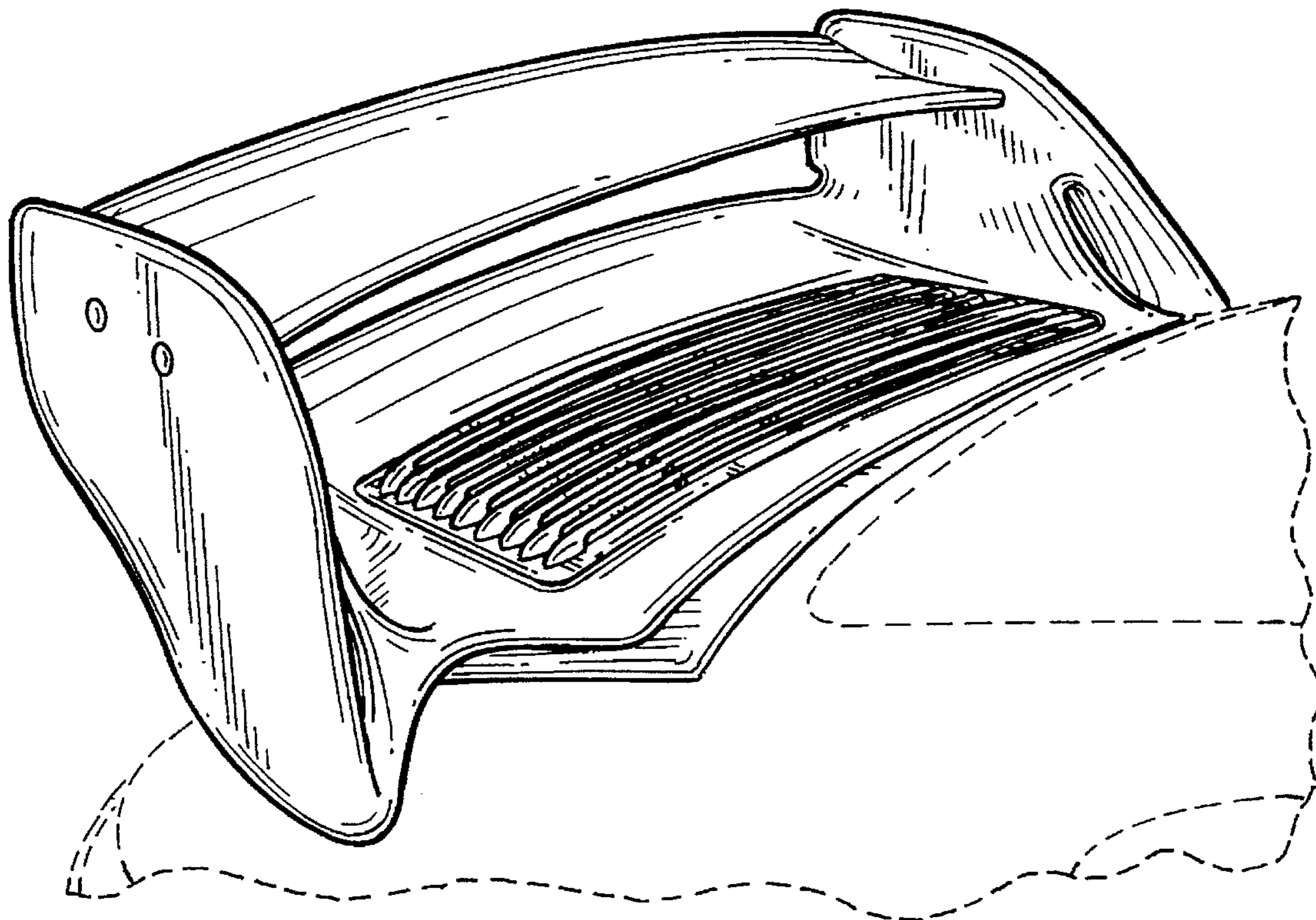

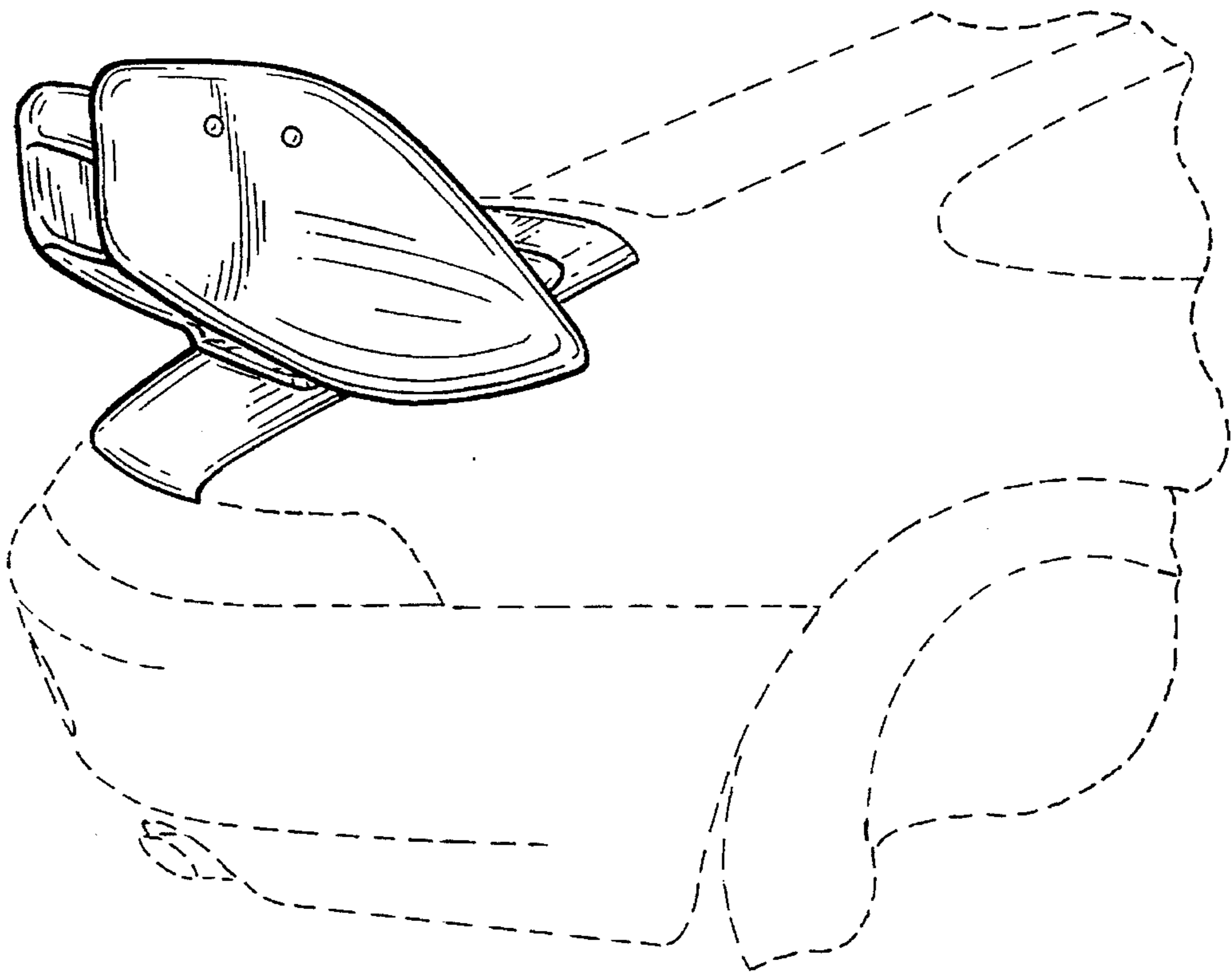

FIG. 1

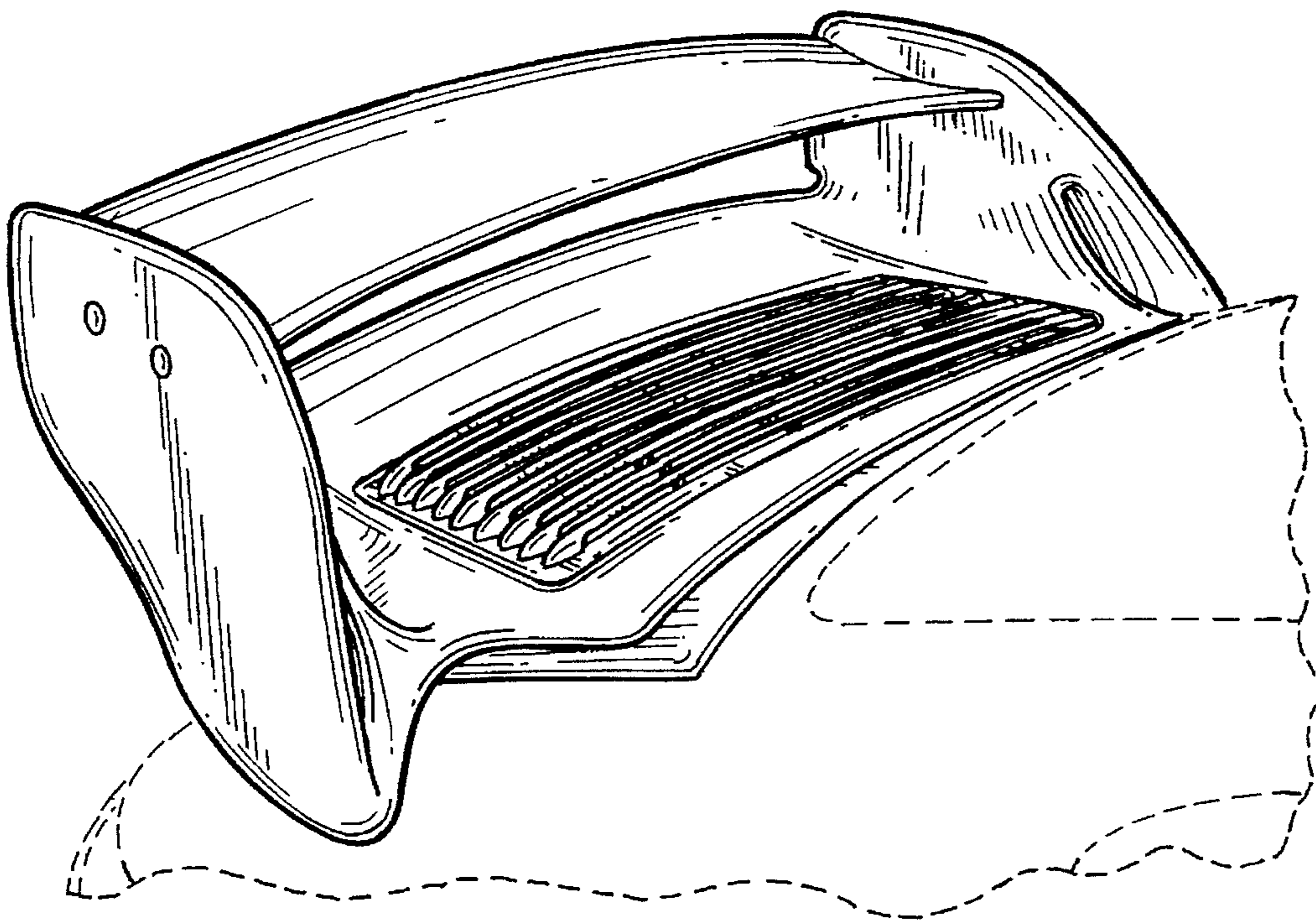

FIG. 2

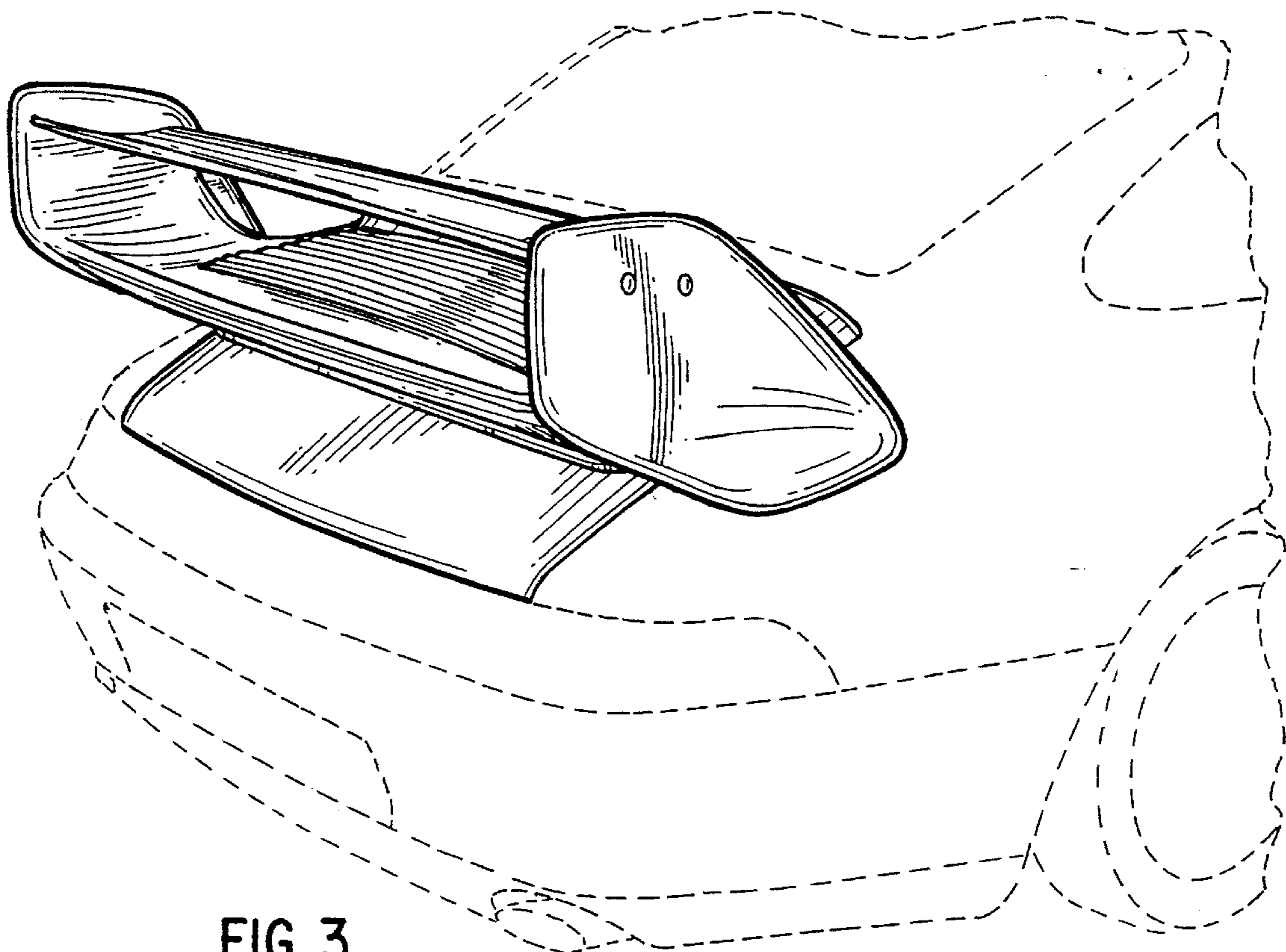

FIG. 3

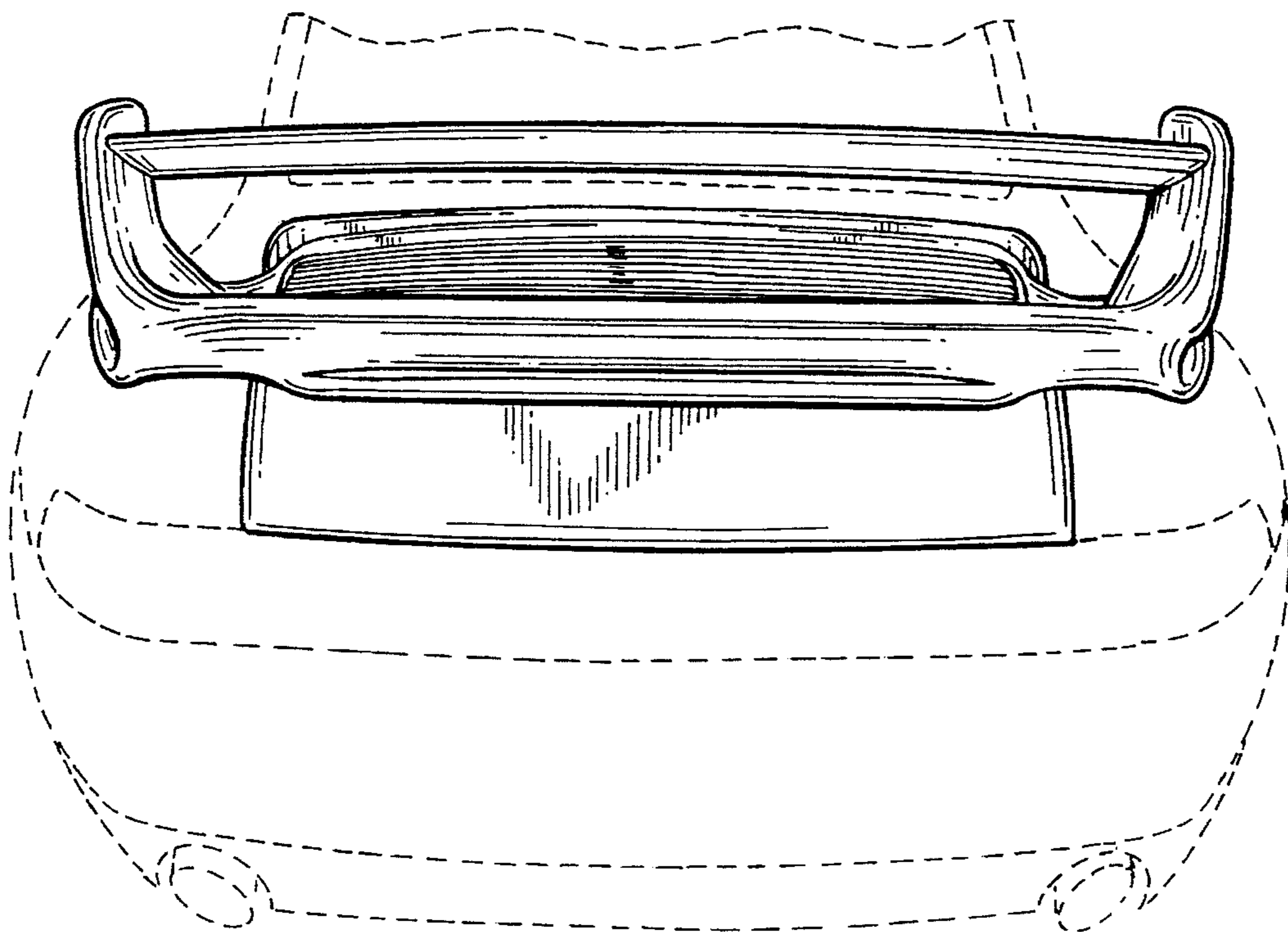

FIG. 4

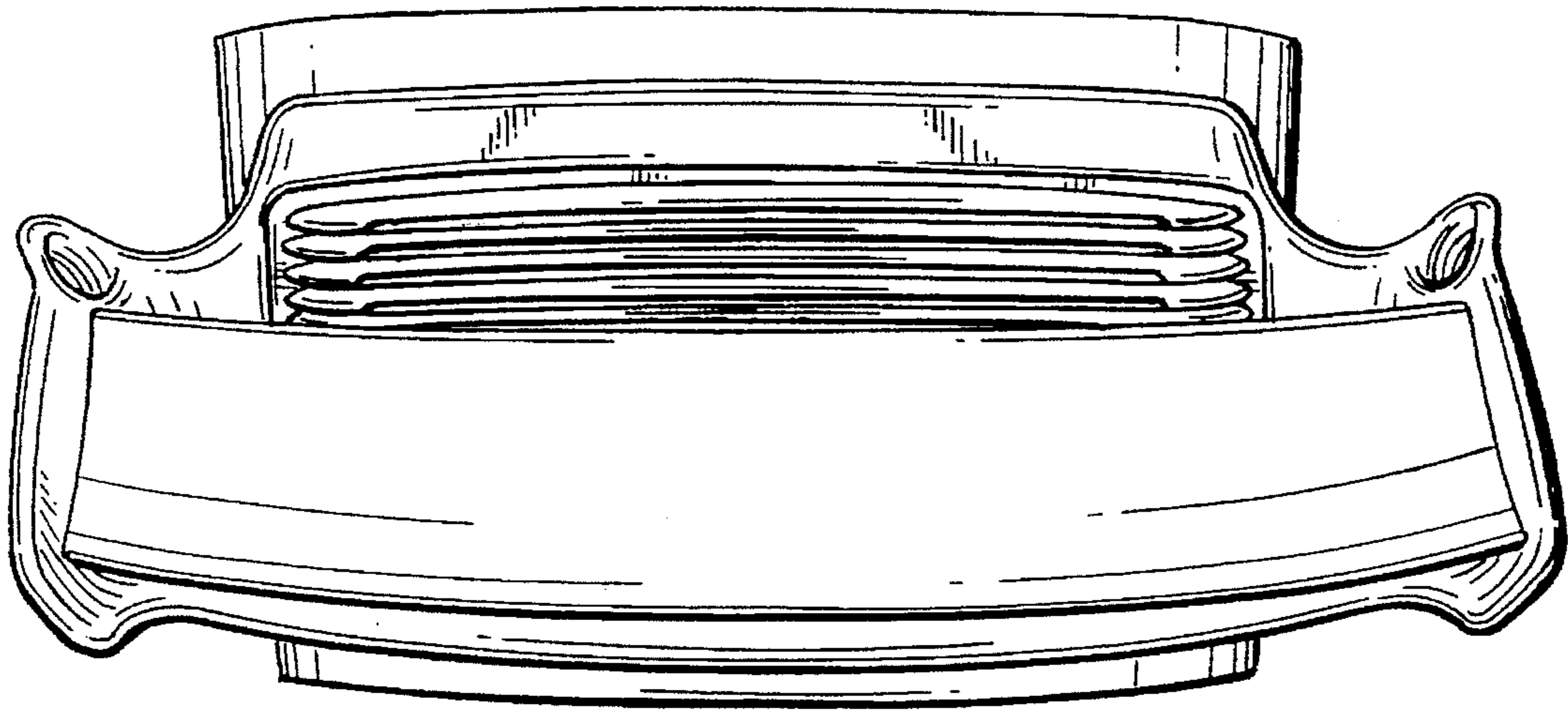

FIG. 5

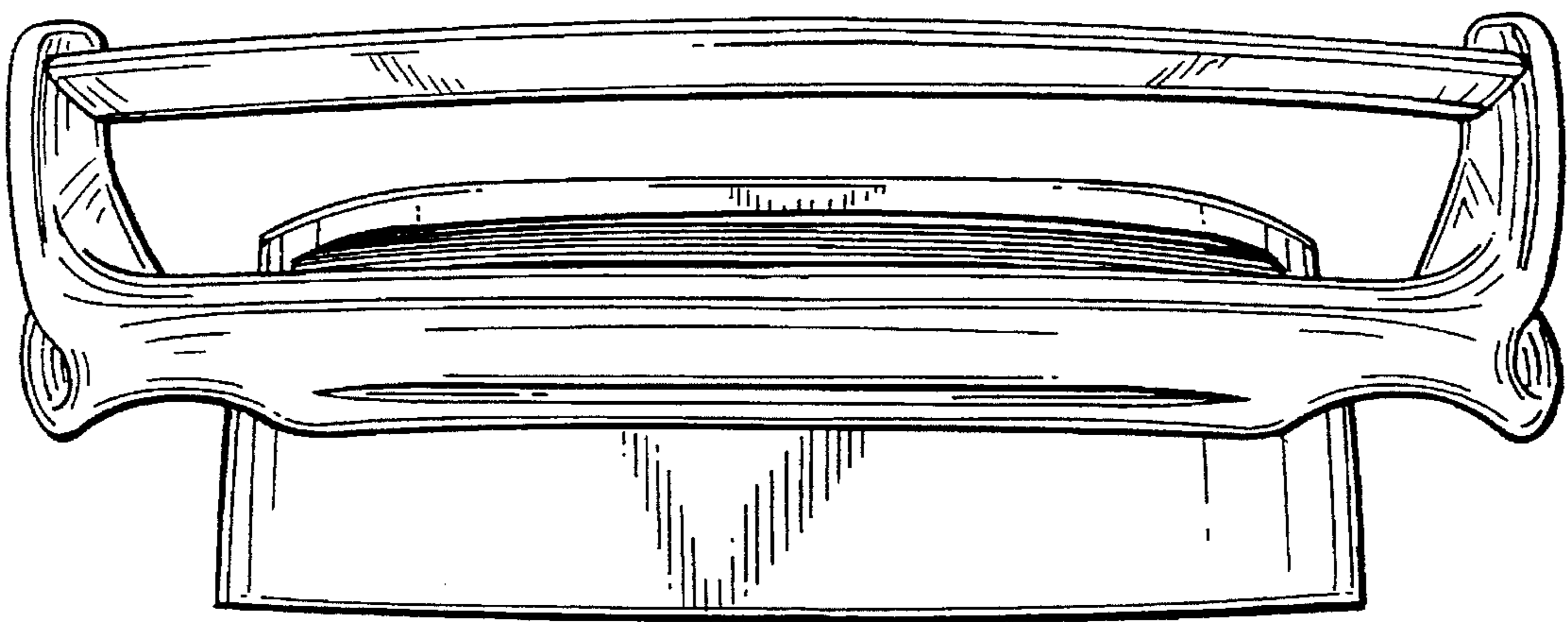

FIG. 6

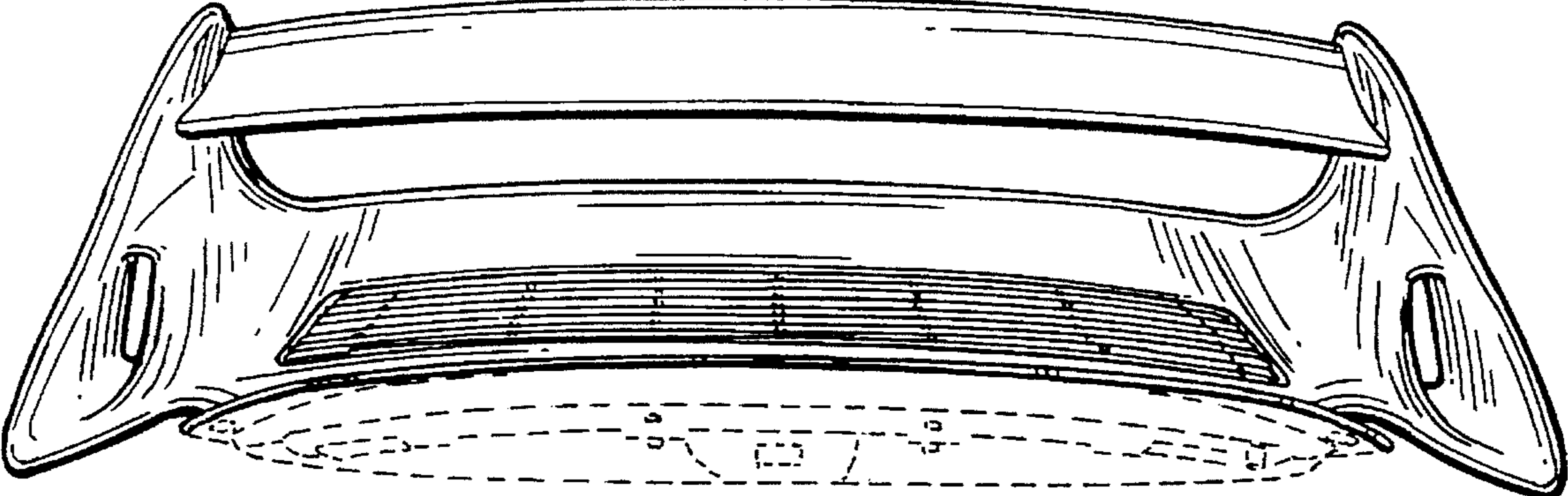

FIG. 7

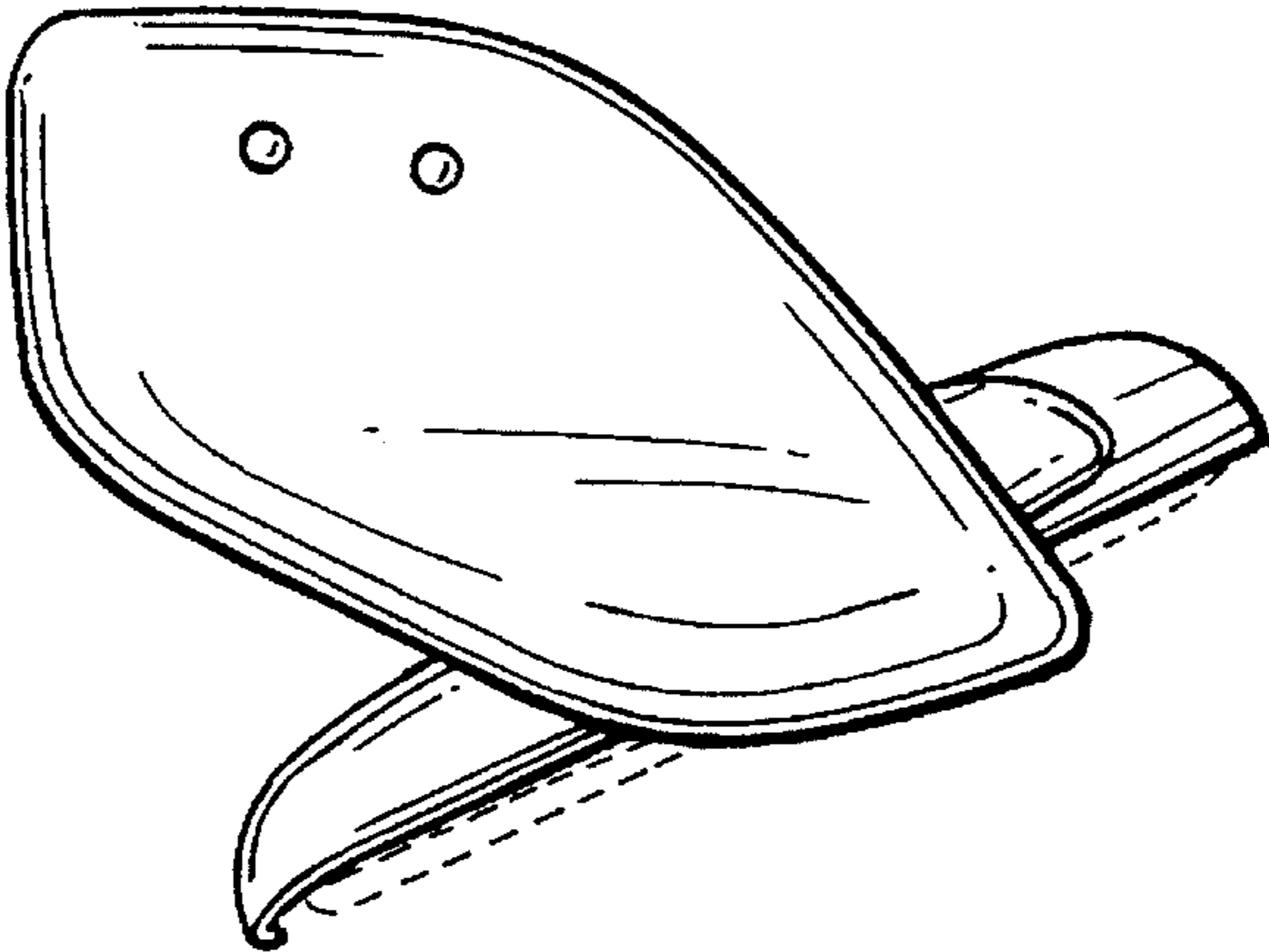

FIG. 8

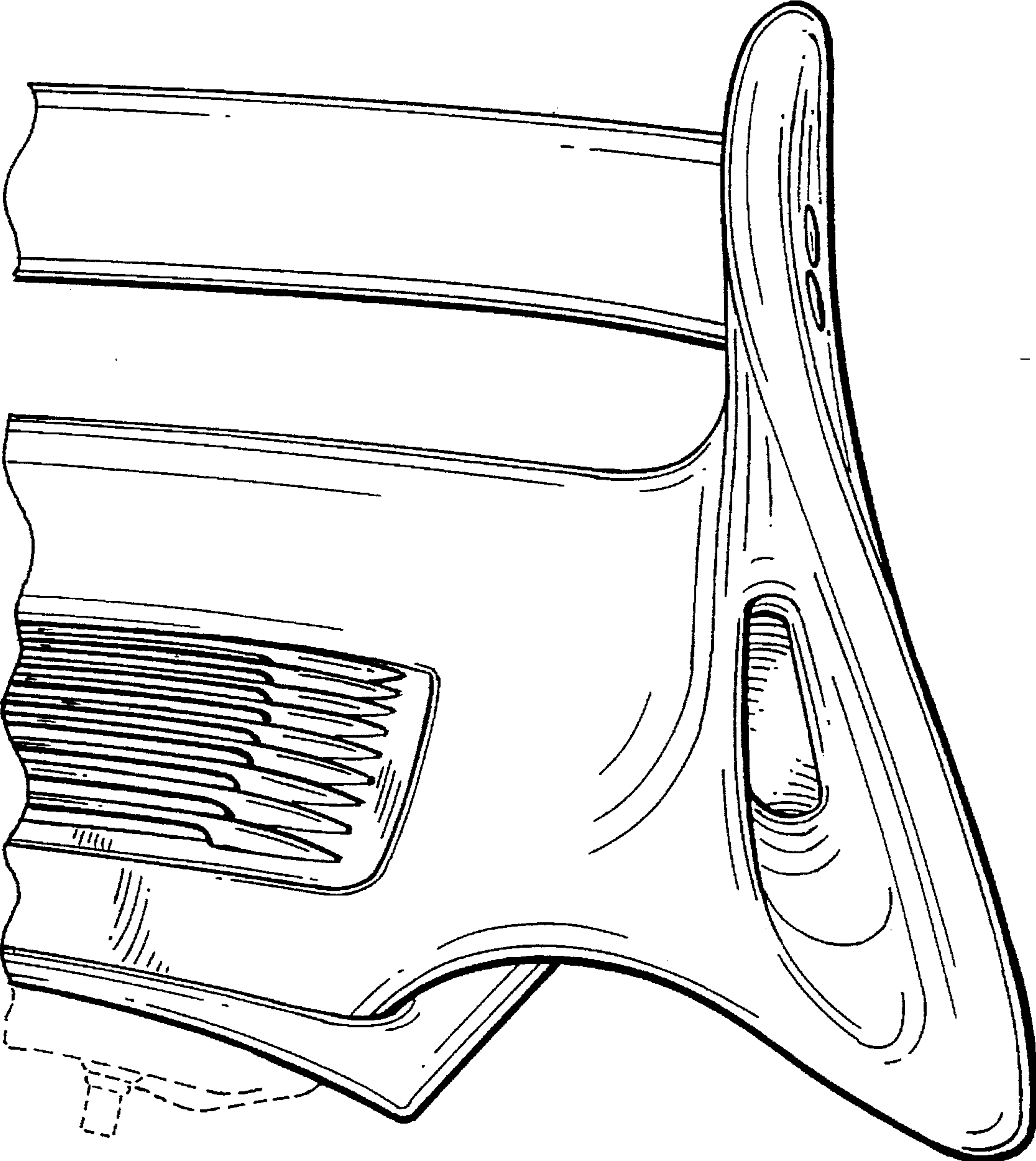

FIG. 9