



US00D377001S

United States Patent [19]

Martin et al.

[11] Patent Number: **Des. 377,001**

[45] Date of Patent: ****Dec. 31, 1996**

[54] **SLIDING FIFTH WHEEL UNIT**

5,016,898 5/1991 Works et al. 280/433
5,344,172 9/1994 Jaun 280/415.1

[76] Inventors: **Ronald G. Martin; Patricia A. Martin**, both of 2272 Bolyston Rd., Ellensburg, Wash. 98926

Primary Examiner—Melody N. Brown
Attorney, Agent, or Firm—Dennis H. Lambert

[**] Term: **14 Years**

[57] **CLAIM**

[21] Appl. No.: **48,042**

The ornamental design for a sliding fifth wheel unit, as shown and described.

[22] Filed: **Dec. 18, 1995**

DESCRIPTION

[52] U.S. Cl. **D12/161**

[58] Field of Search D12/161; 280/415.1, 280/416.1, 418.1, 420, 425.1, 433, 434

FIG. 1 is a front, top and side perspective view of the sliding fifth wheel unit embodying the design of the present invention, showing a truck cab and portion of the truck frame in broken lines for illustrative purposes only and forming no part of the claimed design dashed lines;

FIG. 2 is a rear elevational view thereof;

FIG. 3 is a front elevational view thereof;

FIG. 4 is a side elevational view thereof, the side opposite being a mirror image of the side shown in FIG. 4;

FIG. 5 is a top plan view thereof; and,

FIG. 6 is bottom plan view thereof.

[56] **References Cited**

U.S. PATENT DOCUMENTS

D. 196,572	10/1963	Harbers	D12/161
D. 317,743	6/1991	Chambers	D12/161
3,360,280	12/1967	Betchart	280/407
3,604,721	9/1971	Hulverson	280/418.1 X
3,820,821	6/1974	Leland	280/433 X
4,824,134	4/1989	Harris	280/423.1 X
4,826,199	5/1989	Chambers	280/434

1 Claim, 3 Drawing Sheets

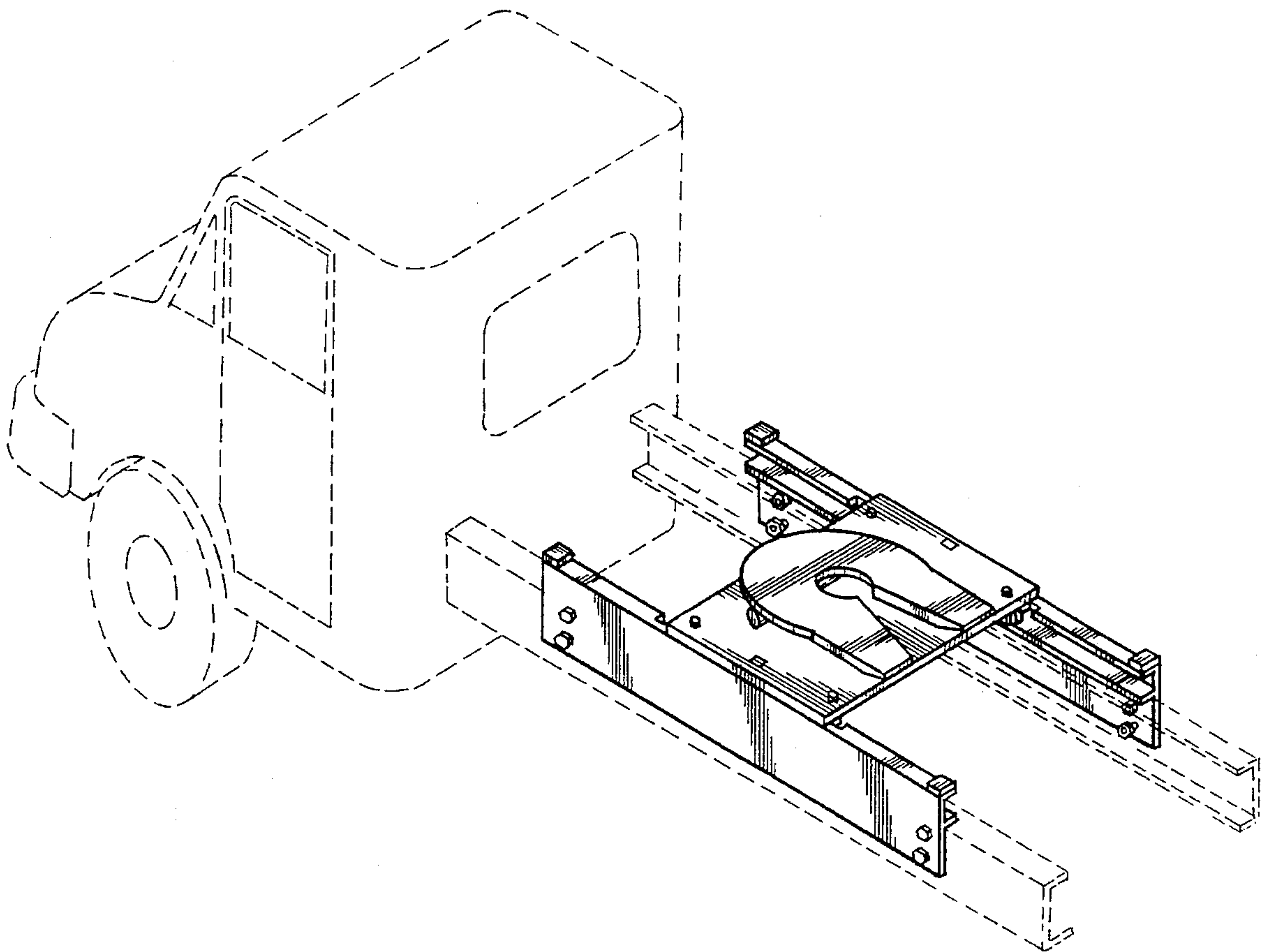

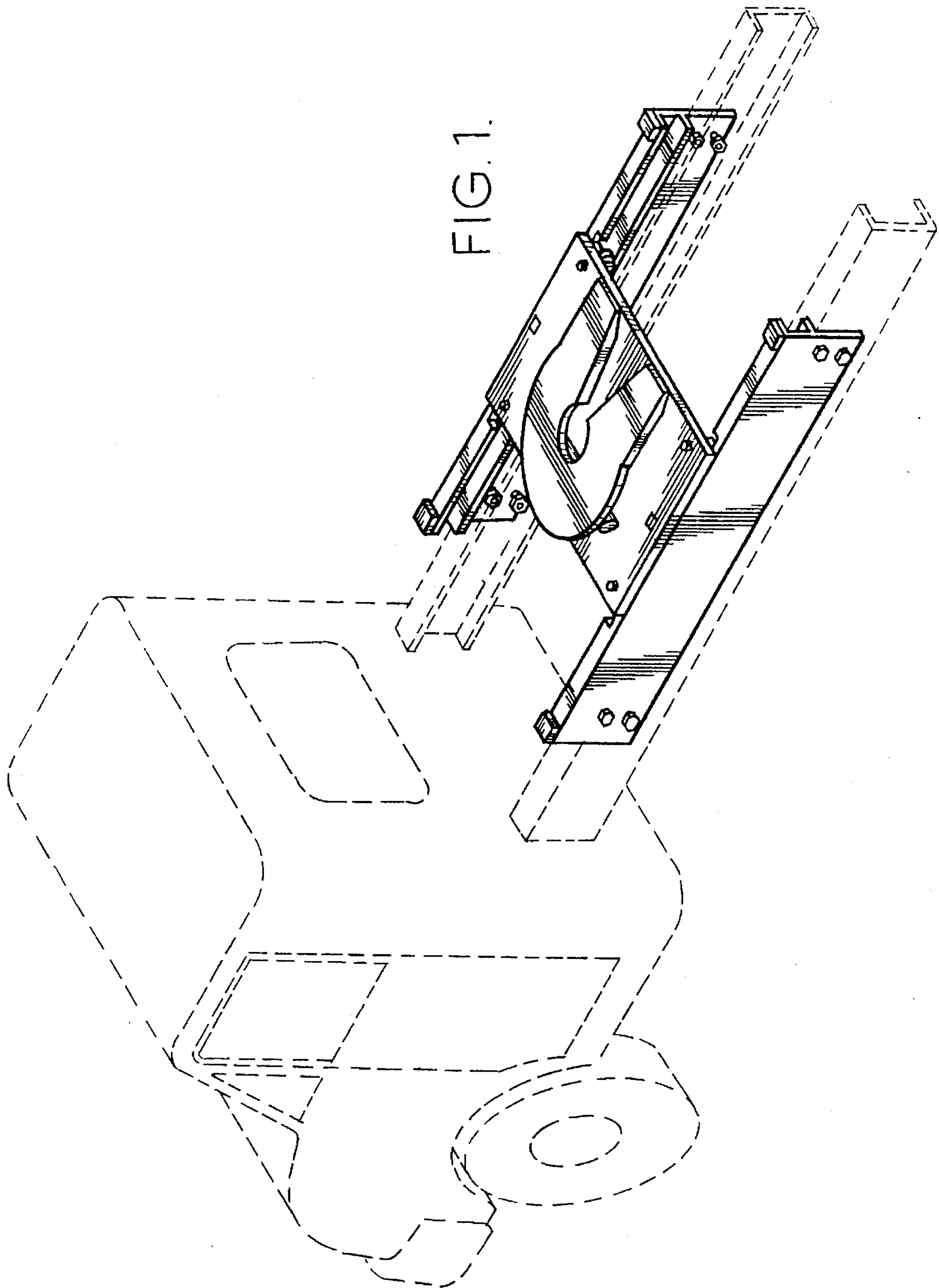

FIG. 6.

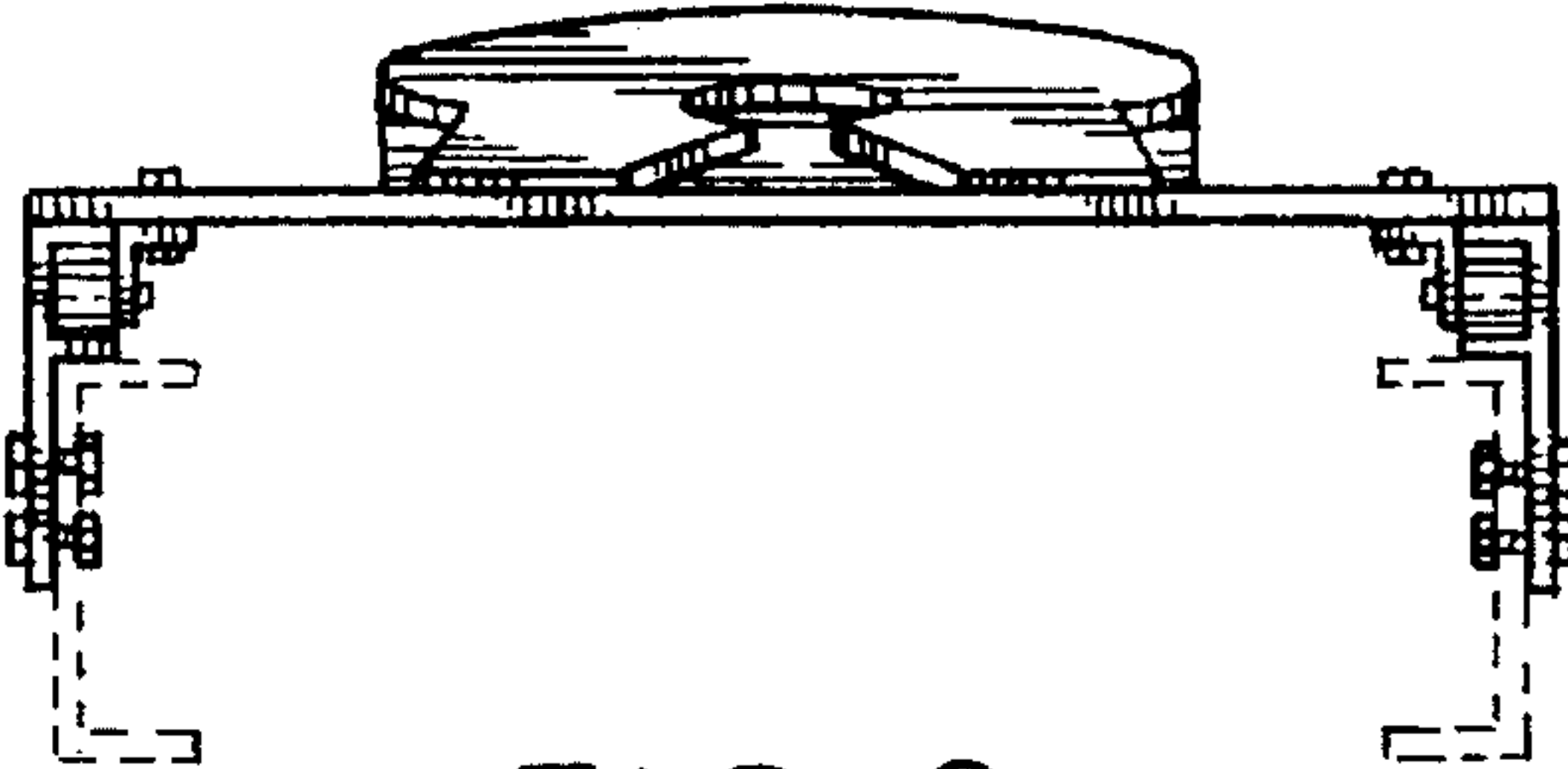
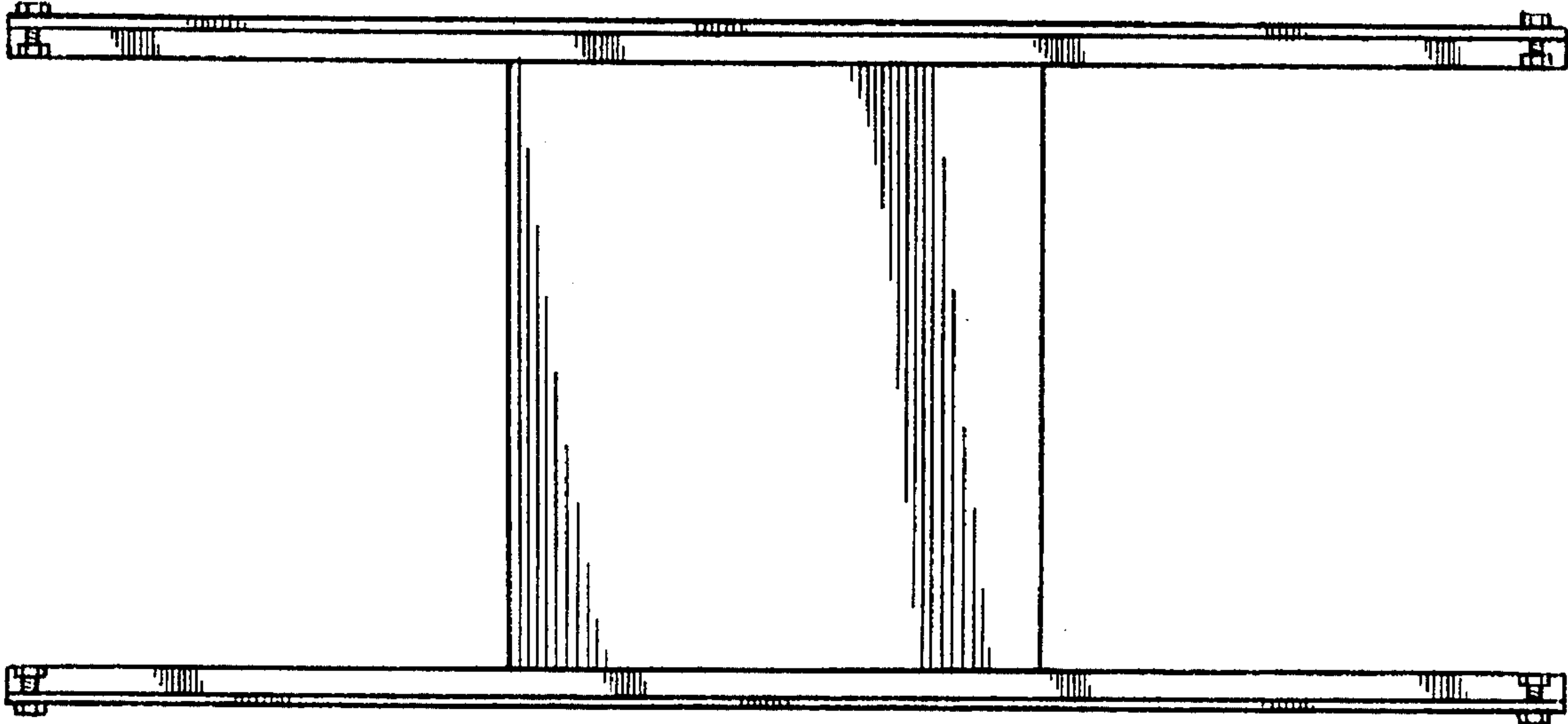

FIG. 2.

FIG. 5.

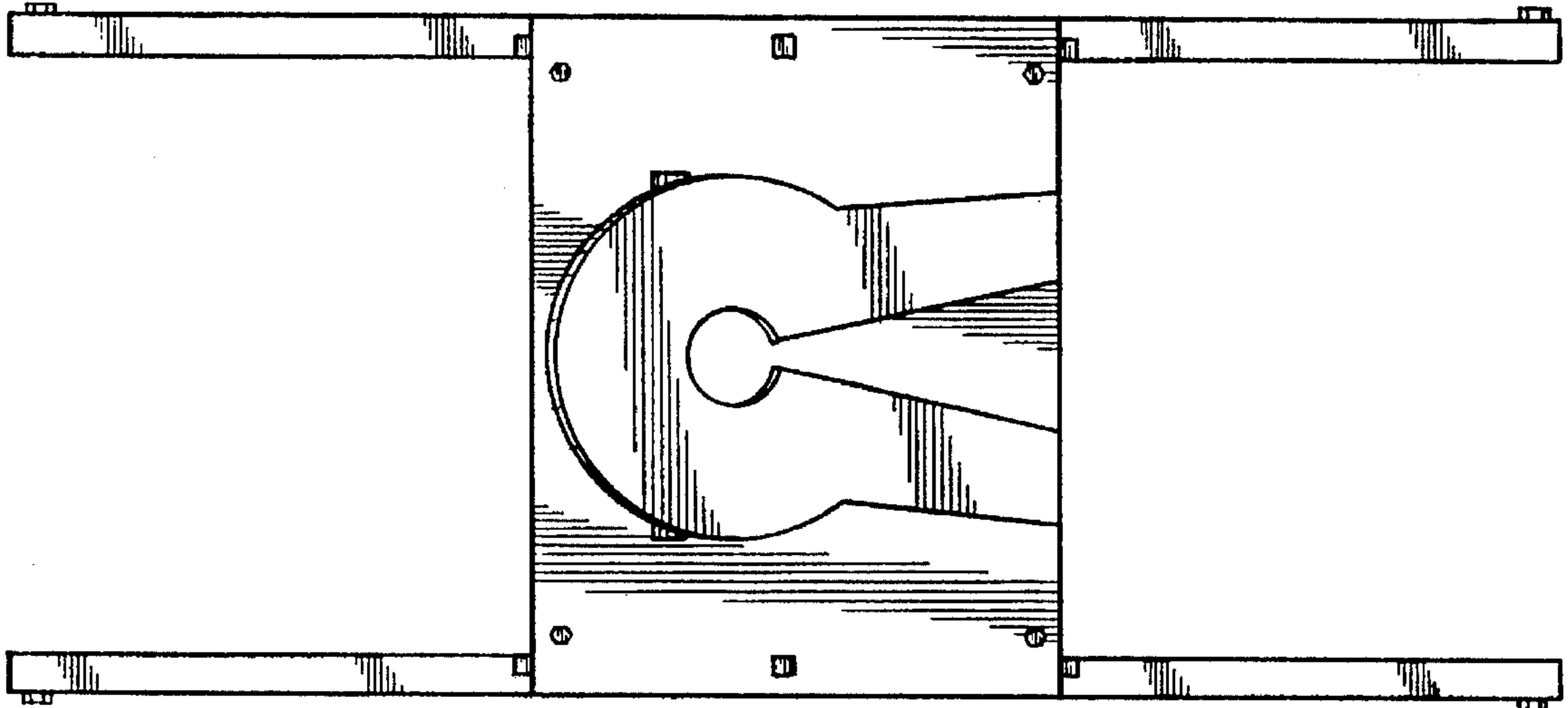

FIG. 4.

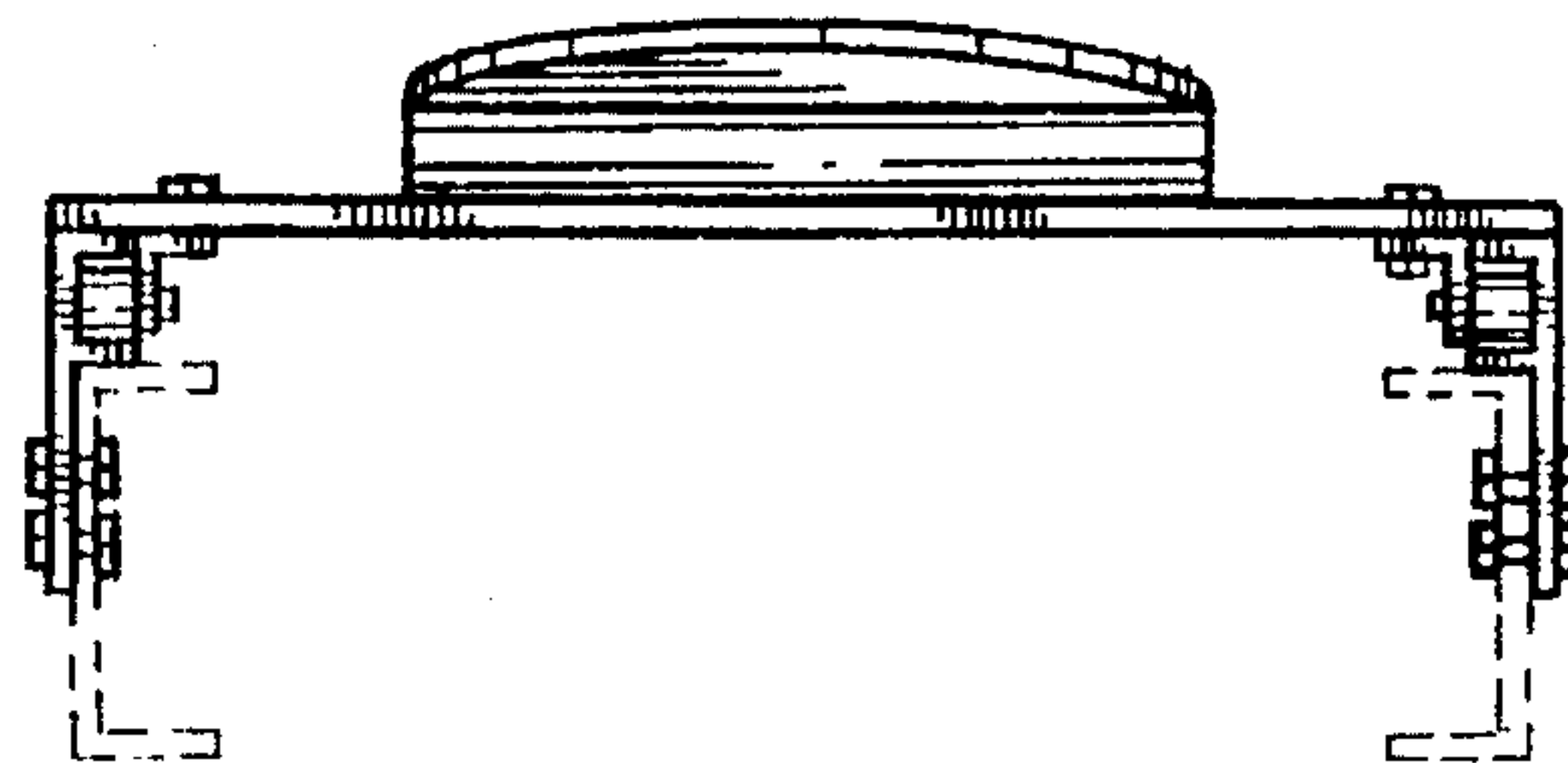
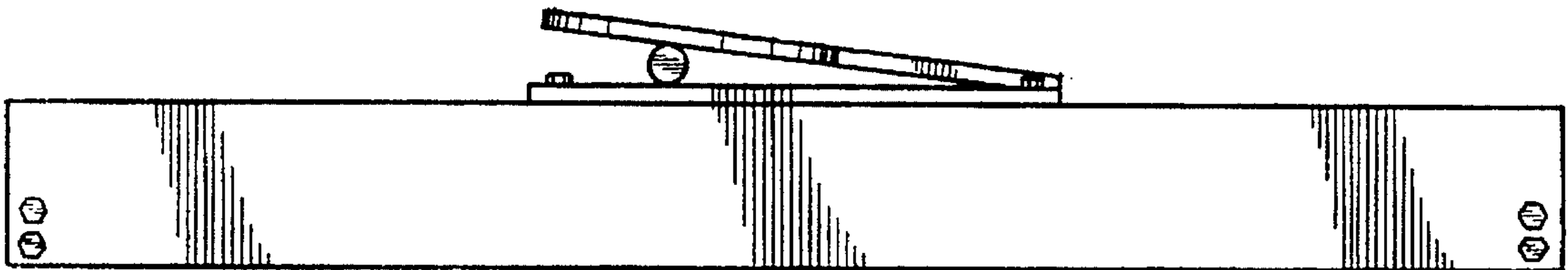

FIG. 3.