



US00D376996S

# United States Patent [19]

Soucy et al.

[11] Patent Number: **Des. 376,996**

[45] Date of Patent: **\*\*Dec. 31, 1996**

## [54] TRACK FOR A VEHICLE

[75] Inventors: **Gilles Soucy; Jean Watelle; Claude Faucher**, all of Drummondville, Canada

[73] Assignees: **Kimpex, Inc.; Quimpex Limitee**, both of Drummondville, Canada

[\*\*] Term: **14 Years**

[21] Appl. No.: **31,979**

[22] Filed: **Dec. 12, 1994**

### [30] Foreign Application Priority Data

Jun. 22, 1994 [CA] Canada ..... 1994-1209

[52] U.S. Cl. .... **D12/7**

[58] Field of Search ..... D12/7, 3, 1, 154; 305/35 EB, 39, 54; 180/190, 9.1; D15/28

### [56] References Cited

#### U.S. PATENT DOCUMENTS

D. 260,899	9/1981	Joseph et al. ....	D12/7
D. 283,206	4/1986	Talbot .....	D12/7
D. 298,018	10/1988	Cartwright .....	D12/3
D. 342,044	12/1993	Hornai .....	D12/7
3,236,568	2/1966	Bombardier .....	305/12
3,533,663	10/1970	Pianalto .....	305/35
4,043,610	8/1977	Halmosi .....	305/19
4,573,746	3/1986	Prinoth .....	305/35
4,795,221	1/1989	Simmons .....	305/35 EB
4,957,472	9/1990	Nakano .....	474/203

## FOREIGN PATENT DOCUMENTS

52-2924 11/1977 Japan .  
1-229782 9/1989 Japan .

*Primary Examiner*—Melody N. Brown  
*Attorney, Agent, or Firm*—Baker & Daniels

### [57] CLAIM

The ornamental design for a track for a vehicle, as shown and described.

### DESCRIPTION

FIG. 1 is a perspective view taken from above and from the rear of a portion of a track for a vehicle showing our new design, it being understood that the tread design continues uniformly through the belt indicated in light full lines;

FIG. 2 is an enlarged perspective view taken from above and from the rear of a portion of a track for a vehicle showing our new design, shown broken away for convenience of illustration;

FIG. 3 is an enlarged perspective view taken from below and from the rear of a portion of a track for a vehicle showing our new design, shown broken away for convenience of illustration;

FIG. 4 is top plan view thereof;

FIG. 5 is a bottom plan view thereof;

FIG. 6 is a side elevation thereof; and,

FIG. 7 is a front elevation thereof.

**1 Claim, 5 Drawing Sheets**

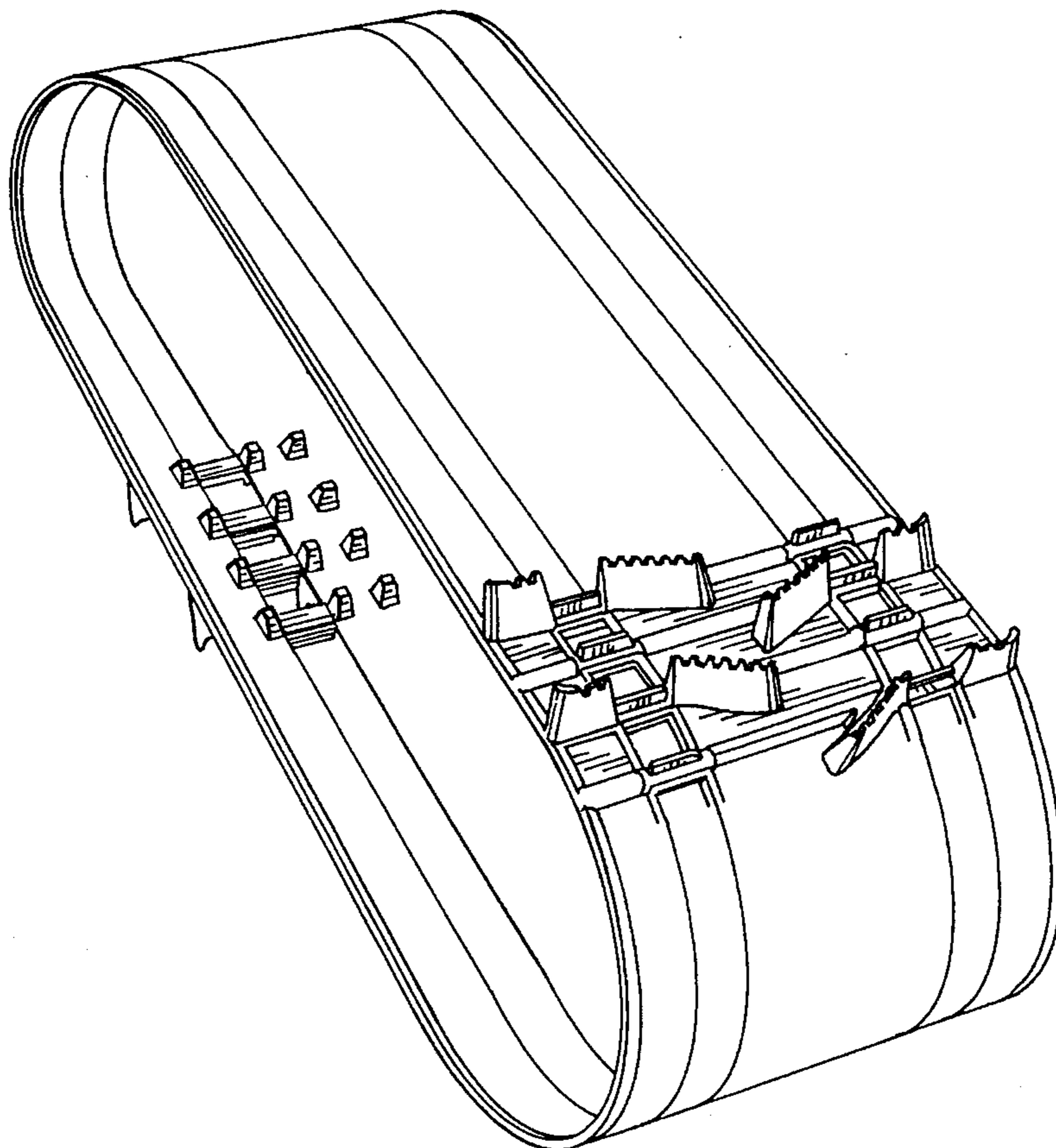

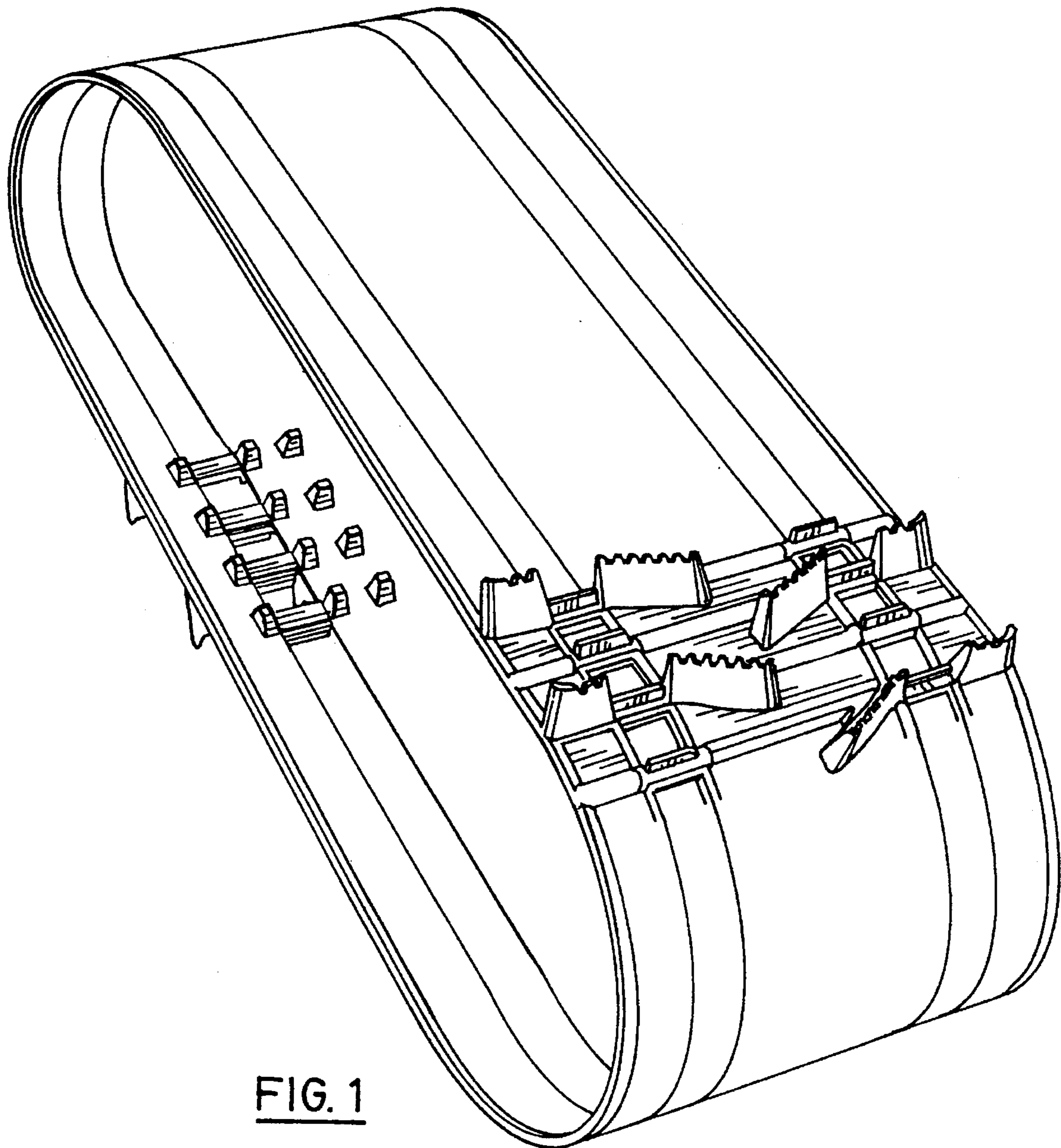

FIG. 1

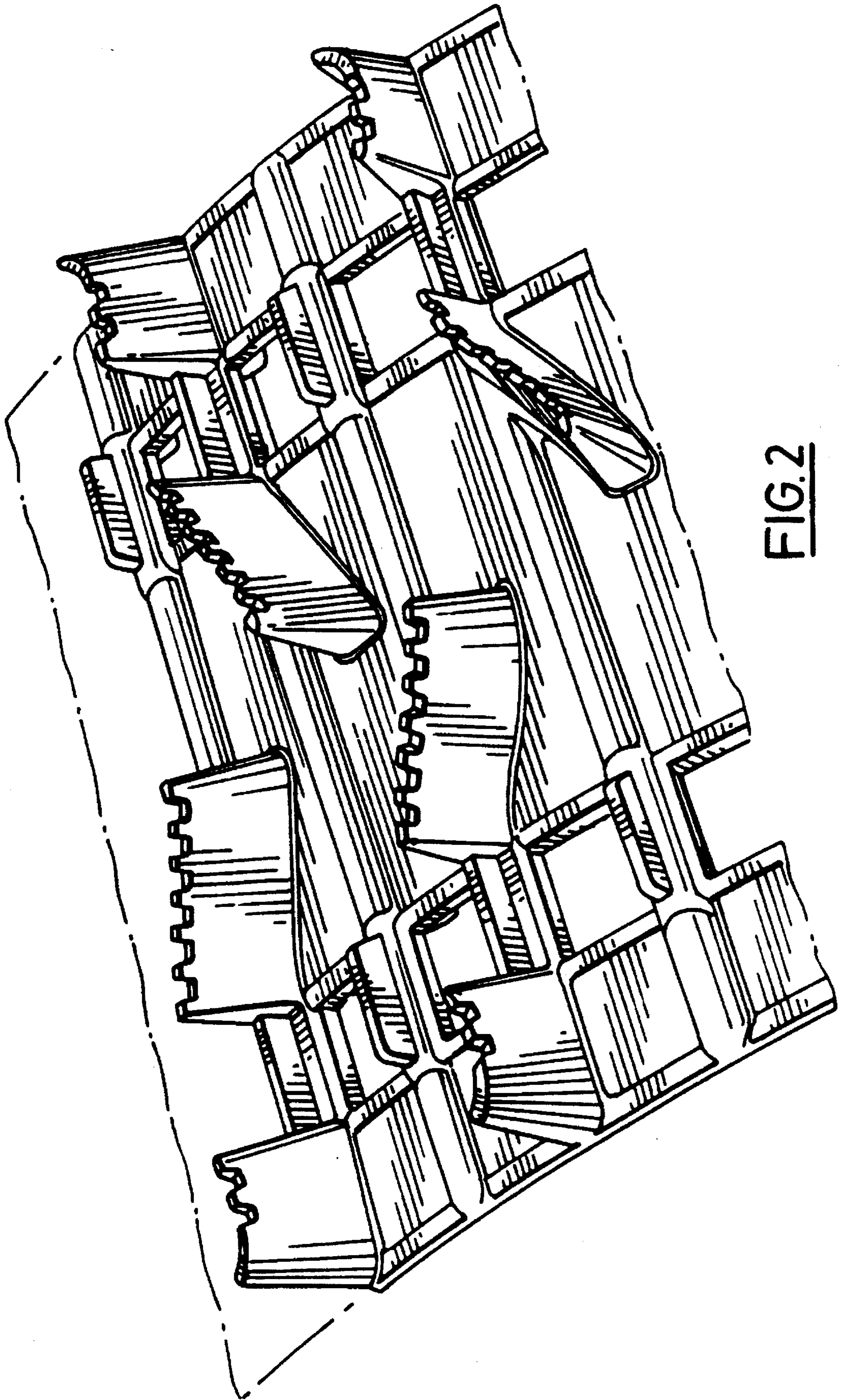

FIG. 2

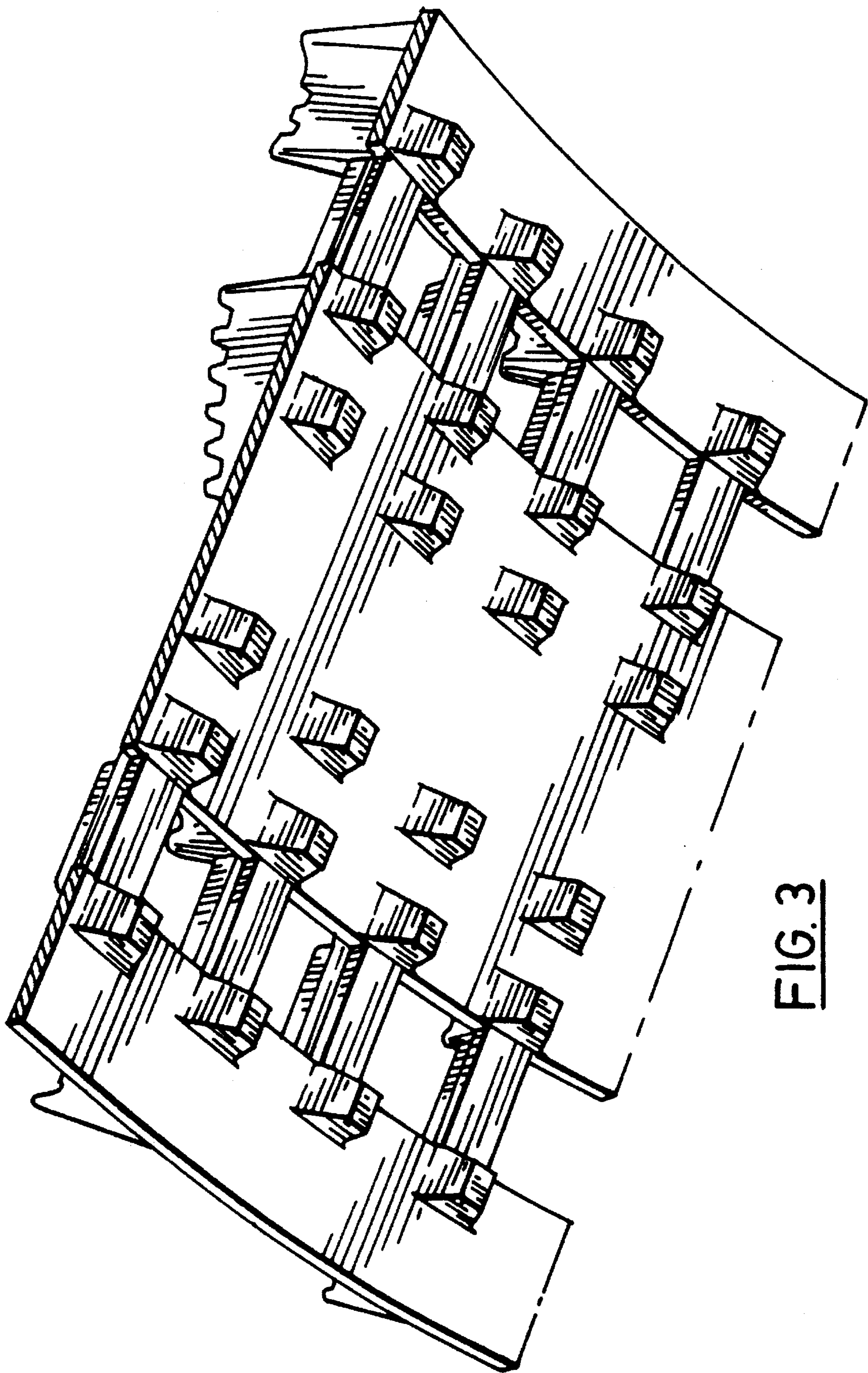

FIG. 3

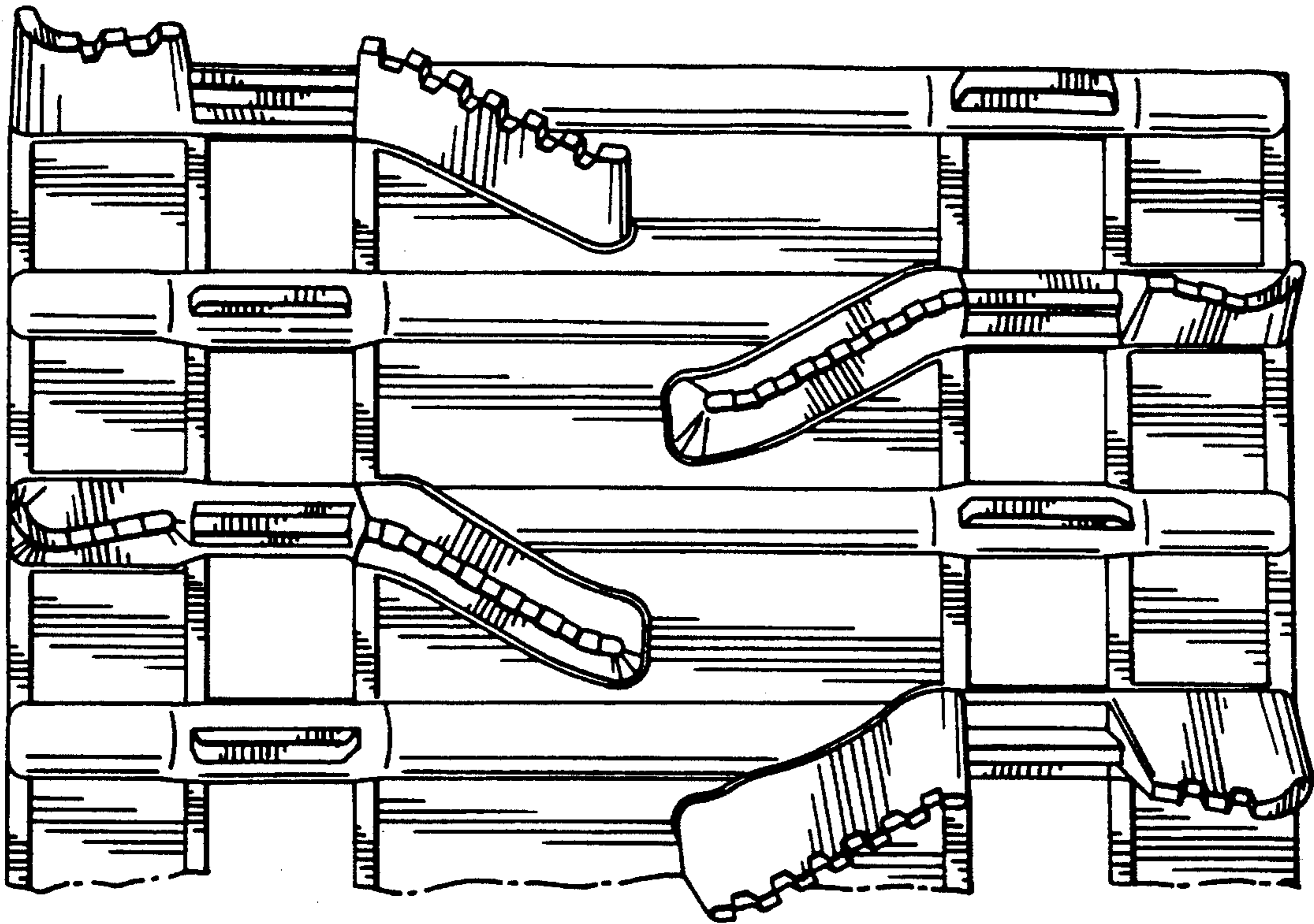

FIG. 4

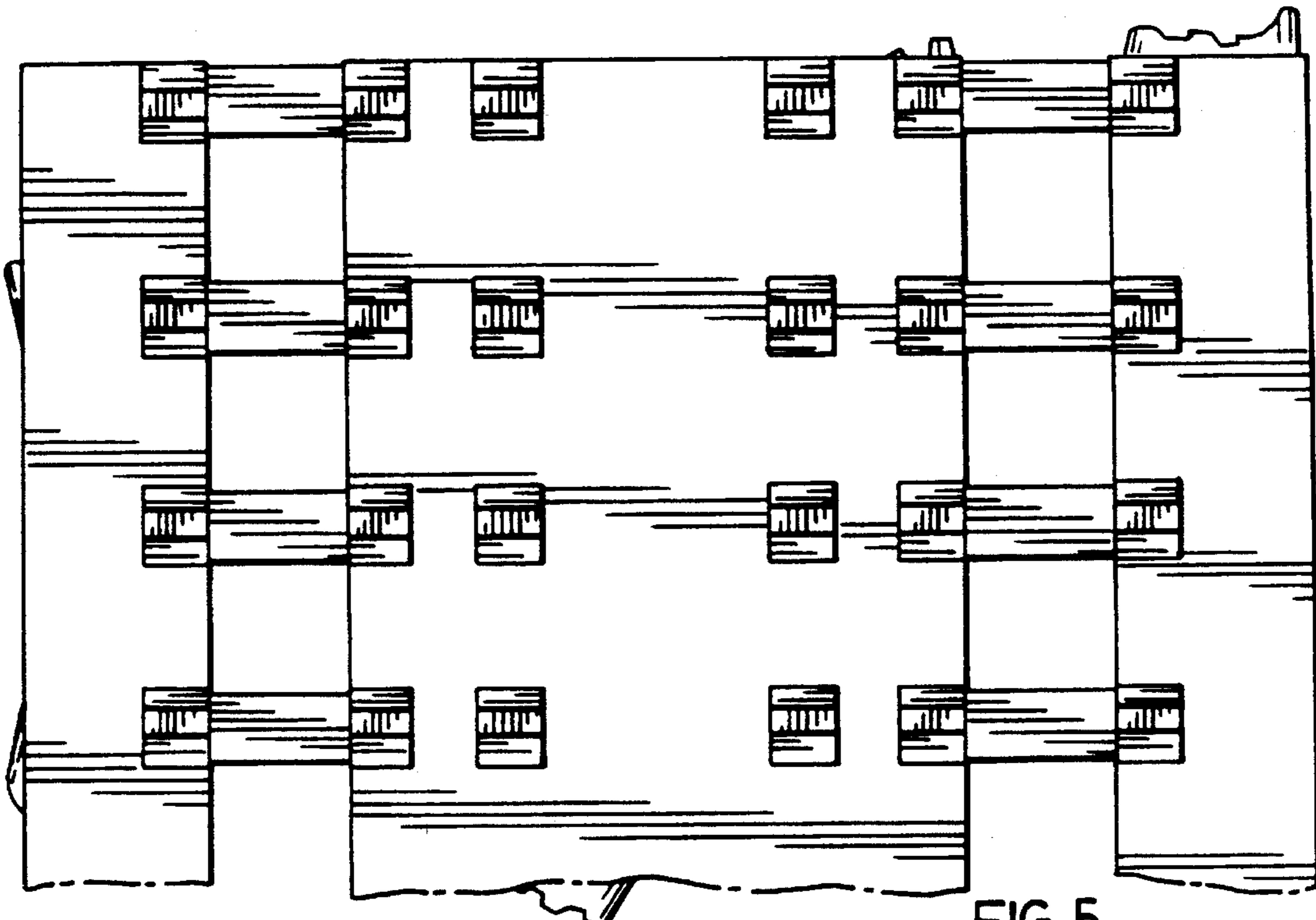

FIG. 5

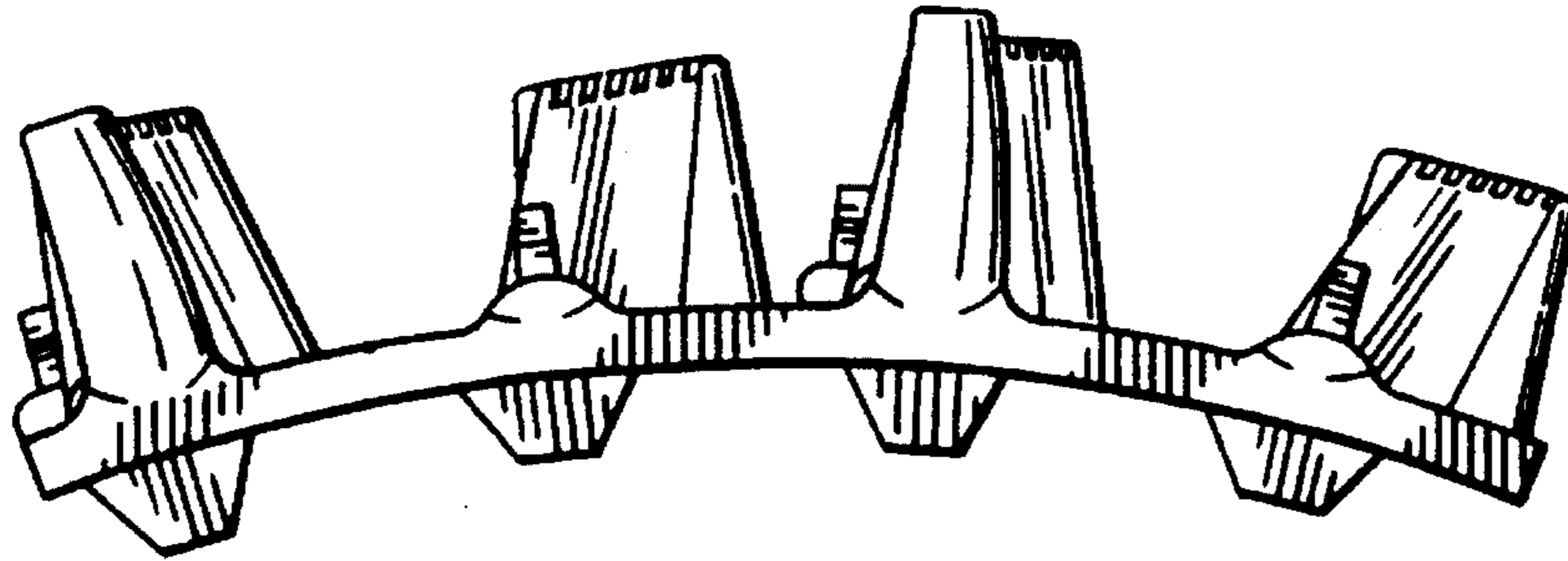

FIG. 6

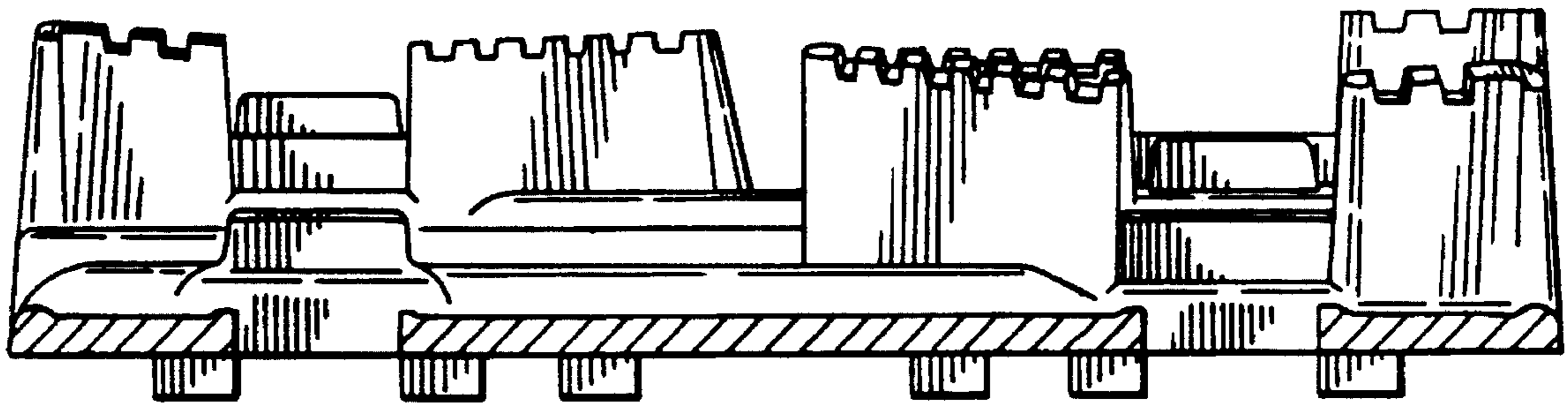

FIG. 7