



US00D376933S

# United States Patent [19] Barnhill

[11] Patent Number: **Des. 376,933**

[45] Date of Patent: **\*\*Dec. 31, 1996**

[54] **PORTABLE KITCHEN CABINET**  
[76] Inventor: **Russell E. Barnhill**, 219 Duerr Dr.,  
Bellville, Tex. 77418  
[\*\*] Term: **14 Years**  
[21] Appl. No.: **39,007**  
[22] Filed: **May 18, 1995**

3,290,105 12/1966 Nall .  
3,543,890 12/1970 Criswell ..... 312/316 X  
3,896,744 6/1973 Goobl .  
3,908,831 9/1975 Brendgord .  
4,131,327 12/1978 Marshall et al. .  
4,189,197 2/1980 Walker, Jr. .  
4,919,109 4/1990 Riley .  
4,919,498 4/1990 Turner .

### Related U.S. Application Data

[63] Continuation-in-part of Ser. No. 57,494, May 6, 1993,  
abandoned.  
[52] U.S. Cl. .... **D6/445**  
[58] Field of Search ..... D6/396, 397, 432-448,  
D6/555, 559, 560, 573; 312/258, 327, 245,  
328, 287, 244, 285, 241, 351.3, 316, 231

### FOREIGN PATENT DOCUMENTS

1314871 12/1962 France .  
840017 4/1952 Germany .  
2142753 3/1973 Germany .  
2504800 8/1976 Germany .

*Primary Examiner*—Carmen H. Vales-Lado  
*Attorney, Agent, or Firm*—Richard C. Litman

### [56] References Cited

#### U.S. PATENT DOCUMENTS

D. 280,156 8/1985 Allen et al. .... D6/432  
D. 350,035 8/1994 Stacey ..... D6/397  
361,667 4/1887 Bearden .  
1,225,958 5/1917 Hopwood .  
1,901,861 3/1933 Baker ..... 312/231  
2,344,800 3/1944 Butcher ..... 312/287 X  
2,575,537 11/1951 Trumfio .  
2,582,812 1/1952 Wise ..... 312/242  
2,615,776 10/1952 Lorentzen .  
2,662,989 12/1953 Thatcher .  
2,944,862 7/1960 Heil .  
2,996,345 8/1961 Gostin .  
3,016,275 1/1962 Grant .  
3,082,050 3/1963 Baxter et al. .  
3,285,685 11/1966 Hewett .

### [57] CLAIM

The ornamental design for a portable kitchen cabinet, as shown and described.

### DESCRIPTION

FIG. 1 is a perspective view of a portable kitchen cabinet showing my new design;  
FIG. 2 is a top view thereof;  
FIG. 3 is a front elevational view thereof;  
FIG. 4 is a left side elevational view as seen when in use;  
FIG. 5 is a right side elevational view as seen when in use; and,  
FIG. 6 is a bottom view thereof.  
The undisclosed rear is plain and unornamented.  
The broken line showing of a table in FIGS. 1 and 5 and of adjustable legs in FIGS. 4 and 6 are for illustrative purposes only and forms no part of the claimed design.

**1 Claim, 6 Drawing Sheets**

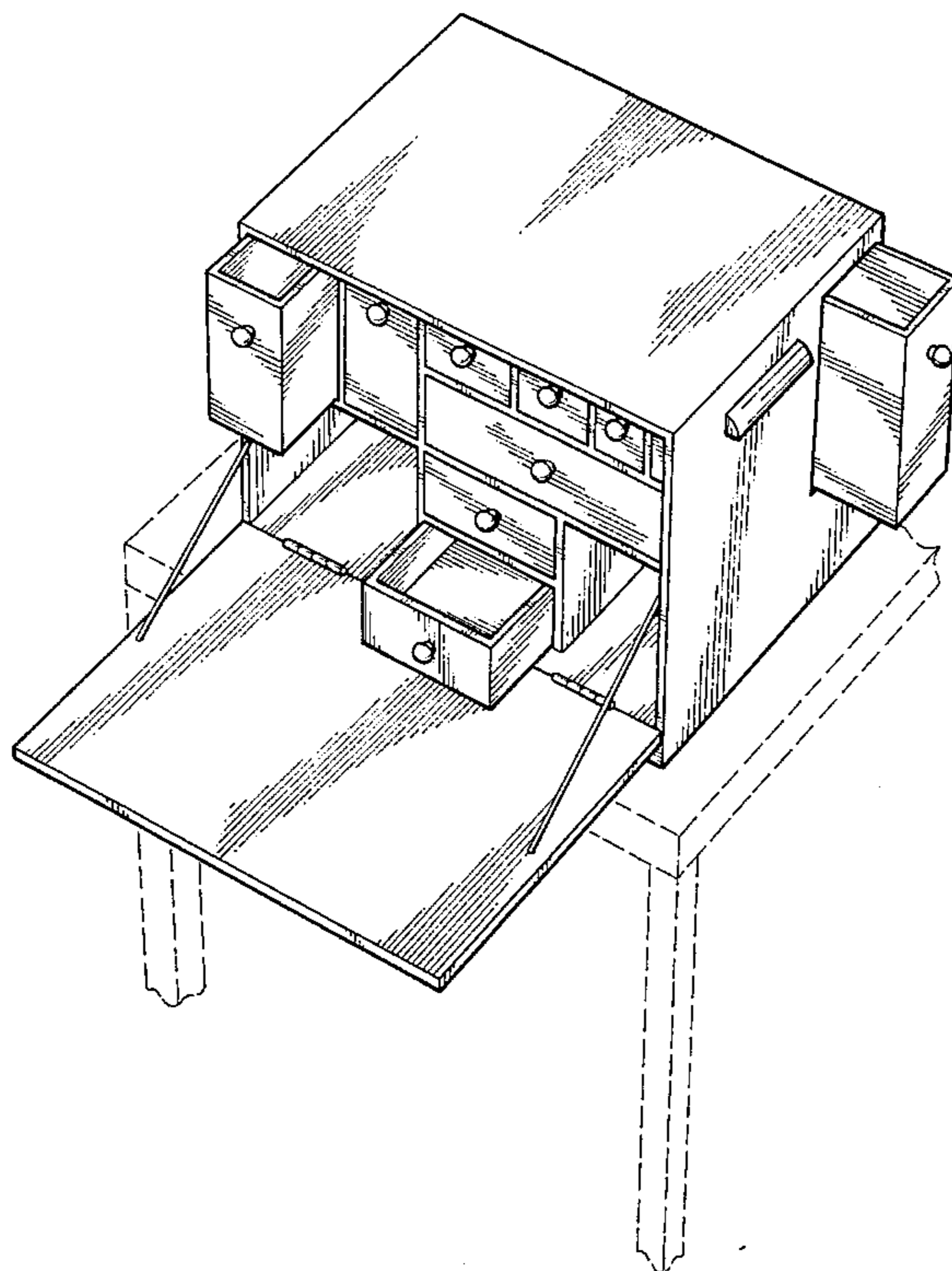

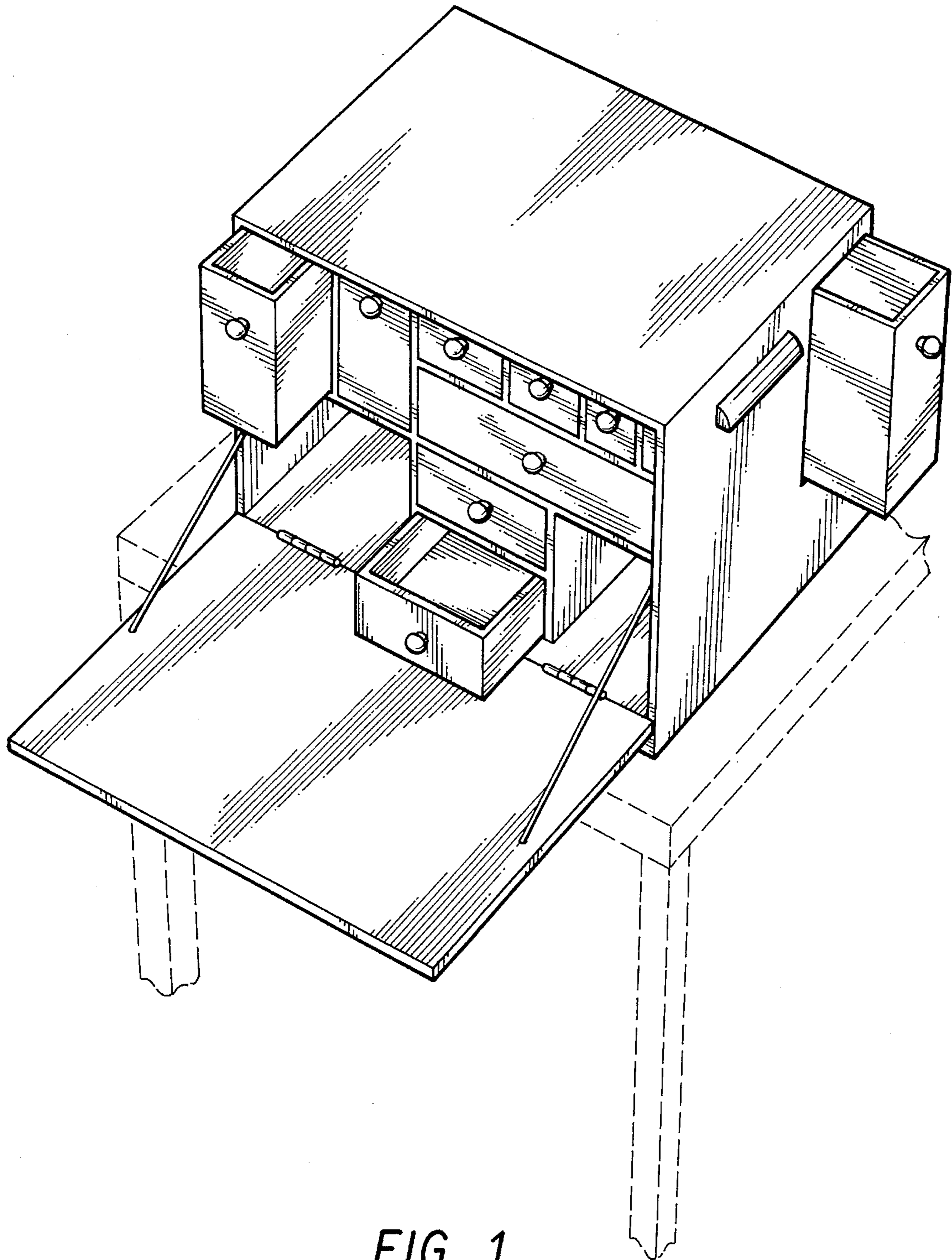

FIG. 1

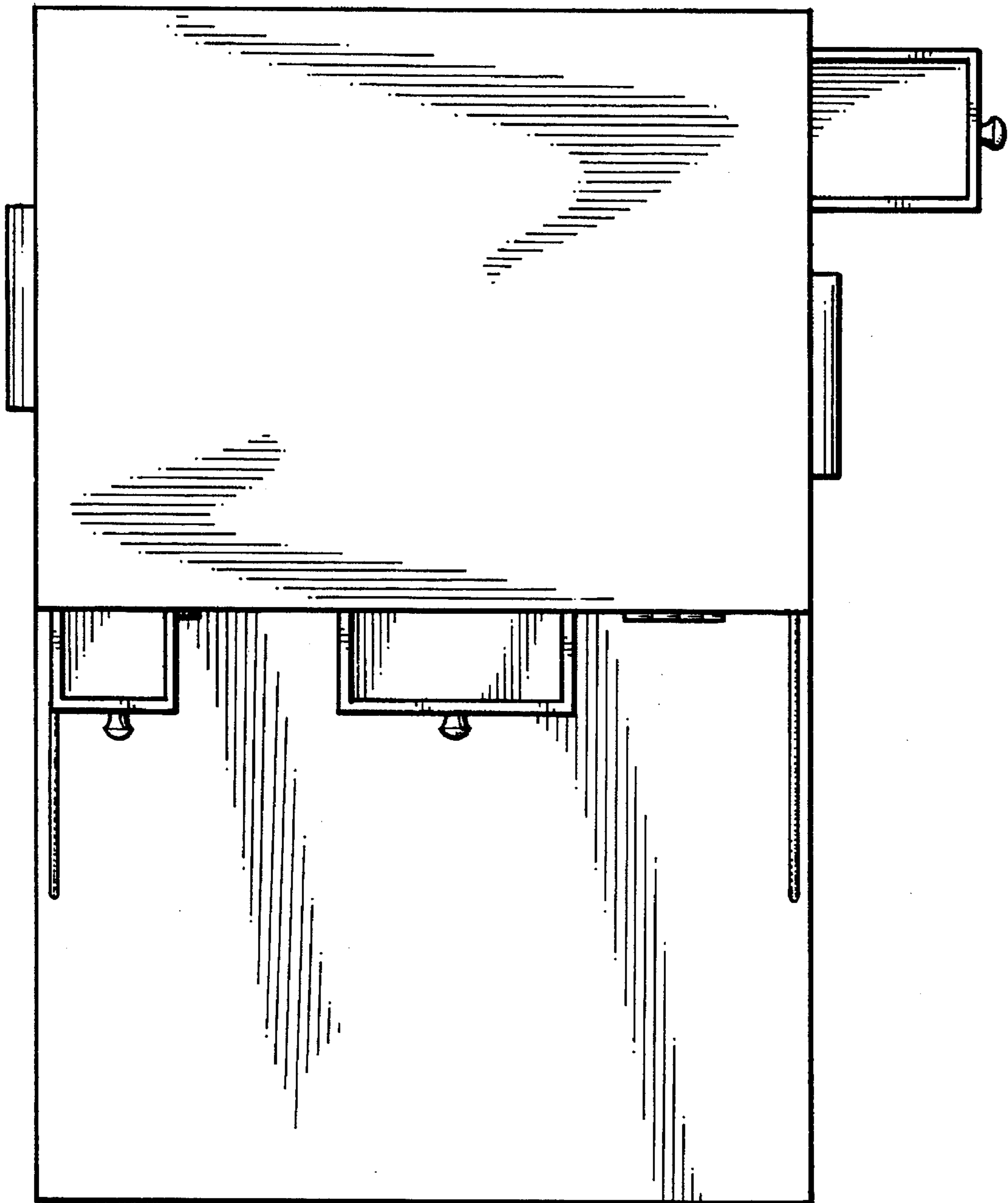

FIG. 2

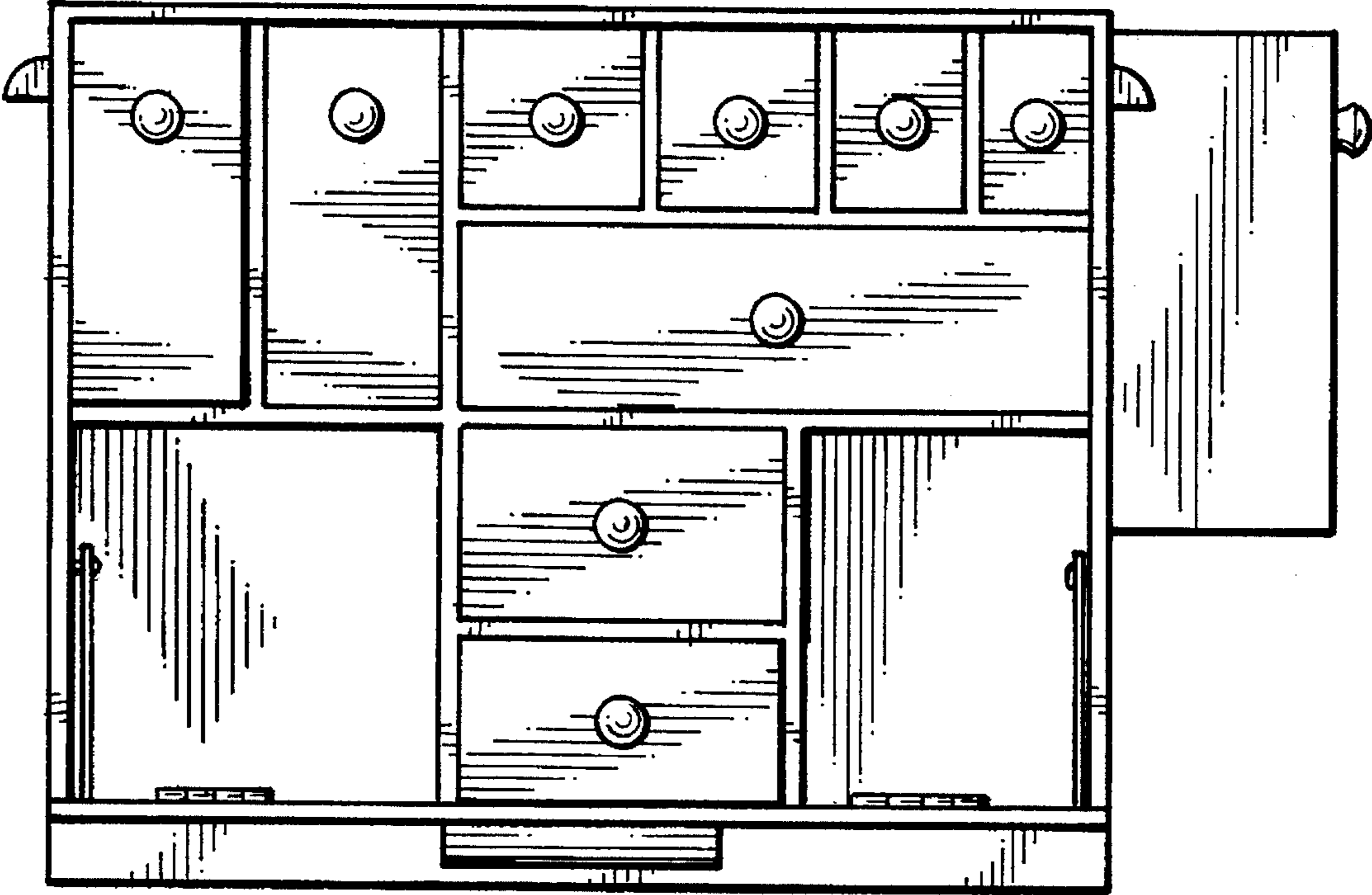

FIG. 3

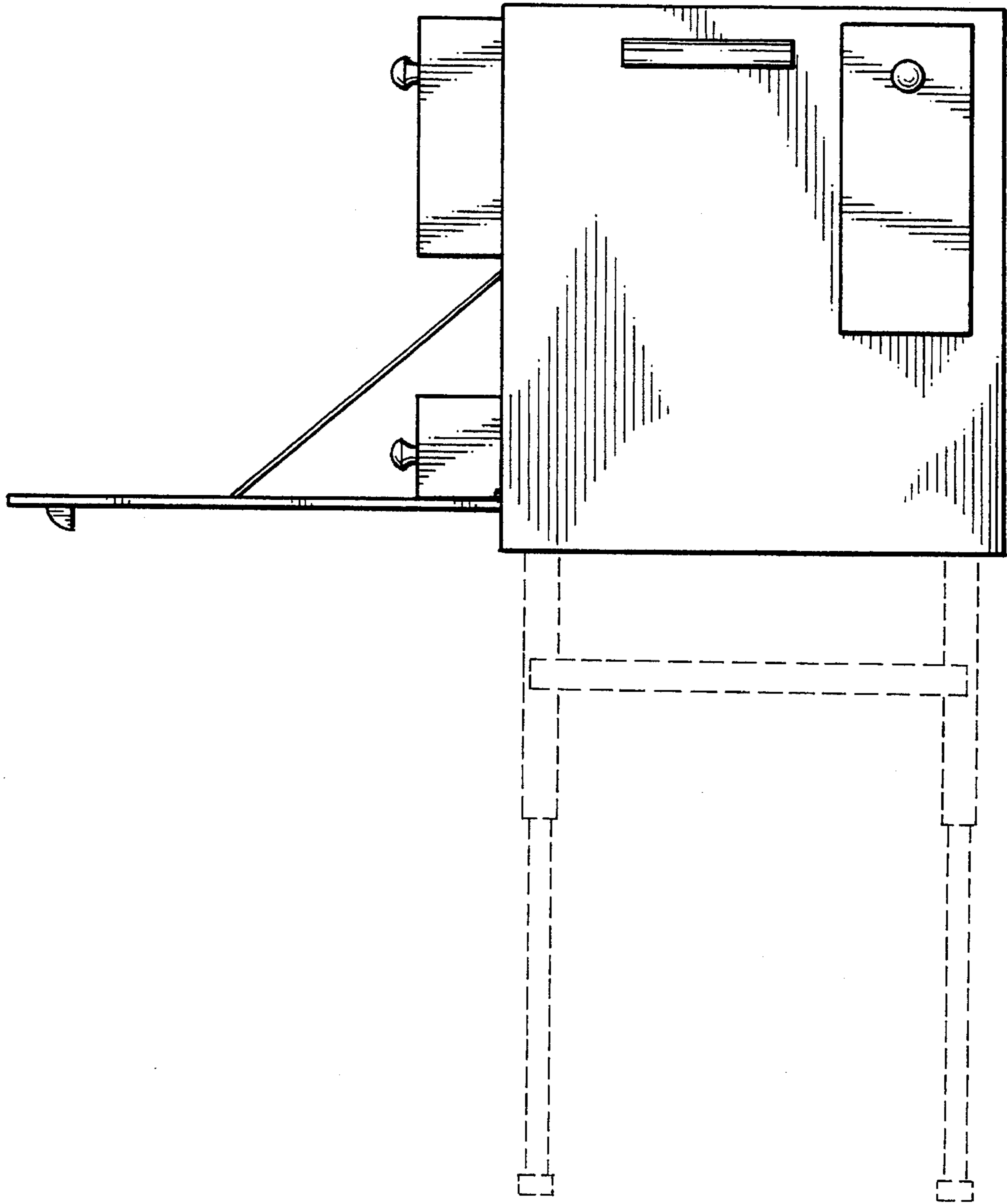

FIG. 4

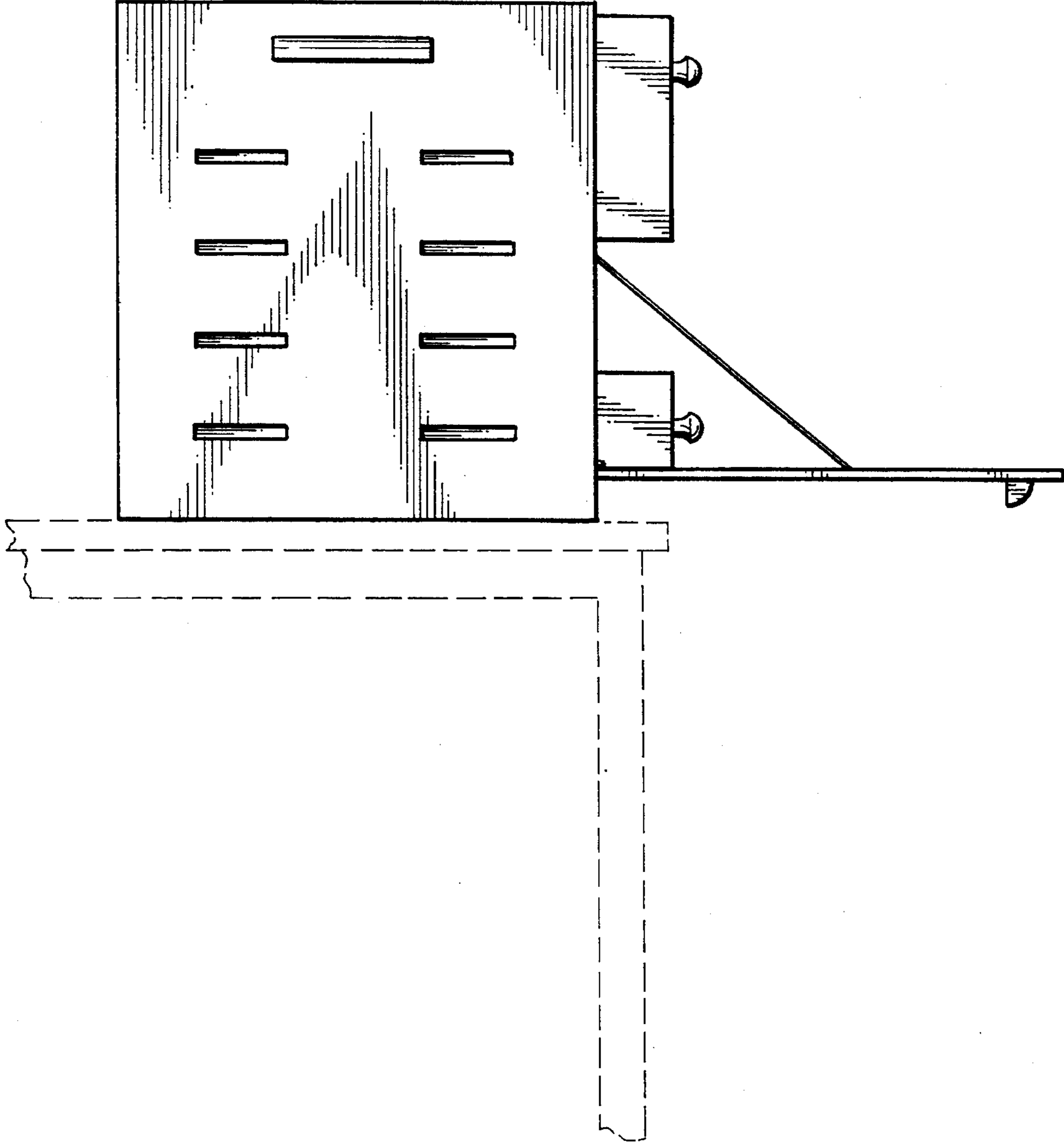

FIG. 5

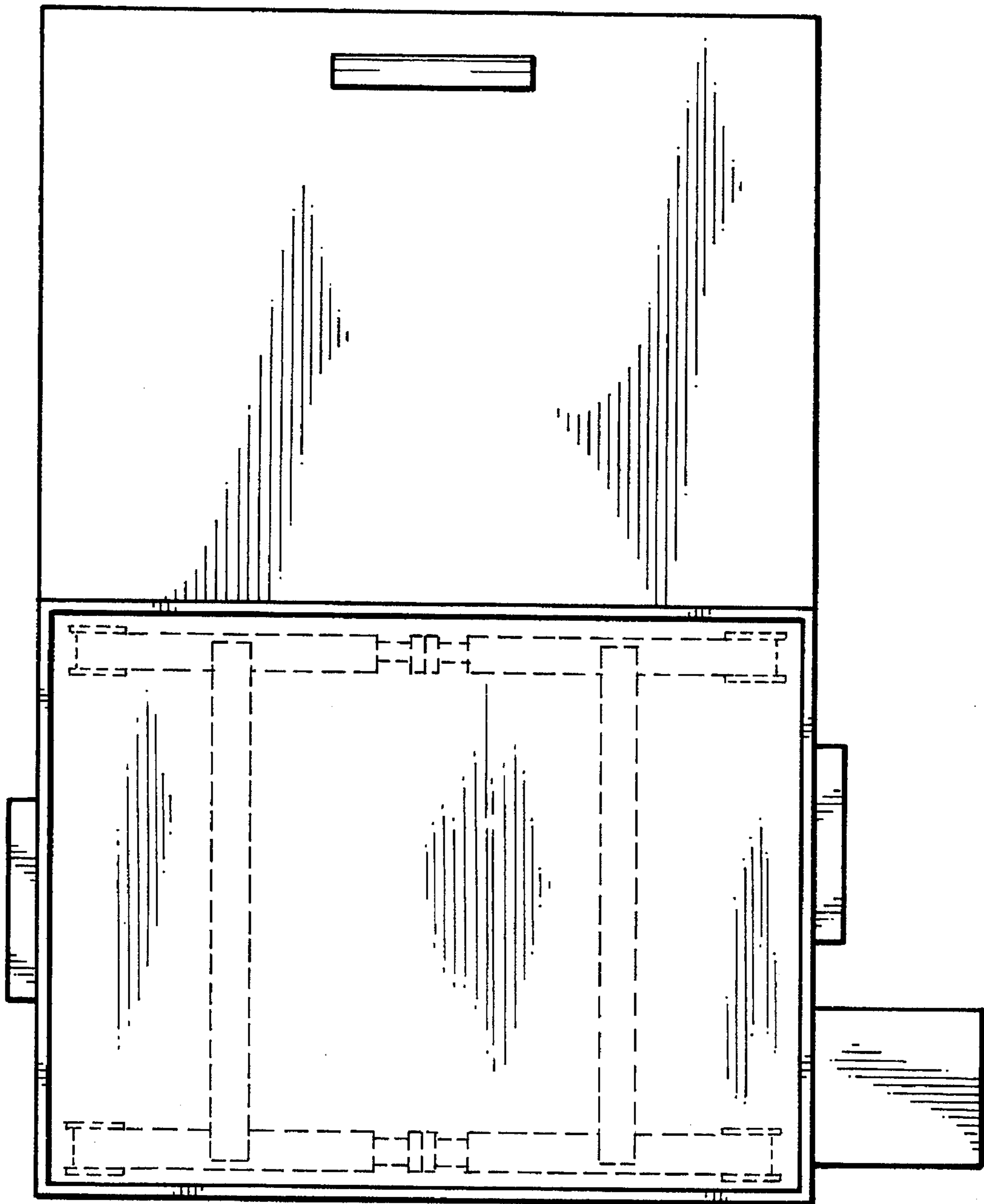

FIG. 6