



US00D376865S

United States Patent [19]

Chan

[11] Patent Number: **Des. 376,865**

[45] Date of Patent: ****Dec. 24, 1996**

[54] **CLAMP-ON LAMP**

[75] Inventor: **Kam-Hoi Chan**, Shatin, Hong Kong

[73] Assignee: **Go-Gro Industries, Ltd.**, Kowloon Bay, Hong Kong

[**] Term: **14 Years**

[21] Appl. No.: **49,370**

[22] Filed: **Jan. 24, 1996**

[52] U.S. Cl. **D26/60; D26/63**

[58] Field of Search **D26/60, 61, 62, D26/63, 65; 362/147, 269, 275, 287, 418, 419, 427, 404, 396**

[56] **References Cited**

U.S. PATENT DOCUMENTS

D. 117,474 11/1939 Grode D26/60

OTHER PUBLICATIONS

Electrix Halogens Task Lighting Catalog, May-1987, p. 13, Universal Clip halogen #7020.

B. A. Pargh Co. Spring & Summer Catalog, 1985, p. 93, Clip-on Spotlight.

Hong Kong Enterprise, Jun.-1991, p. 290, Clip-on Spotlight.

Primary Examiner—Susan J. Lucas
Attorney, Agent, or Firm—Merchant, Gould, Smith, Edell, Welter & Schmidt, P.A.

[57] **CLAIM**

The ornamental design for a clamp-on lamp, as shown and described.

DESCRIPTION

FIG. 1 is a perspective view of a clamp-on lamp showing my new design;

FIG. 2 is a front elevational view thereof, the rear being a mirror image;

FIG. 3 is a right side elevational view thereof;

FIG. 4 is a left side elevational view thereof;

FIG. 5 is a top plan view thereof; and,

FIG. 6 is a bottom plan view thereof.

1 Claim, 6 Drawing Sheets

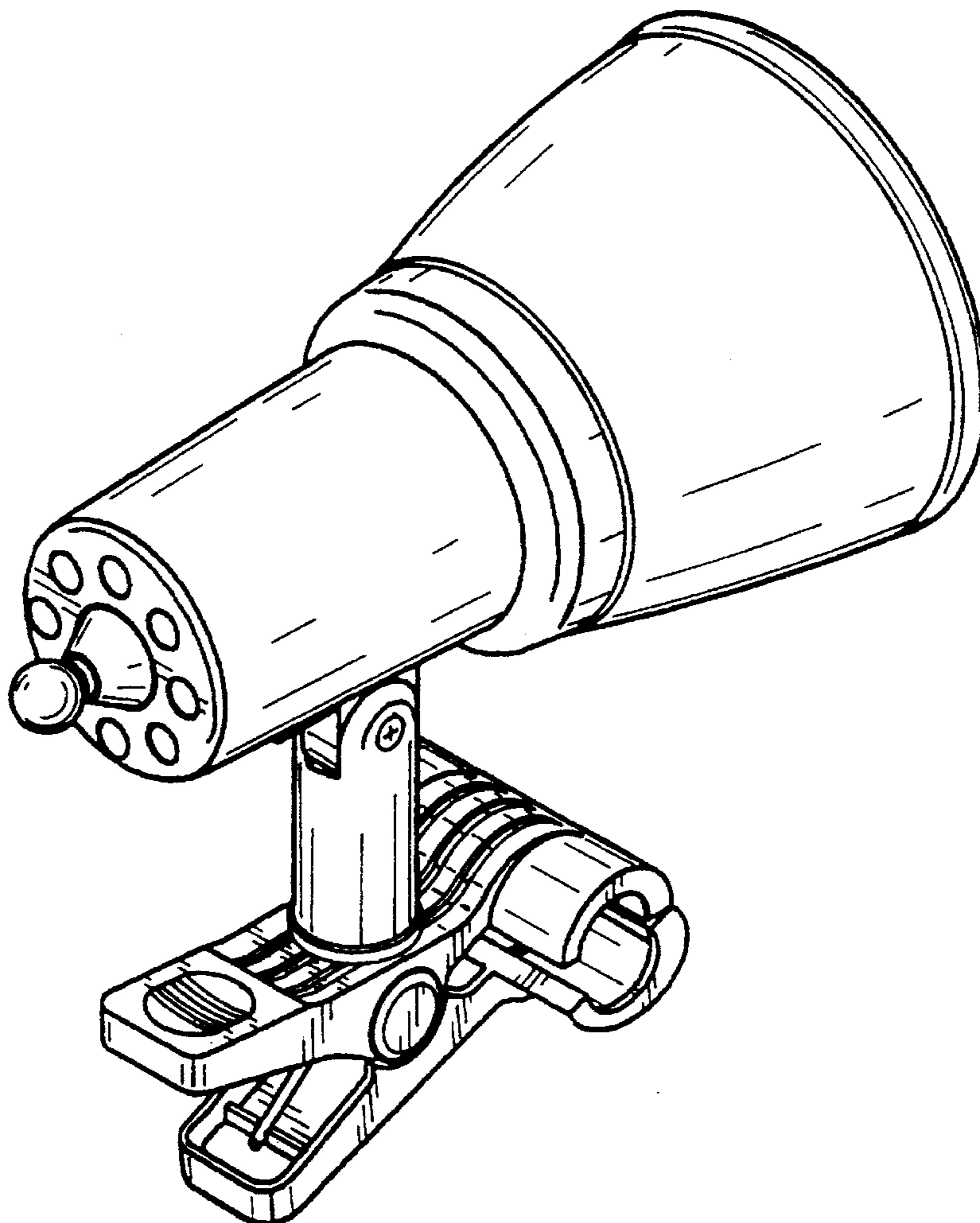

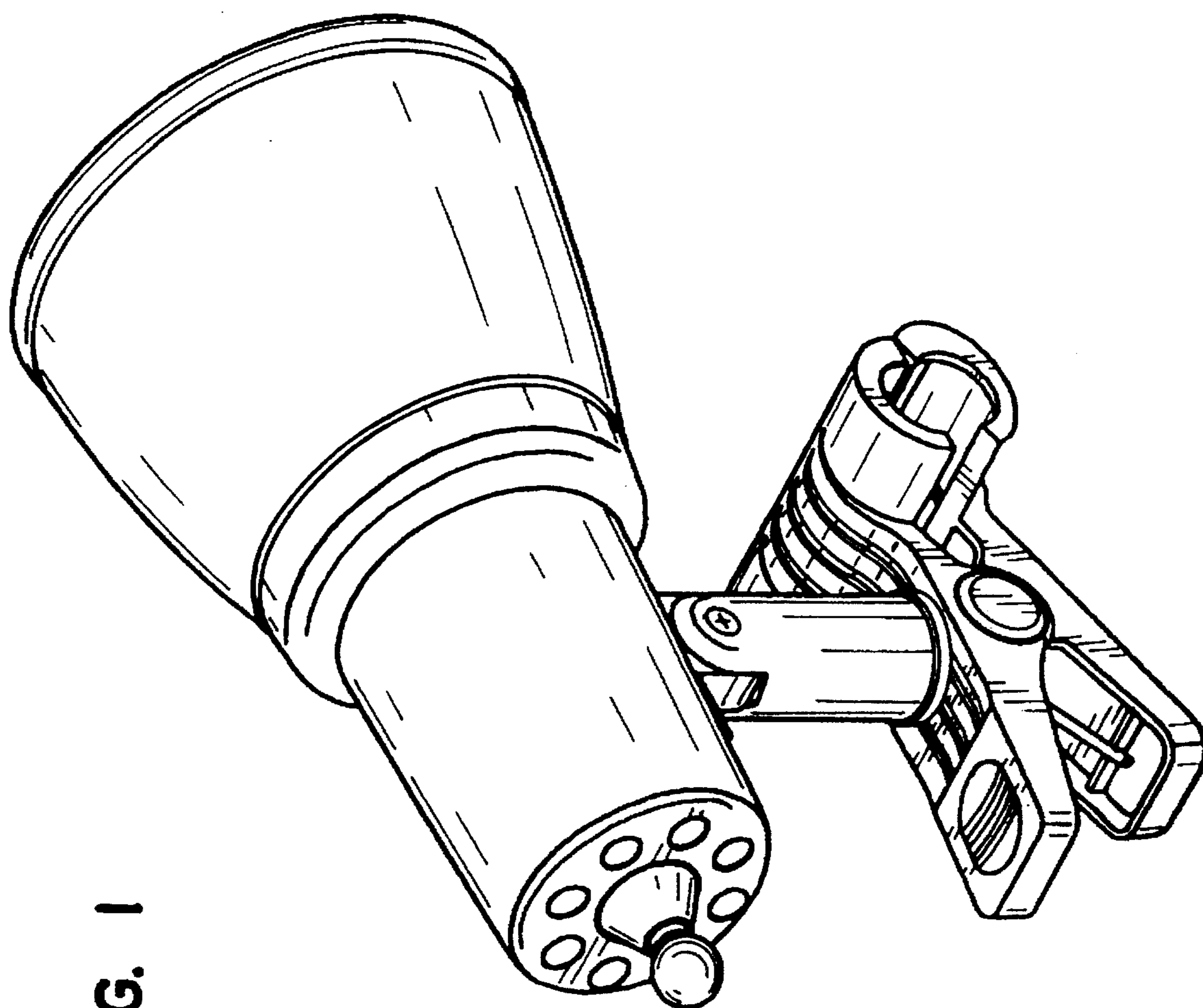

FIG. 1

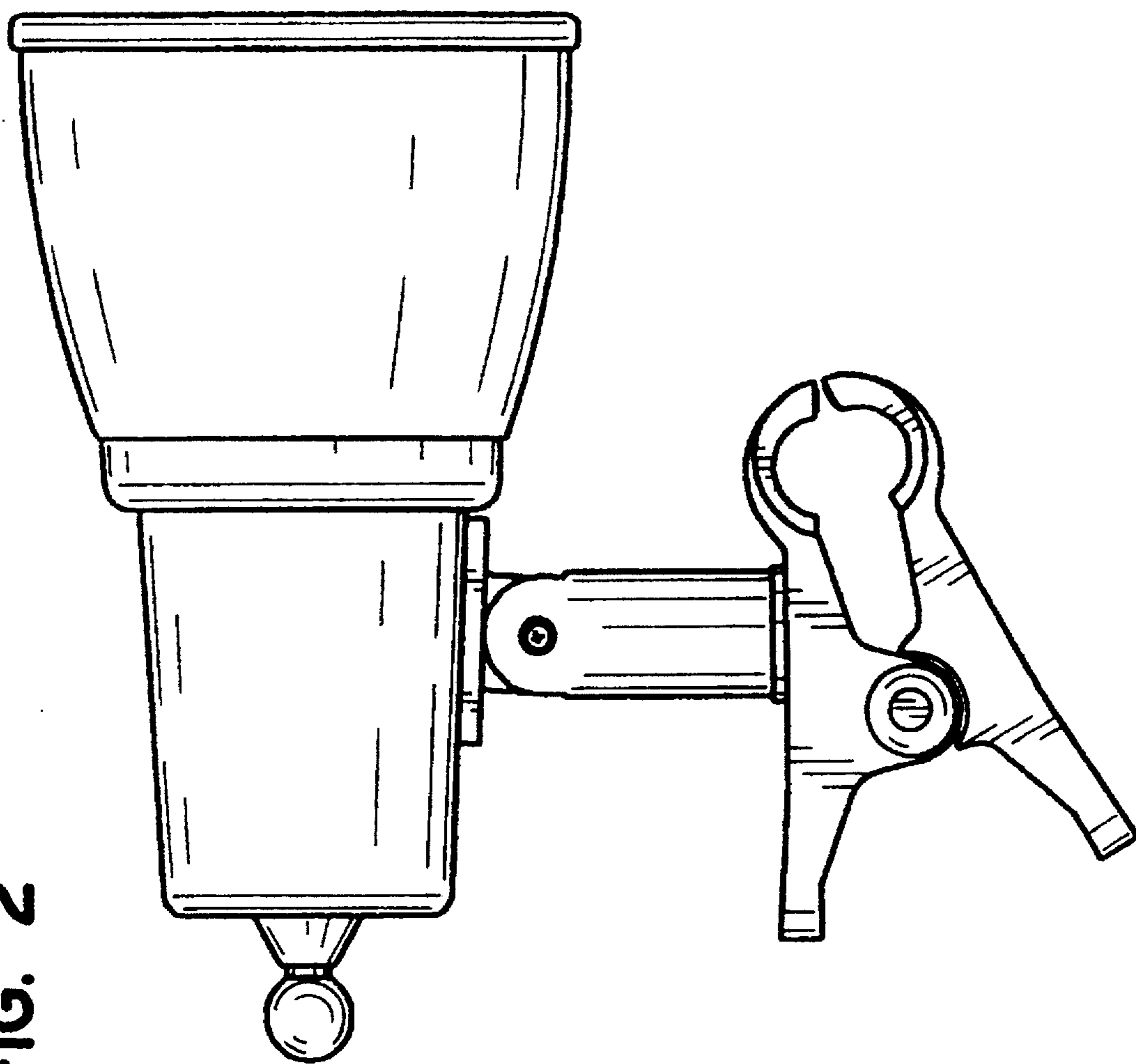

FIG. 2

FIG. 3

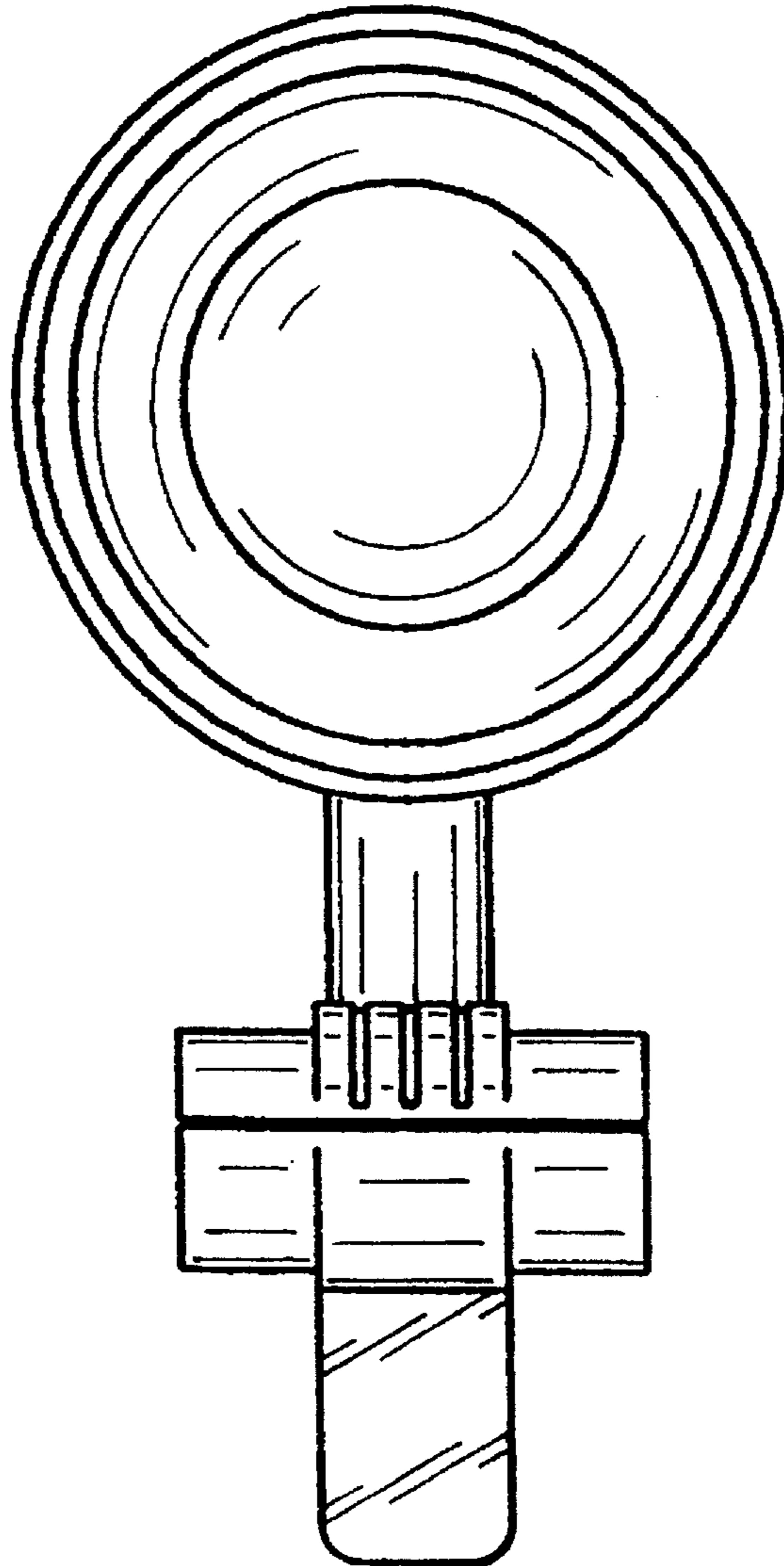
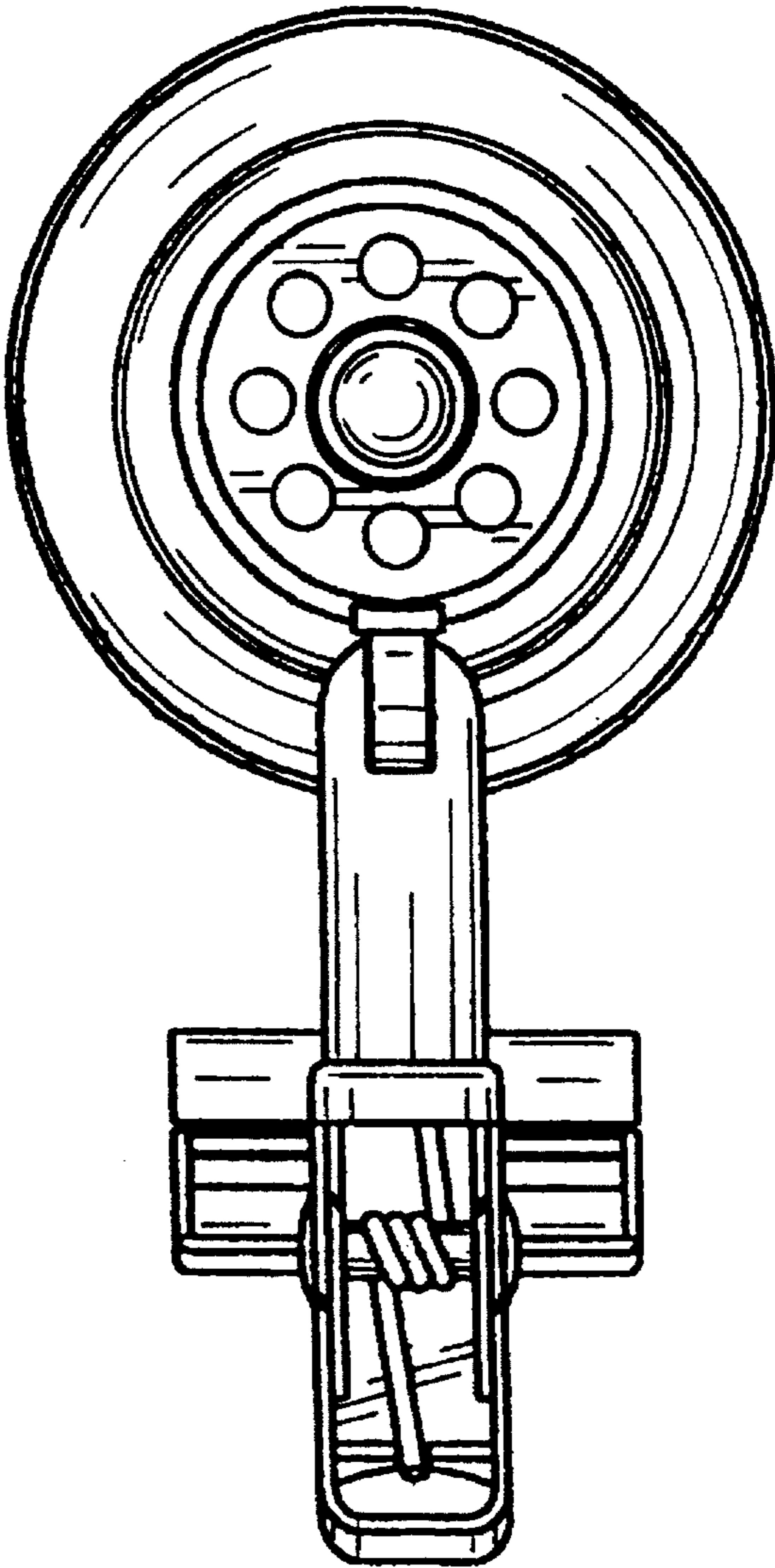

FIG. 4



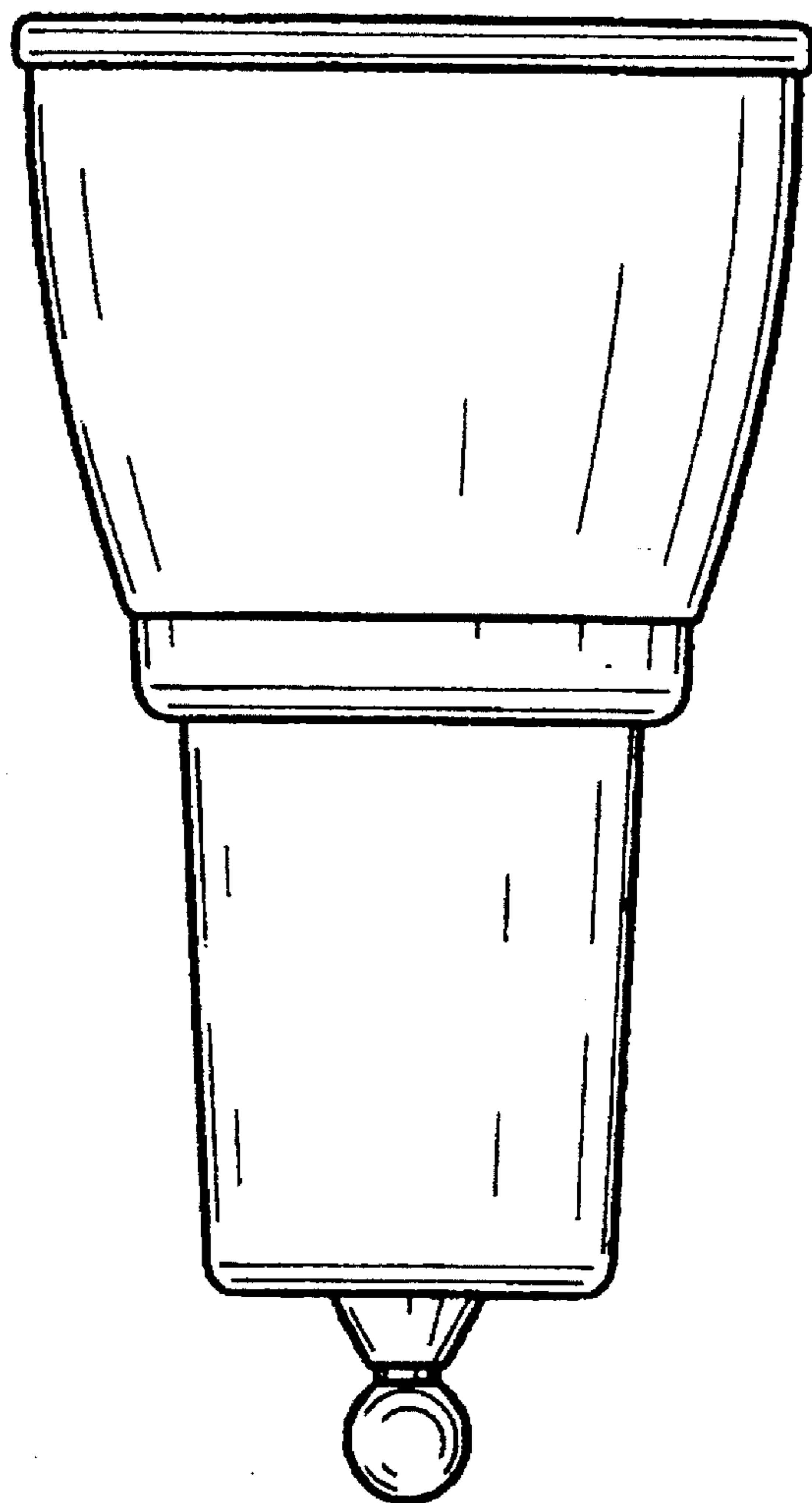

FIG. 5

FIG. 6

