



US00D376782S

United States Patent [19]

Kincart

[11] Patent Number: **Des. 376,782**

[45] Date of Patent: ****Dec. 24, 1996**

[54] **EXTENDED VEHICLE BRUSHGUARD**

4,671,552	6/1987	Anderson	293/144
5,215,343	6/1993	Fortune	293/115
5,277,465	1/1994	Weir	293/144

[76] Inventor: **Mark S. Kincart**, 19511 N. 53rd Dr., Glendale, Ariz. 85308

[**] Term: **14 Years**

Primary Examiner—A. Hugo Word
Assistant Examiner—Melody Brown
Attorney, Agent, or Firm—Laura J. Zeman

[21] Appl. No.: **49,286**

[22] Filed: **Jan. 22, 1996**

[52] U.S. Cl. **D12/171**

[58] Field of Search D12/171, 107,
D12/407, 167; 293/38, 115, 144; 180/215,
233; 224/42.31

[57] CLAIM

The ornamental design for an extended vehicle brushguard, as shown and described.

DESCRIPTION

FIG. 1 is a perspective view of the extended vehicle brushguard showing my new design;
FIG. 2 is a side elevational view thereof;
FIG. 3 is a top plan view thereof;
FIG. 4 is a front elevational view thereof;
FIG. 5 is a bottom plan view thereof; and,
FIG. 6 is a rear elevational view thereof.
The broken lines shown in FIGS. 1 and 2 are for illustrative purposes only and form no part of the claimed design.

[56] References Cited

U.S. PATENT DOCUMENTS

D. 300,420	3/1989	Trinnaman	D12/171
D. 333,457	2/1993	LaFoe et al.	D12/171
D. 361,316	8/1995	Orth, Sr. et al.	D12/171
D. 363,267	10/1995	Gustavsen	D12/107
2,314,600	3/1943	Reyburn	293/144
3,431,005	3/1969	Preifert	293/144
3,438,667	4/1969	Davis	293/144
4,469,360	9/1984	Drury	293/144

1 Claim, 2 Drawing Sheets

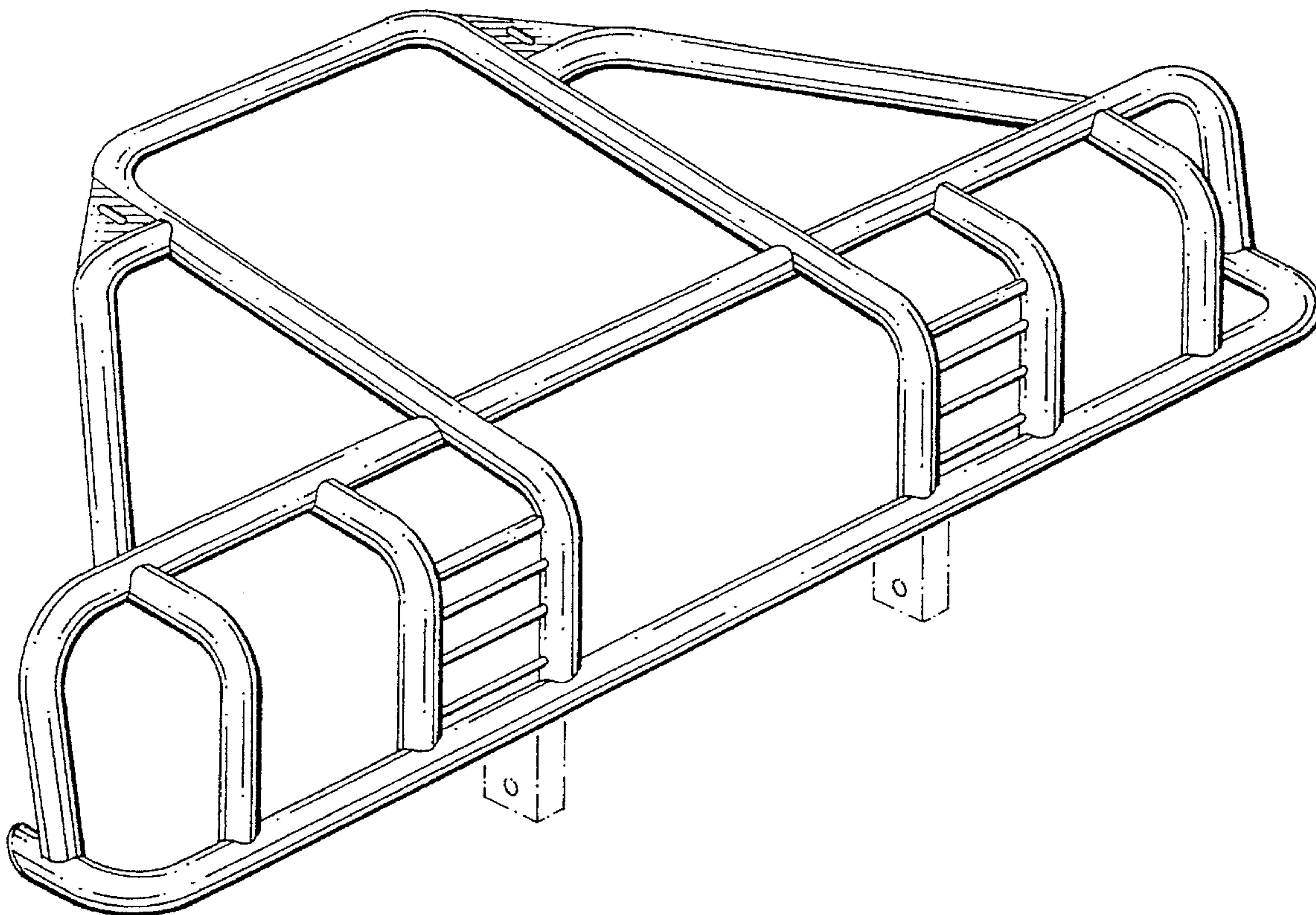

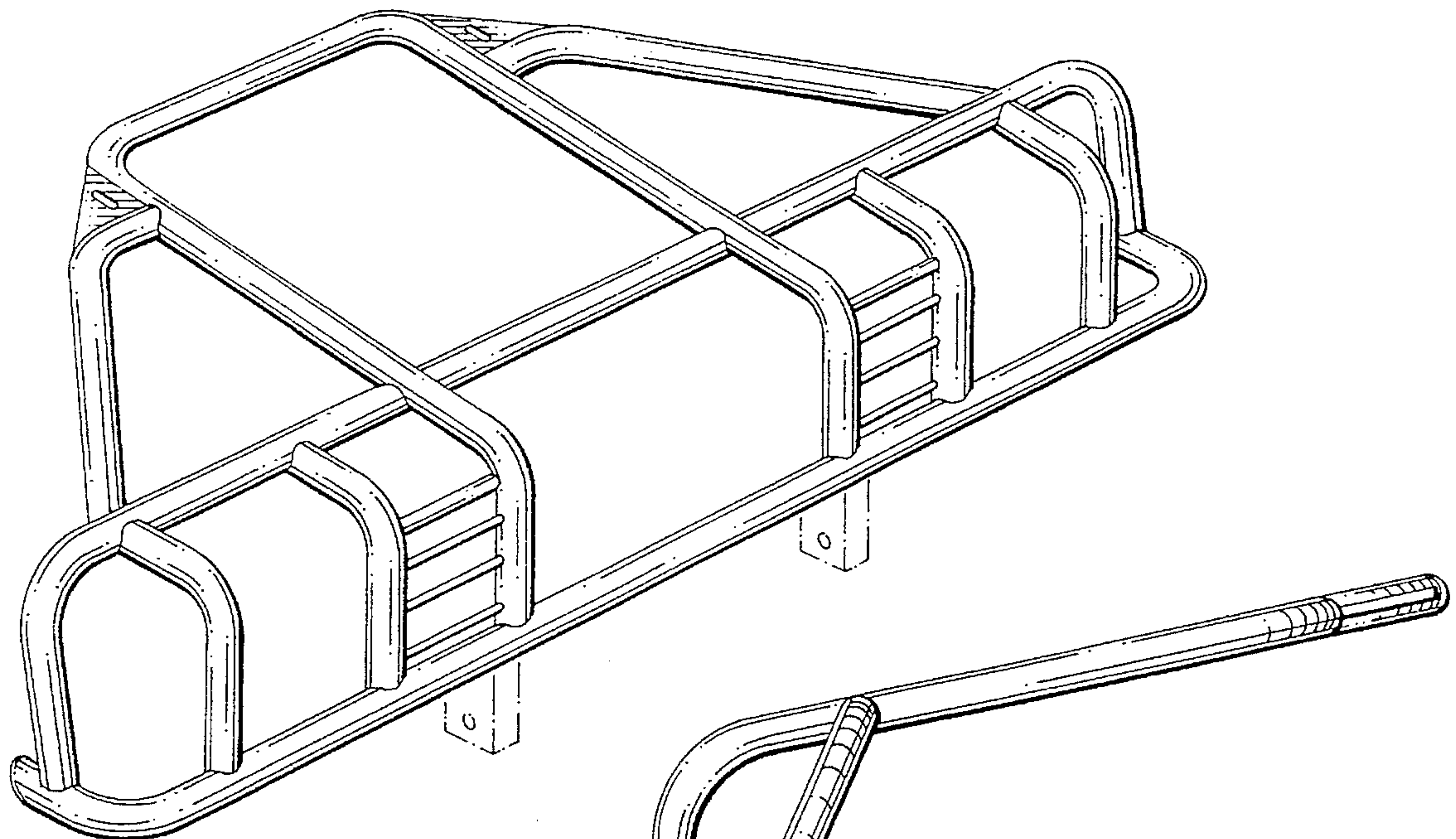

FIG. 1

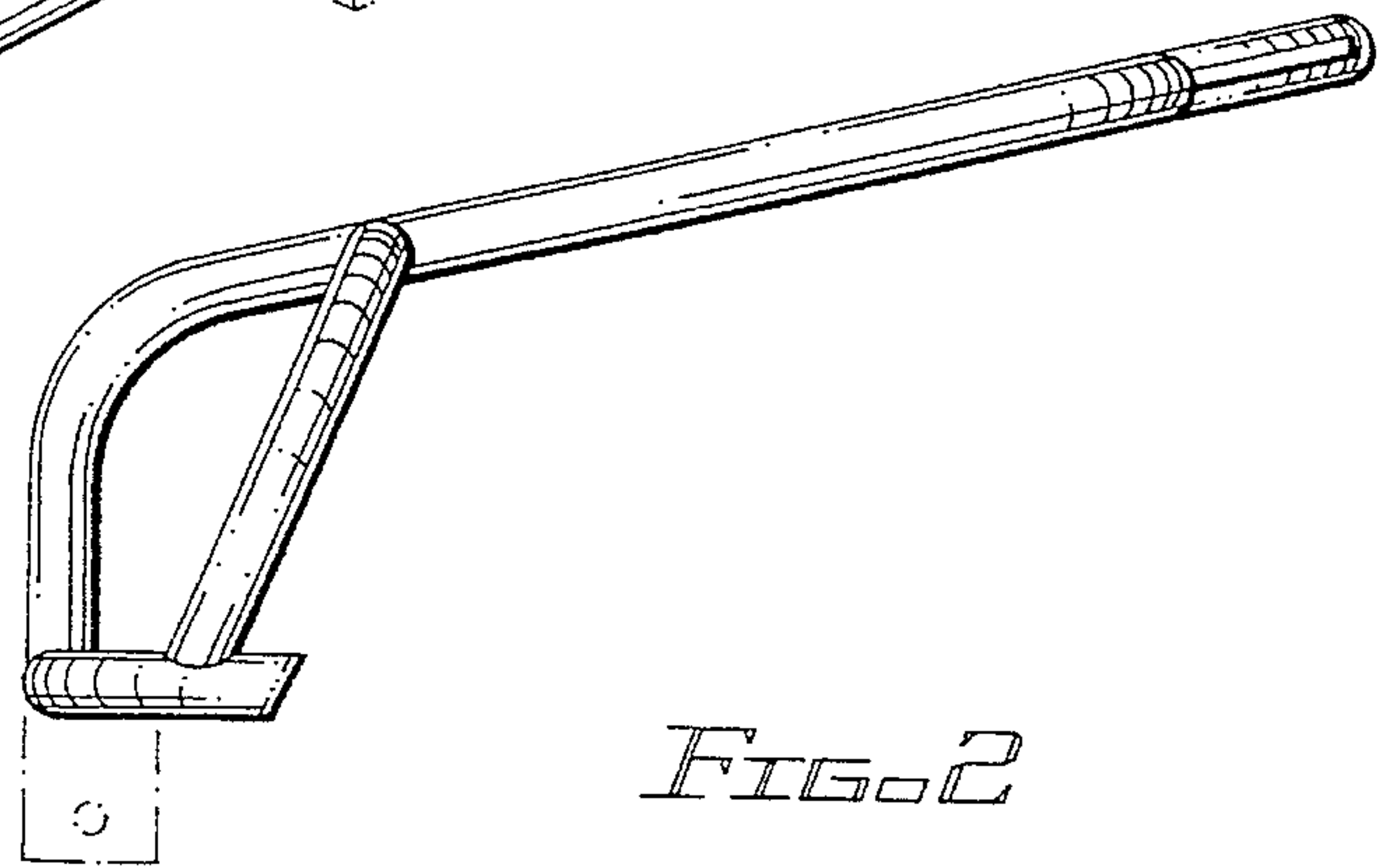

FIG. 2

FIG. 3

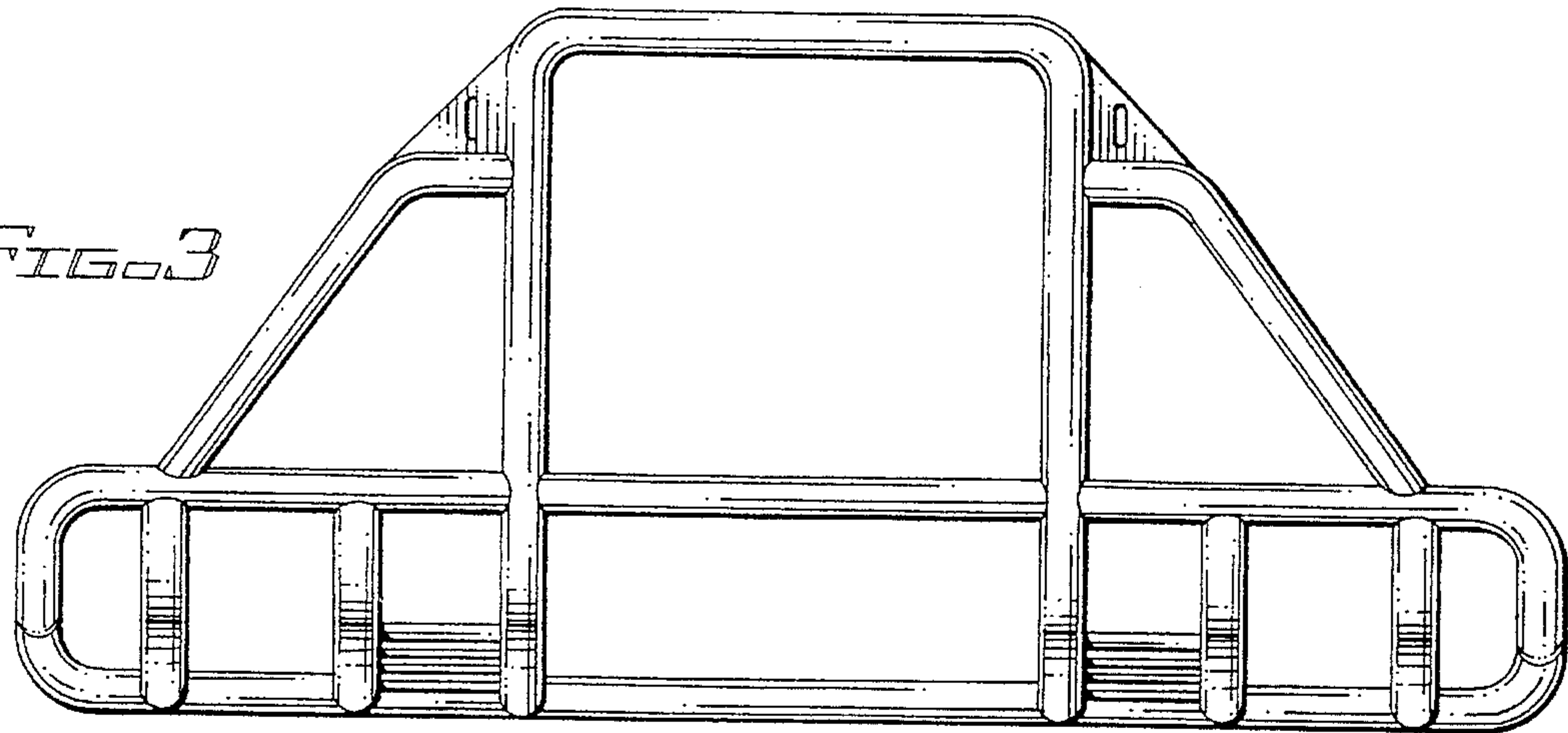
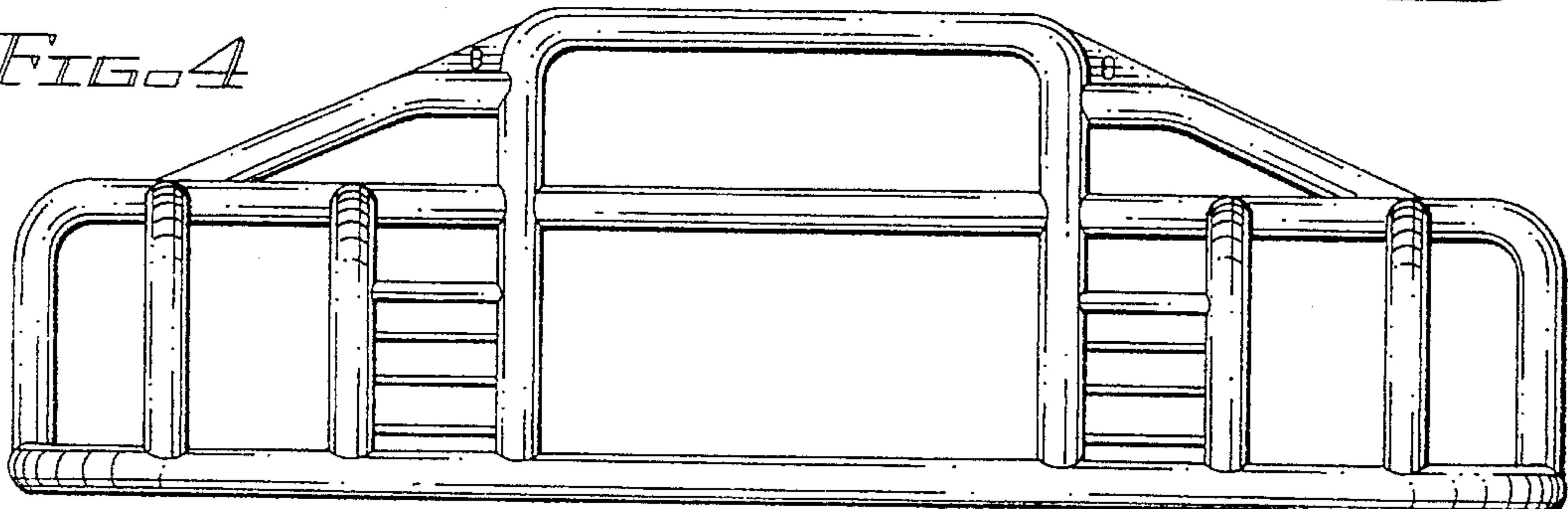

FIG. 4



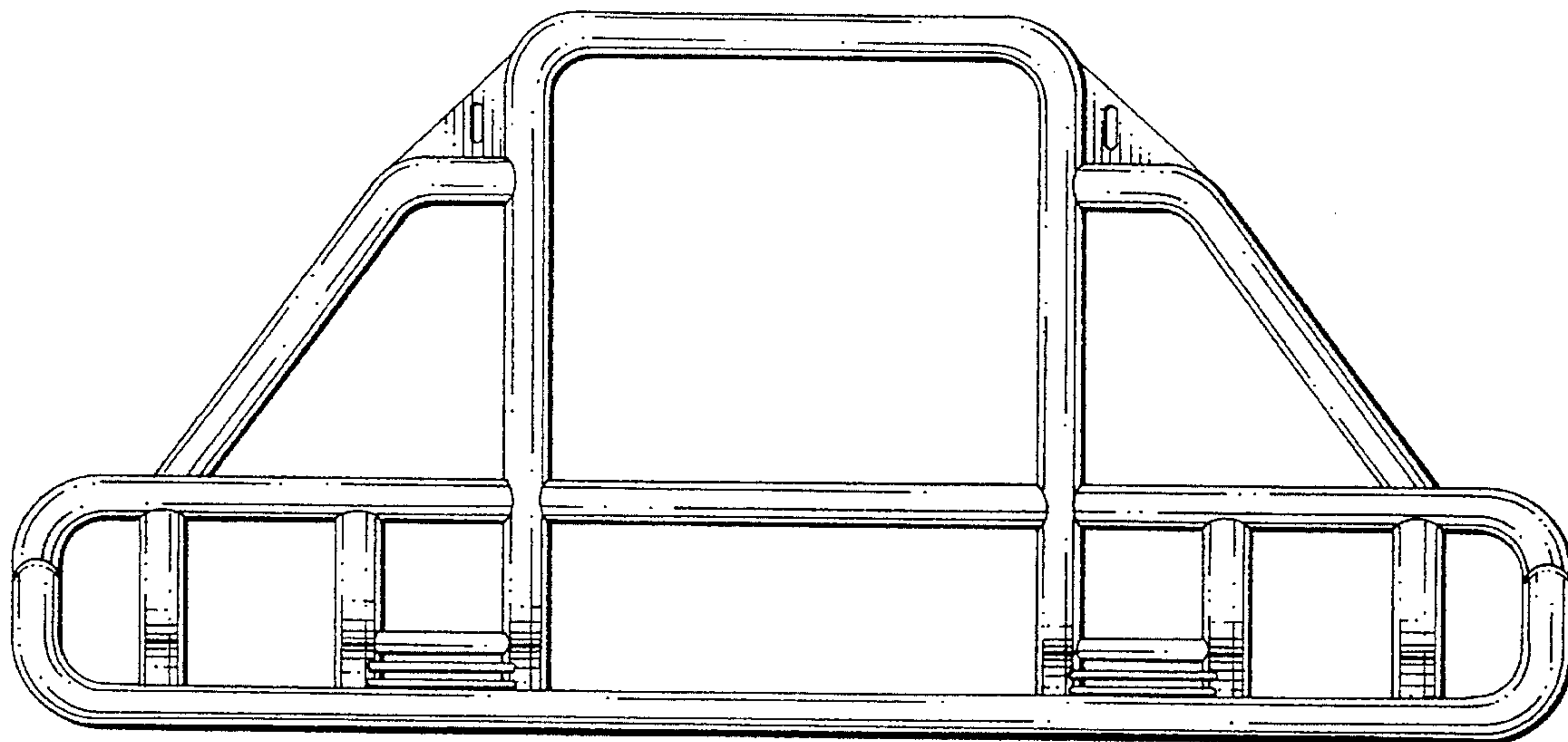

FIG. 5

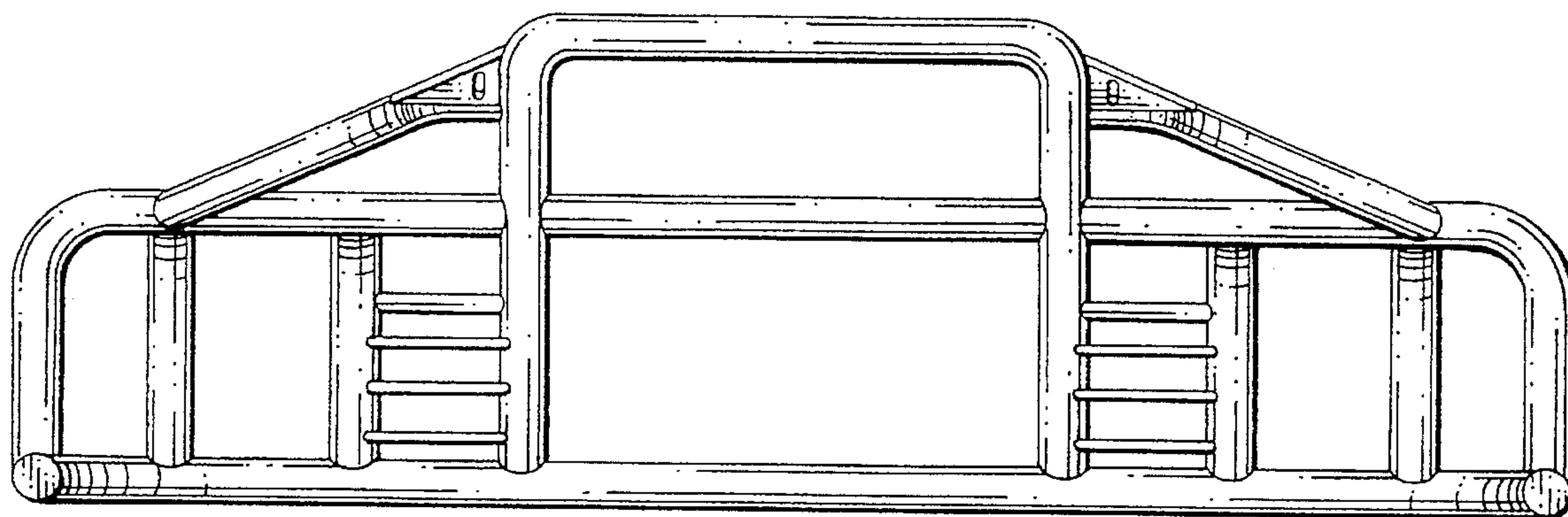

FIG. 6