



US00D376774S

United States Patent [19]

Shikado et al.

[11] Patent Number: **Des. 376,774**

[45] Date of Patent: ****Dec. 24, 1996**

[54] **VEHICLE TRAILER BODY**

[75] Inventors: **Osamu Shikado**, Rochester Hills;
Thomas C. Slanec, Grosse Pointe Woods;
John E. Crain, Birmingham, all of Mich.

[73] Assignee: **Chrysler Corporation**, Auburn Hills, Mich.

[**] Term: **14 Years**

[21] Appl. No.: **48,077**

[22] Filed: **Dec. 19, 1995**

[52] U.S. Cl. **D12/102**

[58] Field of Search D12/101, 86, 102,
D12/105; 280/418.1, 491.1, 482; 296/181,
24.1

[56] **References Cited**

U.S. PATENT DOCUMENTS

- D. 231,917 6/1974 Noruki et al. D12/102
- D. 259,037 4/1981 Deardorff D12/102

- D. 310,982 10/1990 Badsey D12/102
- D. 318,841 8/1991 Lemue D12/102
- D. 367,248 2/1996 Christensen D12/102

Primary Examiner—Melody N. Brown
Attorney, Agent, or Firm—Mark P. Calcaterra

[57] **CLAIM**

The ornamental design for a vehicle trailer body, as shown and described.

DESCRIPTION

FIG. 1 is a rear and left side perspective view of our vehicle trailer body;
FIG. 2 is a top view thereof;
FIG. 3 is a left side view thereof;
FIG. 4 is a front view thereof;
FIG. 5 is a rear view thereof; and,
FIG. 6 is a right side view thereof;
It will be understood that the broken line showing of the tires and wheels throughout the drawings is for illustrative purposes only and forms no part of the claimed design.

1 Claim, 3 Drawing Sheets

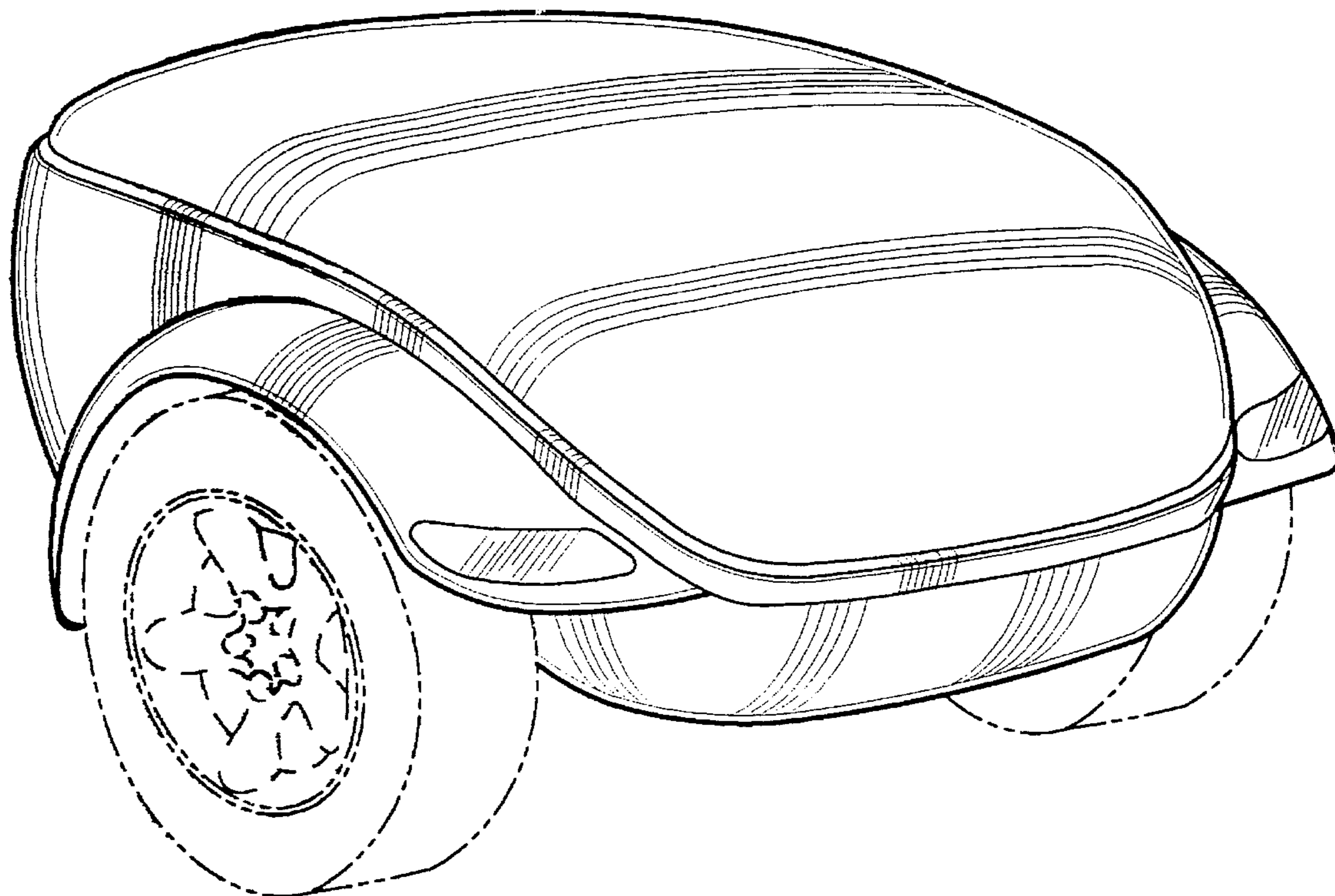

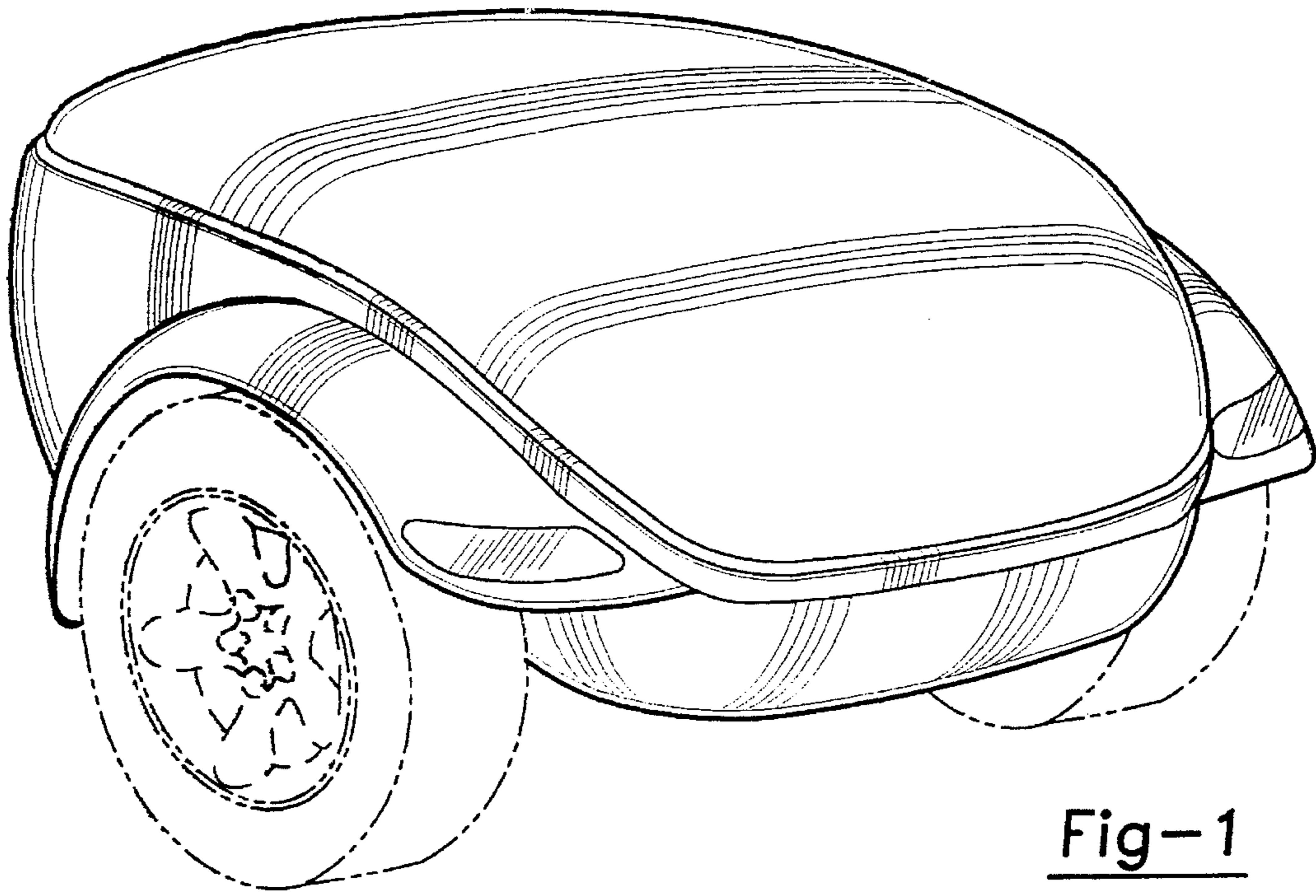

Fig-1

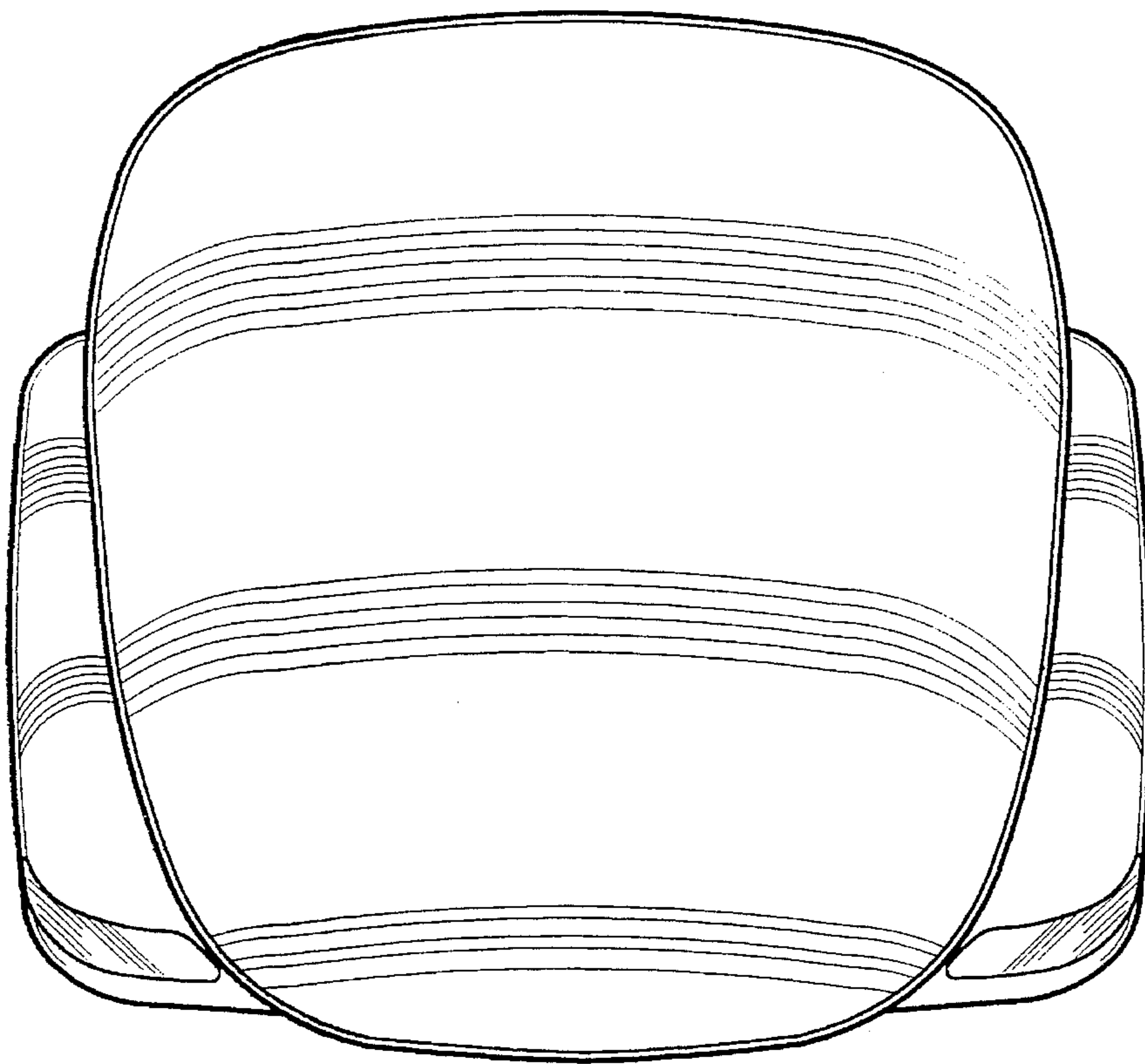

Fig-2

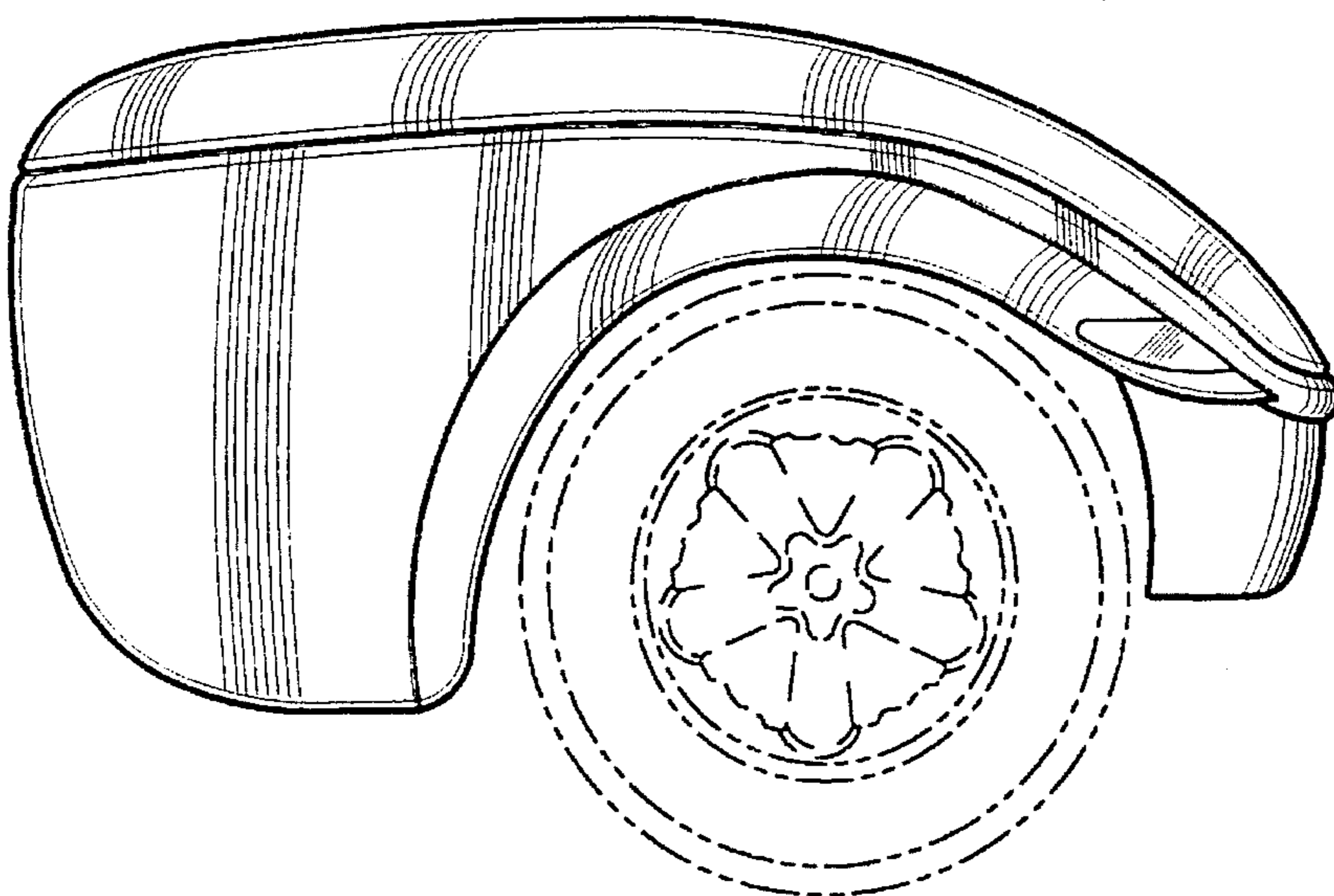

Fig-3

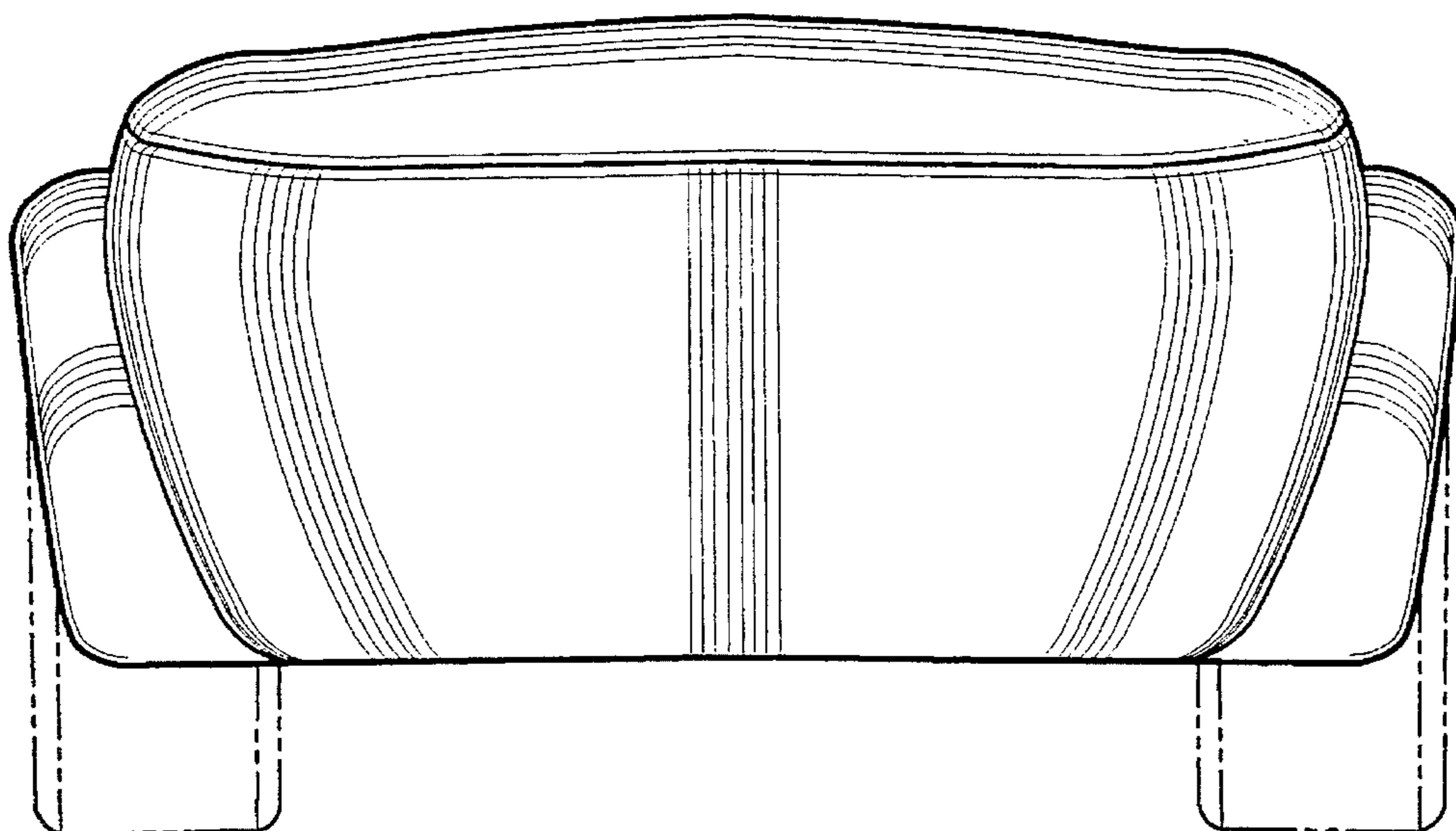

Fig-4

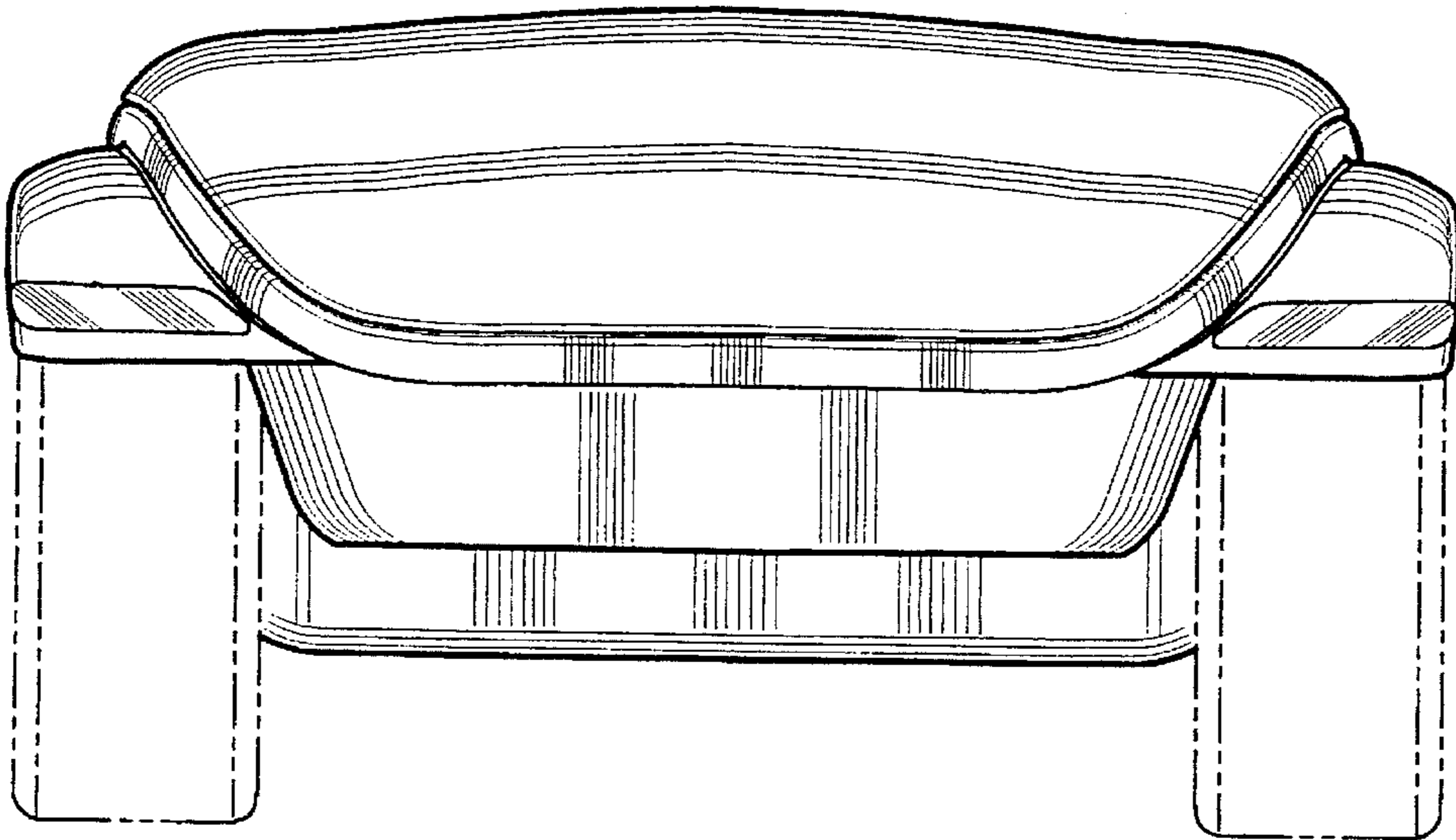

Fig-5

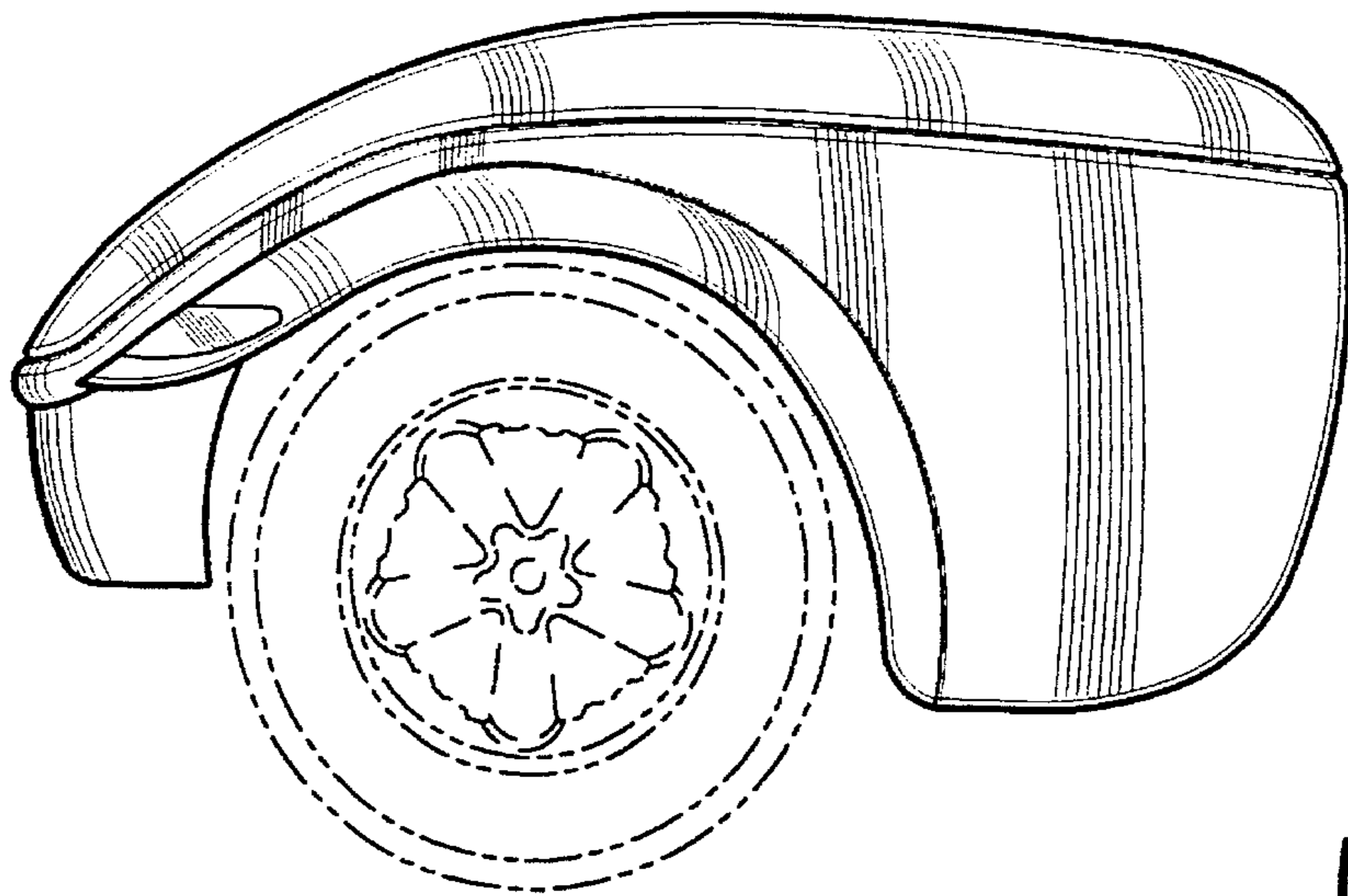

Fig-6