



US00D376773S

United States Patent [19]

Bell

[11] Patent Number: **Des. 376,773**

[45] Date of Patent: ****Dec. 24, 1996**

[54] **BICYCLE TRAILER**

[76] Inventor: **Robert Bell**, 16 Oxford Street, Guelph, Ontario, Canada, N1H 2M3

[**] Term: **14 Years**

[21] Appl. No.: **27,760**

[22] Filed: **Aug. 29, 1994**

[30] Foreign Application Priority Data

Mar. 15, 1994 [CA] Canada 1994-0493

[52] U.S. Cl. **D12/101**

[58] Field of Search D12/101, 102, D12/114; 280/204, 282, 7.14

[56] References Cited

U.S. PATENT DOCUMENTS

D. 340,429	10/1993	Smith	D12/102
D. 351,575	10/1994	Fenton et al.	D12/114
3,792,875	2/1974	Paden	280/204
4,077,646	3/1978	Watkins	280/204
4,256,321	3/1981	Trubove	280/204
4,381,117	4/1983	French et al.	280/204
4,721,320	1/1988	Creps et al.	280/204
5,020,813	6/1991	Gottschalk	280/204
5,020,814	6/1991	George et al.	280/204
5,287,744	12/1993	Berry et al.	280/204
5,344,171	9/1994	Garforth-Bles	280/204

OTHER PUBLICATIONS

American Bicyclist & Motorcyclist, May 1993, p. 56 the utility trailer.

American Bicyclist & Motorcyclist, Mar. 1993, p. 46, the cycletoire.

American Bicyclist & Motorcyclist Dec. 1991, p. 18, the Aerosporter convertible jogging stroller/bicycle trailer with quick release wheels.

Primary Examiner—Melody N. Brown
Attorney, Agent, or Firm—Dino P. Clarizio

[57] CLAIM

The ornamental design for a bicycle trailer, as shown and described.

DESCRIPTION

FIG. 1 is a perspective view of a bicycle trailer showing my new design;

FIG. 2 is a side elevational view thereof;

FIG. 3 is a top plan view thereof;

FIG. 4 is an opposite side elevational view thereof;

FIG. 5 is a front elevational view thereof;

FIG. 6 is a rear elevational view thereof;

FIG. 7 is a bottom plan view thereof;

FIG. 8 is a perspective view of a second embodiment of the bicycle trailer of FIG. 1;

FIG. 9 is a front elevational view of the embodiment of FIG. 8; and,

FIG. 10 is a rear elevational view of the embodiment of FIG. 8.

1 Claim, 8 Drawing Sheets

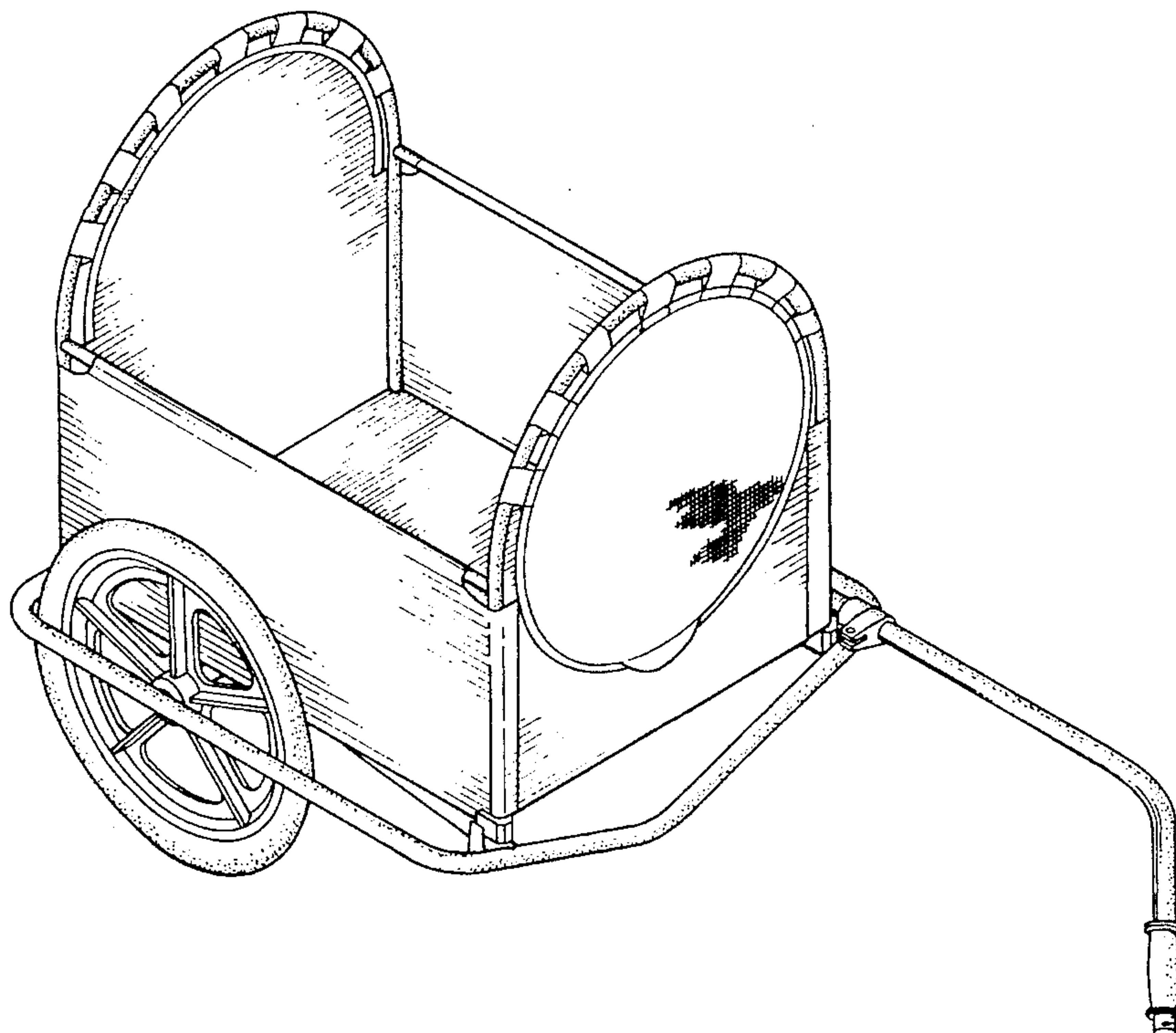

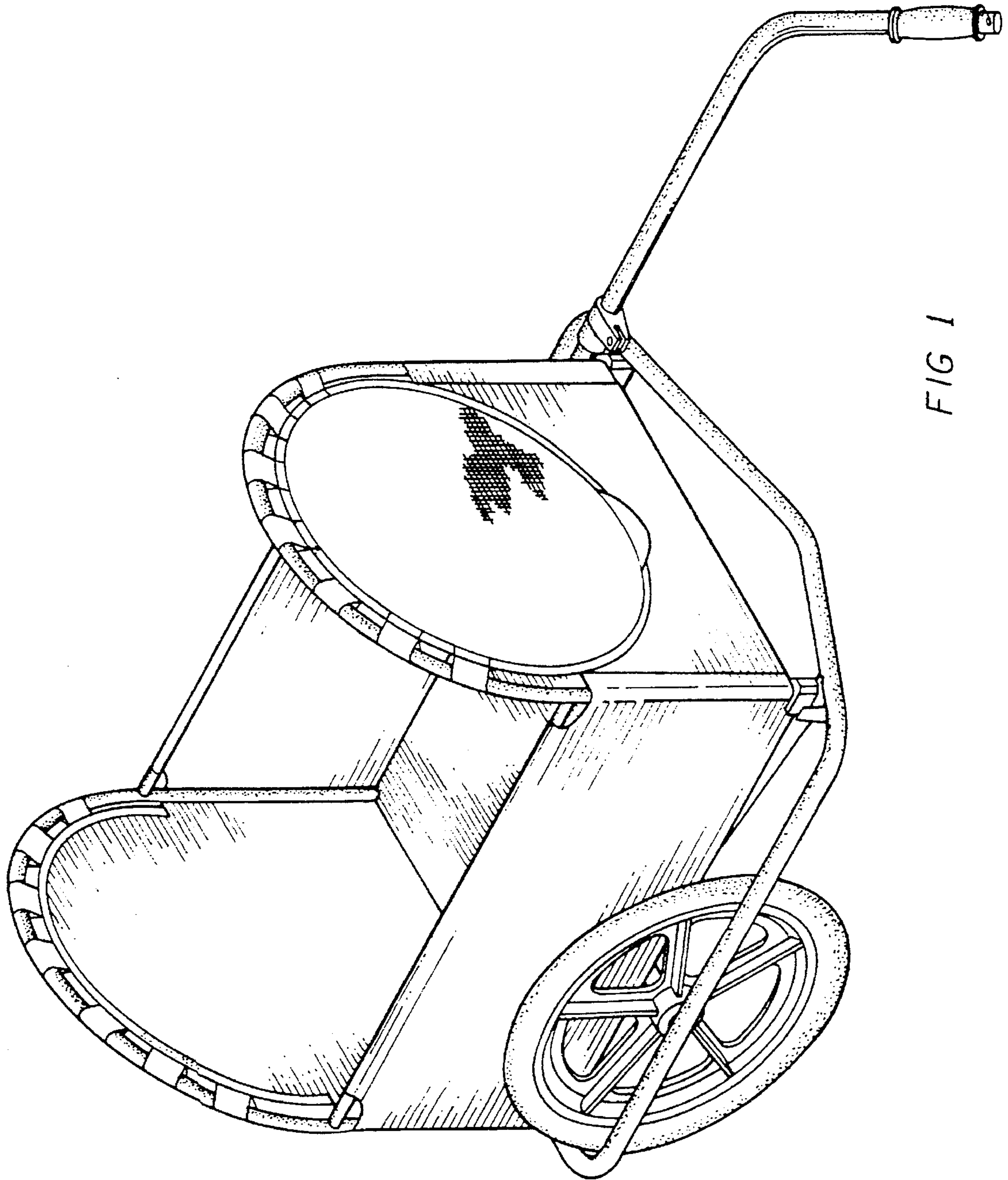

FIG 1

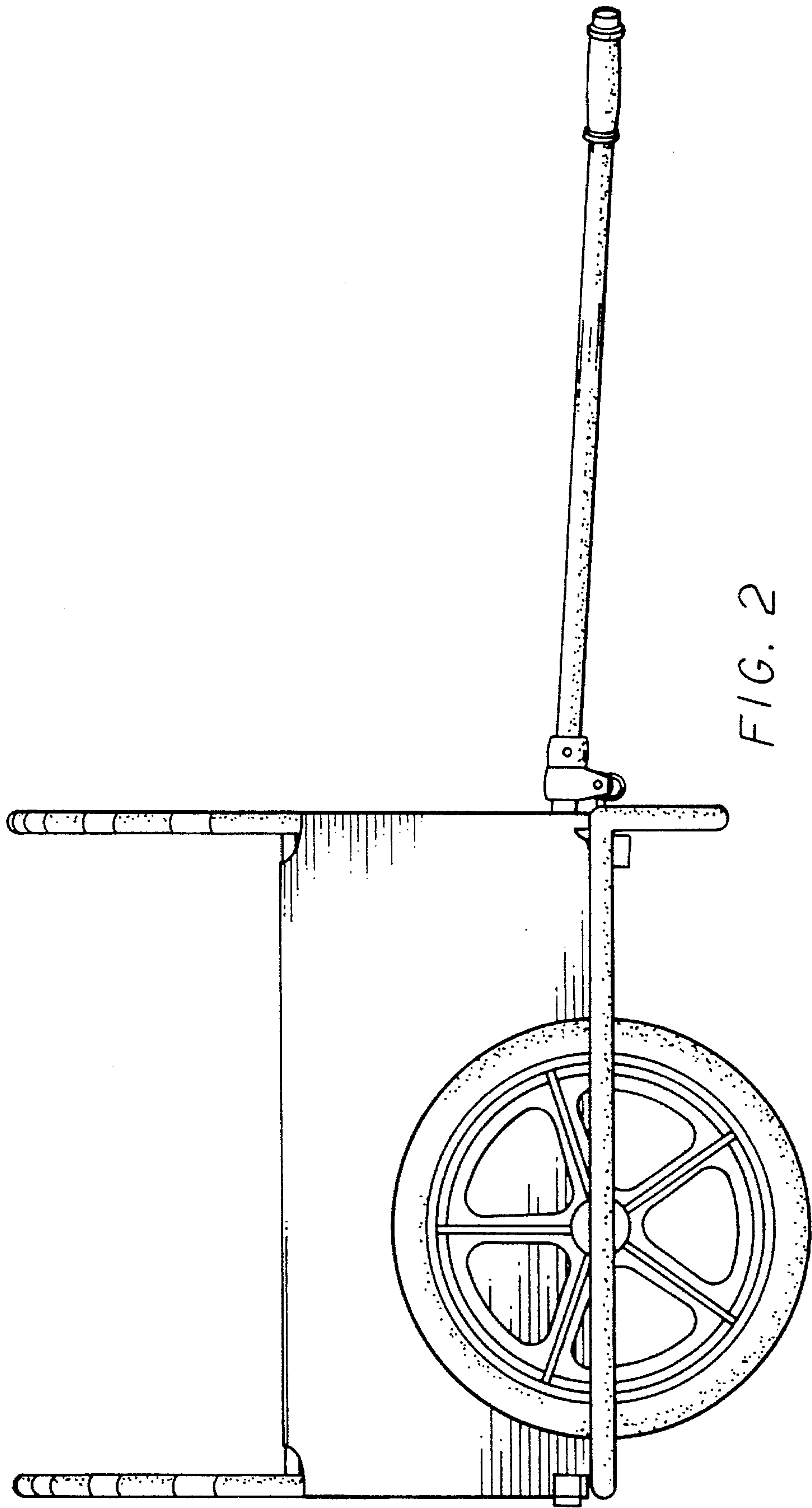

FIG. 2

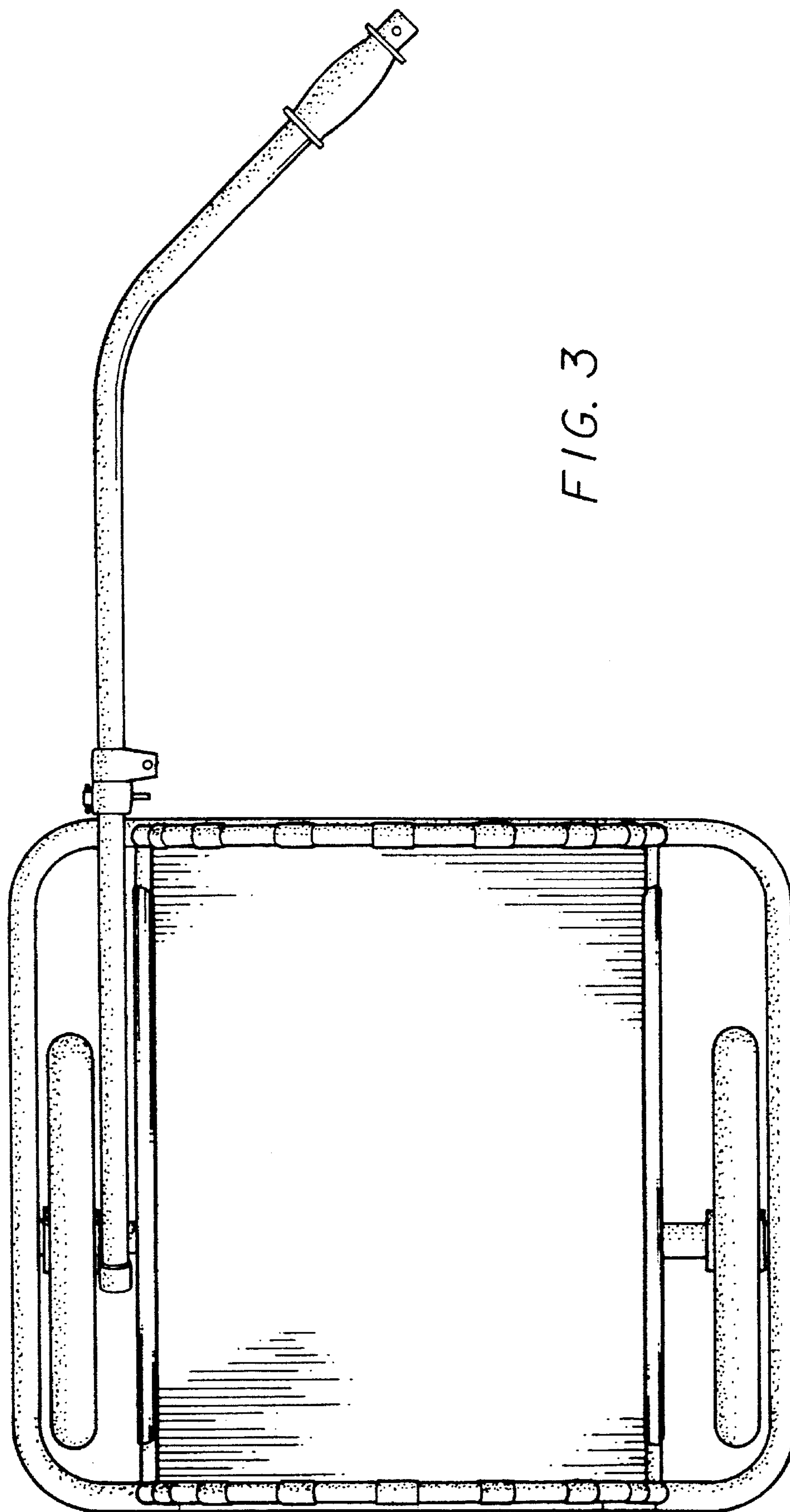

FIG. 3

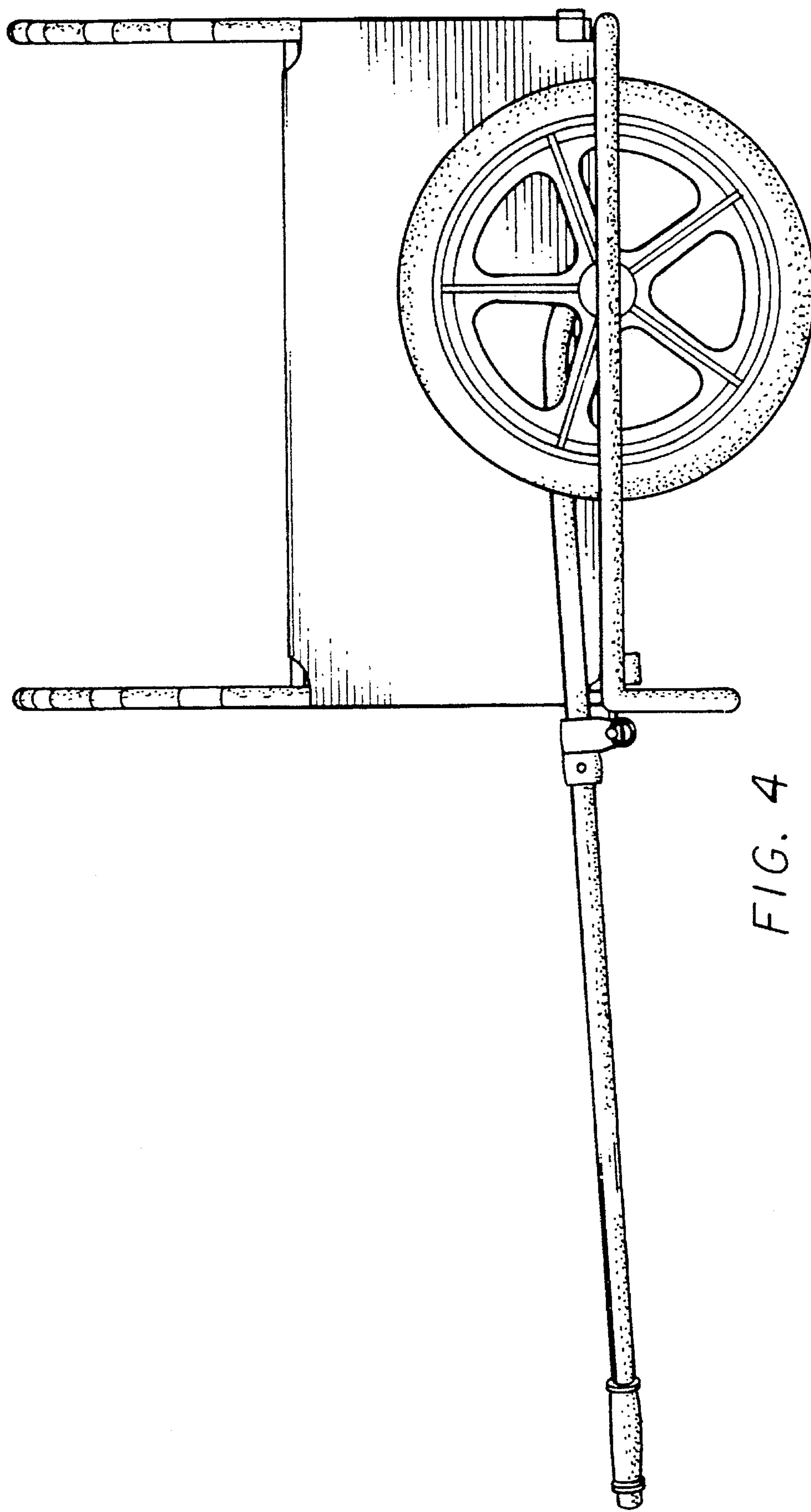

FIG. 4

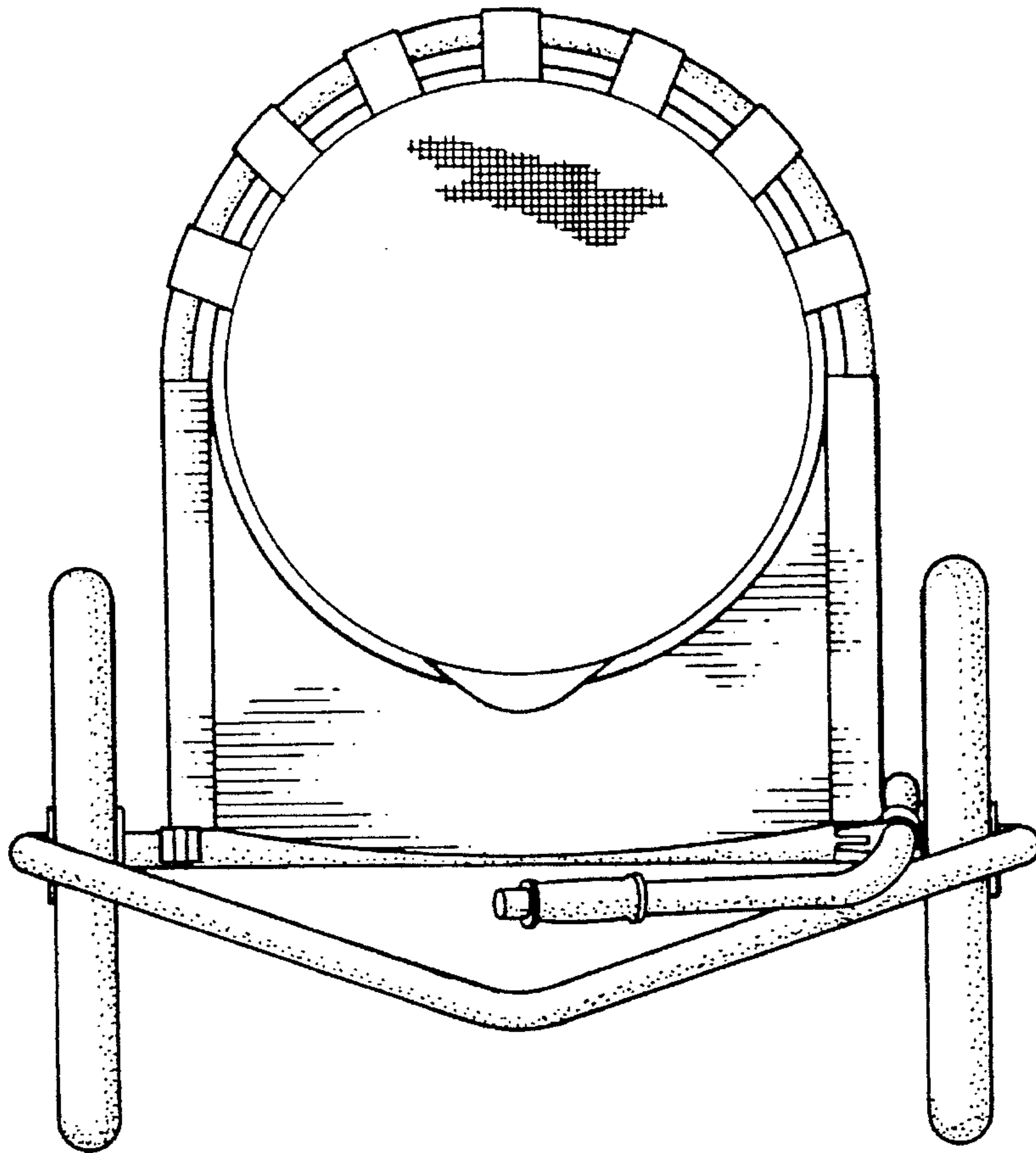

FIG. 5

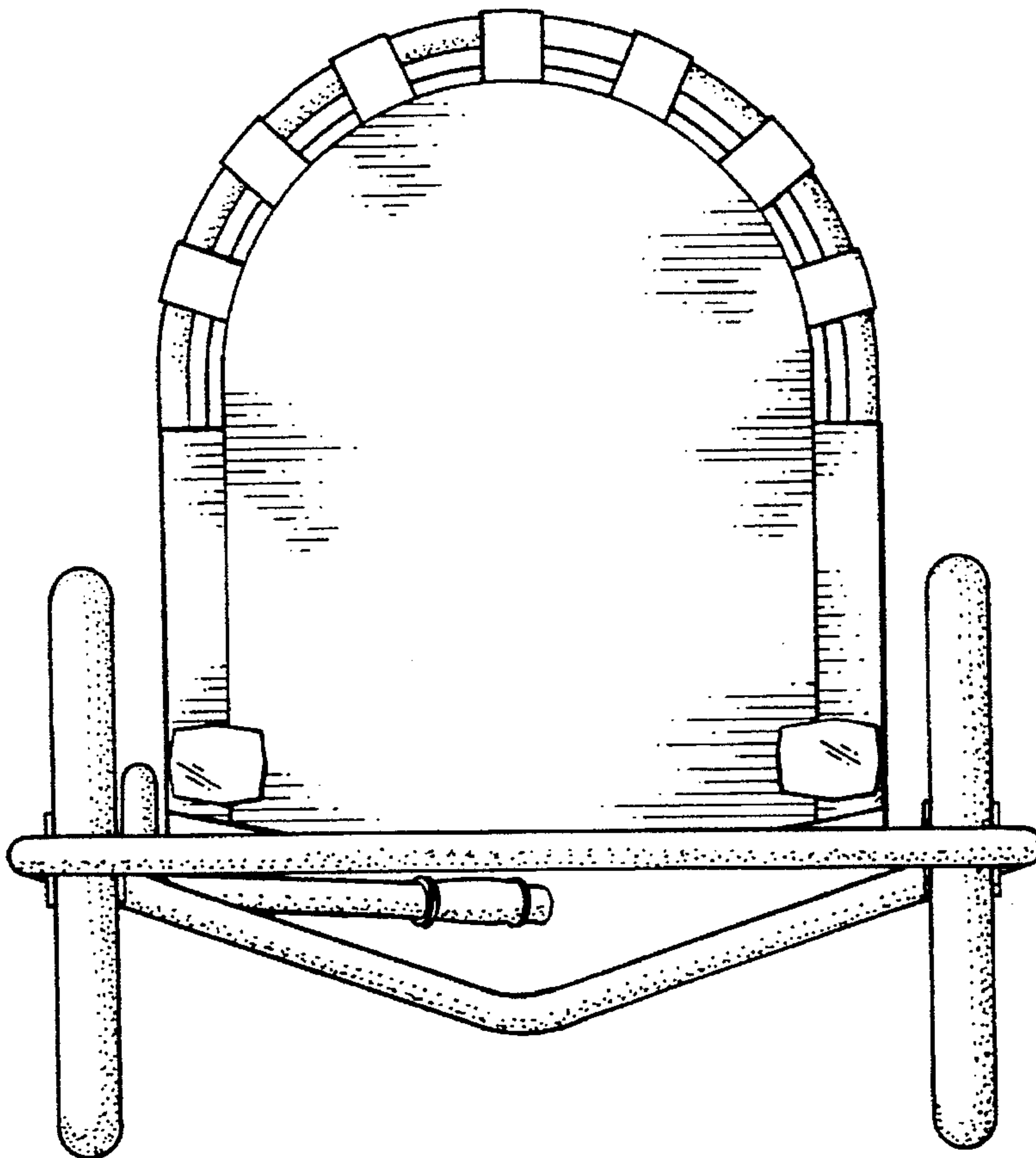
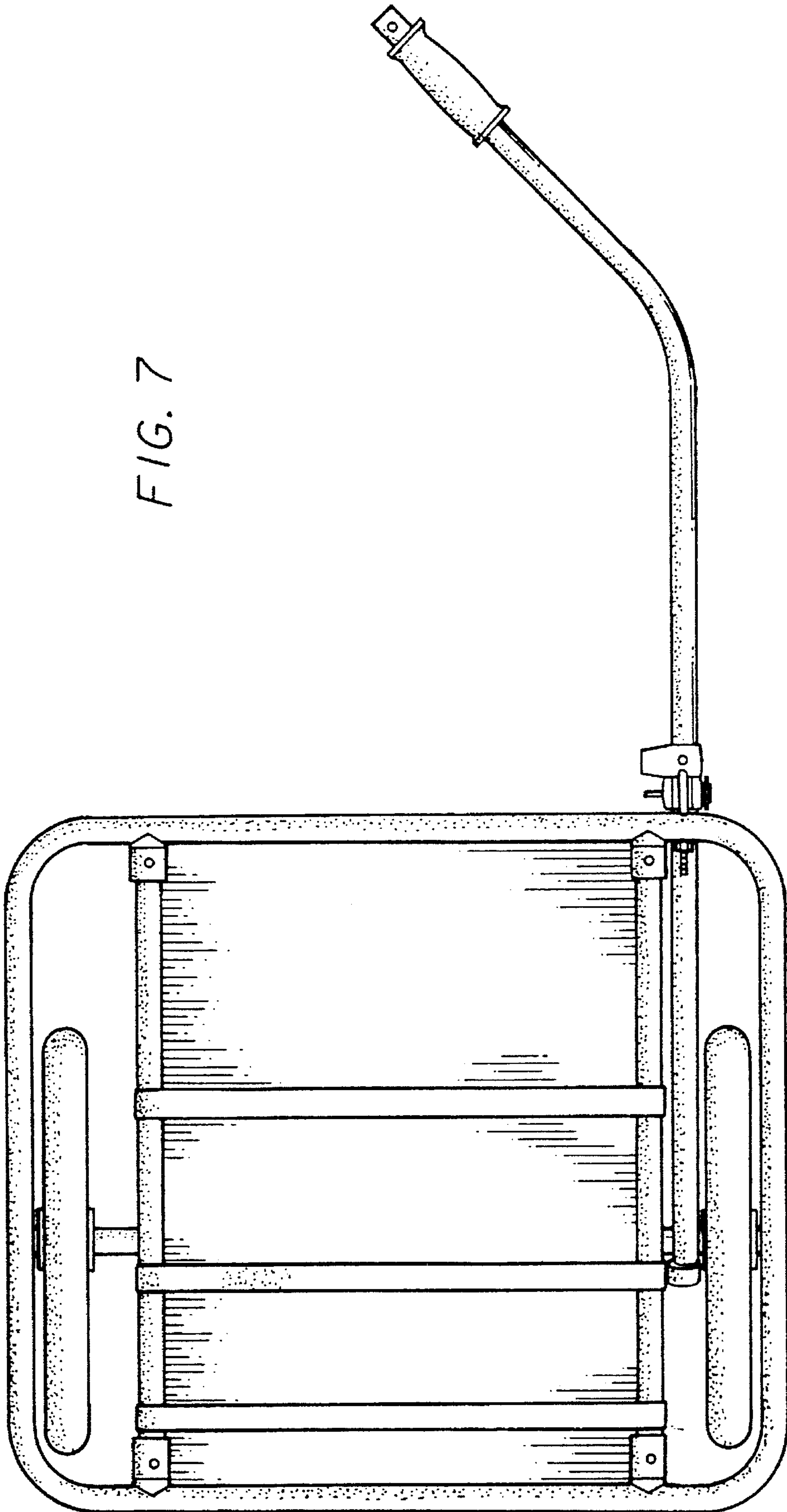

FIG. 6

FIG. 7



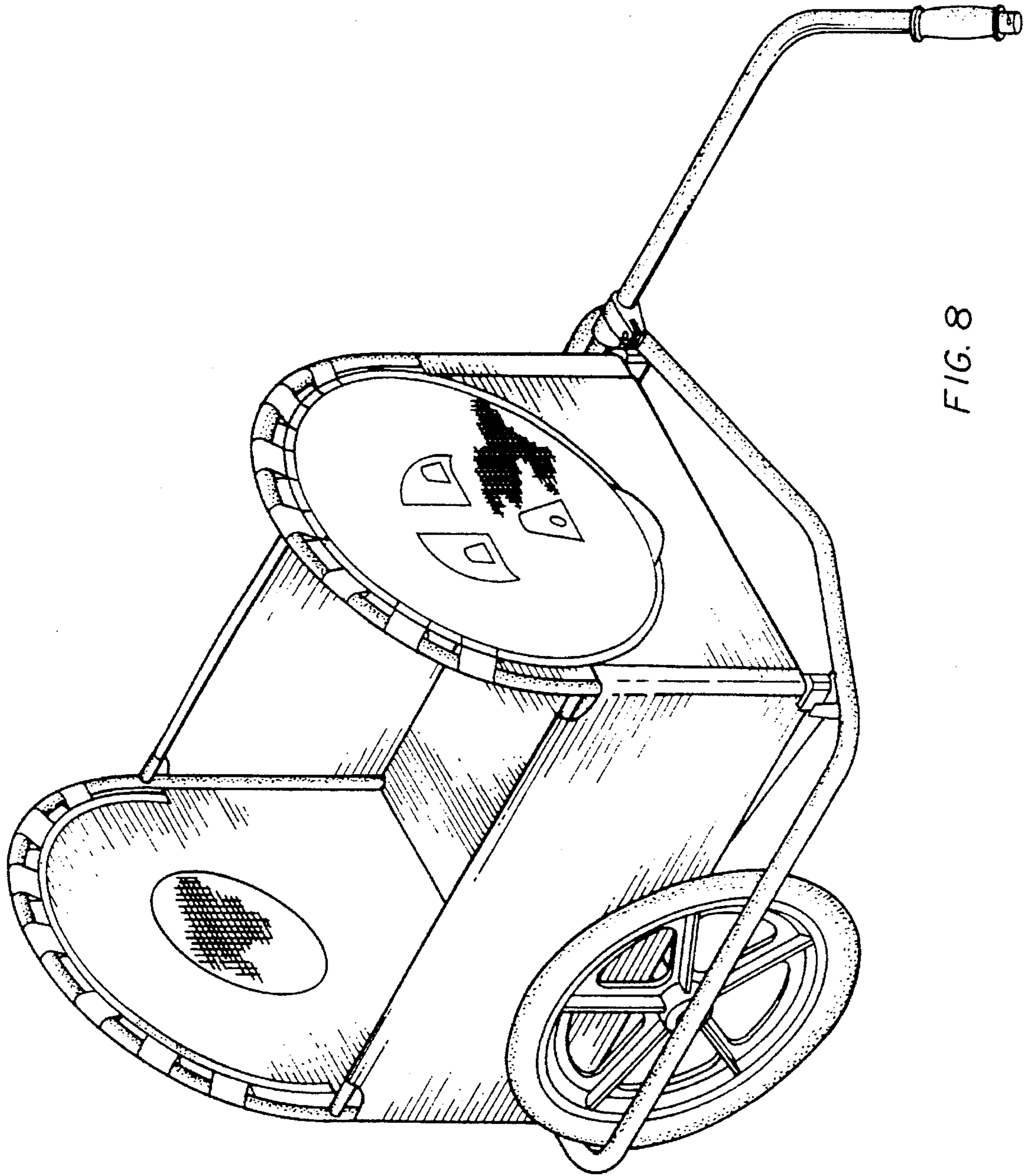

FIG. 8

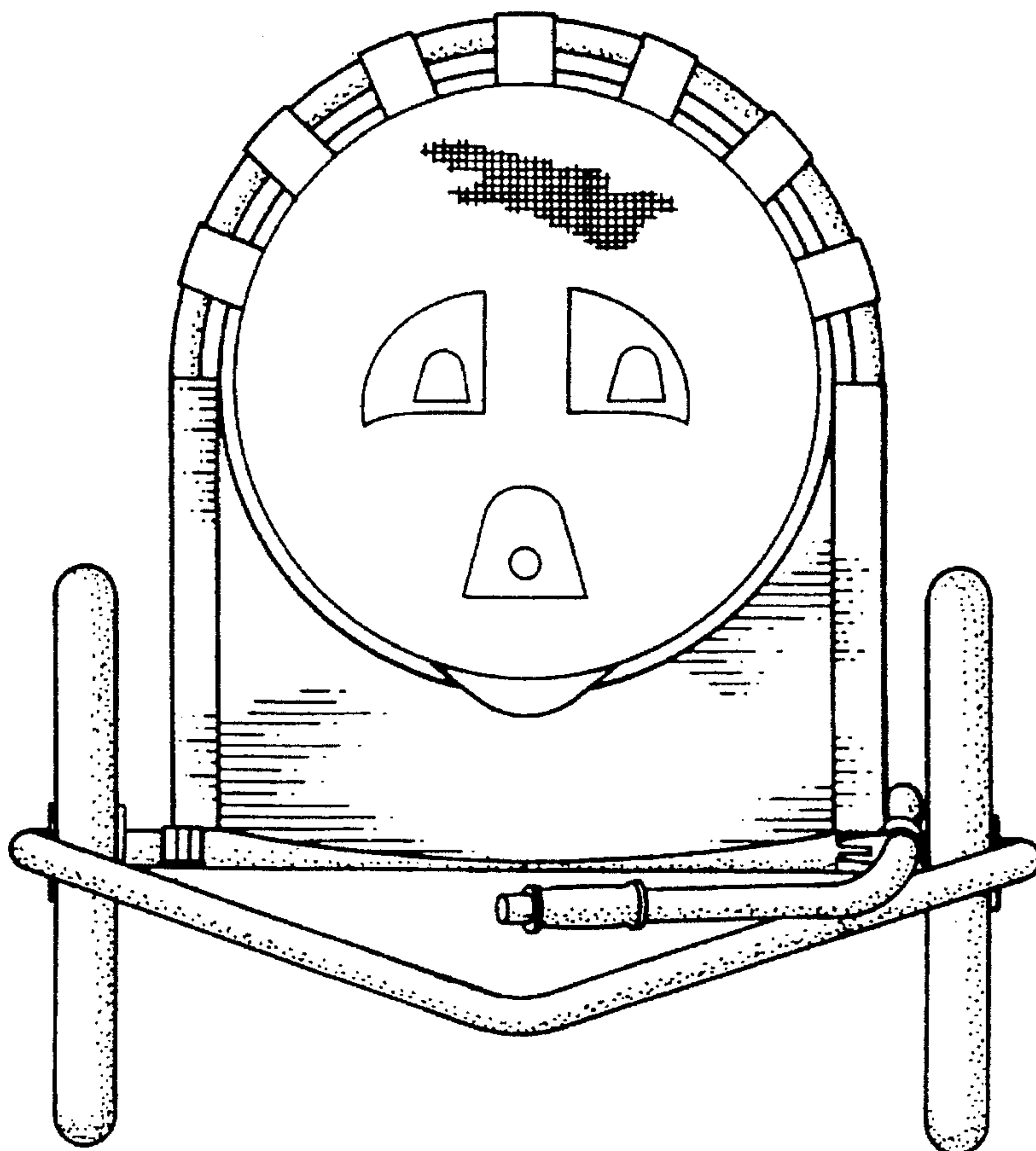

FIG. 9

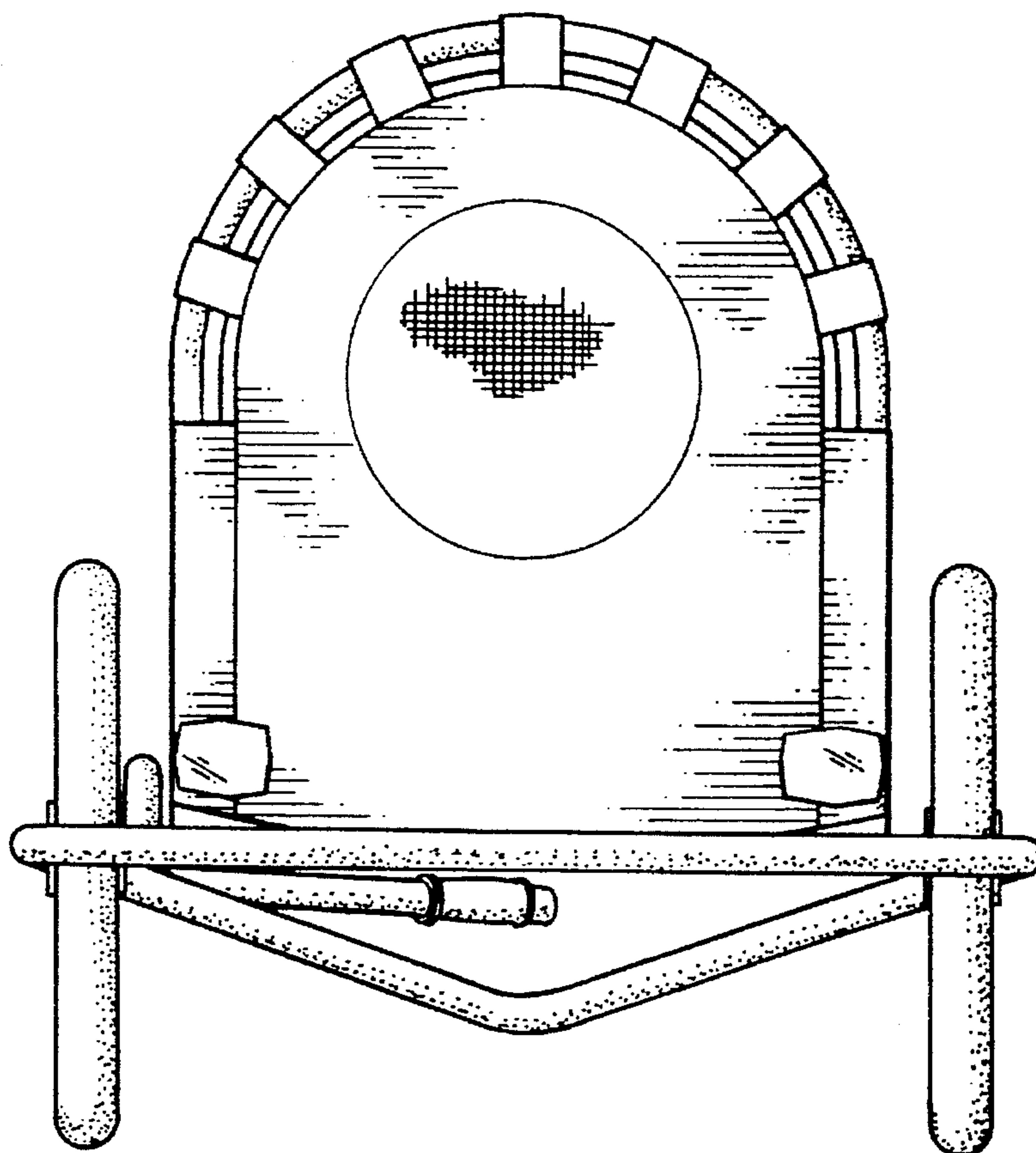

FIG. 10