



US00D376754S

United States Patent [19]

[11] **Patent Number: Des. 376,754**

Livingston et al.

[45] **Date of Patent: **Dec. 24, 1996**

[54] **REVEAL TRACK**

5,117,598 6/1992 Livingston .
5,214,892 6/1993 Livingston .

[76] Inventors: **Bryan Livingston; Douglas Hopkins; Harry O'Neil; Rob Reilly**, all of 885B S. Pickett St., Alexandria, Va. 22304

FOREIGN PATENT DOCUMENTS

2021074 11/1970 Germany .
389873 7/1965 Switzerland .
2051914A 1/1981 United Kingdom .

[**] Term: **14 Years**

Primary Examiner—Holly H. Baynham
Attorney, Agent, or Firm—Wenderoth, Lind & Ponack

[21] Appl. No.: **38,419**

[22] Filed: **May 5, 1995**

[52] U.S. Cl. **D8/377; D25/125**

[57] **CLAIM**

[58] **Field of Search** D8/376-377; D25/119-121, D25/125; 16/87 R, 87.4 R, 94 R, 96 R; 160/201-203

The ornamental design for a reveal track, as shown and described.

DESCRIPTION

[56] **References Cited**

U.S. PATENT DOCUMENTS

D. 177,034	3/1956	Fridolph	D8/377
D. 268,809	5/1983	Marontate	D8/377
D. 335,624	5/1993	Siener	D8/377
D. 345,498	3/1994	Fraser et al.	D8/376 X
3,303,626	2/1967	Brigham .	
3,513,613	5/1970	Jones et al. .	
3,857,216	12/1974	Sherman .	
4,018,260	4/1977	Baslow .	
4,053,008	10/1977	Baslow .	
4,151,762	5/1979	Baslow .	
4,161,977	7/1979	Baslow .	
4,189,880	2/1980	Balin .	
4,197,686	4/1980	Baslow .	
4,333,284	6/1982	Meadows .	
4,441,290	4/1984	Abell .	
4,590,727	5/1986	Ghahremani et al. .	
4,625,490	12/1986	Baslow .	
4,631,882	12/1986	Sease .	
4,731,960	3/1988	Sease .	
4,788,806	12/1988	Sease .	

FIG. 1 is a fragmented top, right hand and front perspective view of a first embodiment of a design for a reveal track; FIG. 2 is a cross sectional view taken along line 2—2 of FIG. 1; FIG. 3 is a top view of the reveal track of FIG. 1; FIG. 4 is a bottom view of the reveal track of FIG. 1; FIG. 5 is a front view of the reveal track of FIG. 1; FIG. 6 is a cross sectional view taken along line 6—6 of FIG. 1; FIG. 7 is a left hand side view of the reveal track of FIG. 1; FIG. 8 is a right hand side view of the reveal track of FIG. 1; FIG. 9 is a fragmented perspective view of a reveal track according to a second embodiment of the present invention; FIG. 10 is a cross sectional view taken along line 10—10 of FIG. 11; and, FIG. 11 is a front view of the reveal track of FIG. 9 with the rear view being identical in appearance.

1 Claim, 6 Drawing Sheets

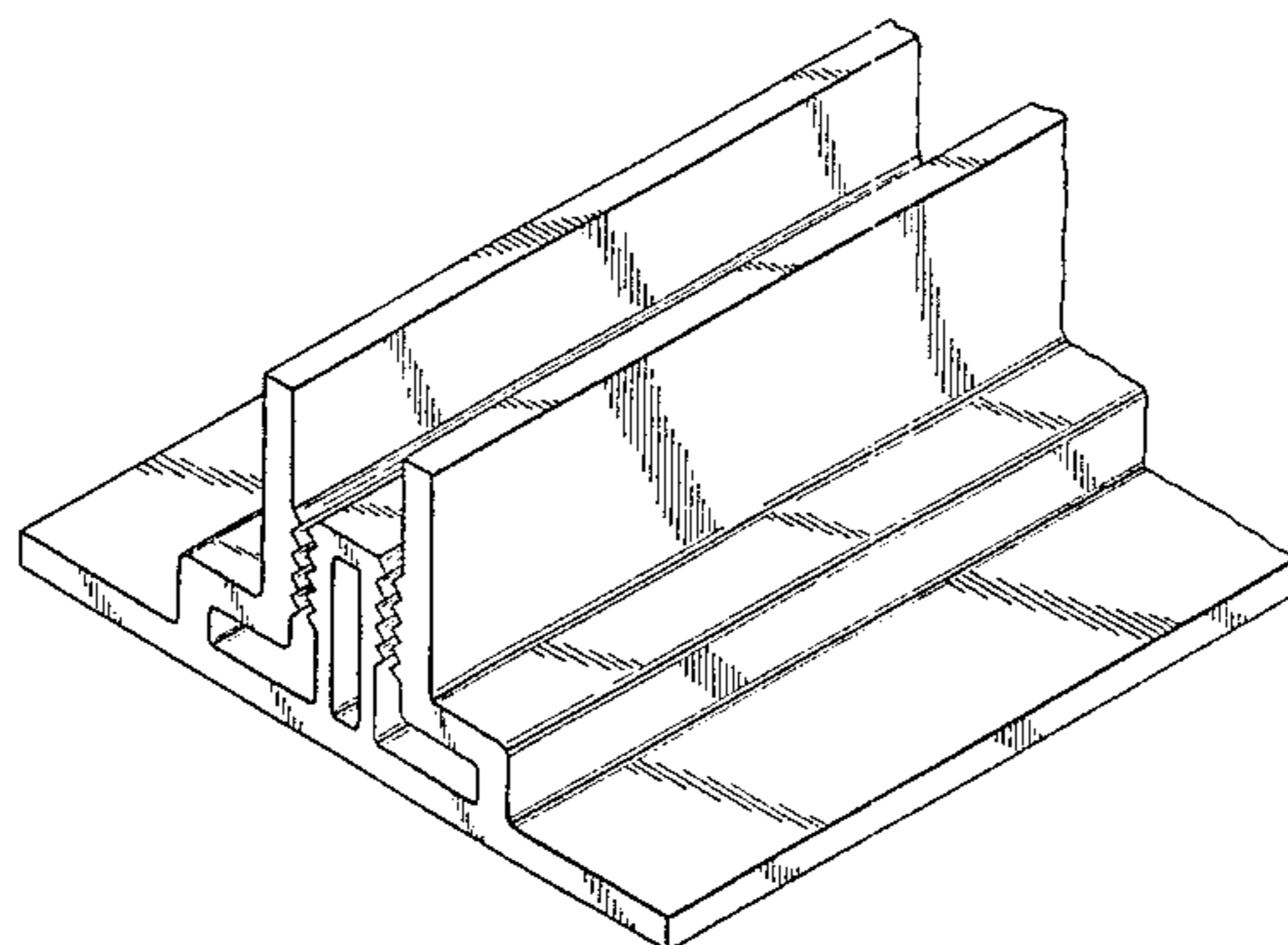
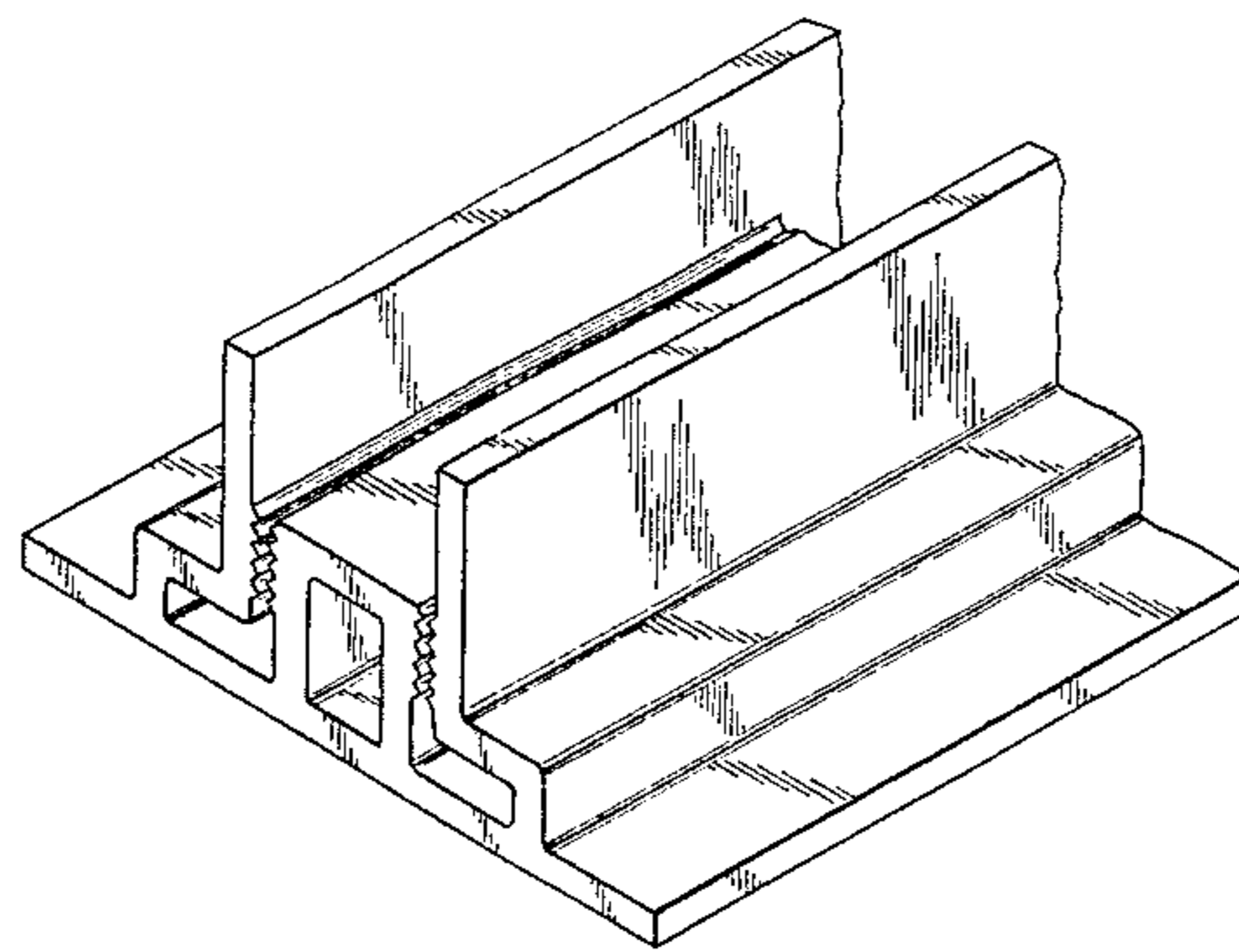

FIG. 1

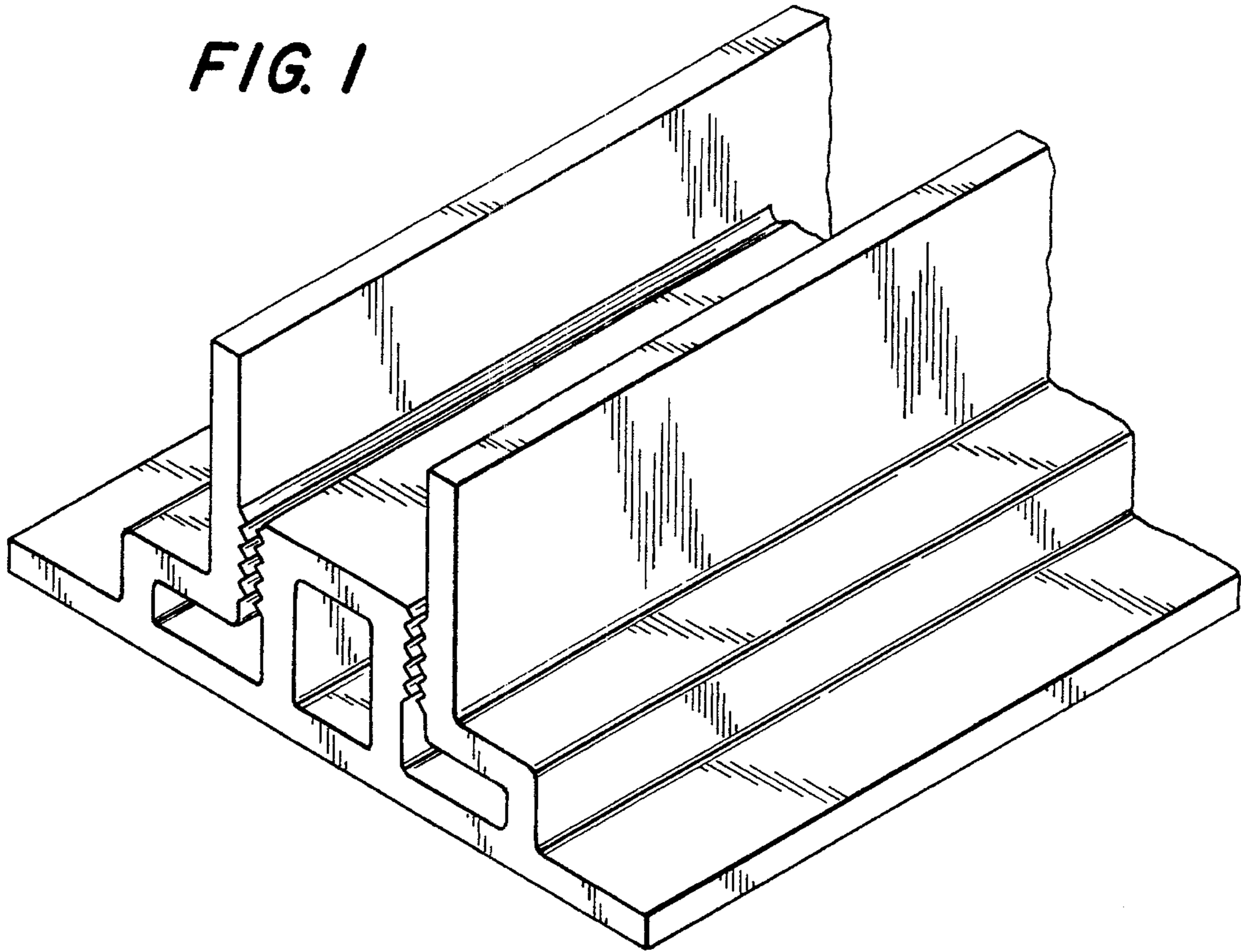

FIG. 2

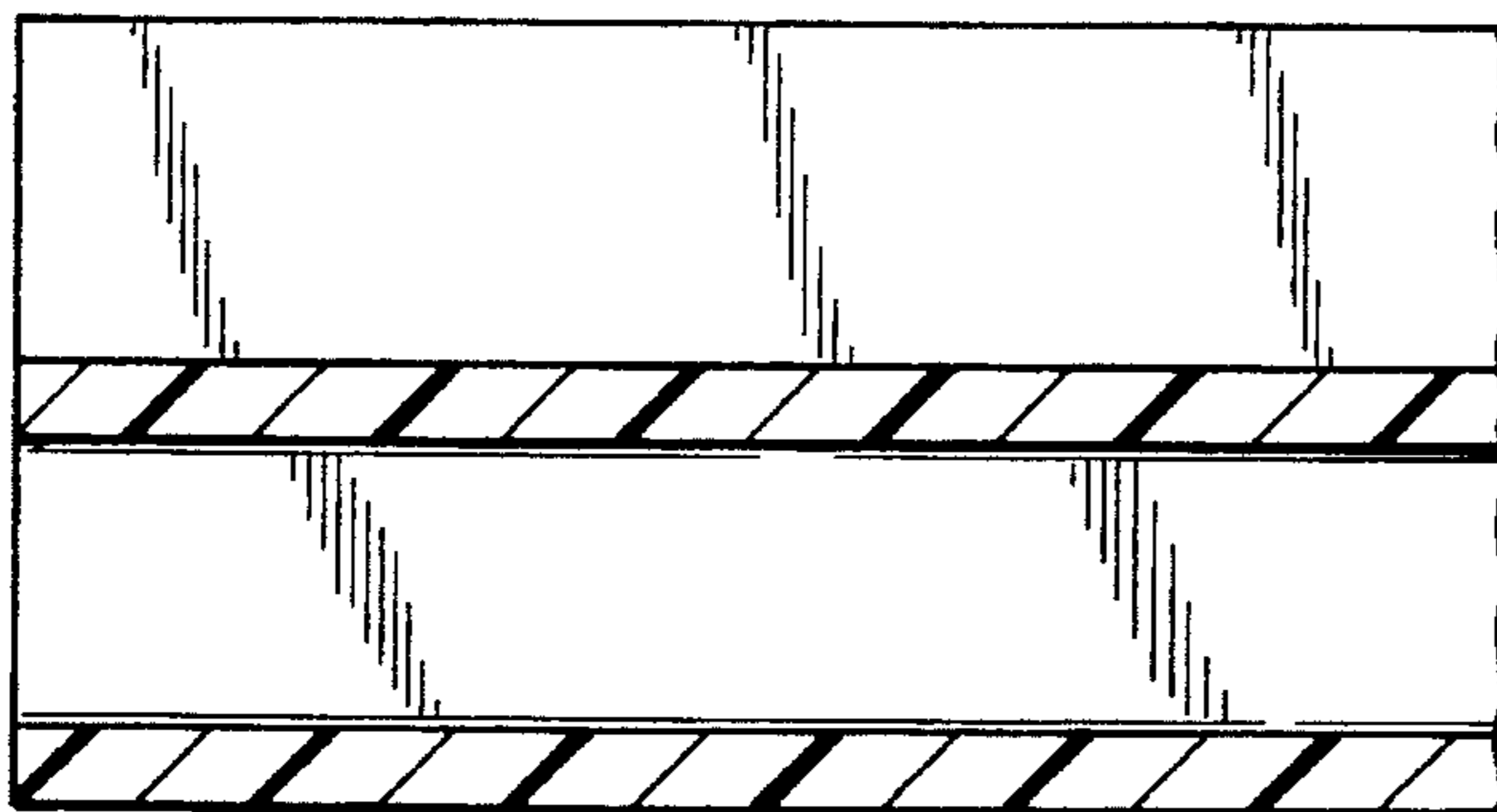

FIG. 3

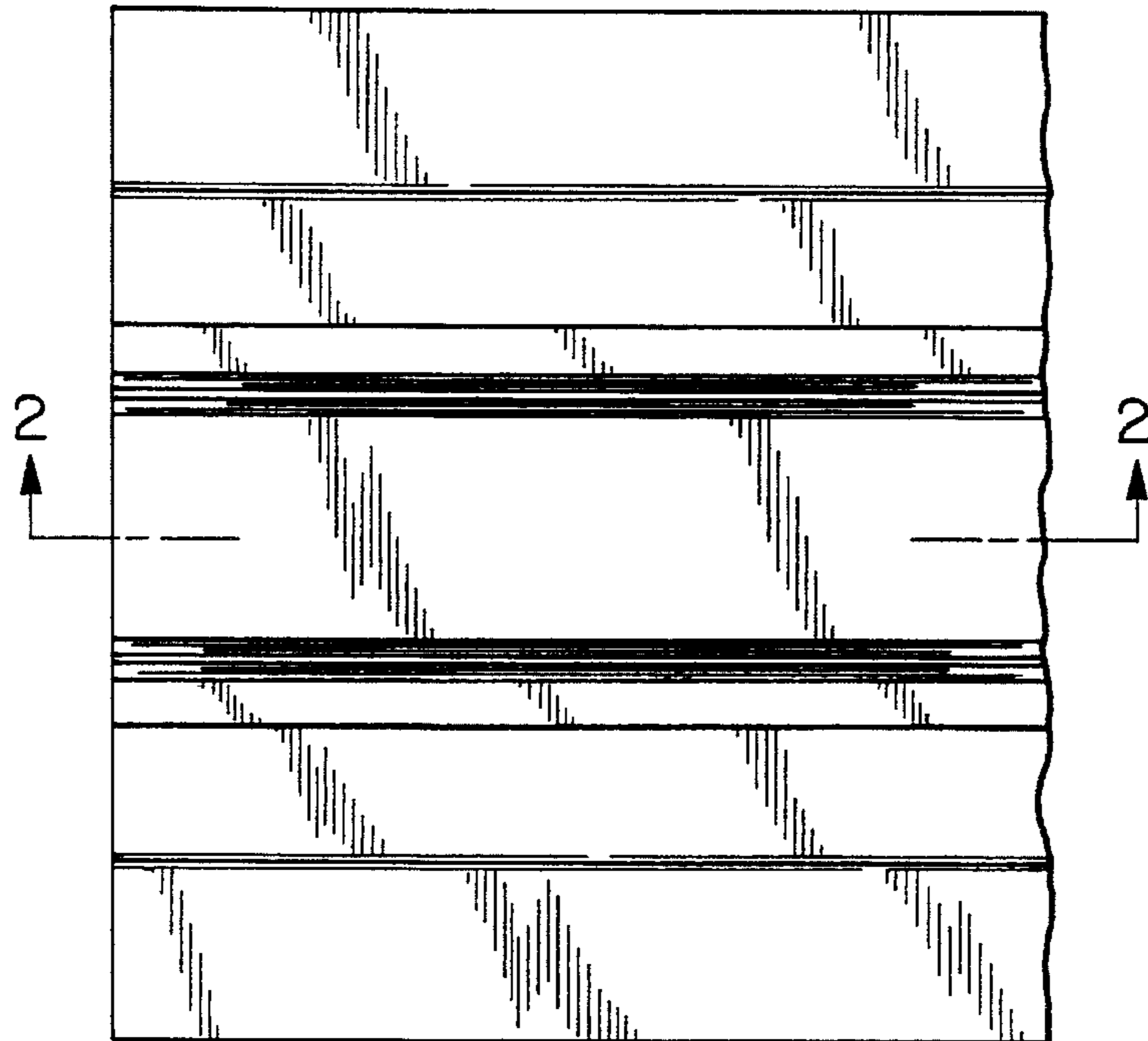

FIG. 4

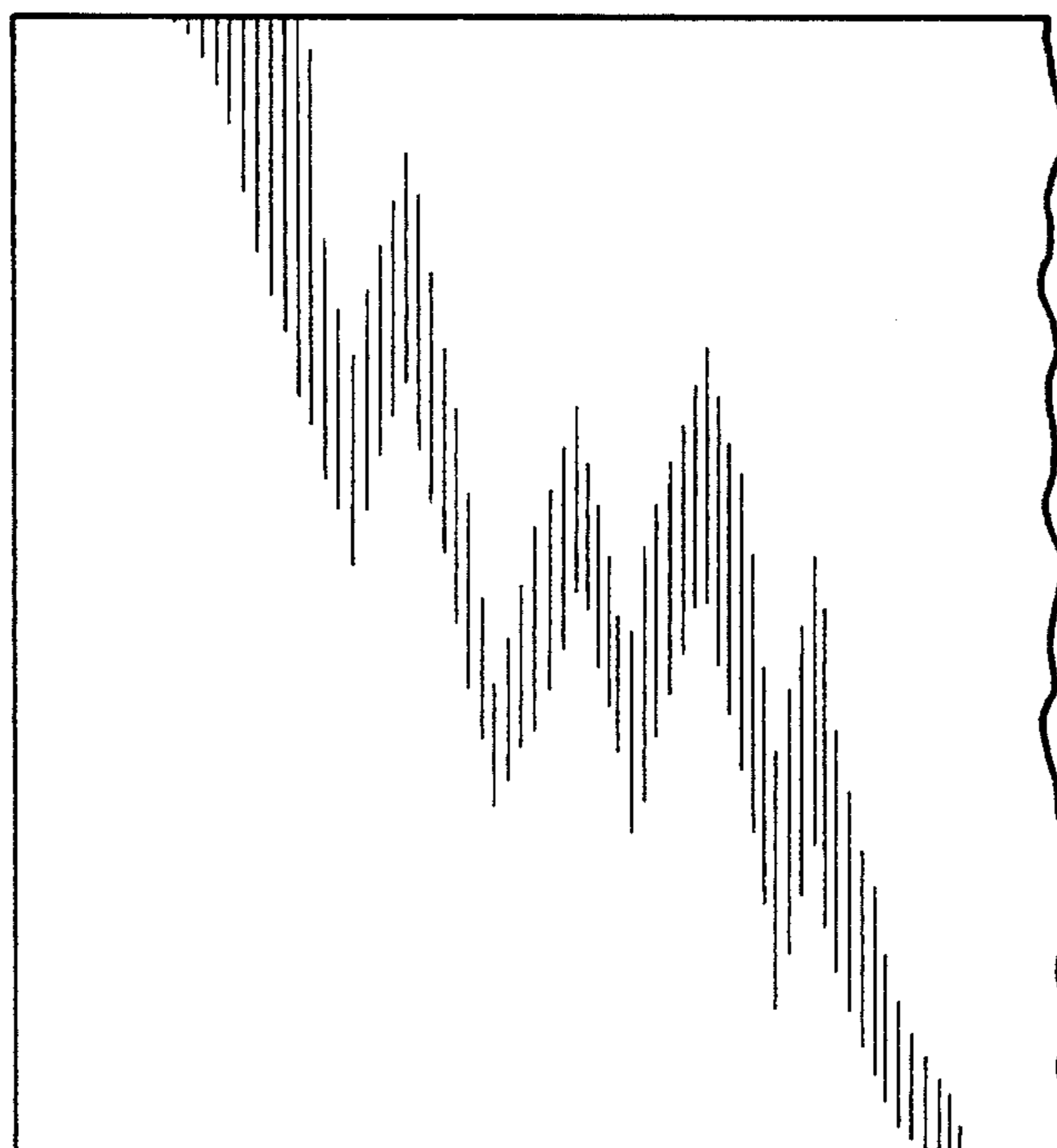

FIG. 5

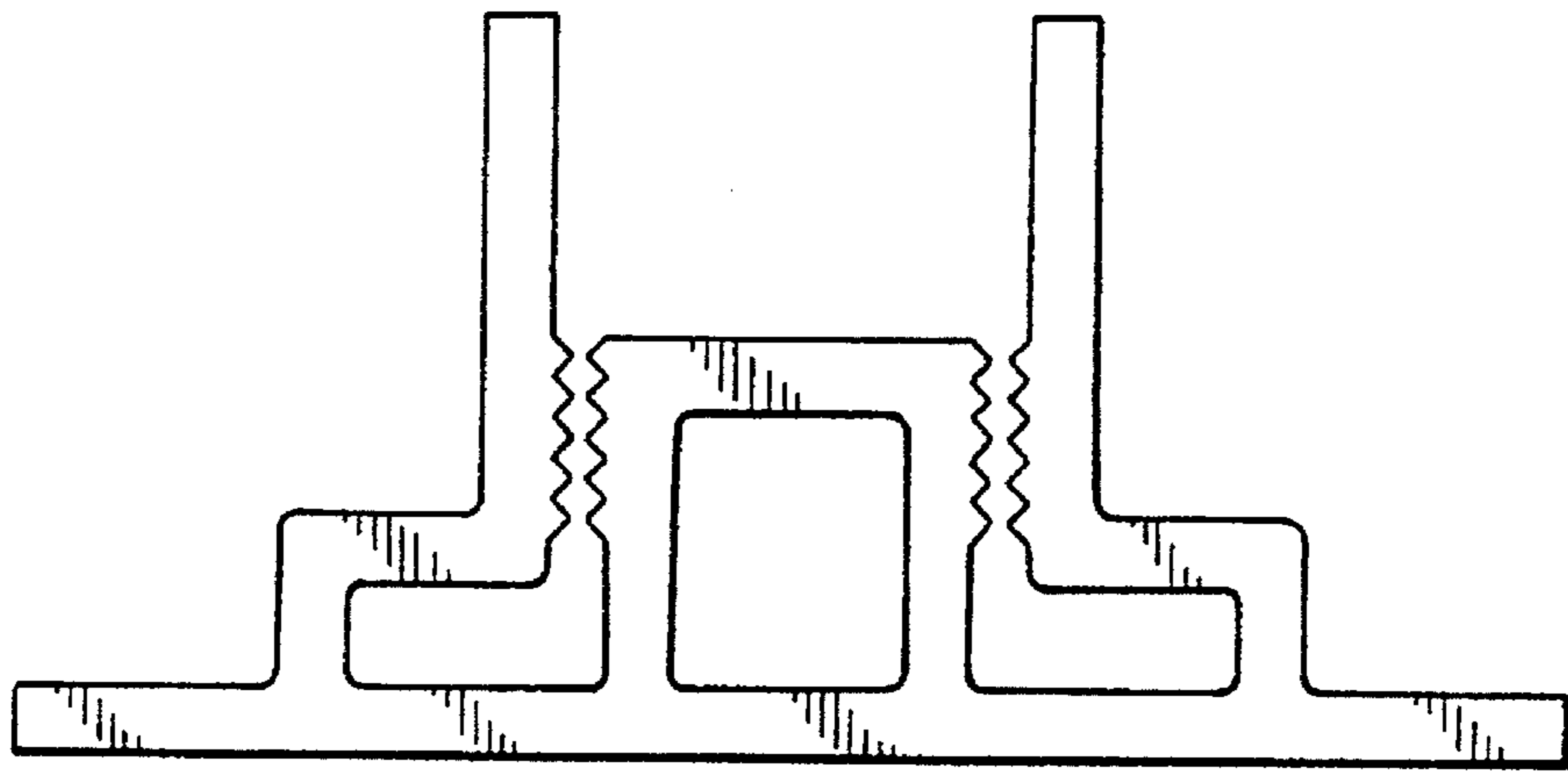

FIG. 6

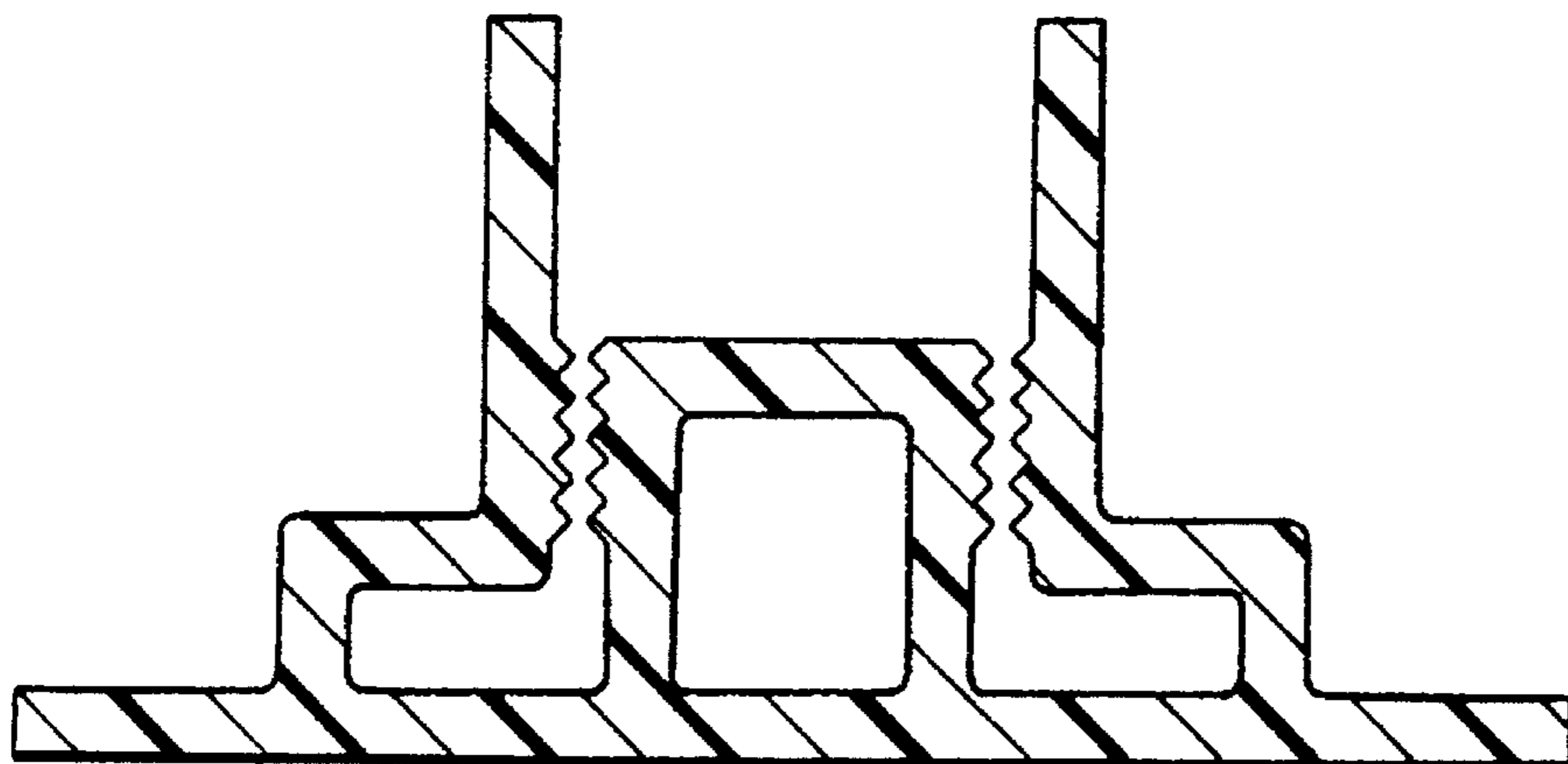

FIG. 7

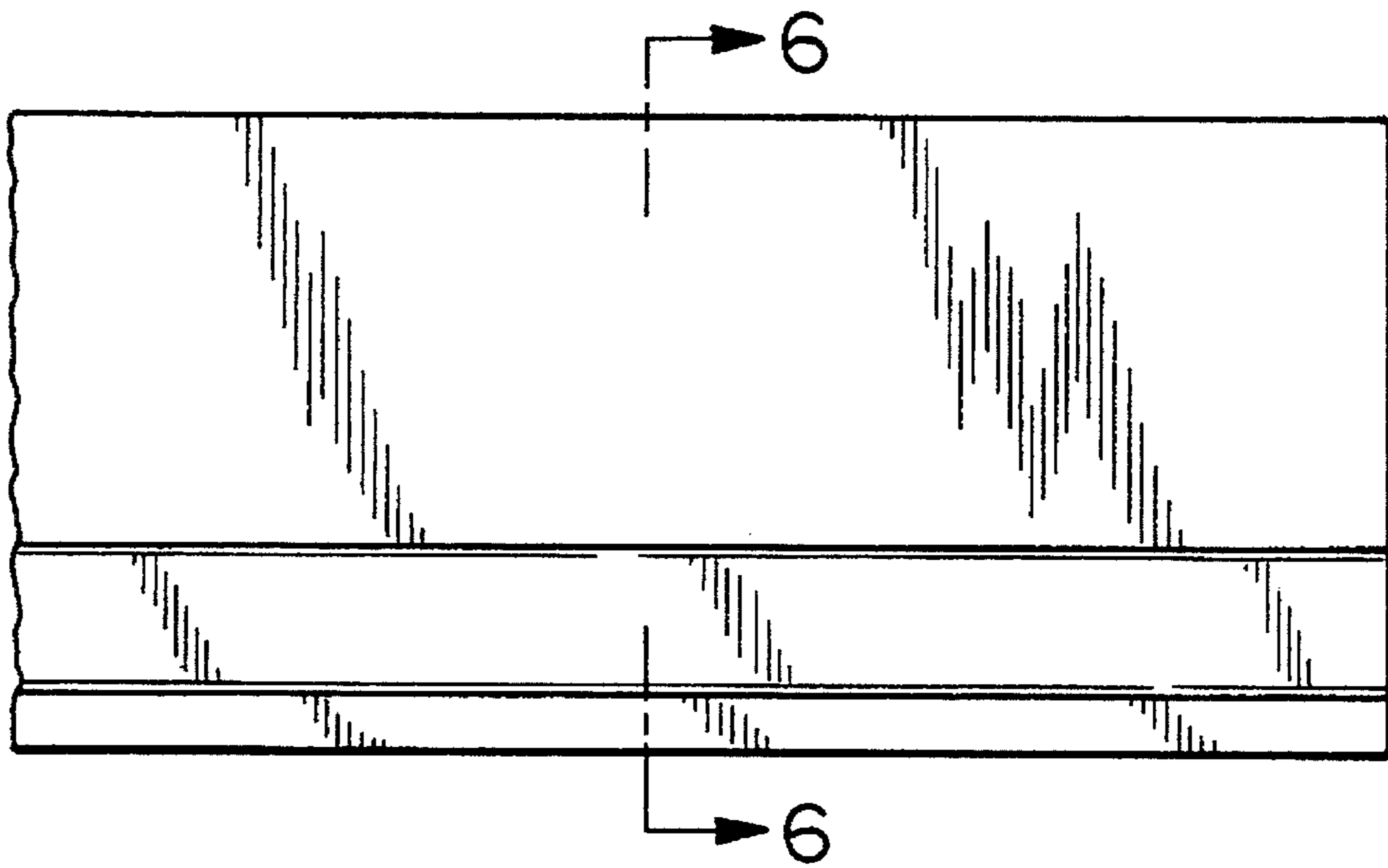

FIG. 8

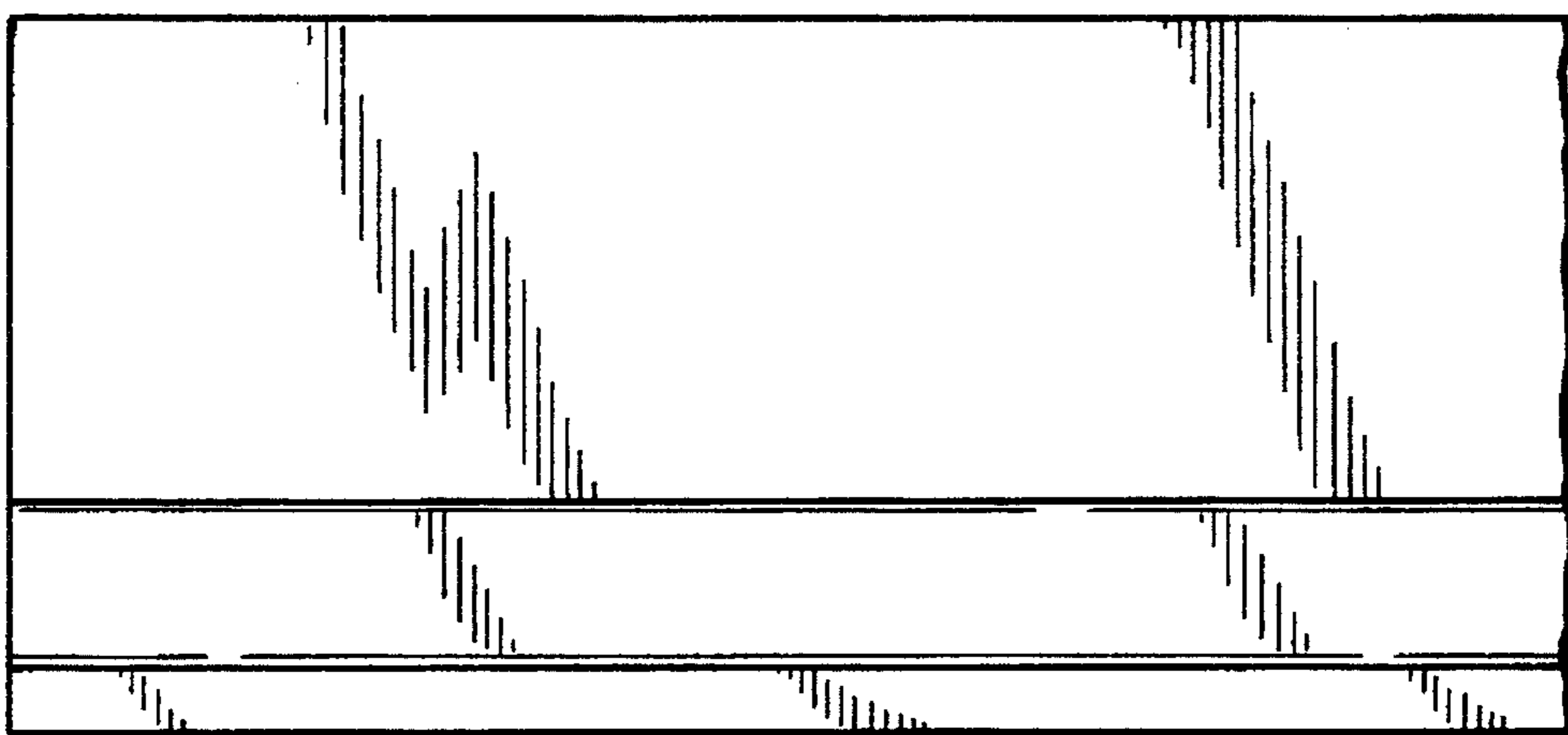

FIG. 9

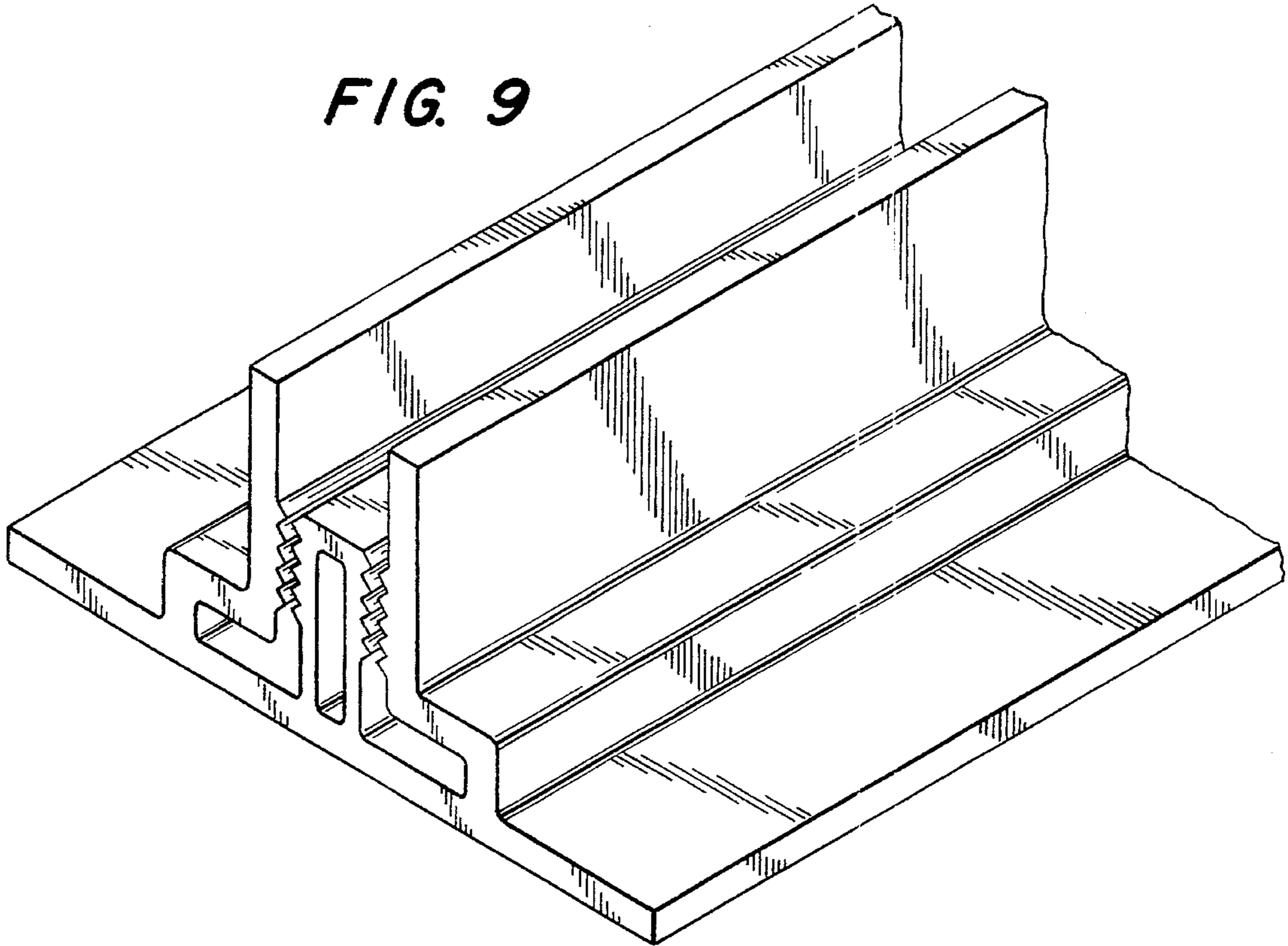

FIG. 10

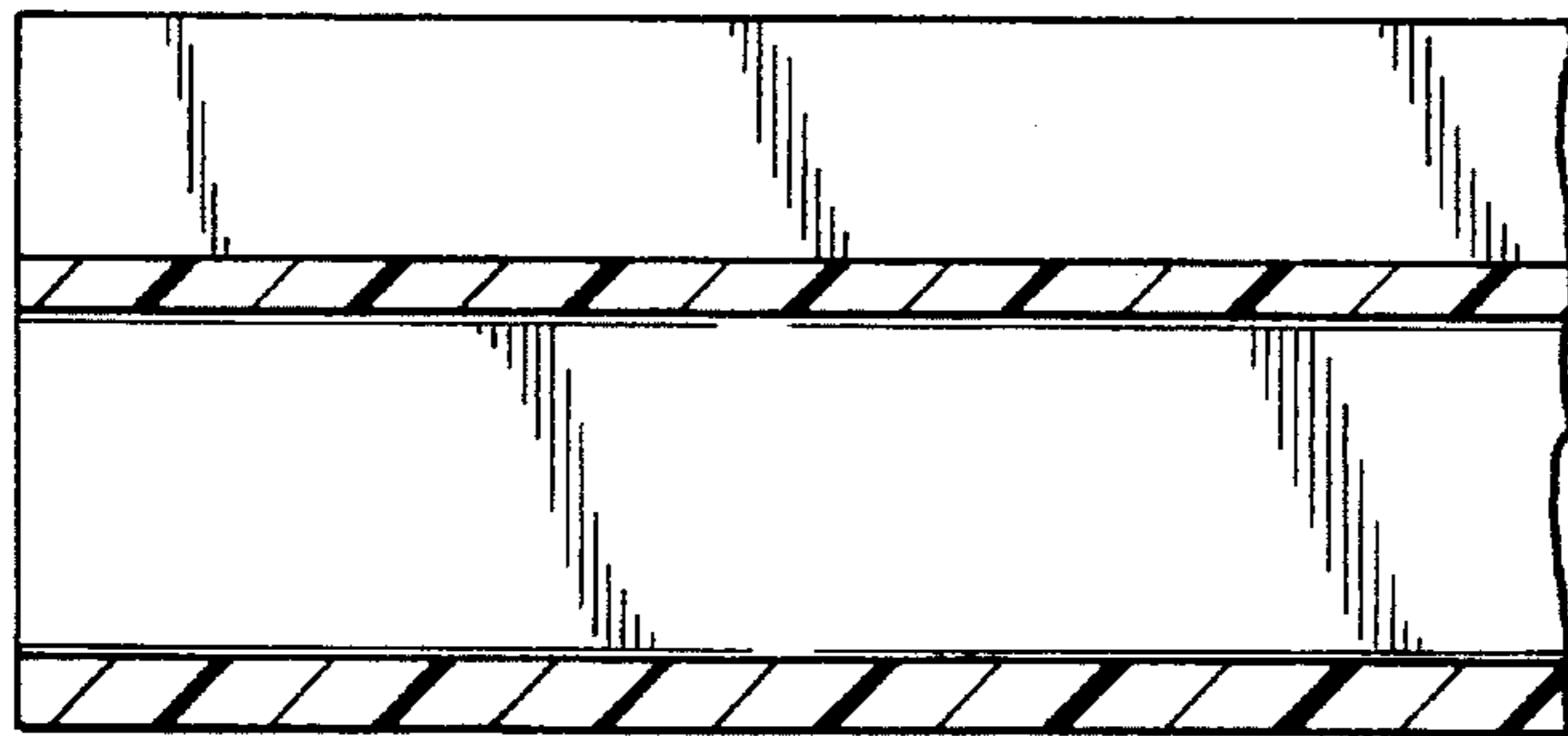

FIG. 11

