



US00D376634S

# United States Patent [19]

[11] **Patent Number: Des. 376,634**

**Toner et al.**

[45] **Date of Patent: \*\*Dec. 17, 1996**

[54] **AIRFLOW FRICTION REDUCER FOR WATERCRAFTS**

4,854,904 8/1989 Wahl ..... 114/133 X  
5,133,681 7/1992 Lobe ..... 114/127 X

[76] Inventors: **James S. Toner; Paul A. Toner**, both of Lot 4668 Lights Road, Denmark, Western Australia 6333, Australia

### FOREIGN PATENT DOCUMENTS

578316 4/1986 Australia .

[\*\*] Term: **14 Years**

*Primary Examiner*—Holly H. Baynham  
*Attorney, Agent, or Firm*—Larson and Taylor

[21] Appl. No.: **12,449**

### [57] CLAIM

[22] Filed: **Sep. 2, 1993**

The ornamental design for an airflow friction reducer for watercrafts, as shown and described.

### [30] Foreign Application Priority Data

### DESCRIPTION

Mar. 2, 1993 [AU] Australia ..... 556/93

[52] **U.S. Cl.** ..... **D21/231**

[58] **Field of Search** ..... D21/231; 441/77, 441/79; 114/127, 132-133, 140, 150, 162, 245, 347

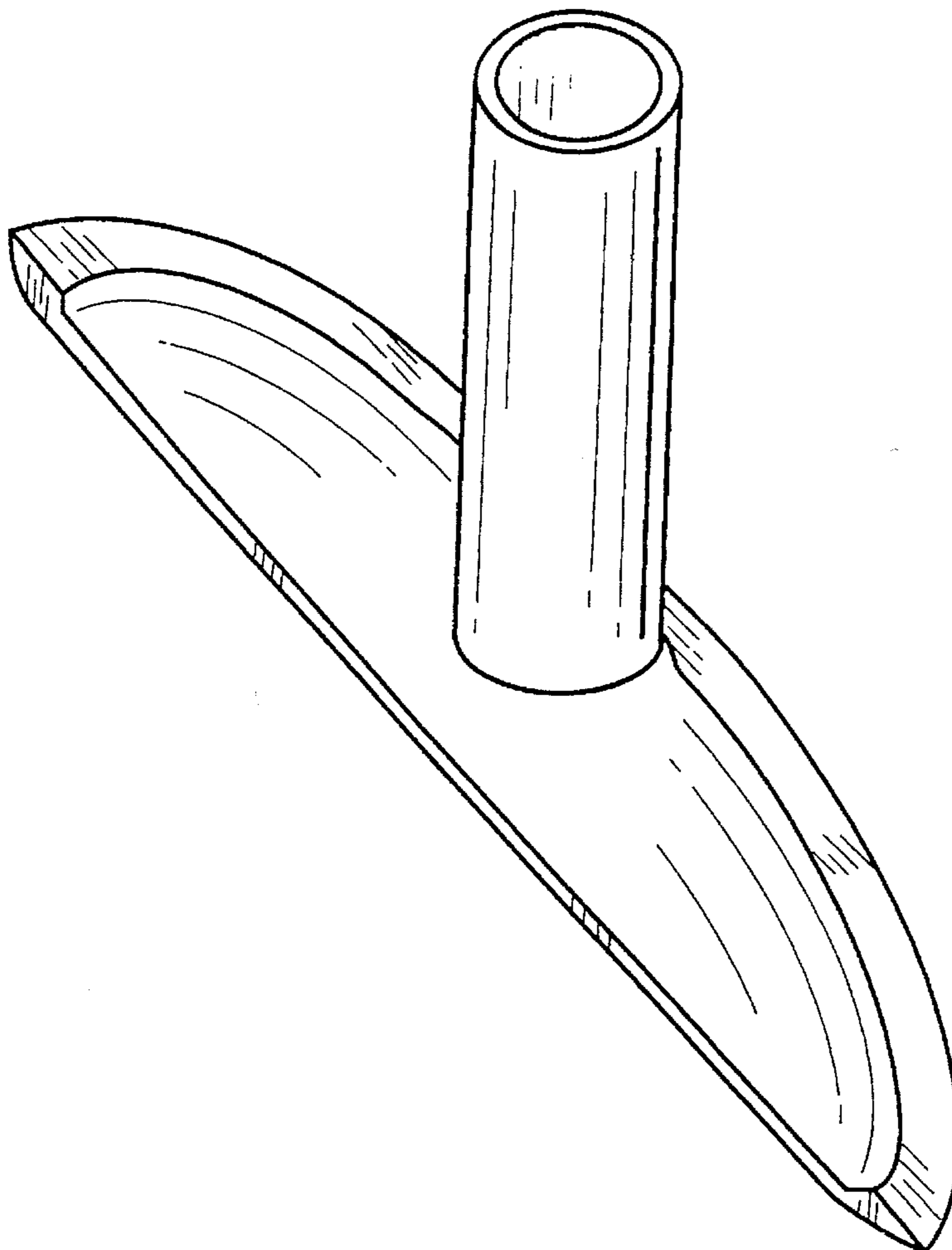
FIG. 1 is a rear perspective view of an air flow friction reducer for watercrafts showing our new design; FIG. 2 is a front perspective view thereof; FIG. 3 is a bottom plan view thereof; FIG. 4 is a top plan view thereof; FIG. 5 is a bottom perspective view thereof; FIG. 6 is a top perspective view thereof; and, FIG. 7 is an exploded perspective view.

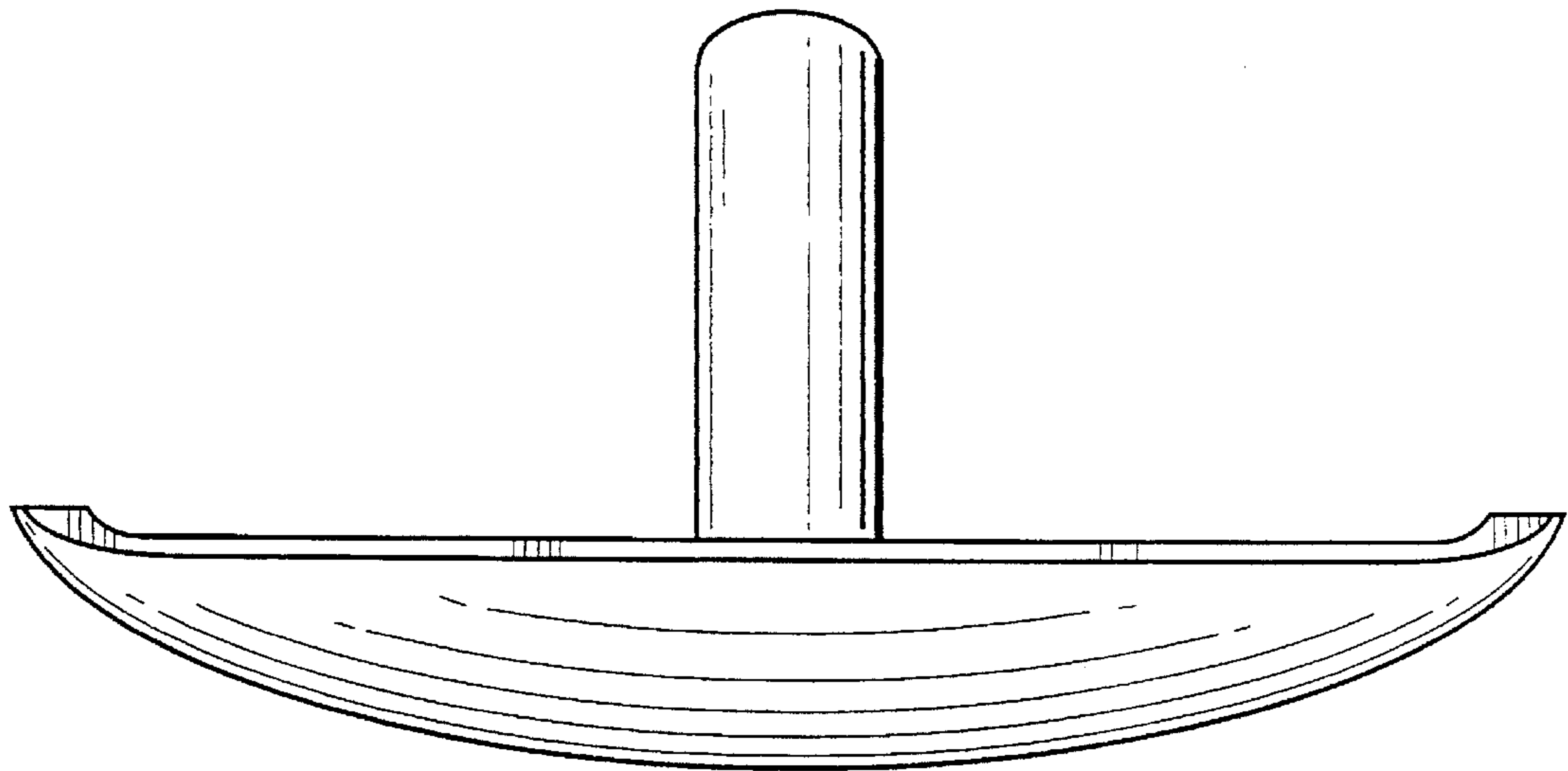
### [56] References Cited

#### U.S. PATENT DOCUMENTS

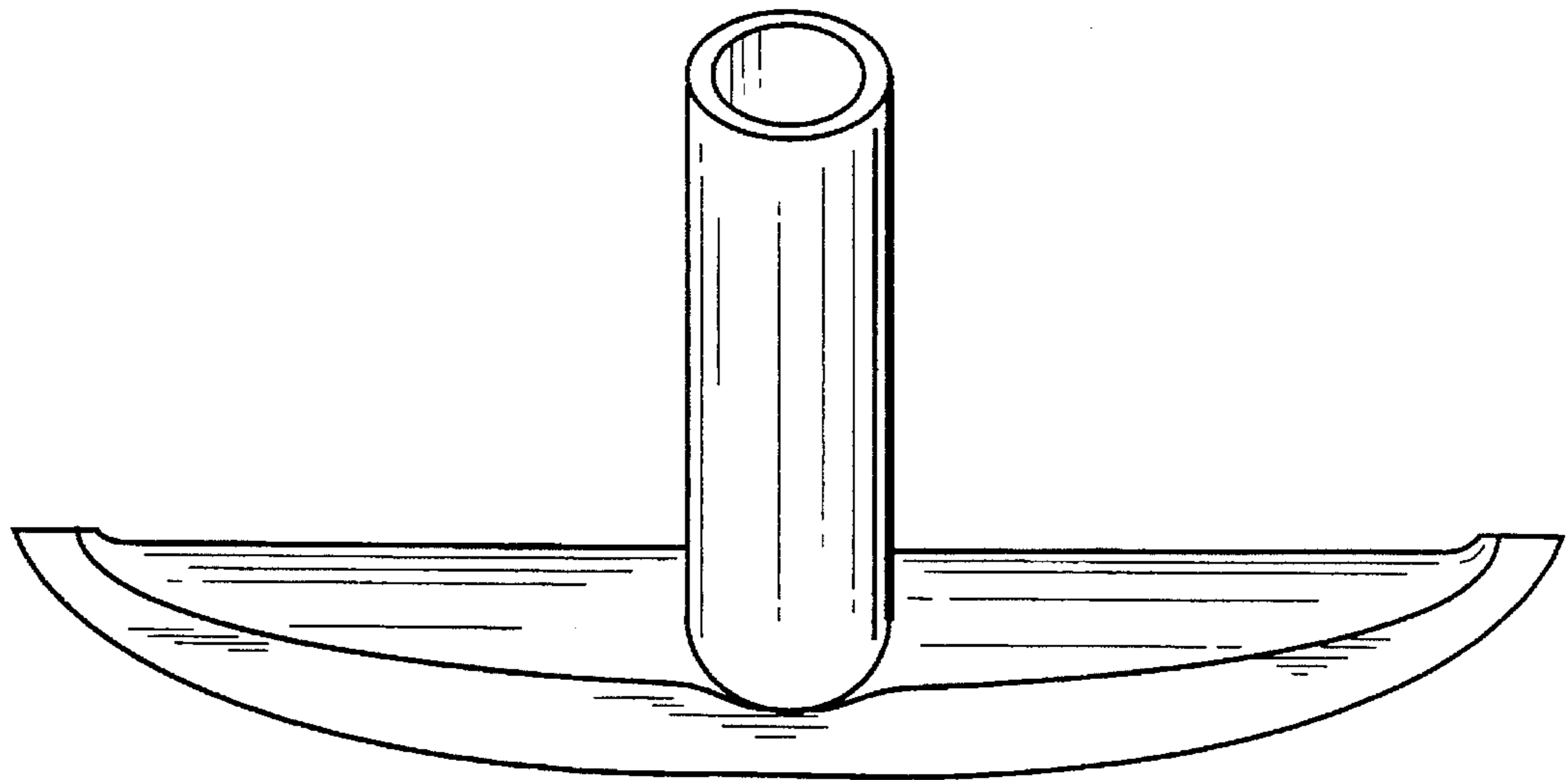
3,753,415 8/1973 Burtis ..... 114/137 X  
4,659,316 4/1987 Ozaki ..... 114/162 X

**1 Claim, 4 Drawing Sheets**

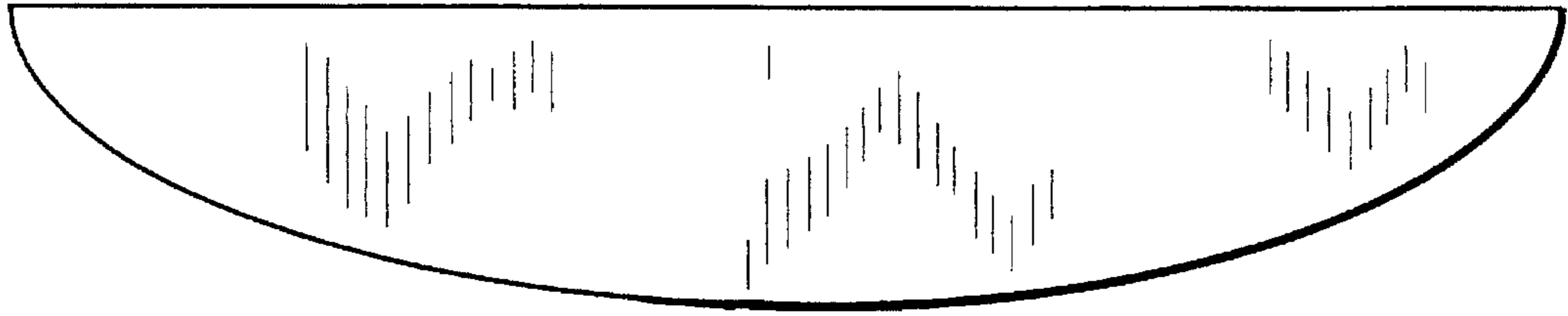




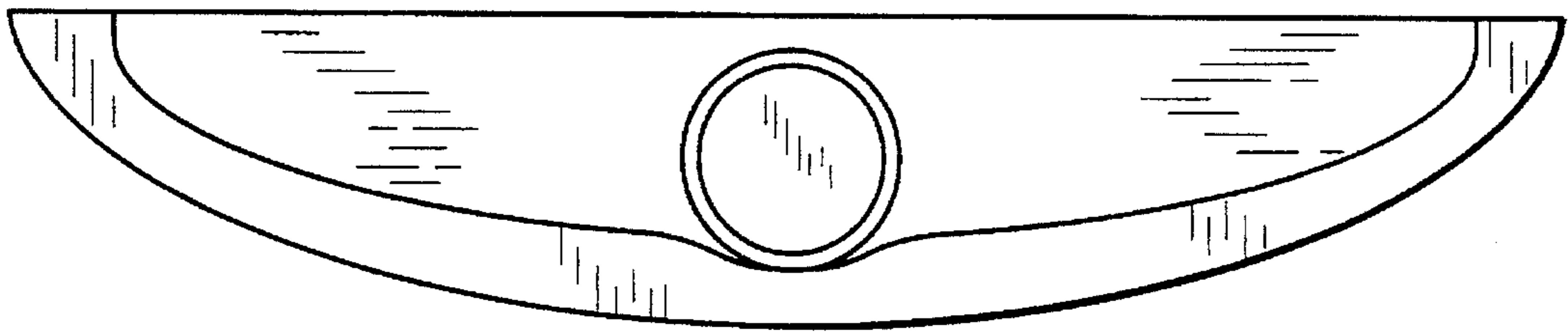
**FIG. 1**



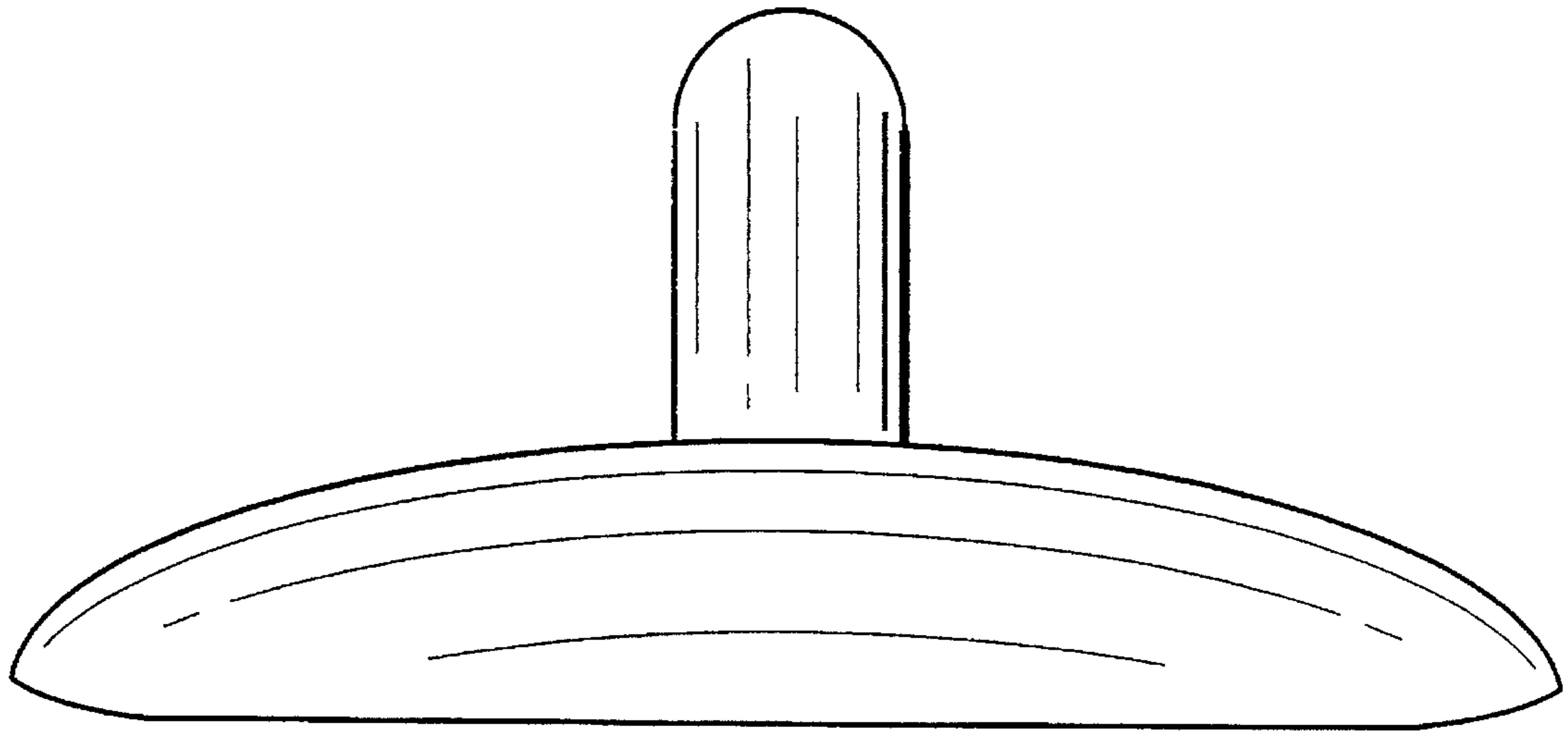
**FIG. 2**



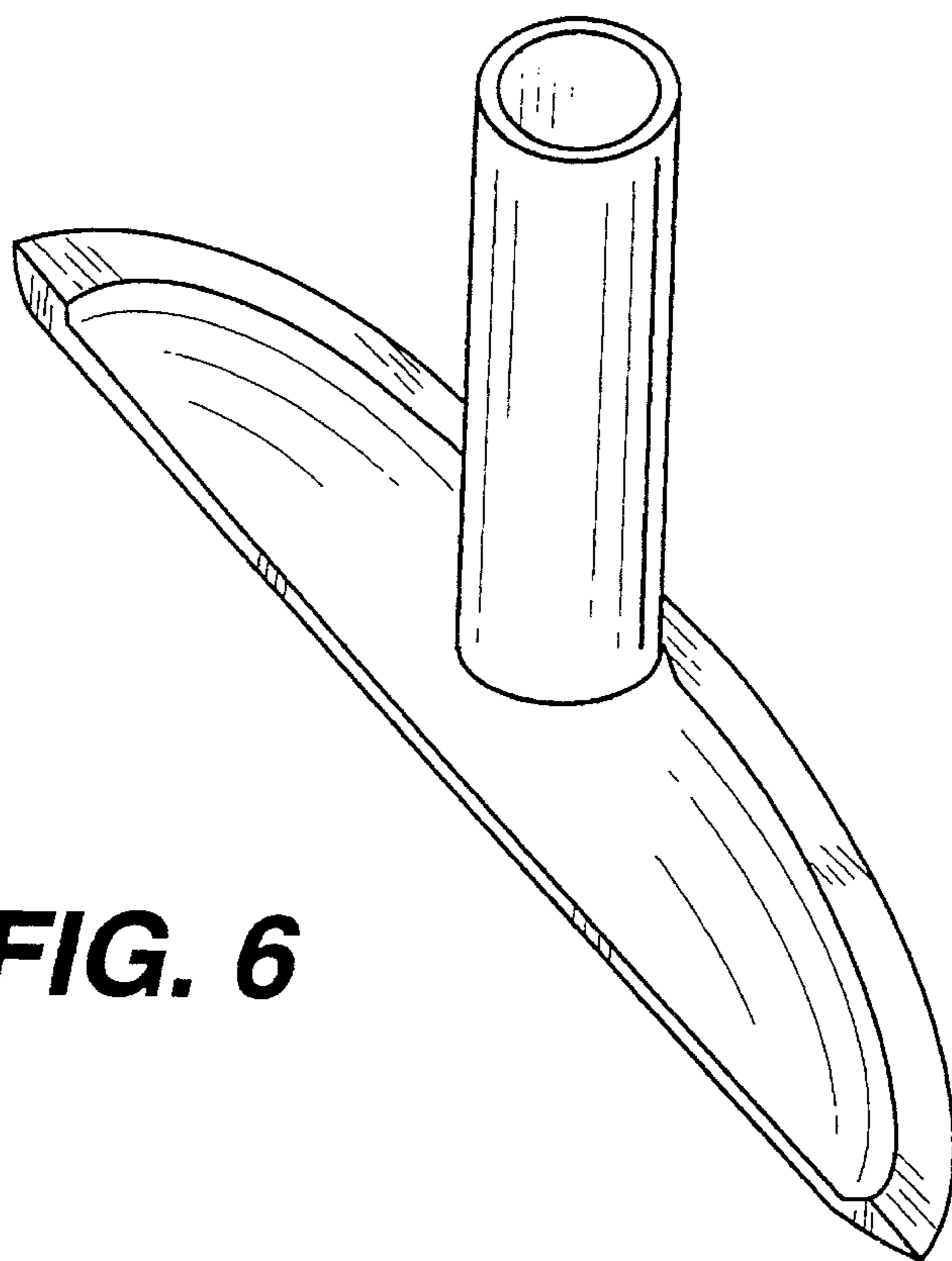
**FIG. 3**



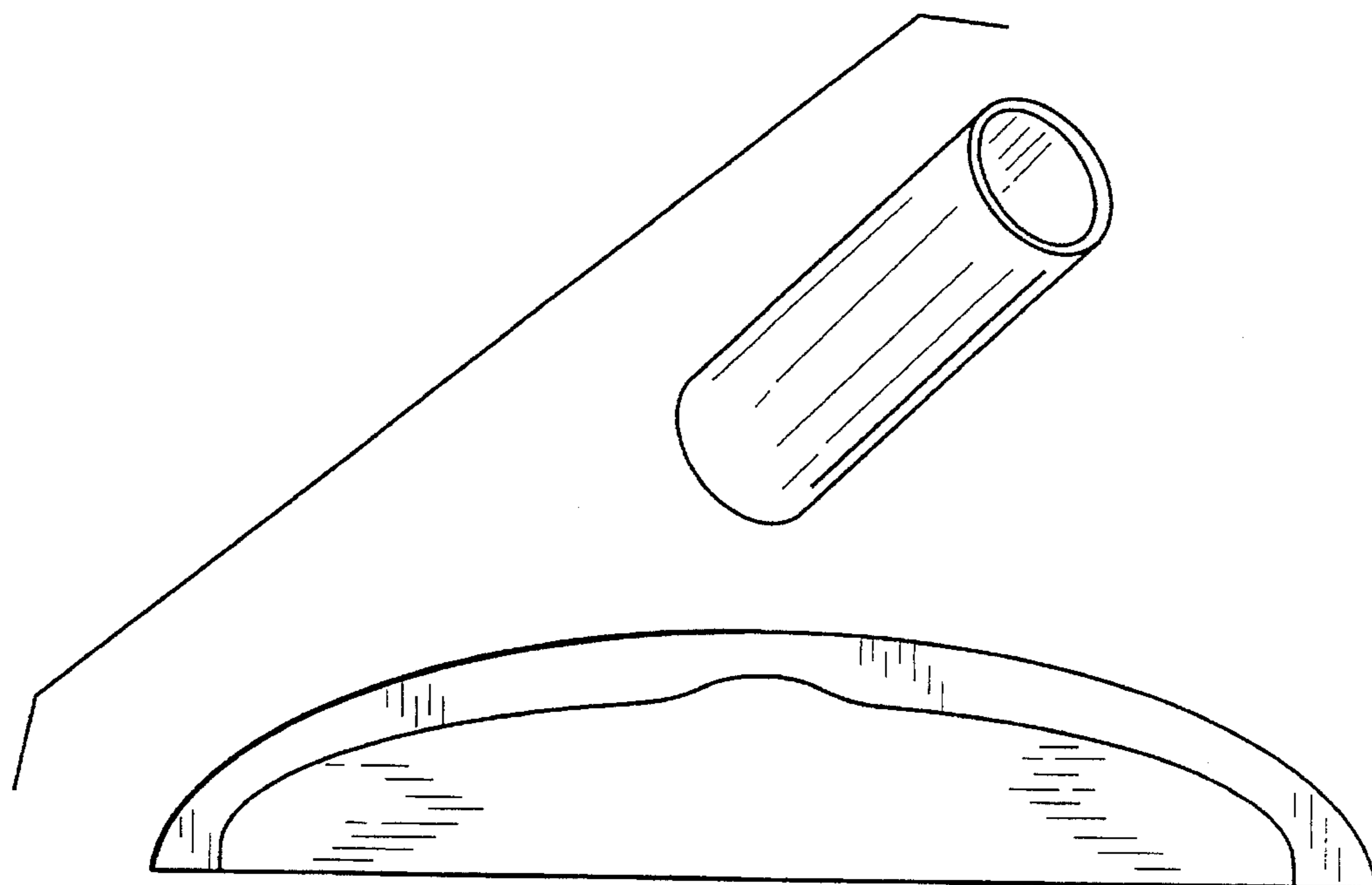
**FIG. 4**



**FIG. 5**



**FIG. 6**



**FIG. 7**