



US00D376571S

# United States Patent [19]

[11] Patent Number: **Des. 376,571**

**Kokat**

[45] Date of Patent: **\*\*Dec. 17, 1996**

[54] **COMBINED AUTOMOBILE EYEGLASS HOLDER AND MIRROR**

D. 344,530	2/1994	Johnson	.....	D12/191
D. 354,471	1/1995	Moseley	.....	D12/191
3,003,396	10/1961	Jenkins	.....	359/868
3,063,344	11/1962	Slate	.....	359/871

[76] Inventor: **John J. Kokat**, 113 Chatsworth Cir., Schaumburg, Ill. 60194

*Primary Examiner*—Melody N. Brown  
*Attorney, Agent, or Firm*—Harpman & Harpman

[\*\*] Term: **14 Years**

[57] **CLAIM**

[21] Appl. No.: **45,821**

The ornamental design for a combined automobile eyeglass holder and mirror, as shown and described.

[22] Filed: **Oct. 31, 1995**

[52] U.S. Cl. .... **D12/187**

**DESCRIPTION**

[58] Field of Search ..... D12/187, 191, D12/188, 407; D16/112; 359/838, 850, 841, 844, 854, 855, 862-868, 871-873, 851; D29/16

FIG. 1 is a front, top and side perspective view of the combined automobile eyeglass holder and mirror embodying the design of the present invention; FIG. 2 is a front elevational view thereof; FIG. 3 is a rear elevational view thereof; FIG. 4 is a side elevational view thereof, the opposite side elevational view being identical thereto; FIG. 5 is a top plan view thereof; and, FIG. 6 is a bottom plan view thereof.

[56] **References Cited**

**U.S. PATENT DOCUMENTS**

D. 281,775	12/1985	Tanaka	.....	D12/187
D. 283,998	5/1986	Tanaka	.....	D12/187
D. 286,036	10/1986	Langensepen	.....	D12/191
D. 310,301	9/1990	Burrow	.....	D12/191
D. 332,246	1/1993	Yeh	.....	D12/187

**1 Claim, 3 Drawing Sheets**

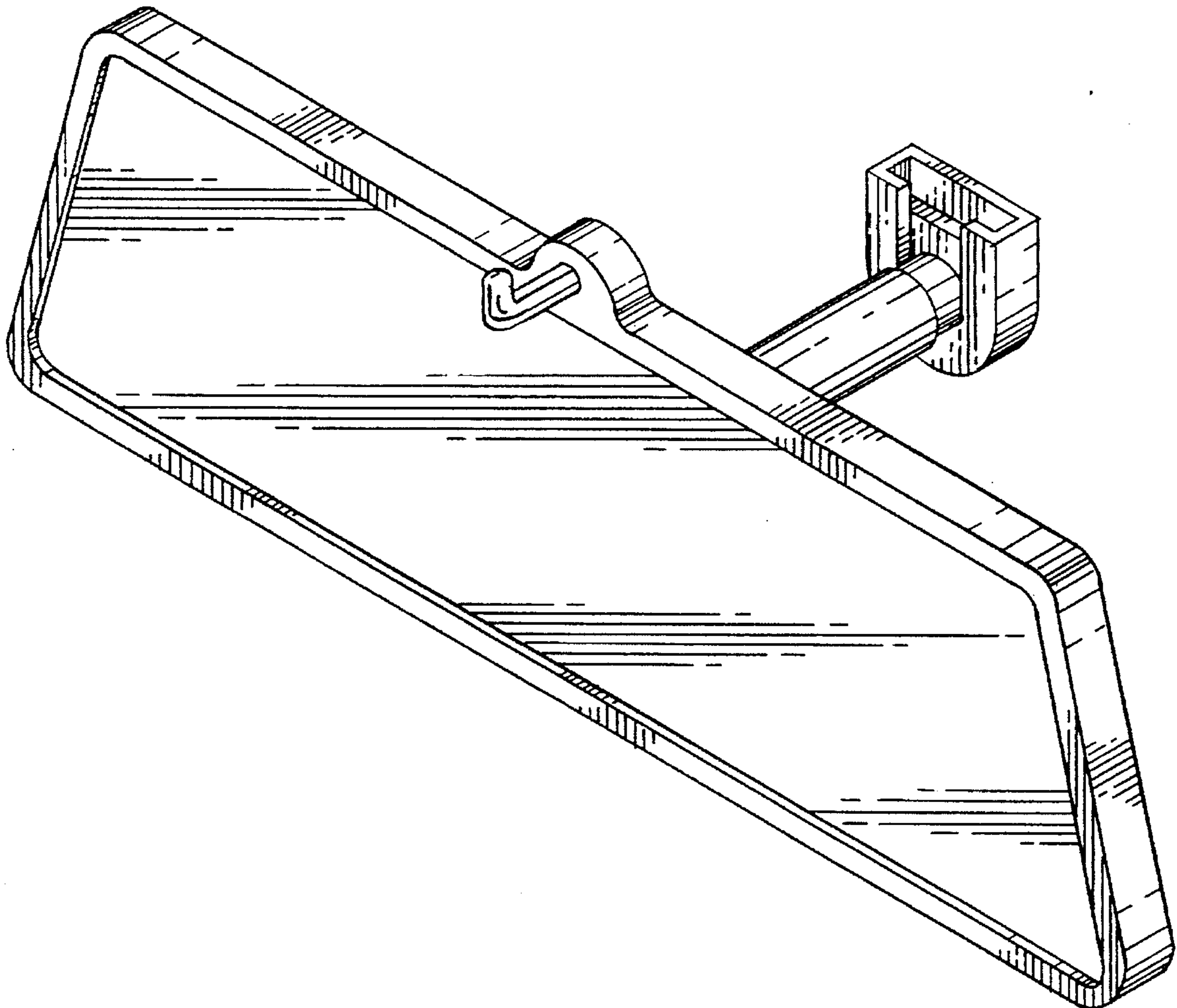

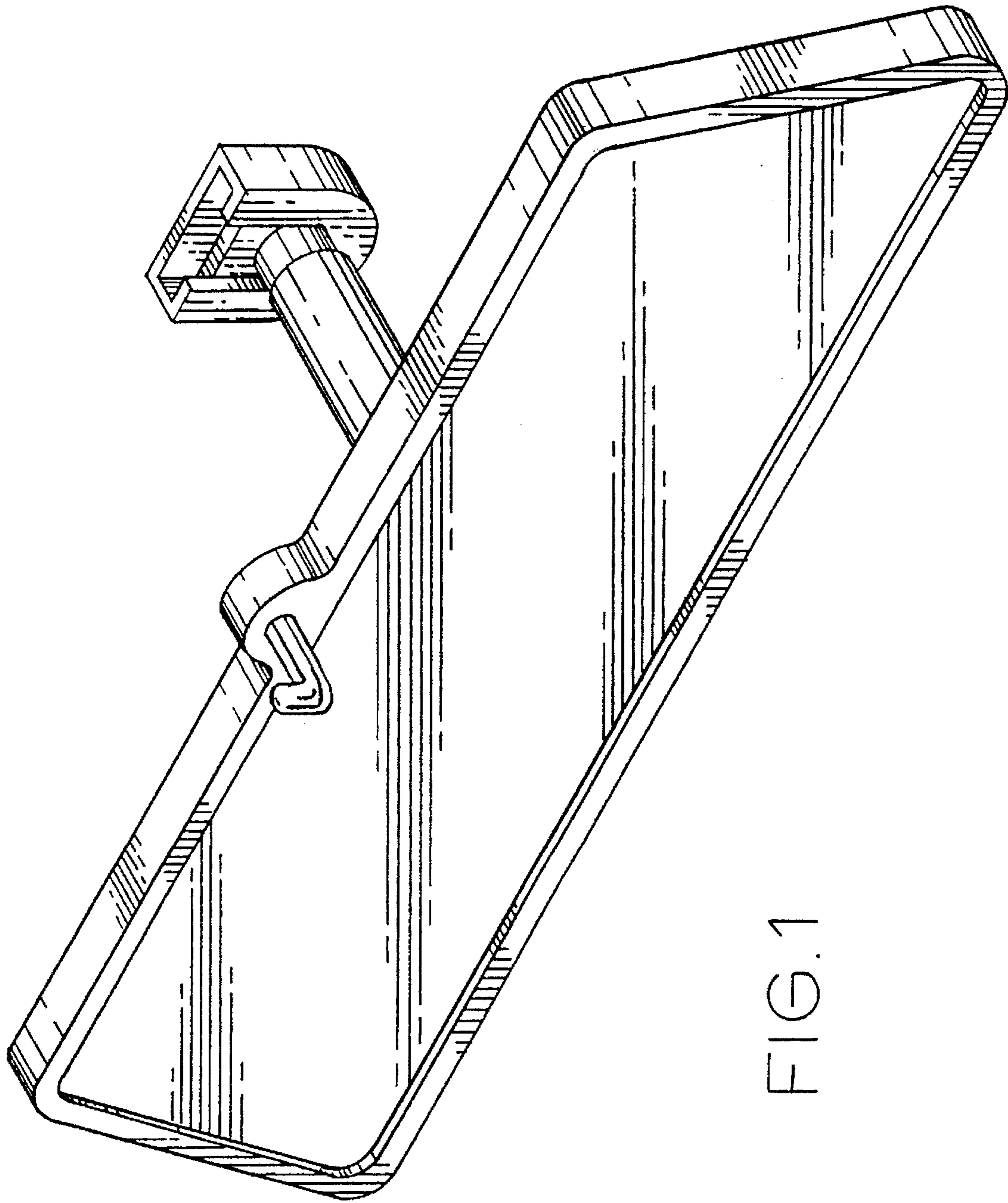

FIG. 1

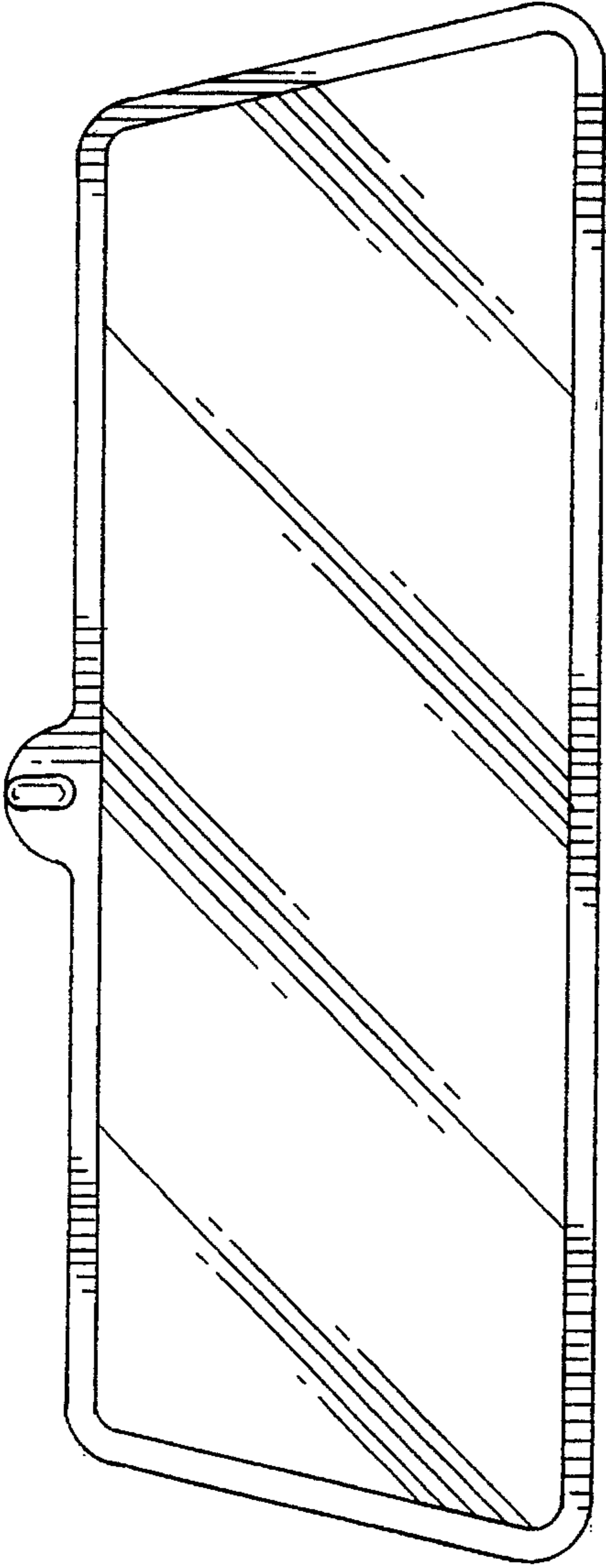

FIG. 2

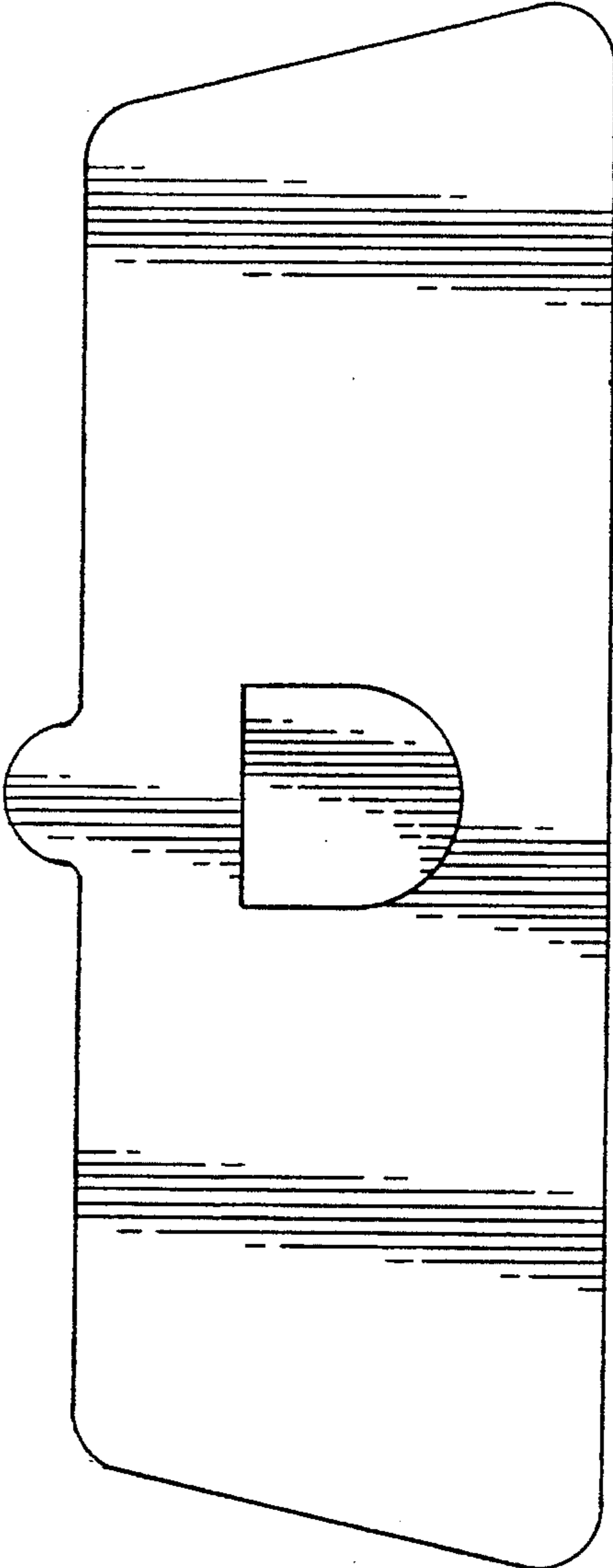

FIG. 3

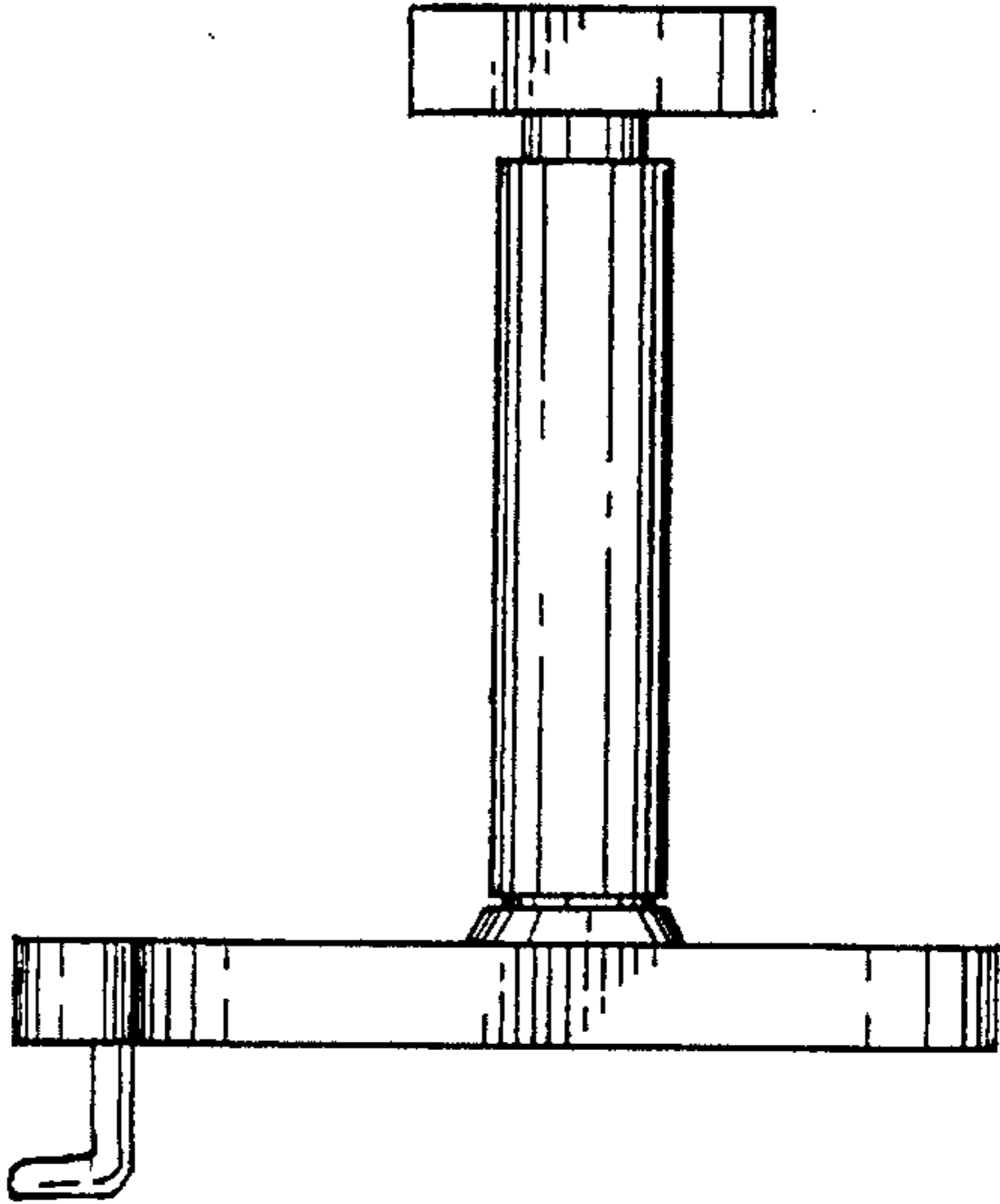

FIG. 4

