



US00D376447S

United States Patent [19]

[11] Patent Number: **Des. 376,447**

Stump

[45] Date of Patent: ****Dec. 10, 1996**

[54] **PET CAR SEAT**

[76] Inventor: **Paula R. Stump**, 2565 Woodberry Dr.,
Winston-Salem, N.C. 27106

[**] Term: **14 Years**

[21] Appl. No.: **44,739**

[22] Filed: **Sep. 22, 1995**

[52] U.S. Cl. **D30/144; D30/118**

[58] Field of Search D30/144, 114;
D12/411, 415-416, 419-420; 119/771,
28.5; D3/260, 118; 220/485, 491; 224/400,
275, 268

[56] **References Cited**

U.S. PATENT DOCUMENTS

D. 151,291	10/1948	Shoemaker et al.	D30/144 X
D. 245,716	9/1977	Russo	D30/41
D. 309,514	7/1990	Marcus et al.	D30/118
1,912,514	6/1933	Curtis et al.	119/28.5
4,463,984	8/1984	Molnar	297/250
4,512,286	4/1985	Rux	119/771 X
4,583,253	4/1986	Hall	5/94
4,597,359	7/1986	Moorman	119/28.5
4,676,198	6/1987	Murray	119/96
4,715,618	12/1987	Harris	280/180
4,834,420	5/1989	Sankrithi et al.	280/728
4,896,630	1/1990	Luce	119/96
5,123,377	6/1992	Edwards	119/28.5

5,133,294	7/1992	Reid	119/771
5,147,109	9/1992	Jolly	297/217
5,305,710	4/1994	Ward, Jr.	119/771
5,385,385	1/1995	Silverman	297/250.1
5,479,892	1/1996	Edwards	119/771

Primary Examiner—B. J. Bullock
Assistant Examiner—Stacia Sinuik
Attorney, Agent, or Firm—Rhodes Coats & Bennett, L.L.P.

[57] **CLAIM**

The ornamental design for a pet car seat, as shown and described.

DESCRIPTION

FIG. 1 is a front perspective view of a pet car seat showing my new design;
FIG. 2 is a side elevational view thereof;
FIG. 3 is a front elevational view thereof;
FIG. 4 is a rear elevational view thereof;
FIG. 5 is a top view thereof;
FIG. 6 is a front perspective view of a second embodiment of the pet car seat shown in FIG. 1, the only difference being one of proportion. The dashed lines are environmental elements only and form no part of the claimed design; and,
FIG. 7 is a front perspective view of a third embodiment of the pet car seat shown in FIG. 1, the only difference being the inclusion of a pad the size of which conforms to the size of the bottom of the pet car seat.

1 Claim, 4 Drawing Sheets

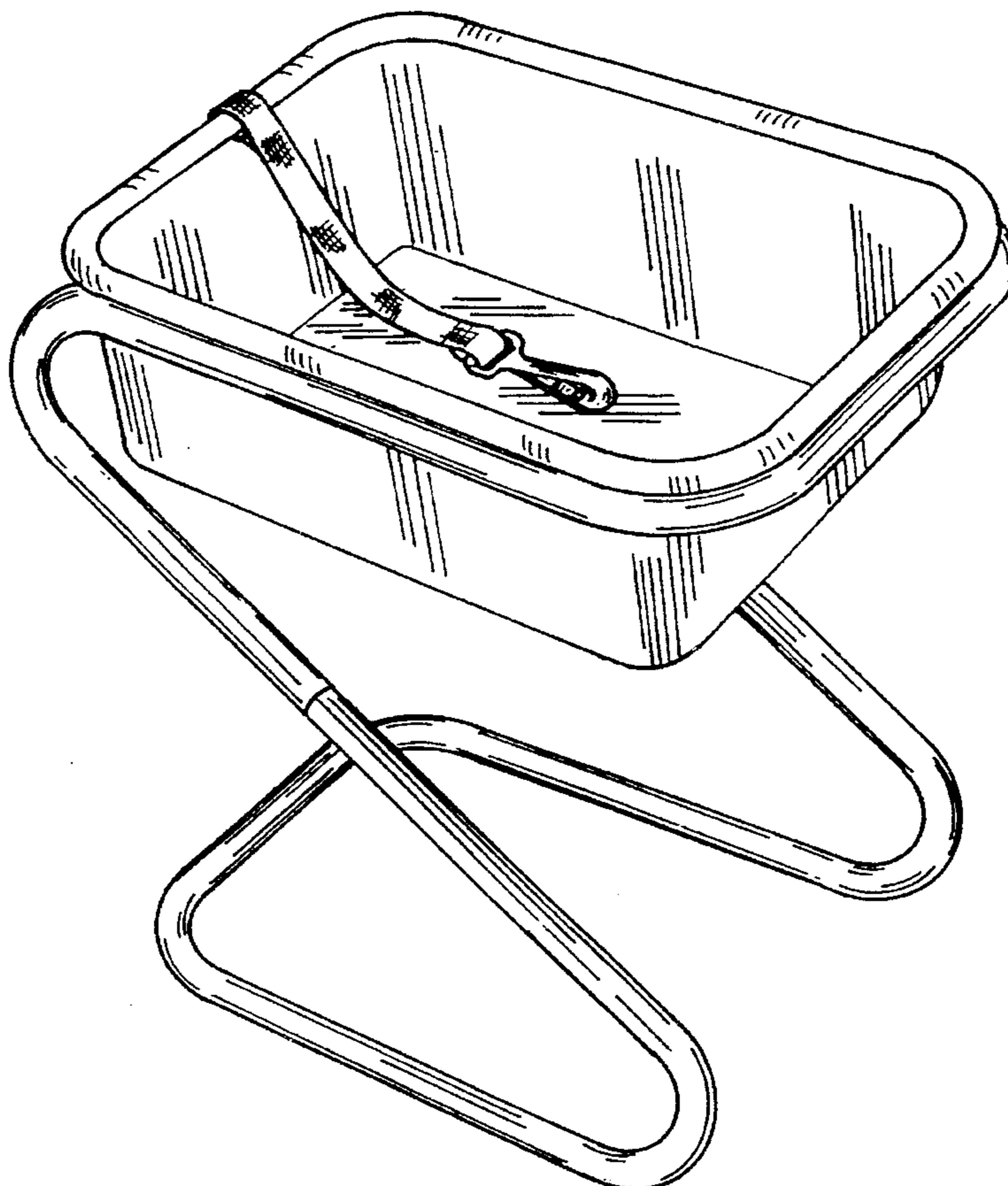

FIG. 2

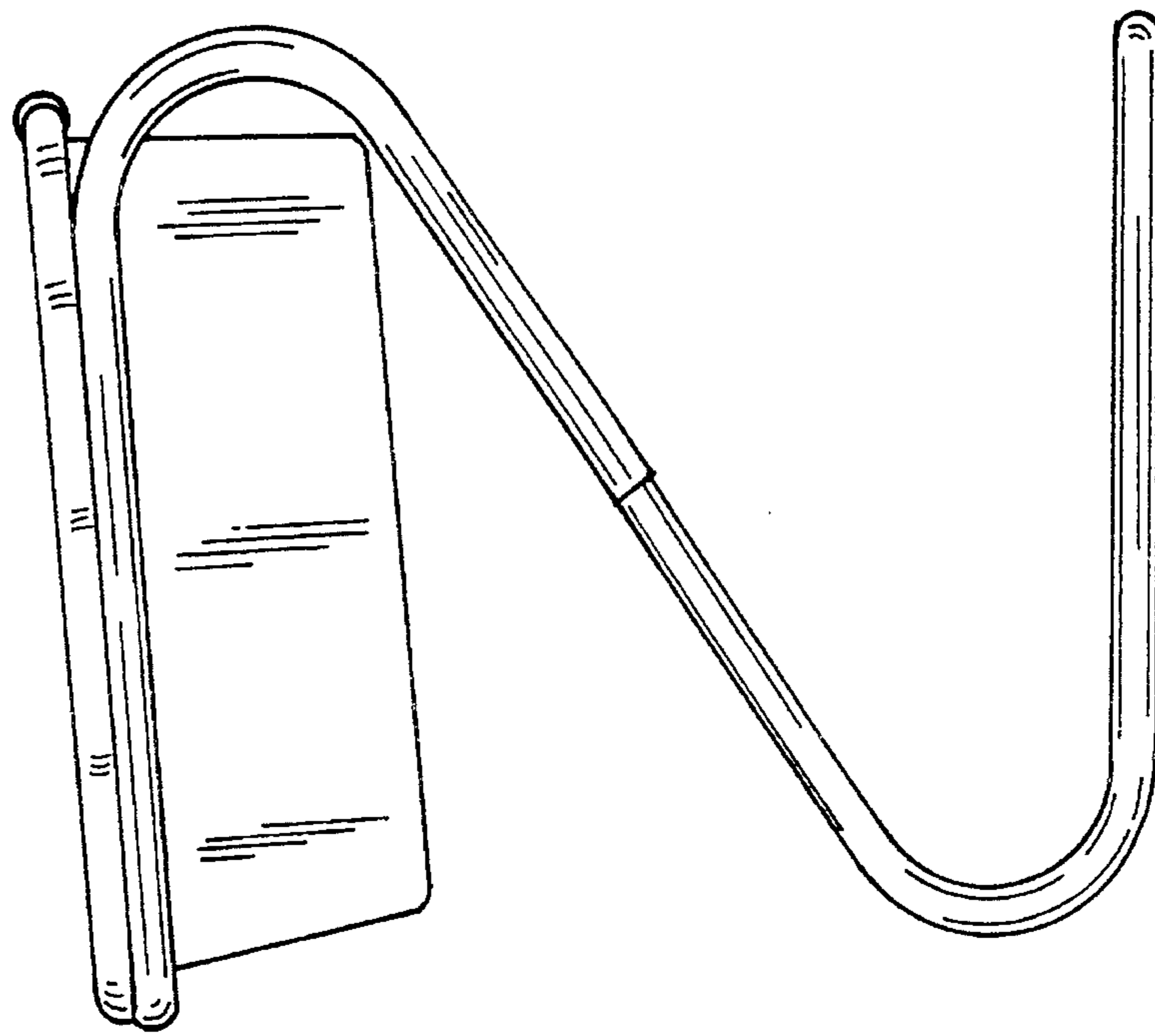
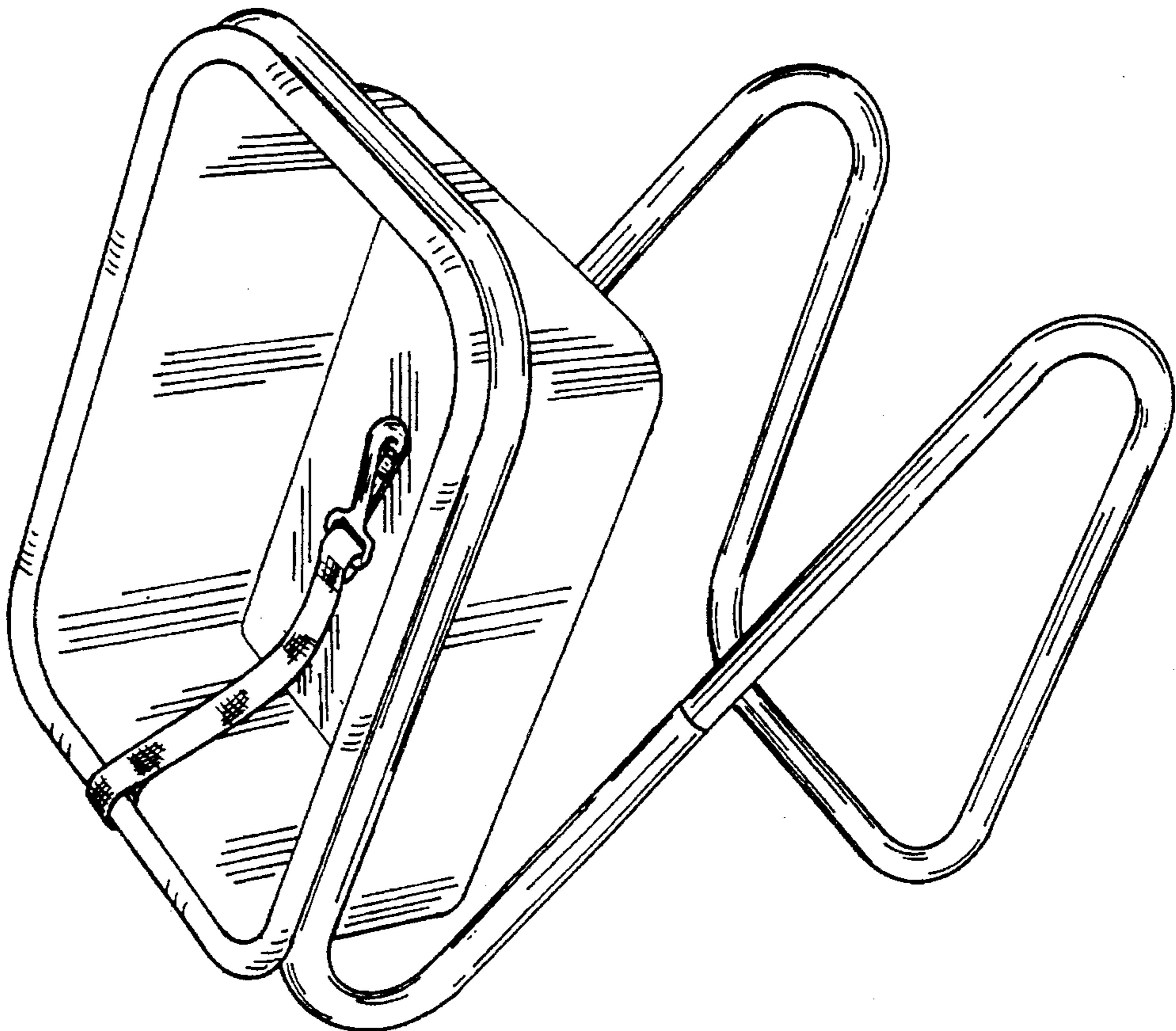

FIG. 1



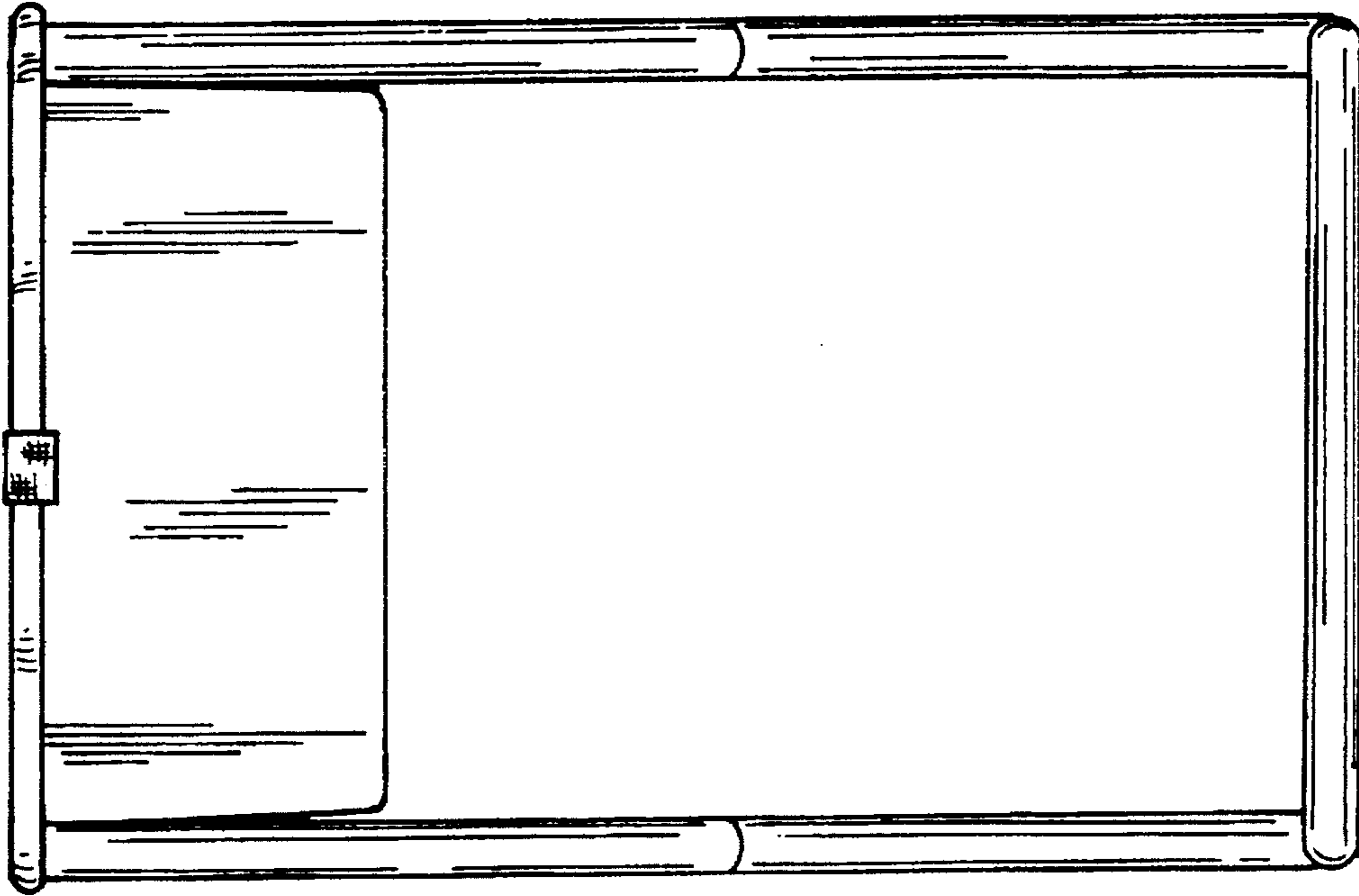

FIG. 4

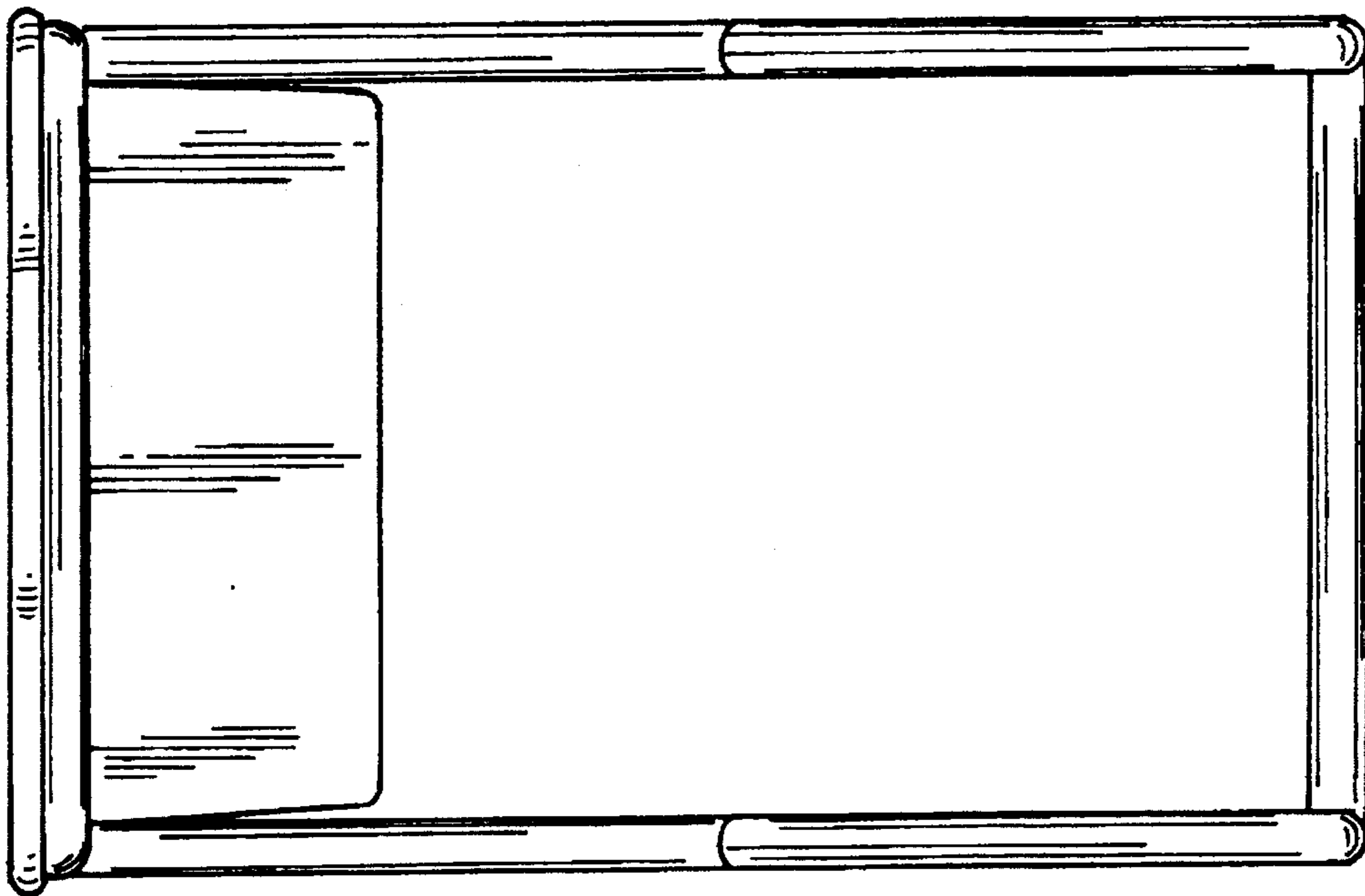

FIG. 3

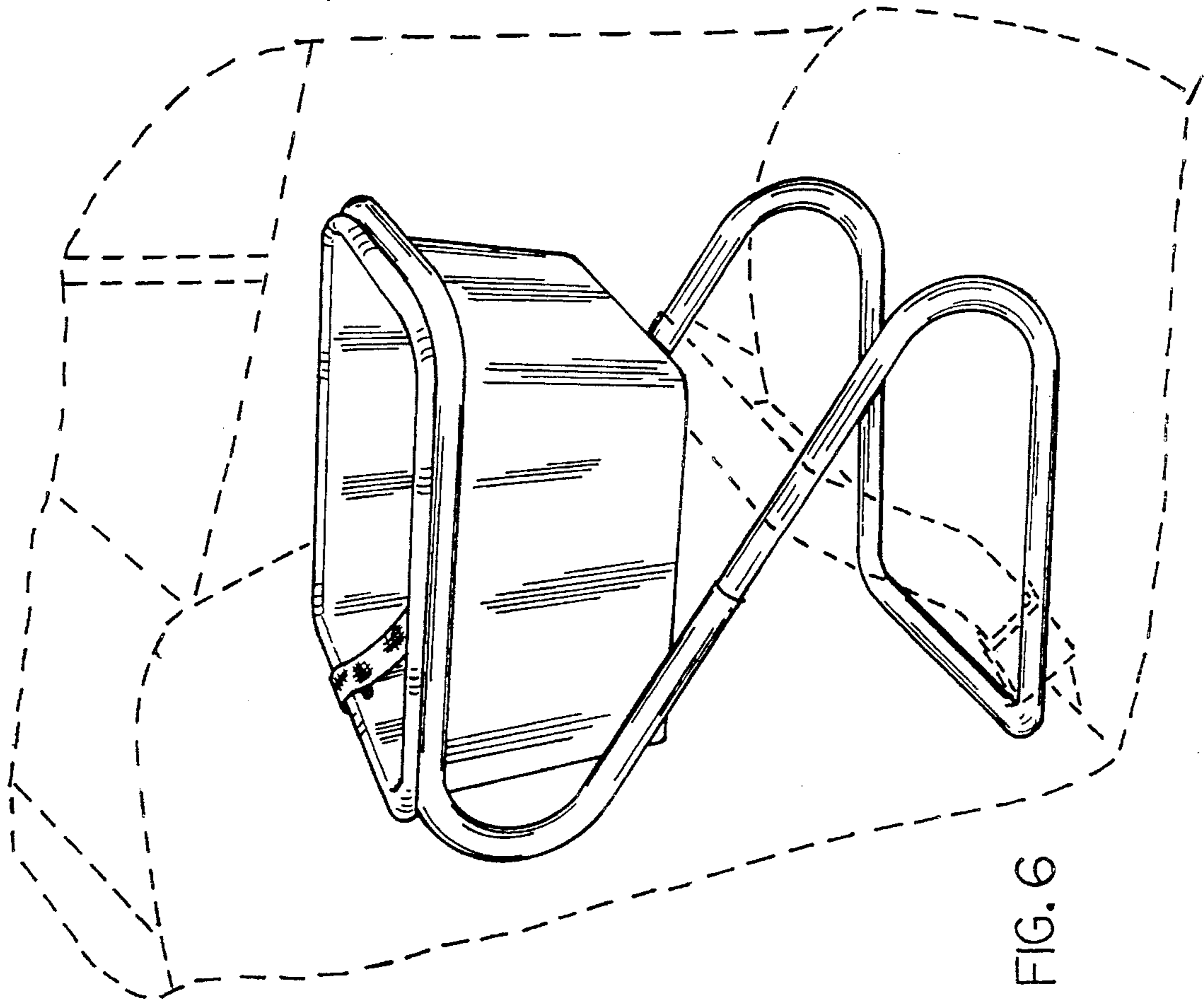

FIG. 6

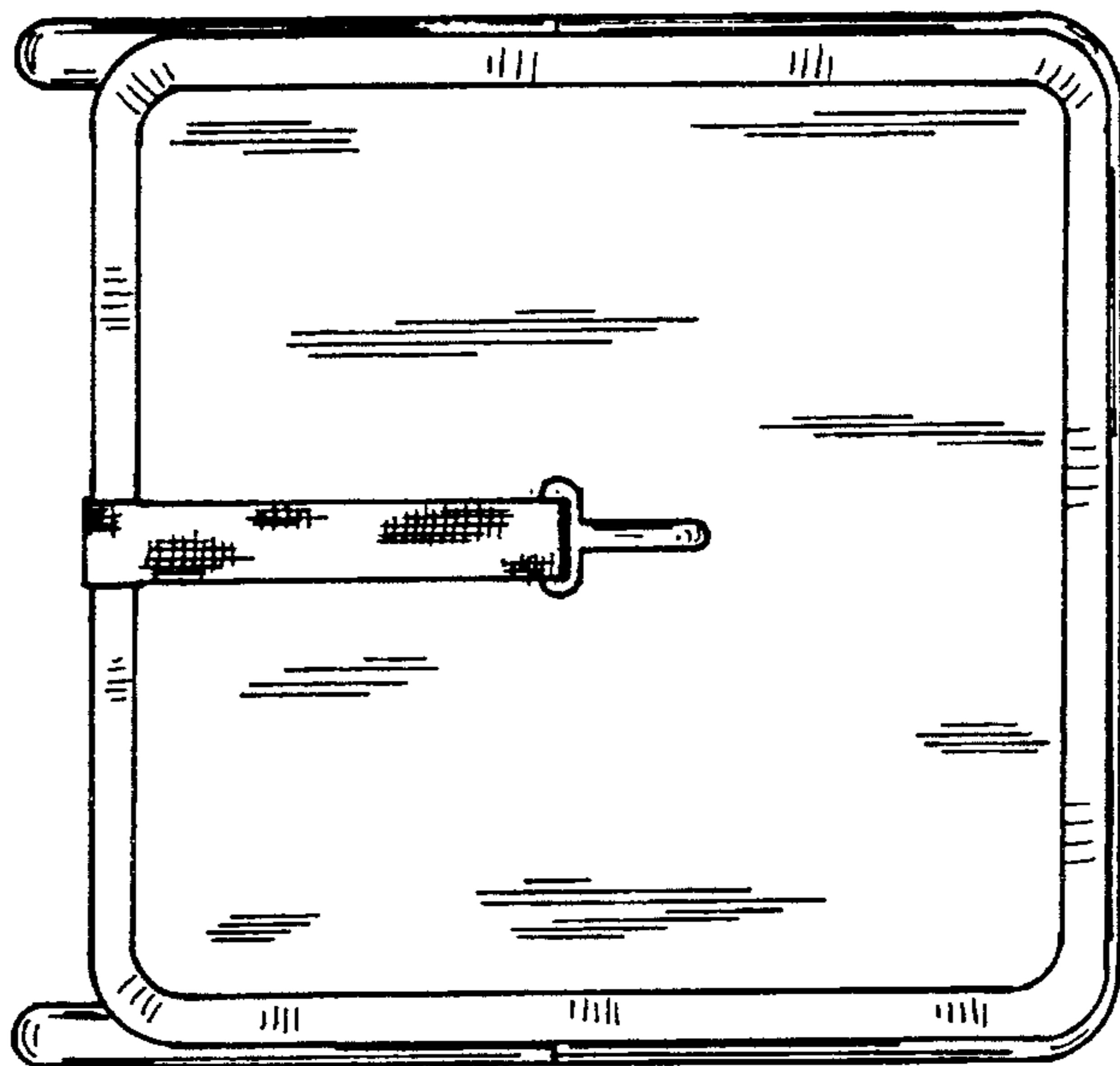

FIG. 5

FIG. 7

