



US00D376337S

# United States Patent [19]

[11] Patent Number: **Des. 376,337**

**Camfield**

[45] Date of Patent: **\*\*Dec. 10, 1996**

[54] **BICYCLE**

[75] Inventor: **David K. Camfield, Olney, Ill.**

[73] Assignee: **Roadmaster Corporation, Olney, Ill.**

[\*\*] Term: **14 Years**

[21] Appl. No.: **15,109**

[22] Filed: **Nov. 8, 1993**

[52] U.S. Cl. .... **D12/111**

[58] Field of Search ..... D12/111; 280/281.1,  
280/288.1, 288.2, 288.3

[56] **References Cited**

**U.S. PATENT DOCUMENTS**

D. 93,008	8/1934	Ely .....	D12/111
D. 138,304	7/1944	Boynton .....	D12/111
D. 166,693	9/1951	Lines .....	D12/111
D. 170,610	10/1953	Sebel .....	D12/111
D. 203,146	12/1965	Ryan .....	D12/111
D. 240,418	7/1976	Herano et al. ....	D12/111
D. 243,754	3/1977	Silva, Jr. ....	D12/111
D. 245,002	7/1977	Carpenter et al. ....	D12/111
D. 267,560	1/1983	Matsue .....	D12/110
D. 270,047	8/1983	Kataoka et al. ....	D12/110
D. 273,100	3/1984	Ziegler .....	D12/111
D. 273,854	5/1984	Ishiyama .....	D12/110
D. 275,469	9/1984	Morioka et al. ....	D12/110
D. 291,187	8/1987	Smith et al. ....	D12/111
D. 291,291	8/1987	Voytko et al. ....	D12/111
D. 291,292	8/1987	Smith et al. ....	D12/111
D. 294,338	2/1988	Yamada et al. ....	D12/110
D. 299,016	12/1988	Kitagawa et al. ....	D12/110
D. 299,447	1/1989	Sakuma et al. ....	D12/110
D. 299,816	2/1989	Maruyama et al. ....	D12/110
D. 311,507	10/1990	Sasaki .....	D12/110
D. 312,807	12/1990	Kohama et al. ....	D12/110
D. 314,167	1/1991	Kolter et al. ....	D12/110
D. 321,849	11/1991	Abe et al. ....	D12/110
D. 326,247	5/1992	Hess .....	D12/110
D. 329,625	9/1992	Mueller .....	D12/111
D. 332,588	1/1993	Kohama et al. ....	D12/110
D. 333,641	3/1993	Sakaguchi et al. ....	D12/110
D. 337,973	8/1993	Mariol .....	D12/112
D. 342,702	12/1993	Camfield et al. ....	D12/111
D. 343,810	2/1994	Sanborn .....	D12/111
D. 345,325	3/1994	Camfield et al. ....	D12/111

D. 346,138	4/1994	Camfield et al. ....	D12/111
D. 350,087	8/1994	Sanborn .....	D12/111
3,690,721	9/1972	Herbert .....	296/78.1
4,022,487	5/1977	Leahy .....	280/288.4
4,534,578	8/1985	Keller .....	280/281.1
4,739,851	4/1988	Perego .....	180/65.1
4,776,422	10/1988	Sakuma .....	180/219
4,906,086	3/1990	Imai et al. ....	180/219

**OTHER PUBLICATIONS**

- Brochure, Honda "1991 VFR750F".
- Brochure, Honda "1991 CBR600F2".
- Brochure, Honda "1991 XR200R, XR100R, XR80R and Z50R".
- Catalogue, FAO Schwartz, Fifth Avenue, The Ultimate Toy Catalogue, Fall 1993 (See p. 1, item "G"; p. 2, item E).
- Catalogue, Hedstrom-1985 (See Models 9-5031, 9-5001, 9-5051).
- Catalogue, AMF, Evel Knievel Line, Spirited New Evel Knievel Styles for 1976 (See Models L-9240, E-992, E-966).
- Catalogue, AMF, Junior, 1977 Juvenile Wheel Goods (See Models G-992, G-986).
- Catalogue, AMF, Roadmaster, Bicycles for 1977 (See Models M-9224, M-9226, M-9234).

(List continued on next page.)

*Primary Examiner*—Melody N. Brown  
*Attorney, Agent, or Firm*—Brinks Hofer Gilson & Lione

[57] **CLAIM**

The ornamental design for a bicycle, as shown and described.

**DESCRIPTION**

FIG. 1 is a left side and front perspective view of a bicycle showing my new design;  
 FIG. 2 is a left side elevational view thereof;  
 FIG. 3 is a right side elevational view thereof;  
 FIG. 4 is a front elevational view thereof;  
 FIG. 5 is a rear elevational view thereof;  
 FIG. 6 is a top plan view thereof; and,  
 FIG. 7 is a bottom plan view thereof.

**1 Claim, 6 Drawing Sheets**

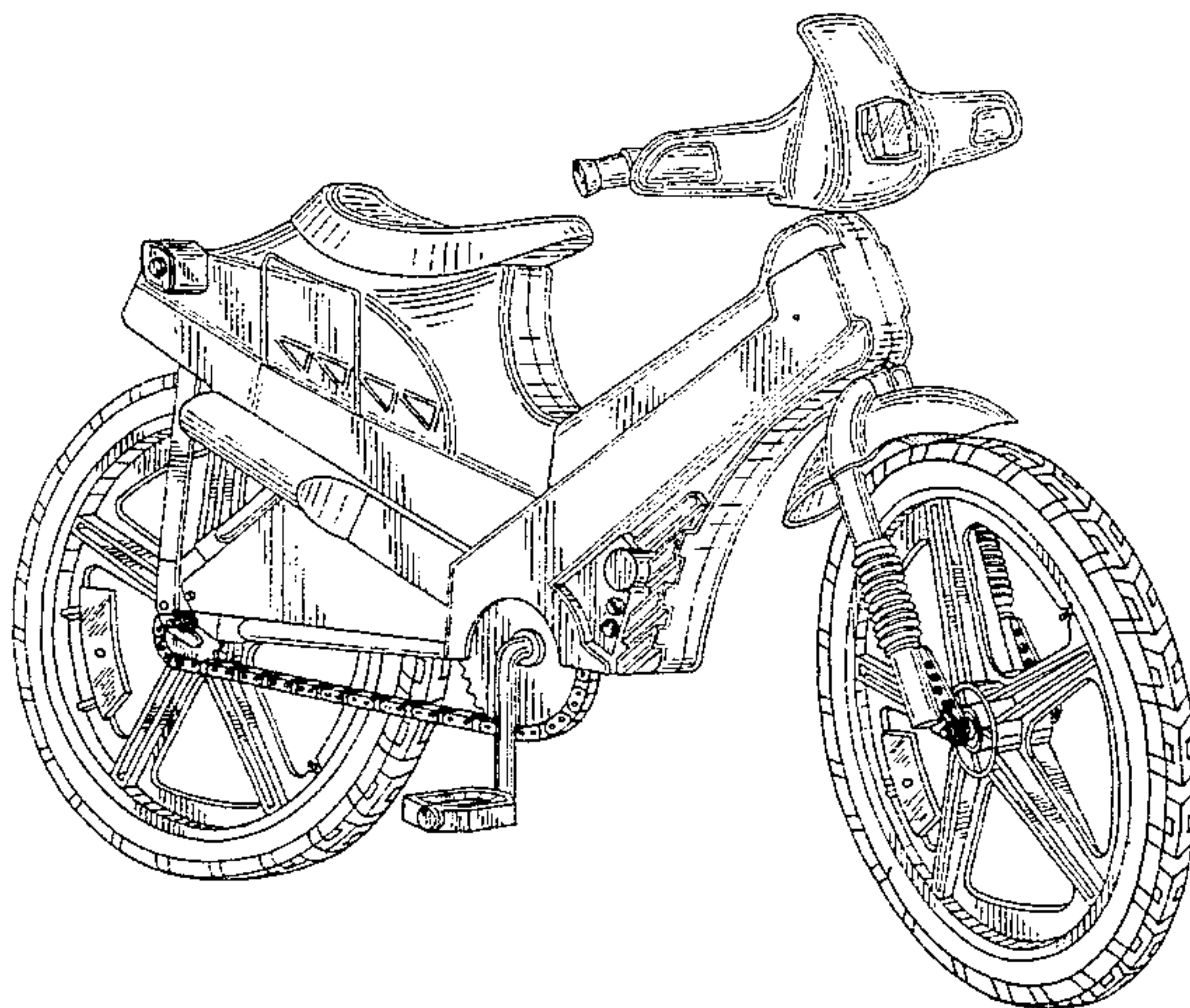

OTHER PUBLICATIONS

Catalogue, AMF, 1978 Juvenile Wheel Goods (See Models A-992, A-905).

Catalogue, AMF, Roadmaster, Bicycles for 1978 (See Models P-9240, P-9216, P-9234, P-9231, P-9212, P-9232, P-9214).

Catalogue, AMF, Junior, Wheel Goods for 1979 (See Model B-905).

Catalogue, AMF, Roadmaster, Bicycles for 1979 (See Models R-9214, R-9222, R-9234, R-9290, R-9238).

Catalogue, Bicycles for 1975 (See Models K-9234, K-9232).

Catalogue, AMF, Junior, 1976 Juvenile Wheel Goods (See Model E-986).

Catalogue, AMF, Roadmaster, Bicycles for 1976 (See Models L-9230, L-9231, L-9234, L-9238, L-9236).

Des. App. Ser. No. 07/896,543.

Catalogue, FAMOPLAY, circa 1993, at pp. 11-12.



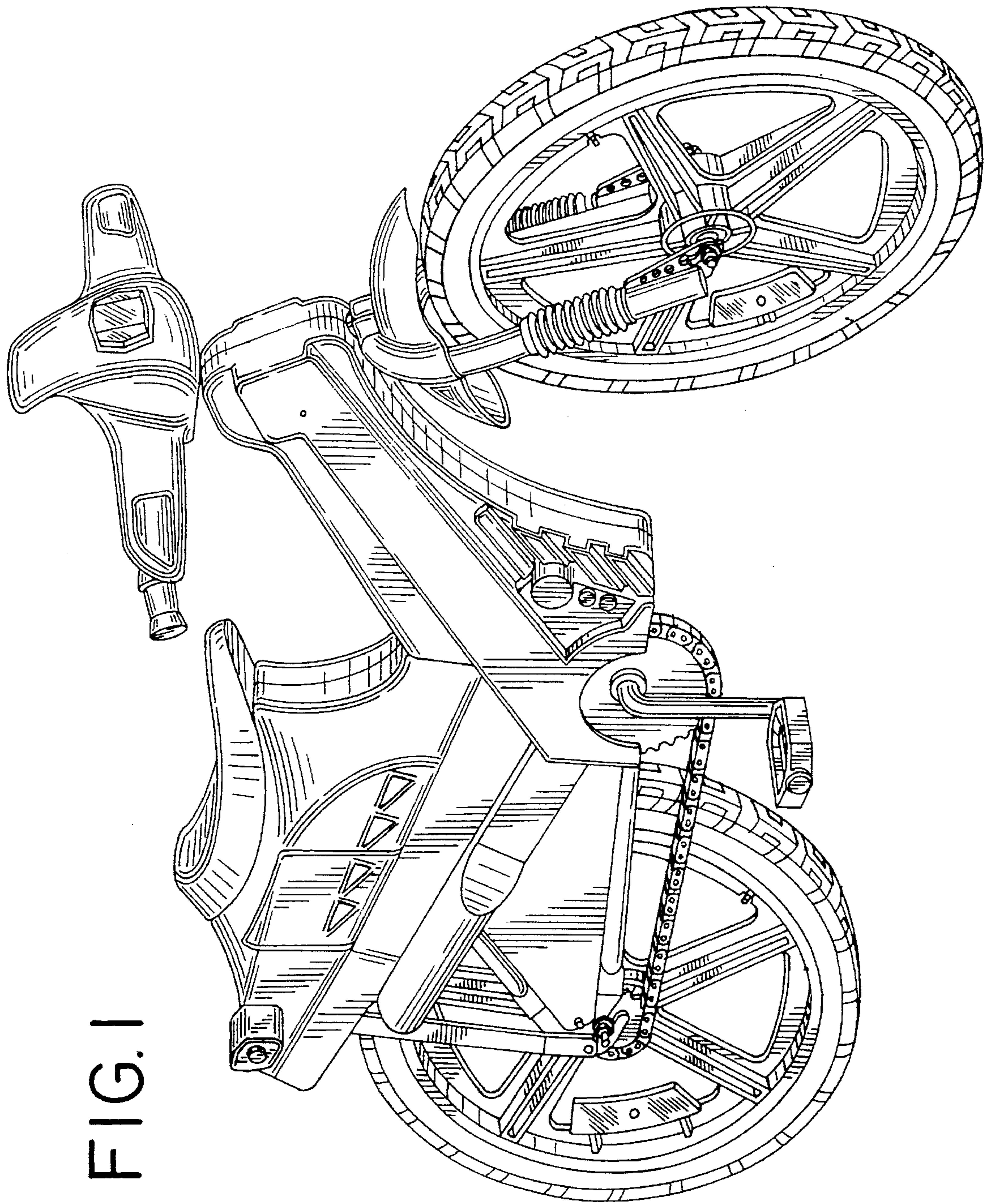

FIG. 1



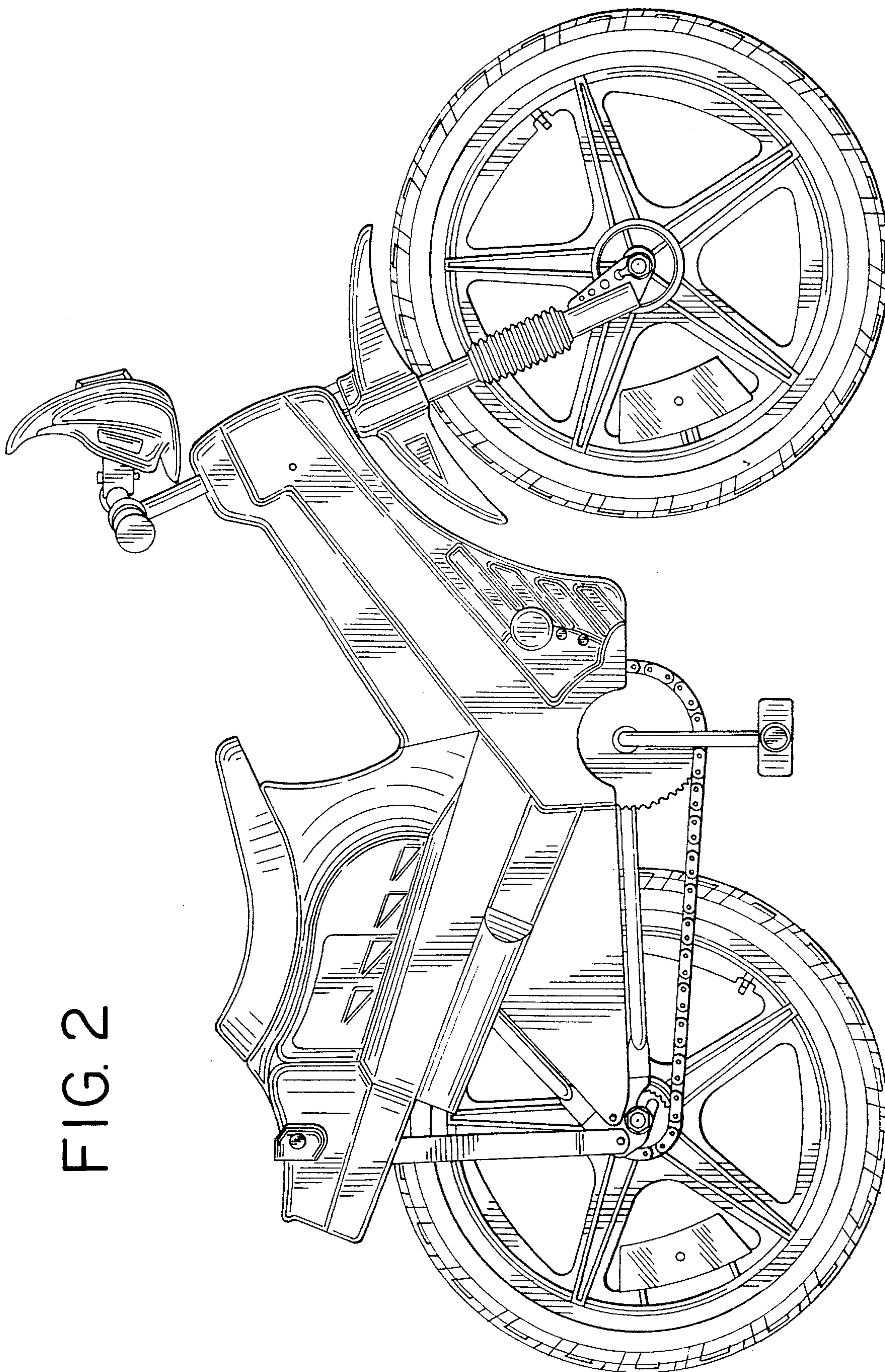

FIG. 2



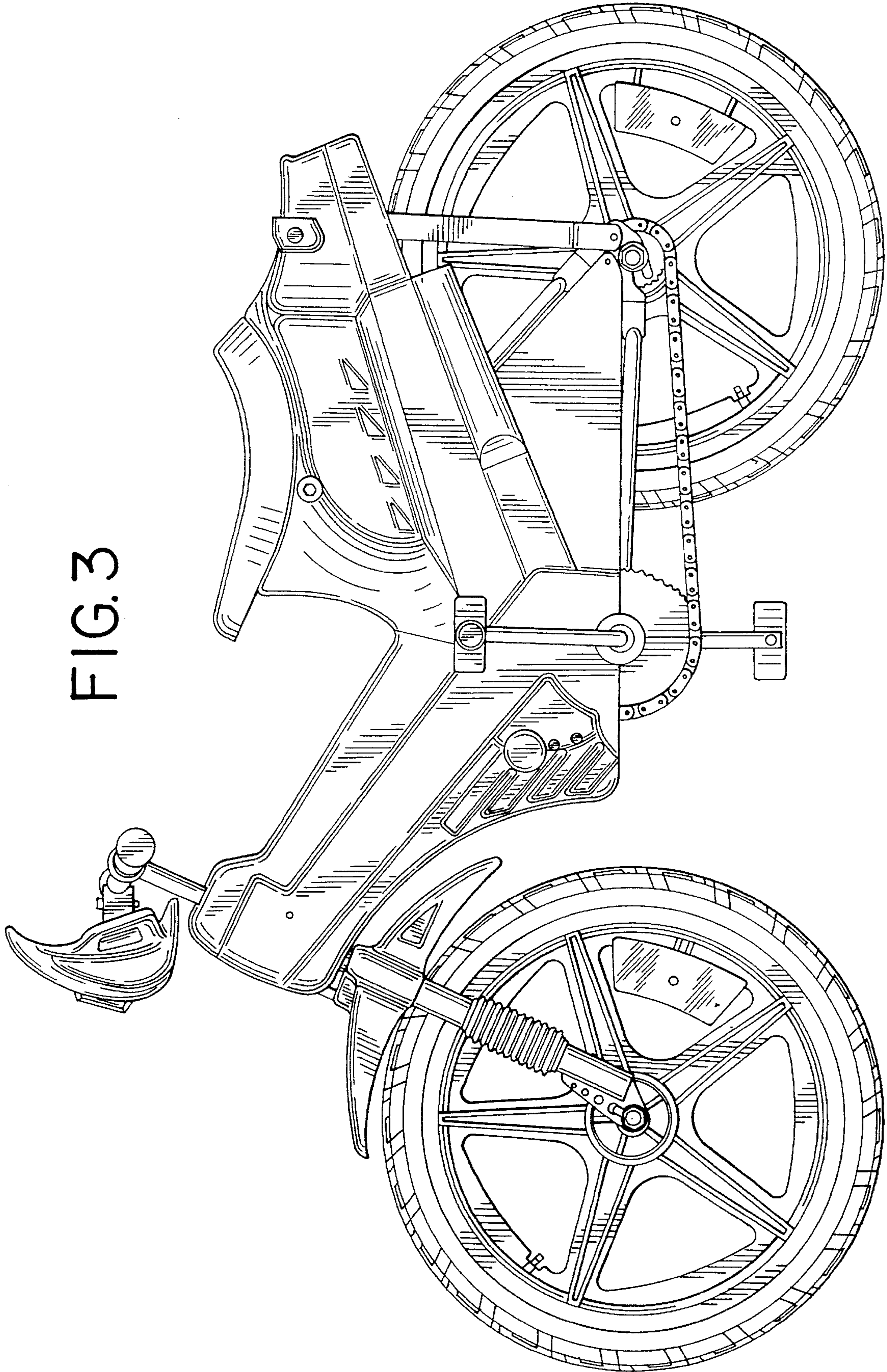

FIG. 3

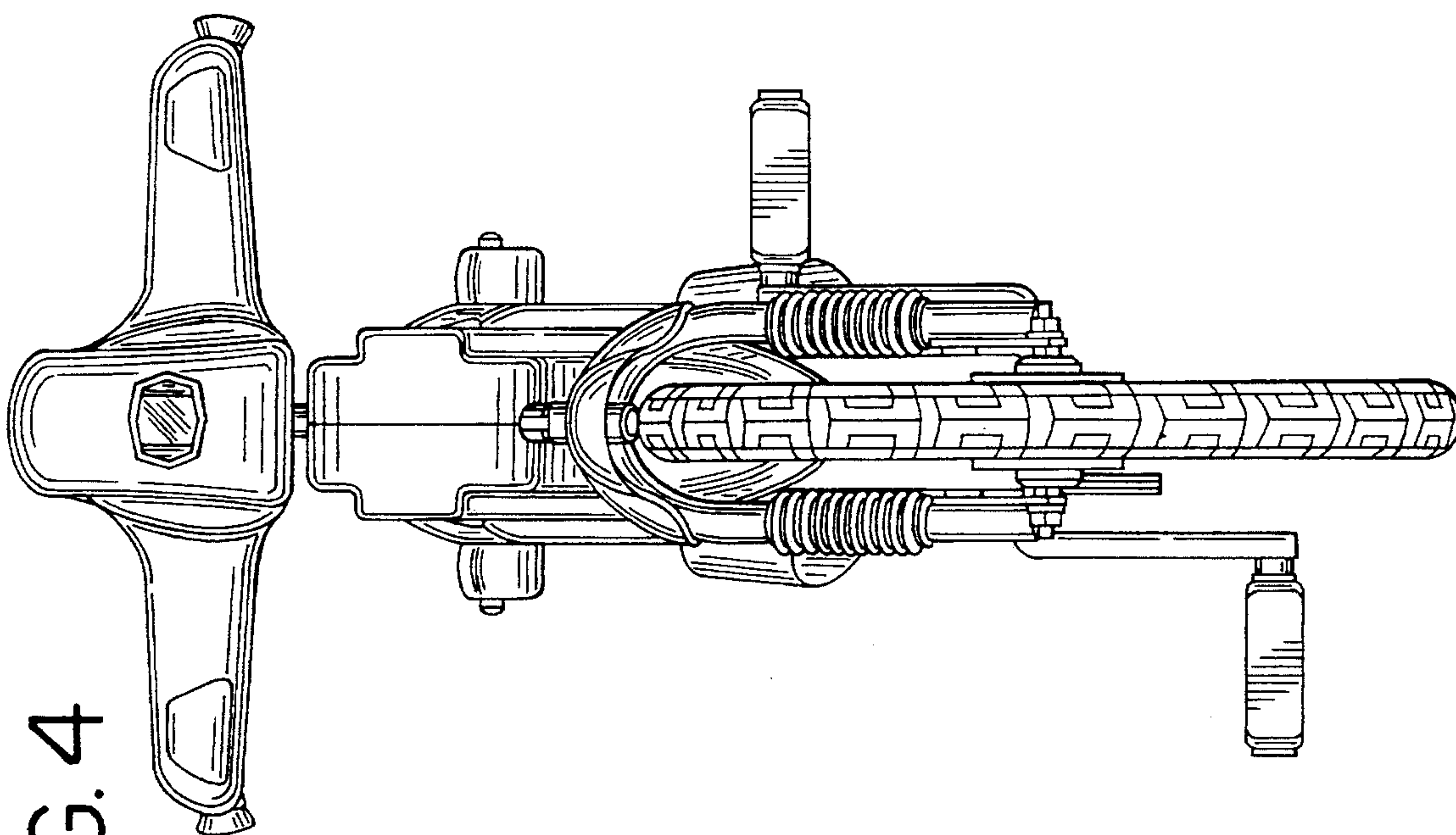
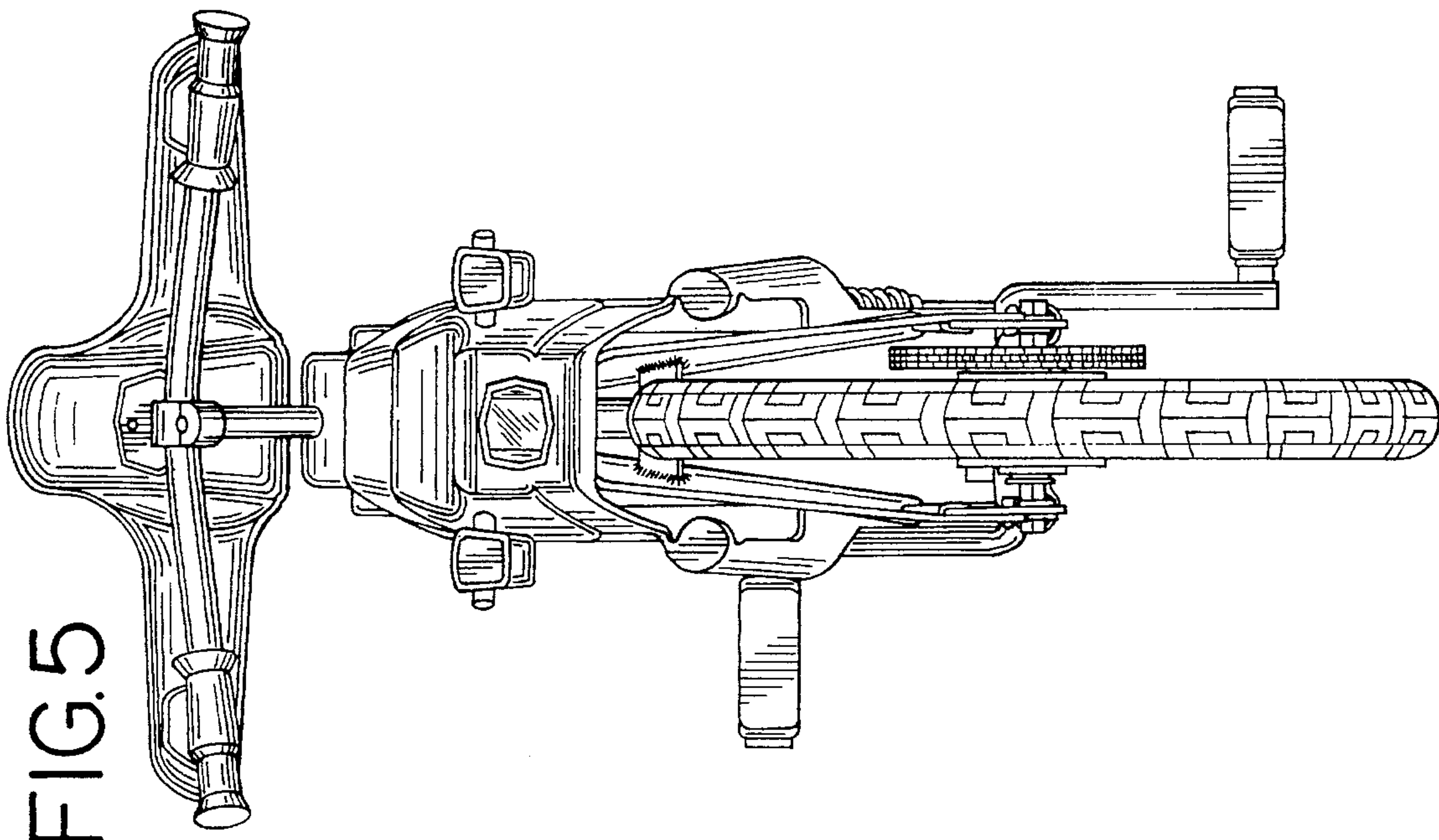

FIG. 5

FIG. 4

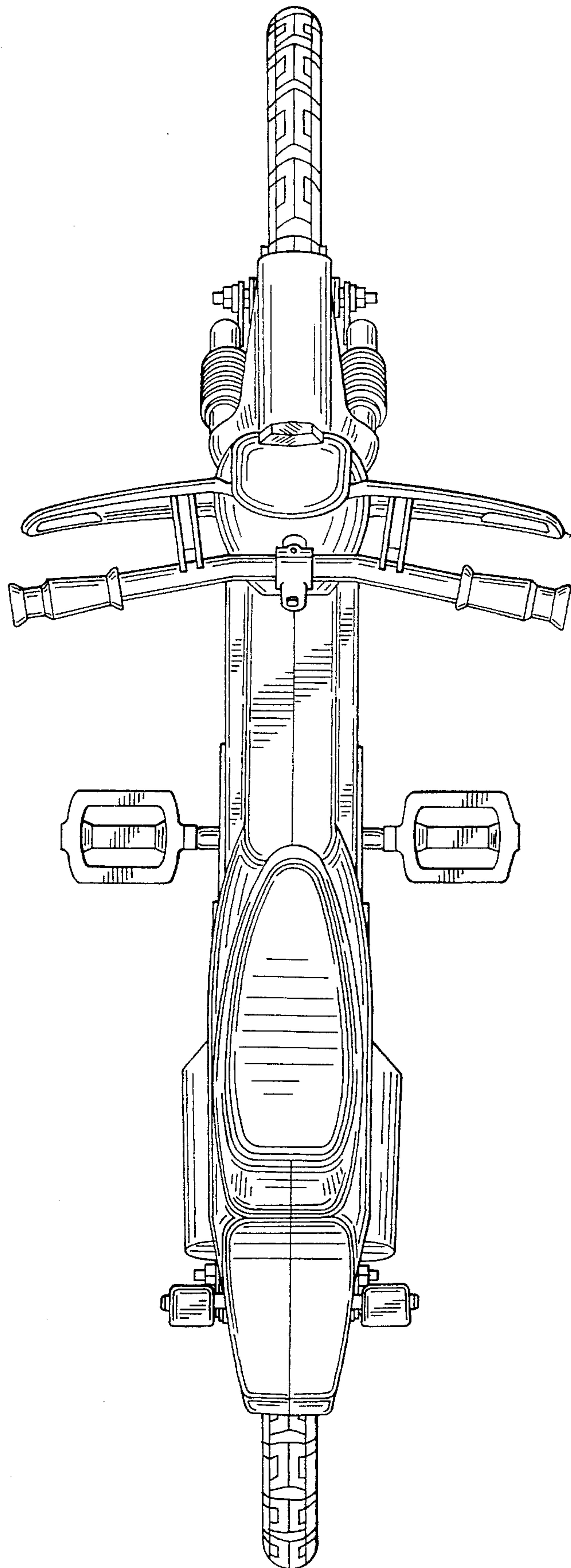

FIG. 6



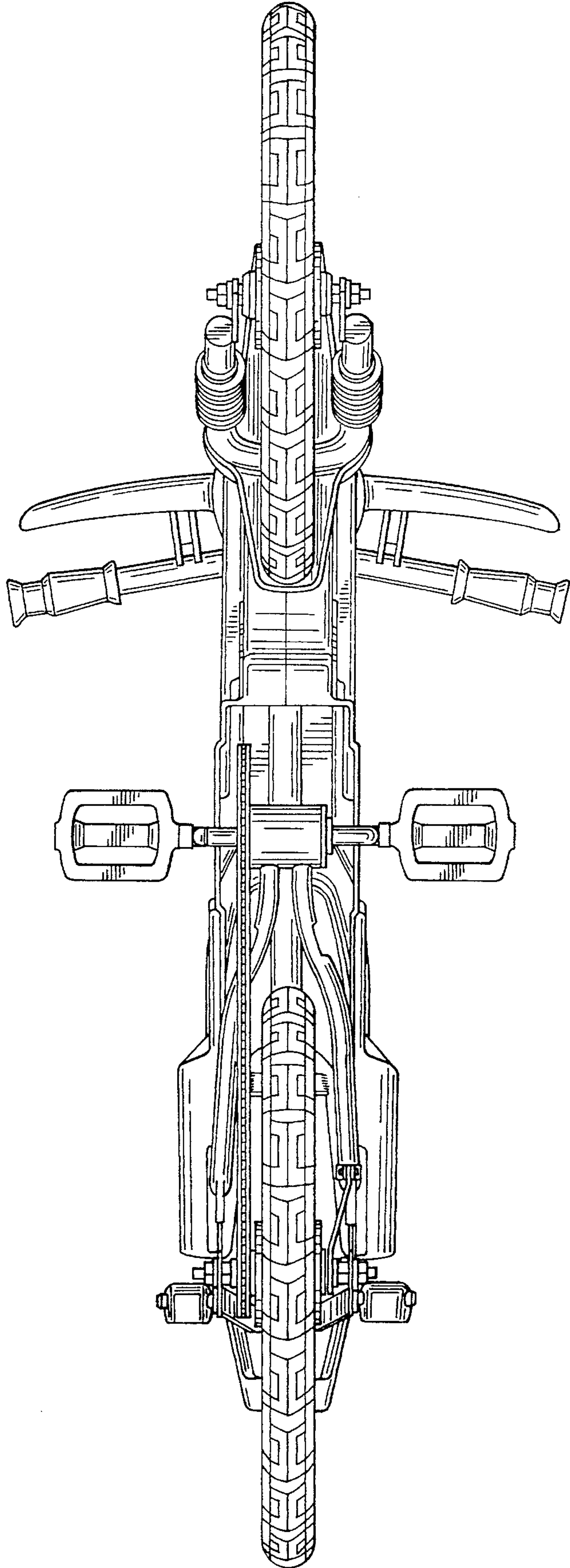

FIG. 7