



US00D376300S

# United States Patent [19]

[11] Patent Number: **Des. 376,300**

**Brown et al.**

[45] Date of Patent: **\*\*Dec. 10, 1996**

[54] **GARDEN STAKE**

D. 319,559 9/1991 Weiss ..... D8/1  
2,996,842 8/1961 Weston ..... 47/45

[76] Inventors: **Lucille F. Brown; Charlotte Brown,**  
both of 6423 76th St., Court W,  
Tacoma, Wash. 98467

*Primary Examiner*—Brian N. Vinson

[\*\*] Term: **14 Years**

[57] **CLAIM**

The ornamental design for a garden stake, as shown and described.

[21] Appl. No.: **43,308**

**DESCRIPTION**

[22] Filed: **Aug. 31, 1995**

[52] U.S. Cl. .... **D8/1**

FIG. 1 is a front elevational view of the garden stake showing our new design;

[58] Field of Search ..... D8/1; 47/39, 41.1,  
47/42, 44-47

FIG. 2 is a rear elevational view thereof;

FIG. 3 is a right view thereof;

FIG. 4 is a left view thereof;

FIG. 5 is a top plan view thereof; and,

FIG. 6 is a bottom plan view thereof.

[56] **References Cited**

**U.S. PATENT DOCUMENTS**

D. 299,307	1/1989	Finnigan	.....	D8/1
D. 303,340	9/1989	Waltel, Jr.	.....	D8/1
D. 310,948	10/1990	Jensen	.....	D8/1

**1 Claim, 3 Drawing Sheets**

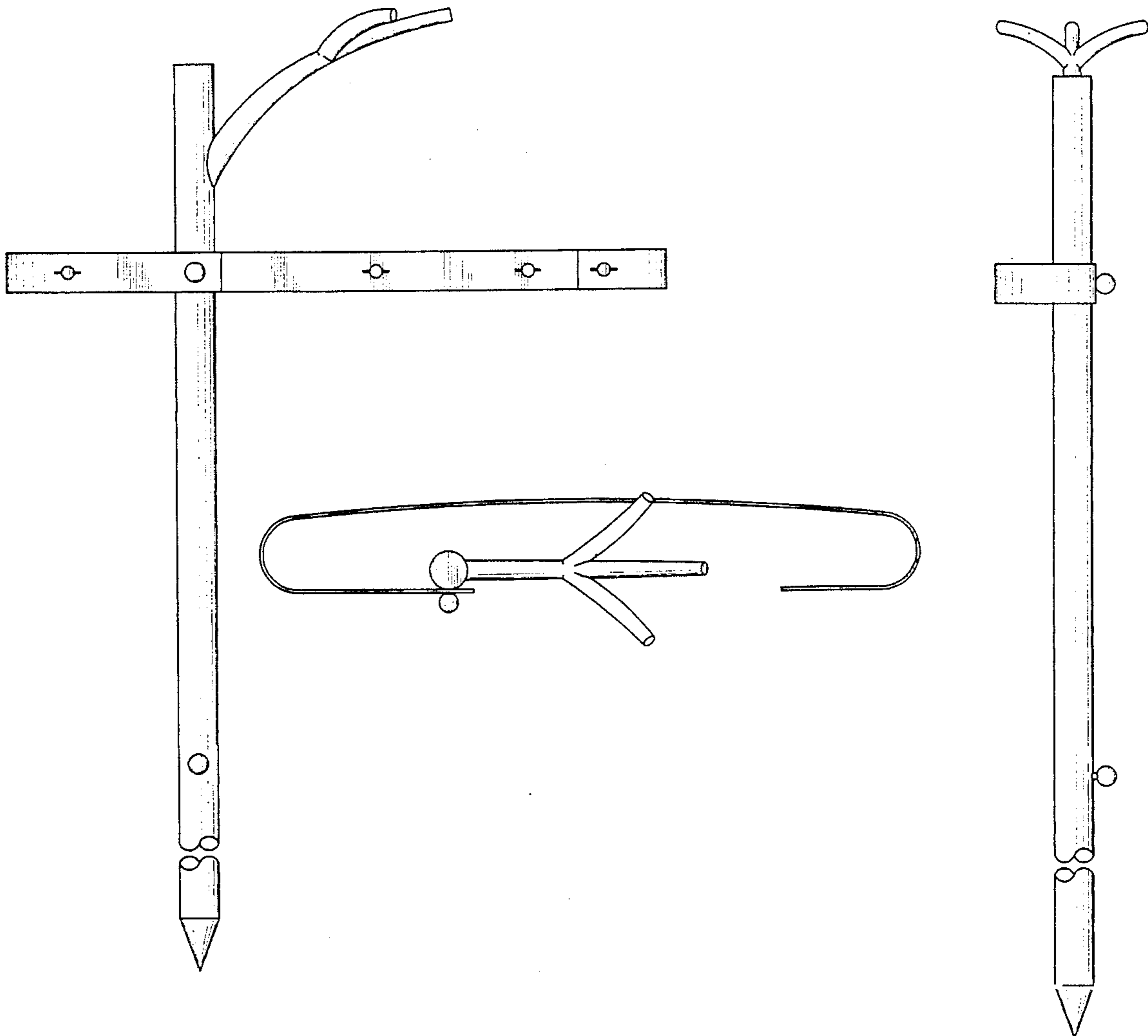

FIG. 1

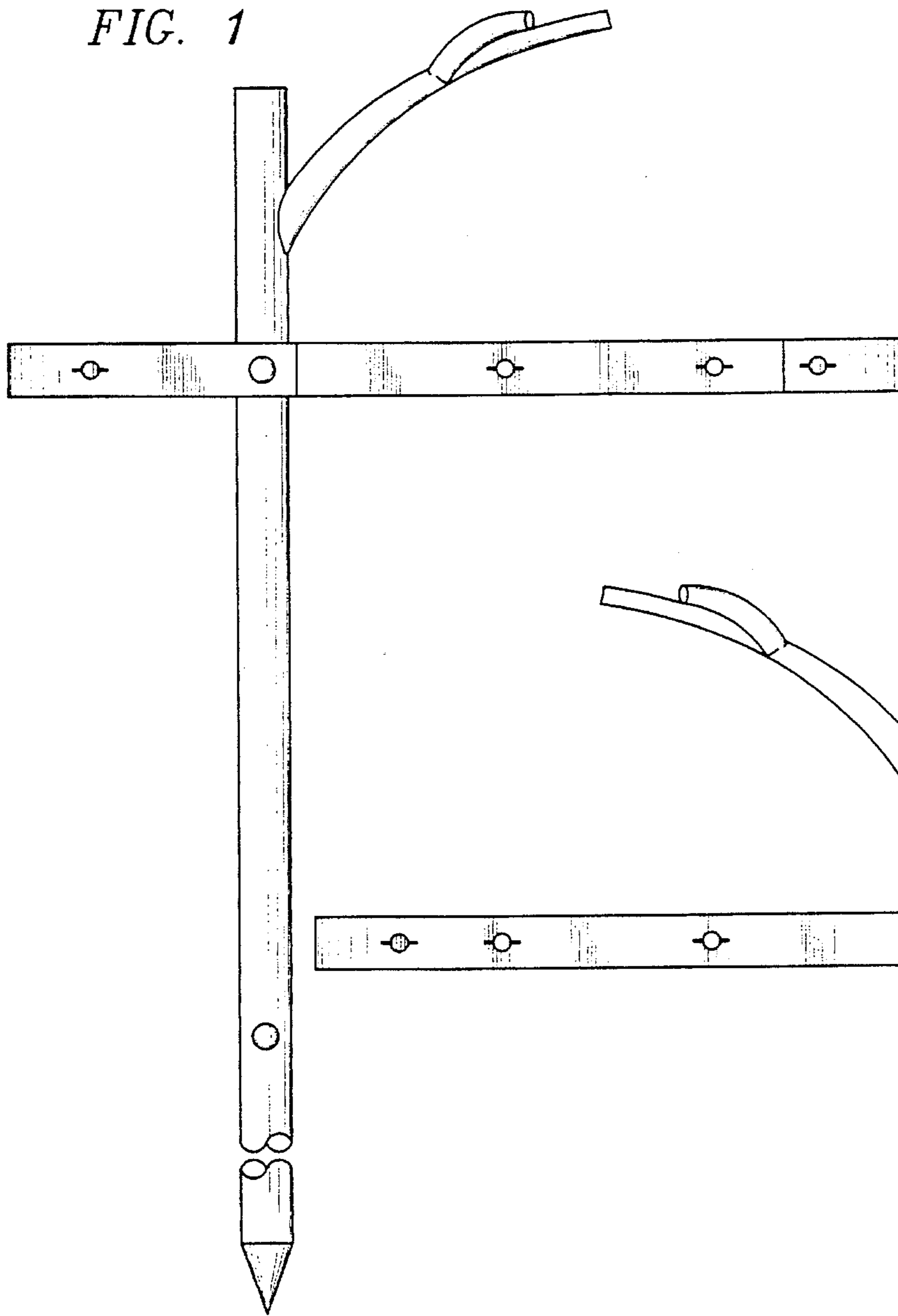

FIG. 2

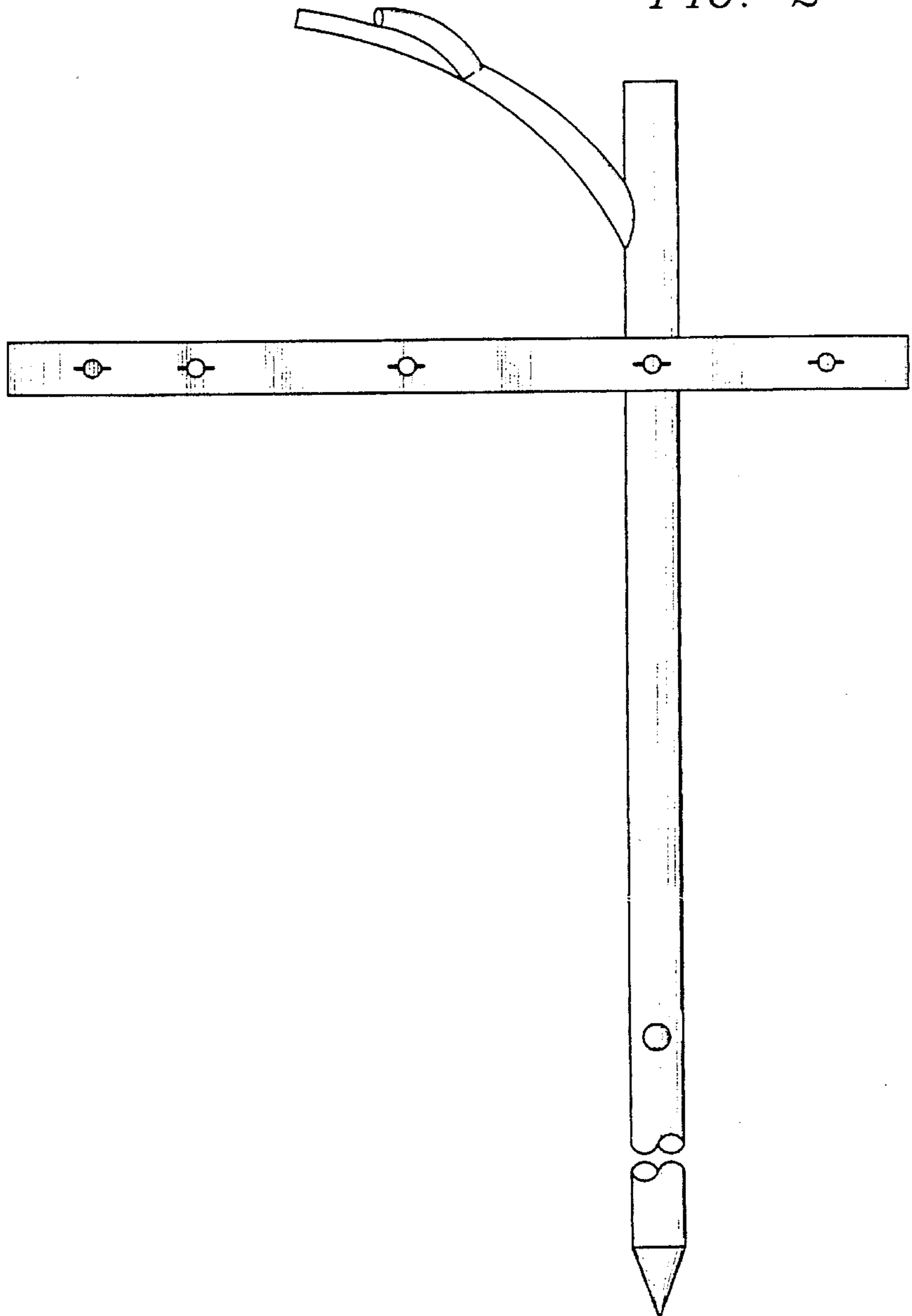

FIG. 3

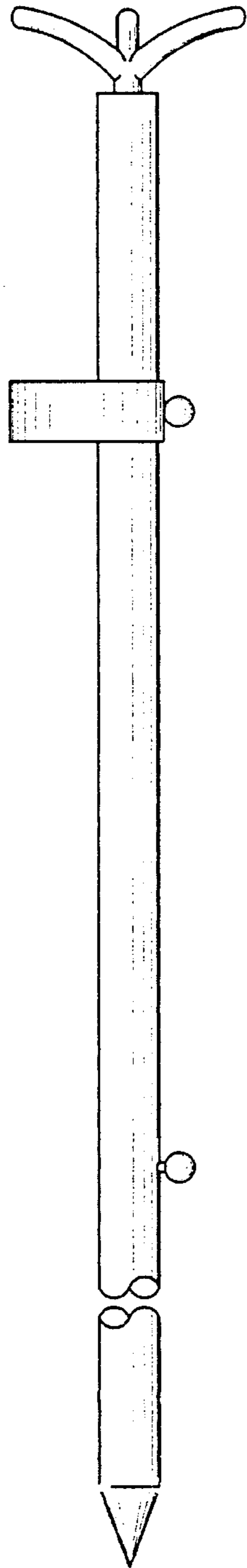

FIG. 4

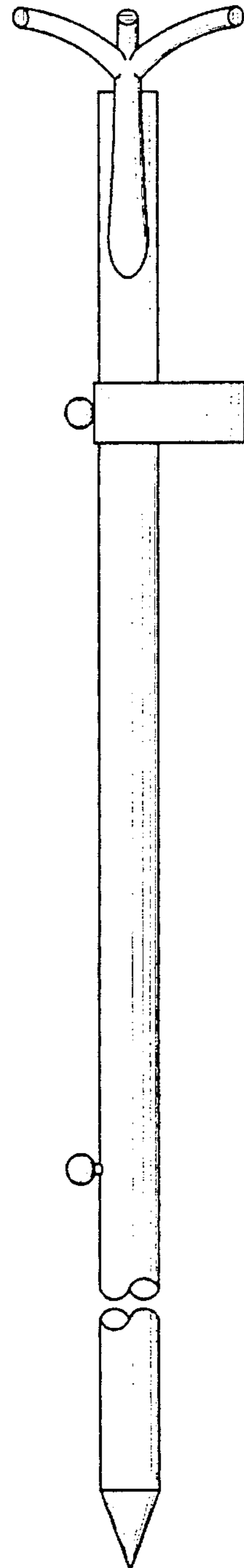

FIG. 5

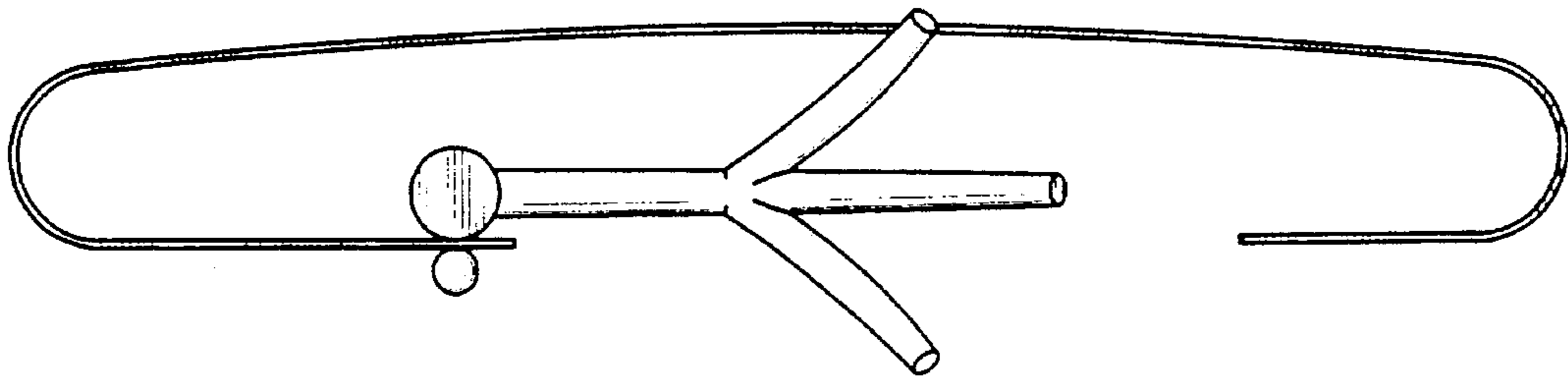

FIG. 6

