



US00D375967S

United States Patent [19]

Michener

[11] Patent Number: **Des. 375,967**

[45] Date of Patent: ****Nov. 26, 1996**

[54] **GREASE FITTING CLEANING TOOL**

[76] Inventor: **Paul B. Michener**, 5565 Lytle Rd.,
Waynesville, Ohio 45068

[**] Term: **14 Years**

[21] Appl. No.: **48,888**

[22] Filed: **Jan. 16, 1996**

[52] U.S. Cl. **D15/150; D15/199**

[58] Field of Search **D15/150, 199;**
D32/1, 30; 148/571; 184/107, 108, 109;
384/624, 625

[56] **References Cited**

U.S. PATENT DOCUMENTS

D. 275,557 9/1984 Souza D10/64

2,315,558 4/1943 Some 148/571

4,183,589 1/1980 Heenan 384/624

5,145,076 9/1992 Murphy et al. 384/624

Primary Examiner—Antoine Duval Davis

Attorney, Agent, or Firm—Jacox, Meckstroth & Jenkins

[57] **CLAIM**

The ornamental design of a grease fitting cleaning tool, as shown and described.

DESCRIPTION

FIG. 1 is a perspective view of a grease fitting cleaning tool showing my new design;

FIG. 2 is a side view thereof;

FIG. 3 is a view of one end thereof; and,

FIG. 4 is a view of the opposite end thereof.

1 Claim, 1 Drawing Sheet

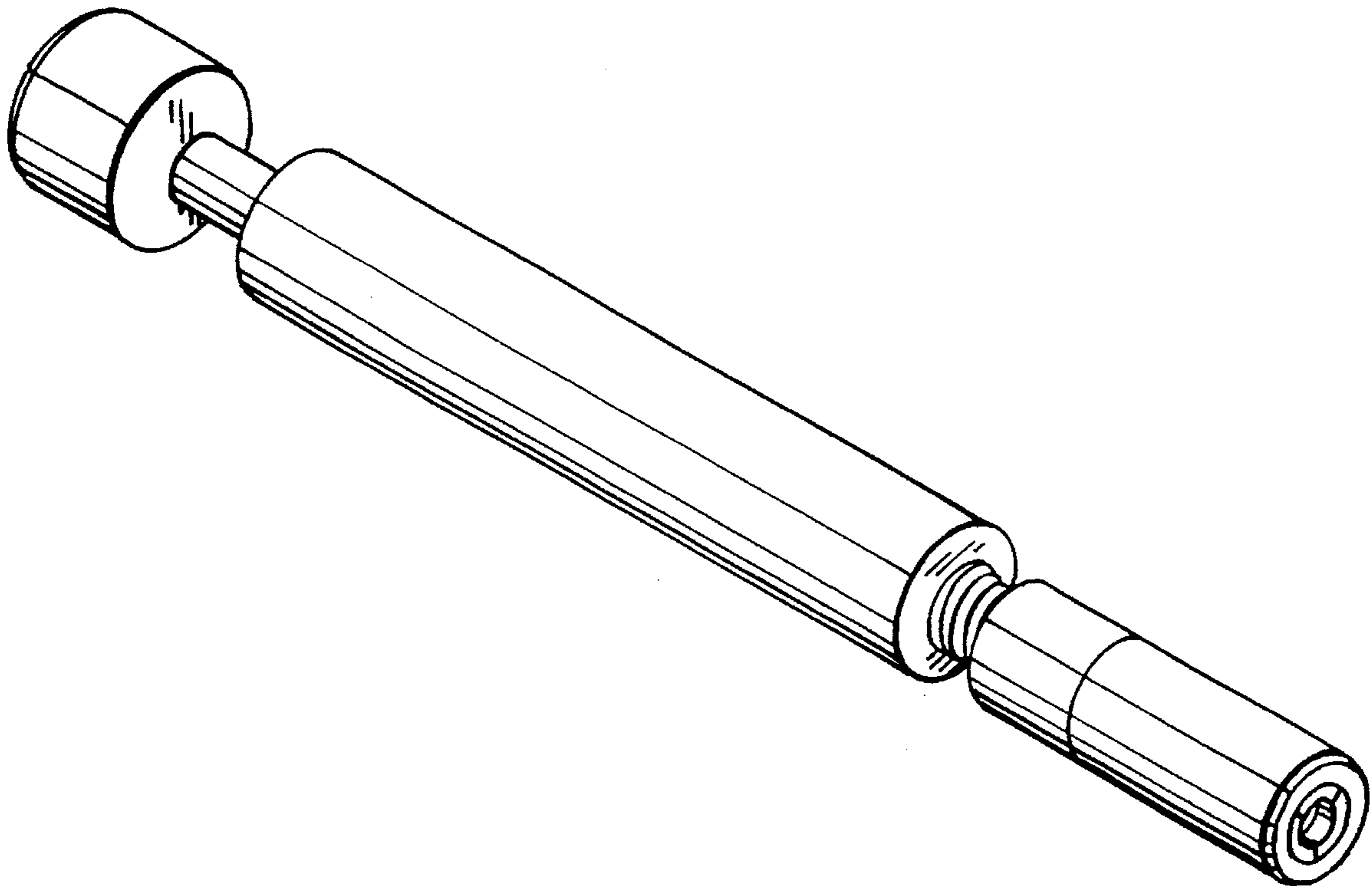

FIG-1

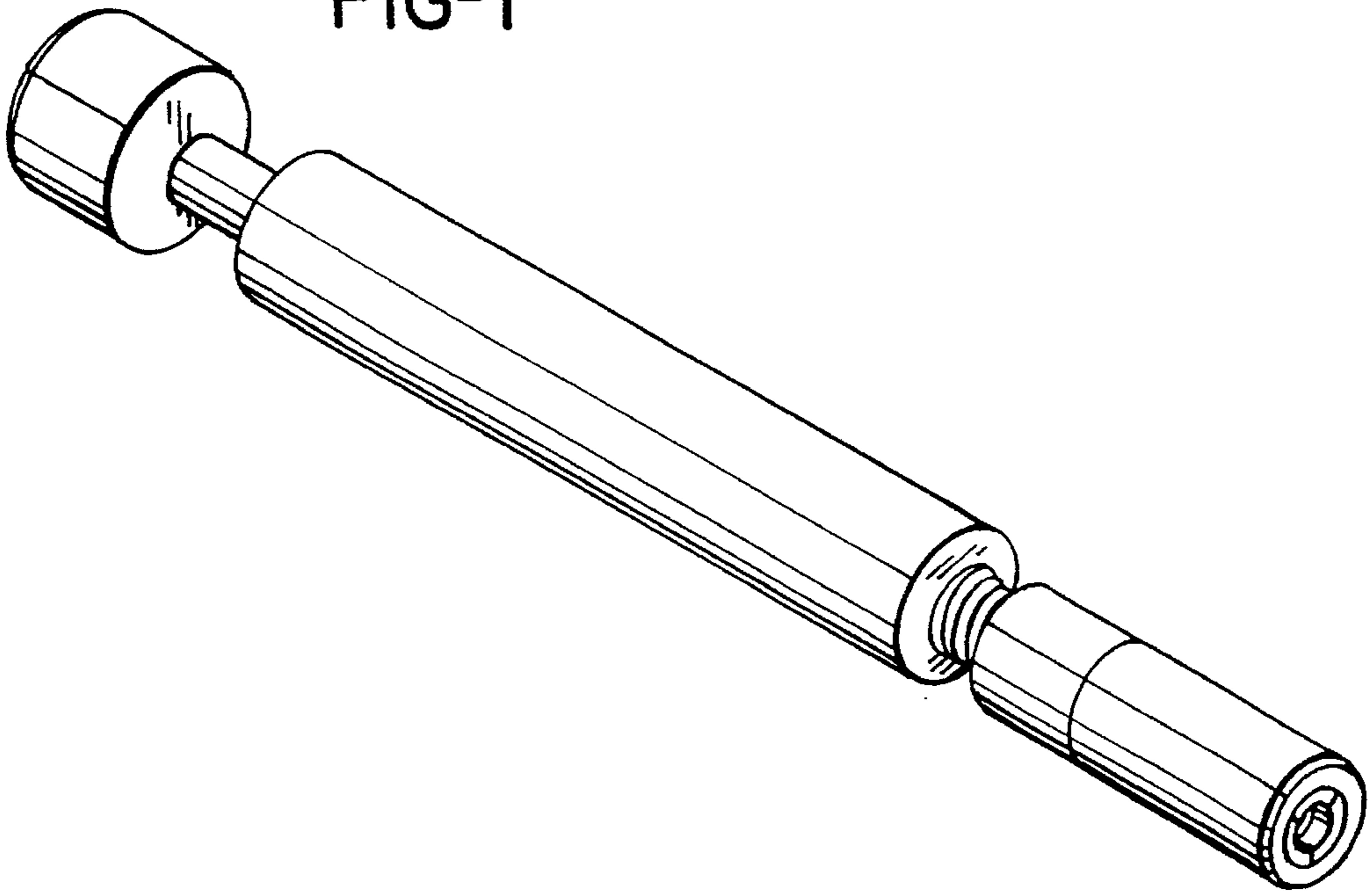

FIG-2

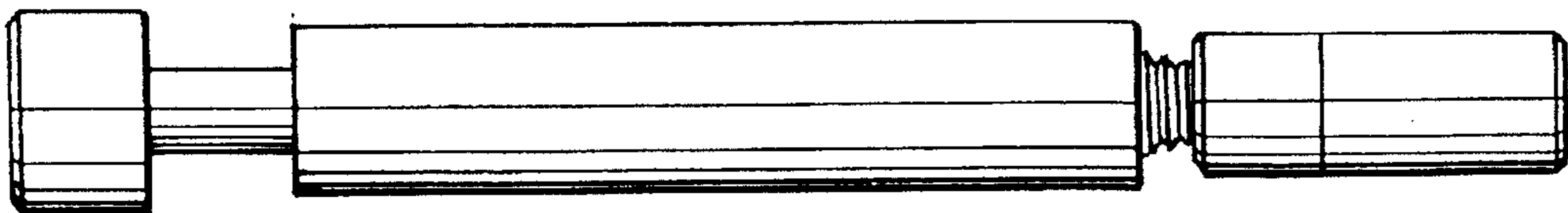

FIG-3



FIG-4

