



US00D375479S

United States Patent [19]

[11] Patent Number: **Des. 375,479**

Lapointe et al.

[45] Date of Patent: ****Nov. 12, 1996**

[54] **JET BOAT**

34221	8/1971	Canada .
42529	8/1977	Canada .
42530	8/1977	Canada .
47076	7/1980	Canada .
57561	11/1986	Canada .
65346	2/1990	Canada .

[75] Inventors: **Denys Lapointe**, Mont Shefford; **Pierre Rondeau**, Bromond, both of Canada; **Shannon Cassell**, Palm Bay, Fla.

[73] Assignee: **Bombardier Inc.**, Montreal, Canada

Primary Examiner—Kay H. Chin
Attorney, Agent, or Firm—Fisher, Christen & Sabol

[**] Term: **14 Years**

[57] **CLAIM**

[21] Appl. No.: **32,127**

The ornamental design for a jet boat, as shown and described.

[22] Filed: **Dec. 8, 1994**

[52] U.S. Cl. **D12/307**; D12/300

DESCRIPTION

[58] Field of Search D12/300-318;
114/57, 270

FIG. 1 is a top plan view of a jet boat, showing our new design;
 FIG. 2 is a rear elevational view thereof;
 FIG. 3 is front elevational view thereof;
 FIG. 4 is a right side elevational view thereof;
 FIG. 5 is a left side elevational view thereof;
 FIG. 6 is a bottom plan view thereof; and,
 FIG. 7 is a perspective view of a jet boat, taken from the top, rear and right side, showing our new design.

[56] **References Cited**

U.S. PATENT DOCUMENTS

D. 330,005	10/1992	Thompson et al.	D12/300
D. 357,223	4/1995	Thompson et al.	D12/313
4,784,074	11/1988	Michalak	114/57

FOREIGN PATENT DOCUMENTS

32785 8/1970 Canada .

1 Claim, 5 Drawing Sheets

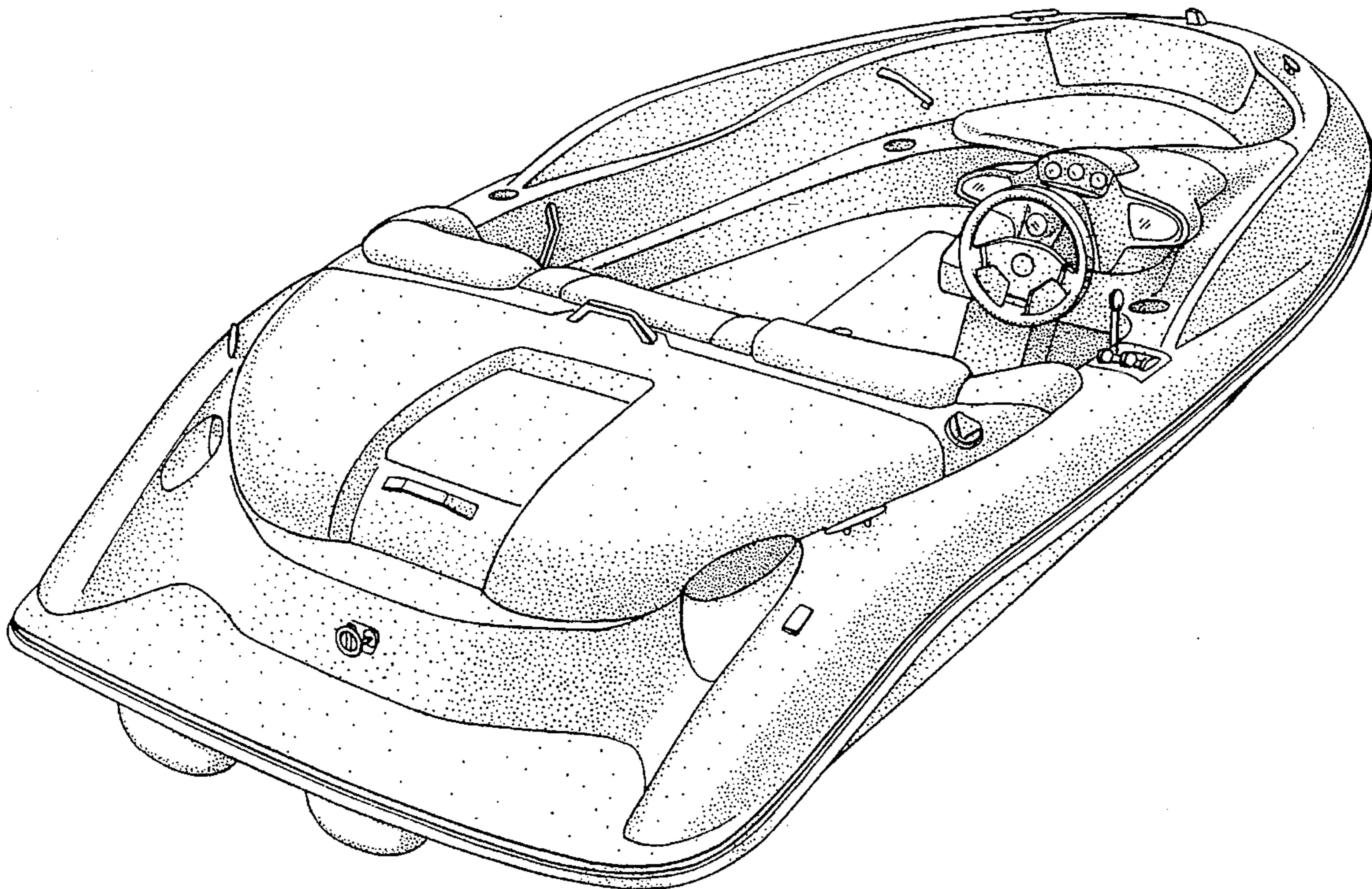

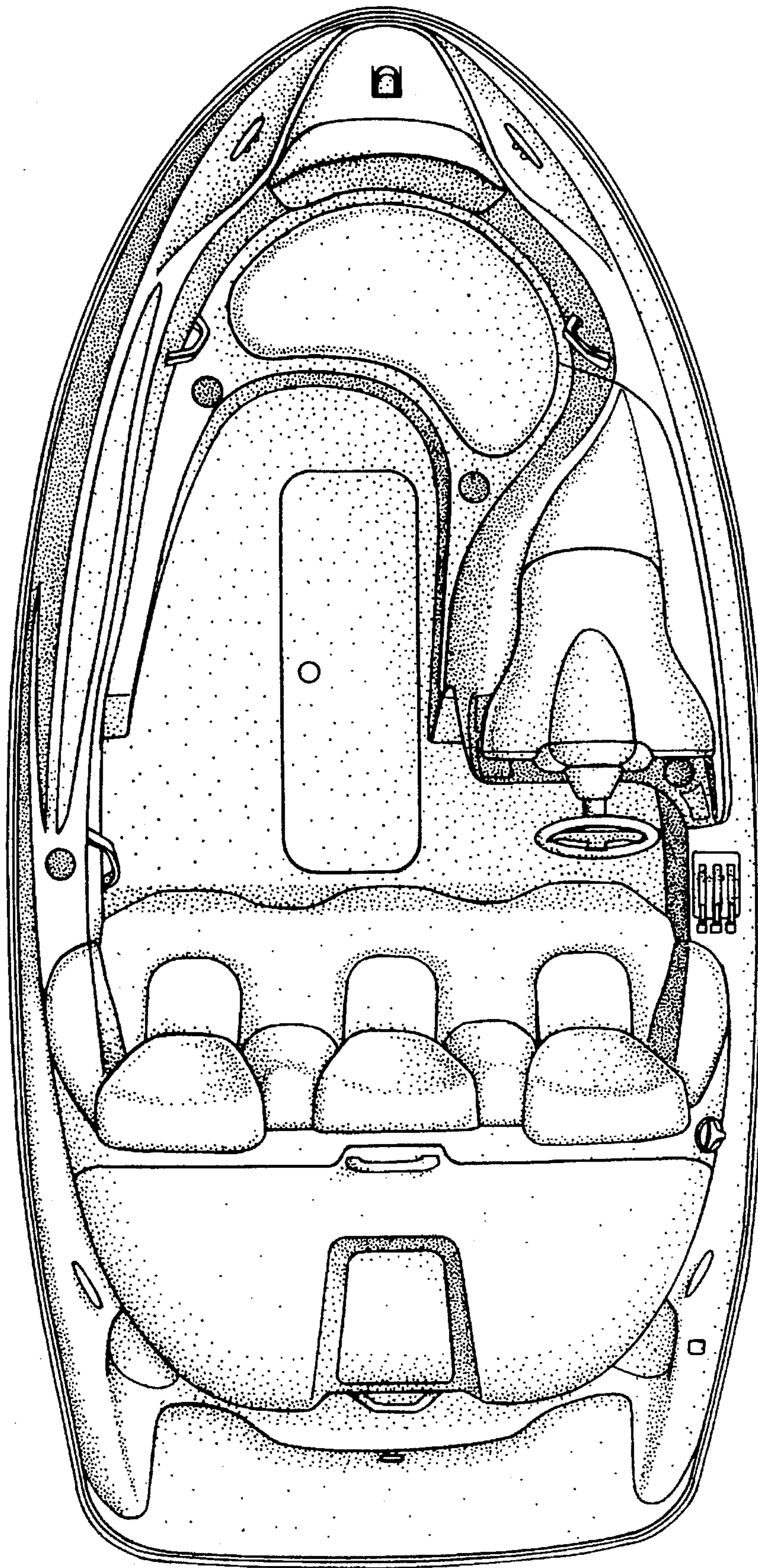

FIG. 1

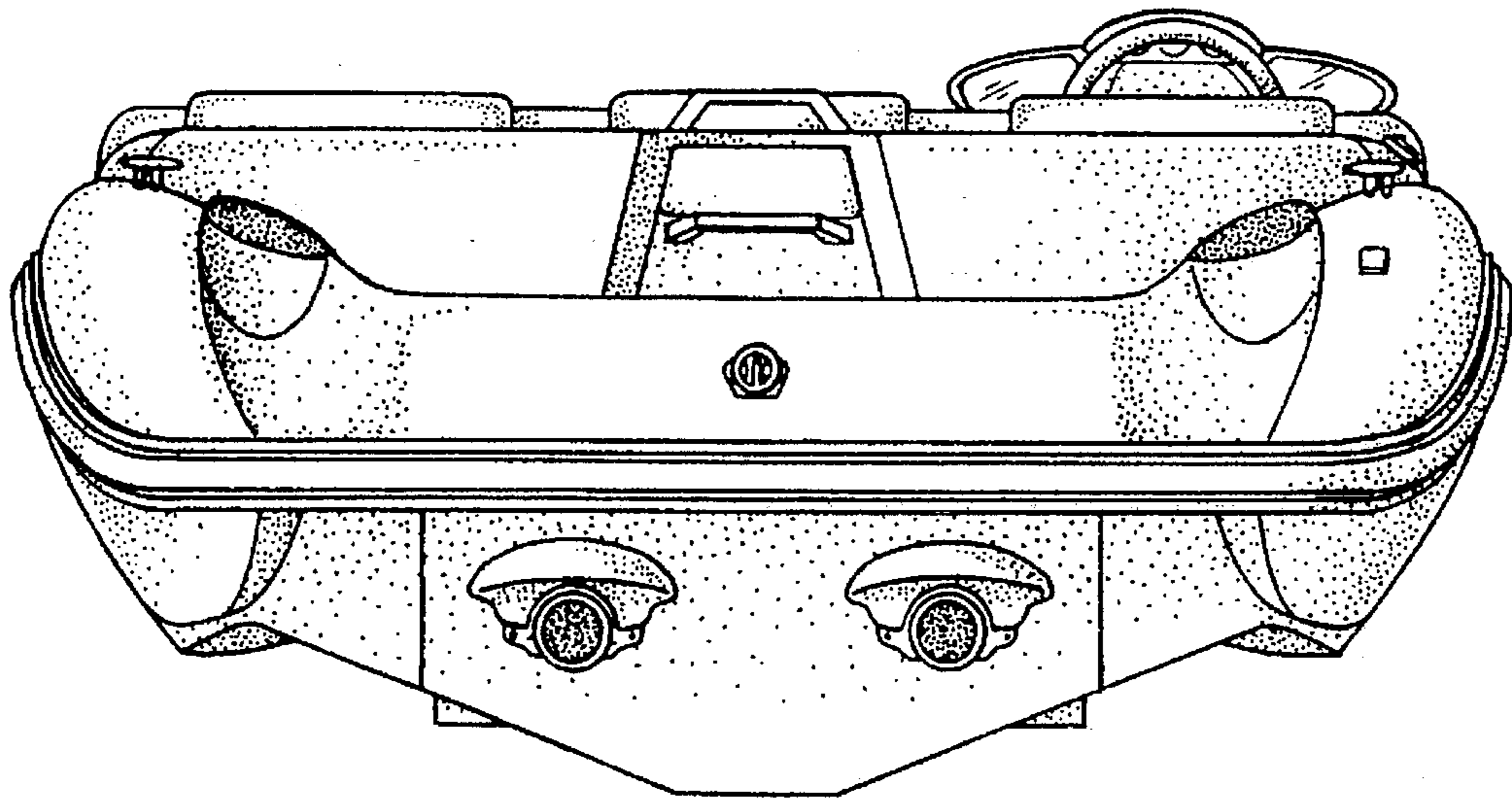

FIG. 2

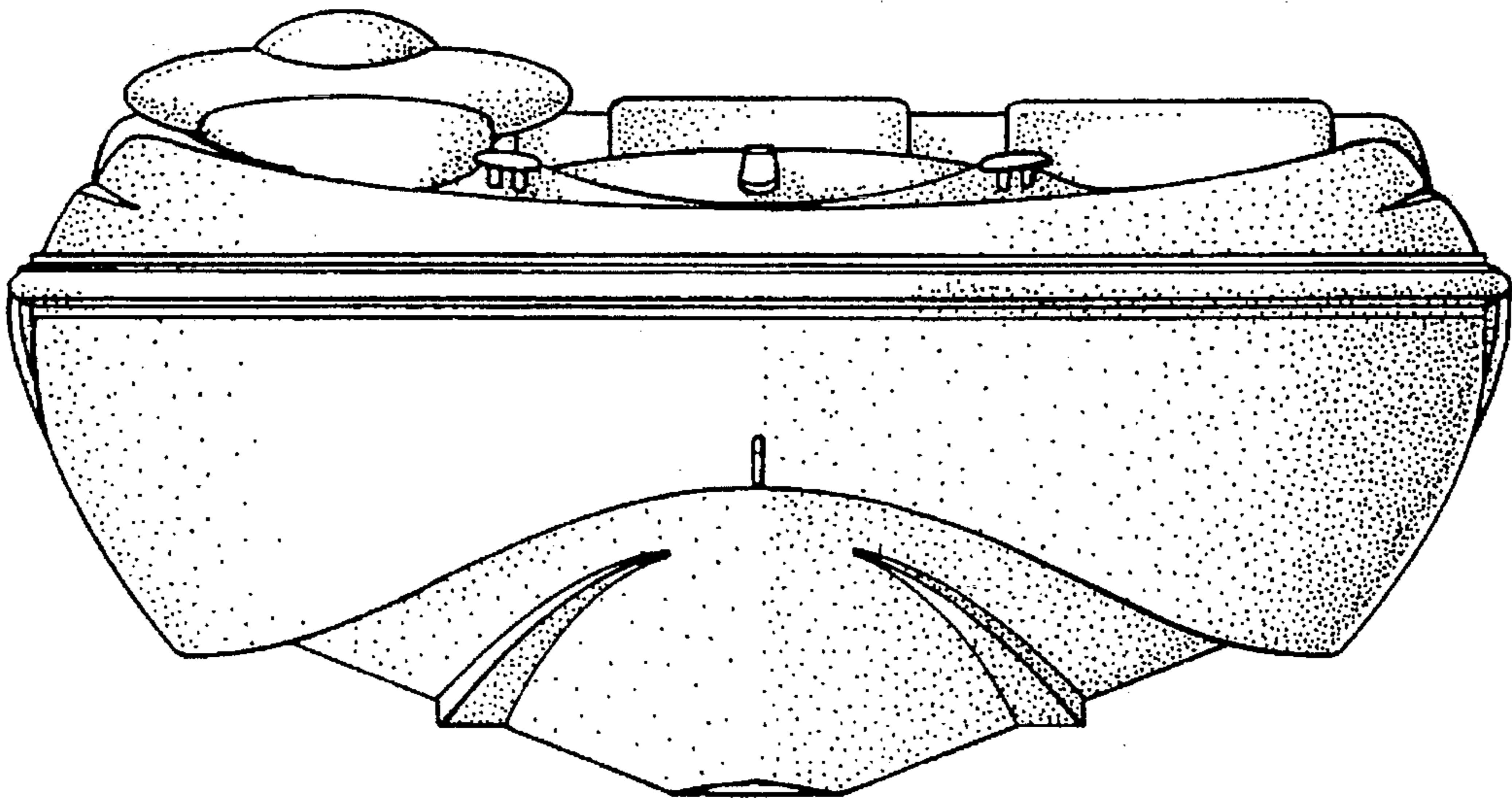

FIG. 3

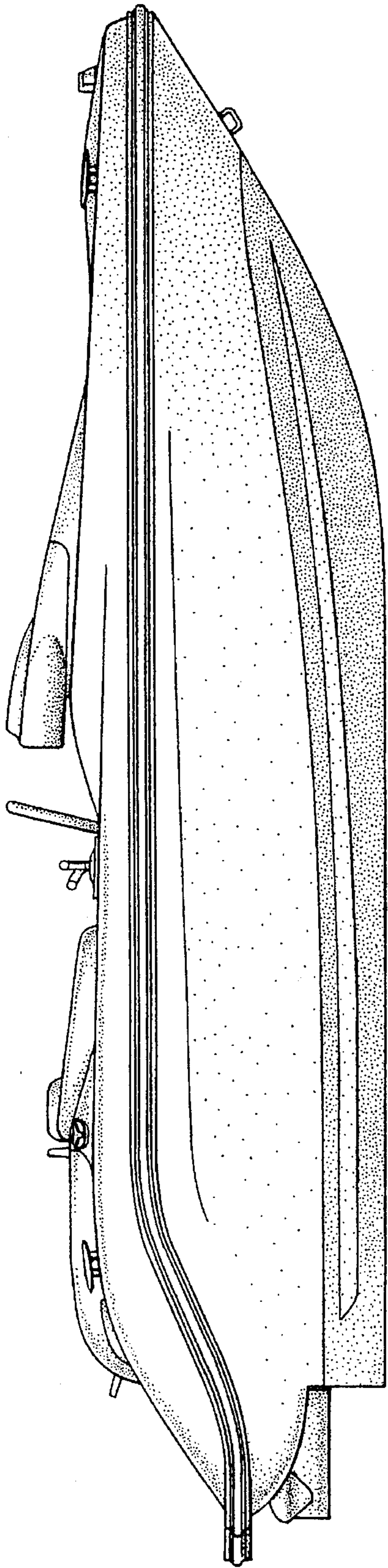

FIG. 4

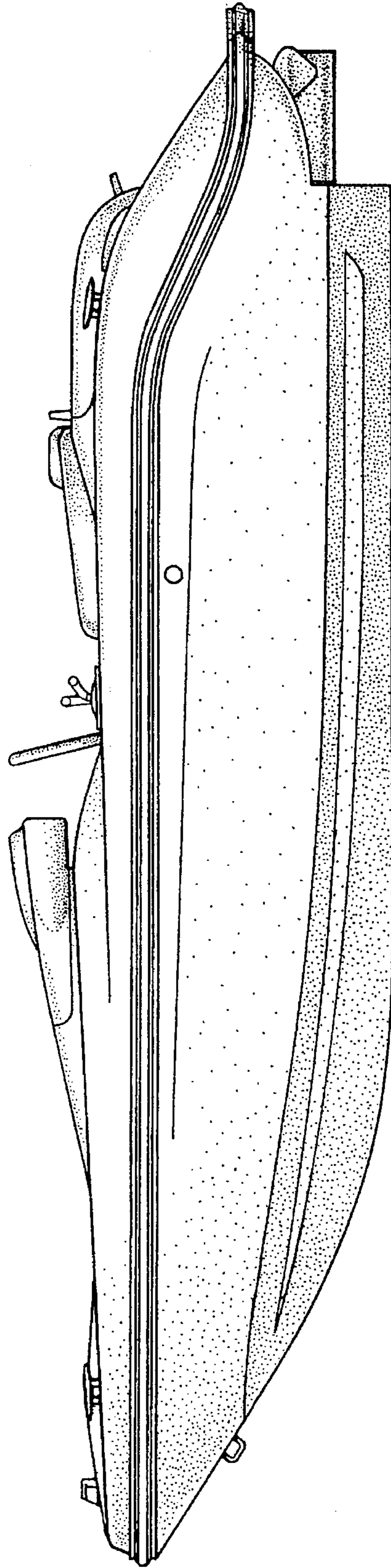

FIG. 5

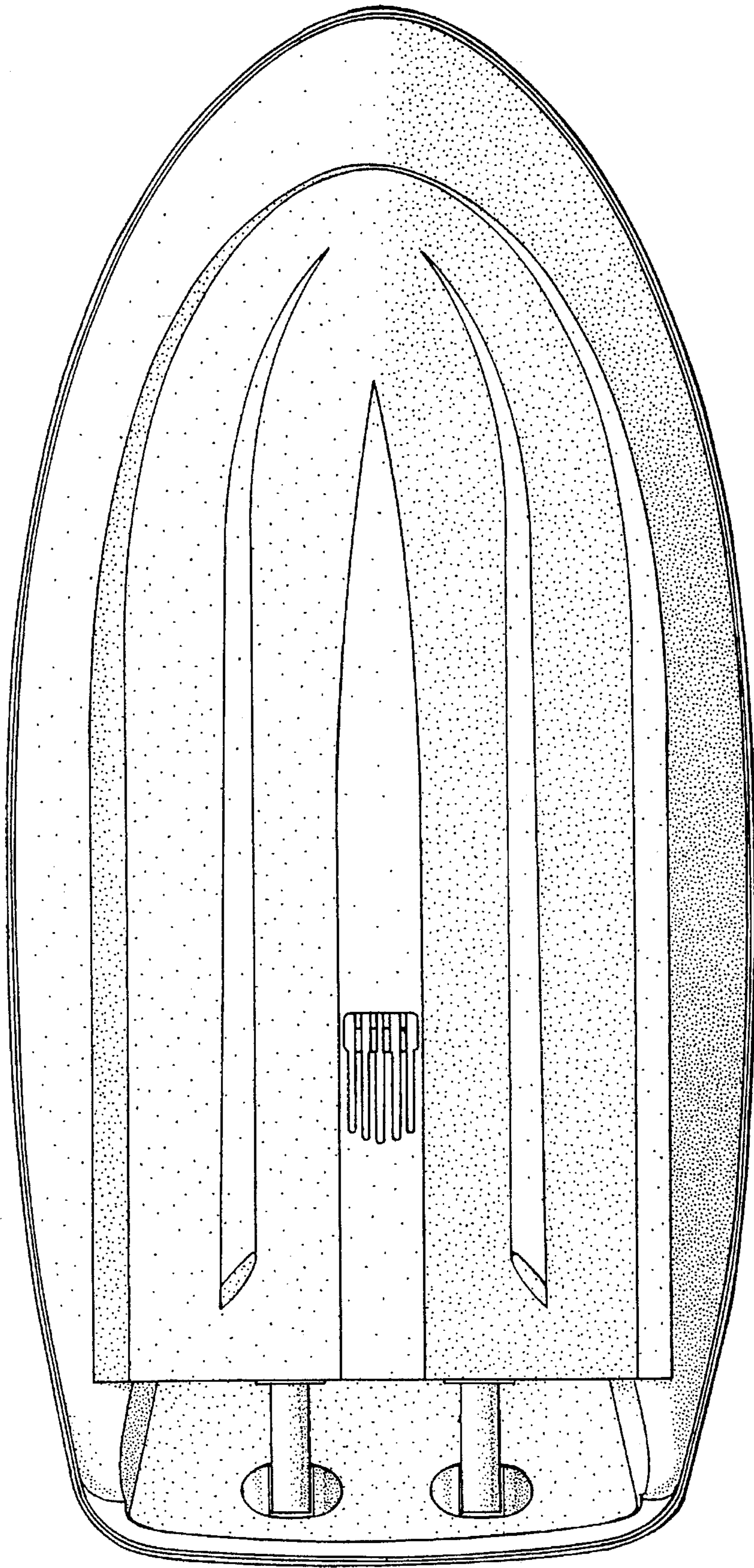

FIG. 6

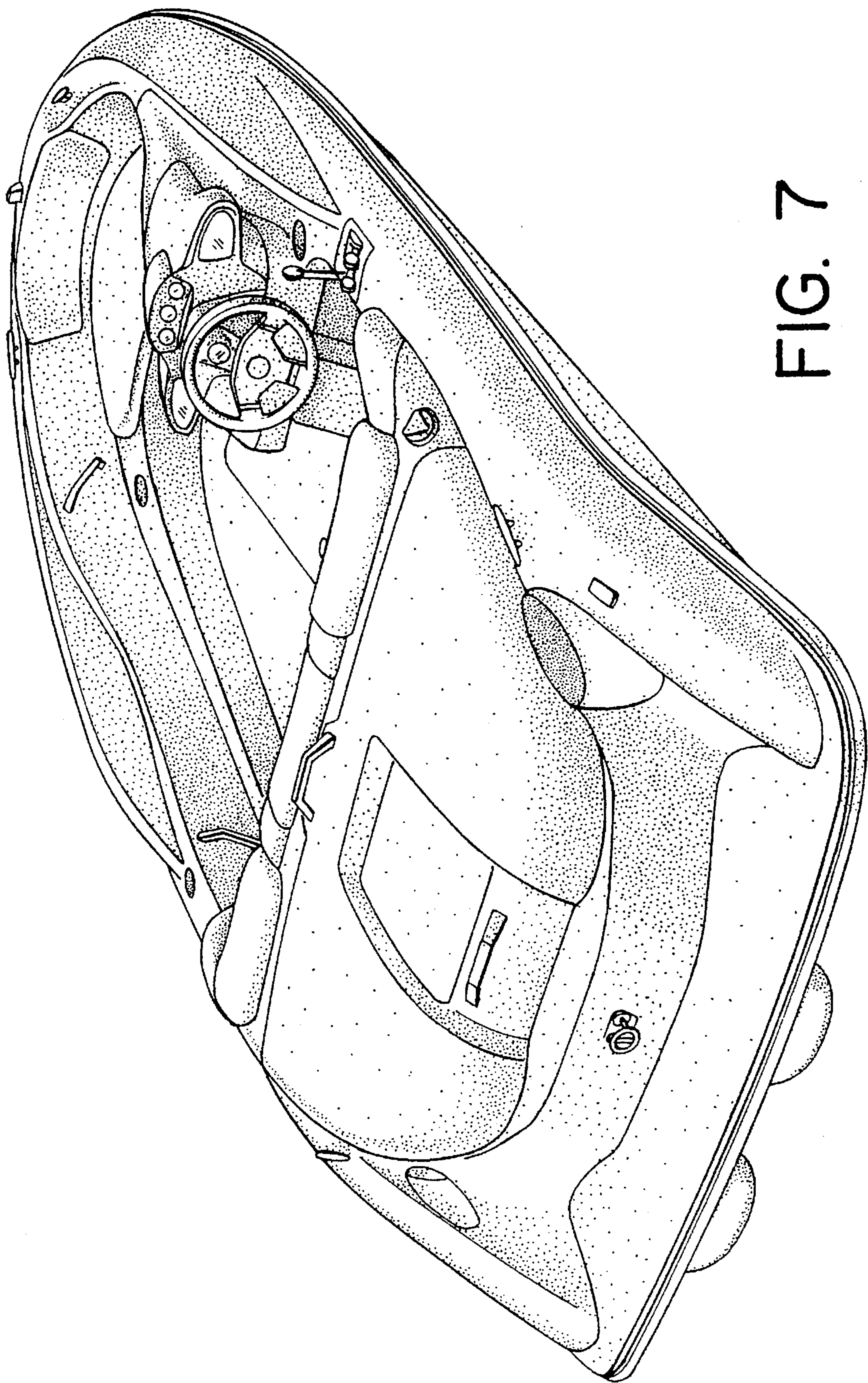

FIG. 7