



US00D375077S

United States Patent [19]

Taylor et al.

[11] Patent Number: **Des. 375,077**

[45] Date of Patent: ****Oct. 29, 1996**

[54] **HELICOPTER**

5,209,430 5/1993 Wilson et al. .

[75] Inventors: **Rodney S. Taylor**, Bedford; **Walter C. Joiner**, Arlington, both of Tex.

OTHER PUBLICATIONS

Canadian Design Patent No. 35187, Mar. 29, 1972 United Aircraft Corporation, East Hartford, Conn. USA.

[73] Assignee: **Bell Helicopter Textron Inc.**, Fort Worth, Tex.

Primary Examiner—Kay H. Chin

[**] Term: **14 Years**

Attorney, Agent, or Firm—Robert A. Felsman; Mark D. Perdue

[21] Appl. No.: **33,952**

[57] CLAIM

[22] Filed: **Jan. 24, 1995**

The ornamental design for a helicopter, as shown and described.

[52] U.S. Cl. **D12/327**

[58] Field of Search D12/319, 326, D12/327, 328, 329; 244/17.11, 17.19, 17.21

DESCRIPTION

[56] References Cited

U.S. PATENT DOCUMENTS

- D. 239,710 4/1976 Garrison .
- D. 242,338 11/1976 Gilday .
- D. 278,227 4/1985 Johnston, Jr. .
- D. 332,078 12/1992 Shallene .
- D. 357,894 5/1995 Arnold et al. D12/328
- D. 363,054 10/1995 Taylor et al. D12/326
- 4,809,930 3/1989 Ballerio et al. .
- 5,093,677 3/1992 McMahon .

FIG. 1 is a right side elevational view of the helicopter showing our new design;
 FIG. 2 is a left side elevational view thereof;
 FIG. 3 is a front elevational view thereof;
 FIG. 4 is a rear elevational view thereof;
 FIG. 5 is a top plan view thereof; and,
 FIG. 6 is a bottom plan view thereof.
 Portions of the rotor blades in FIGS. 5 and 6 are shown broken away for convenience of illustration.

1 Claim, 3 Drawing Sheets

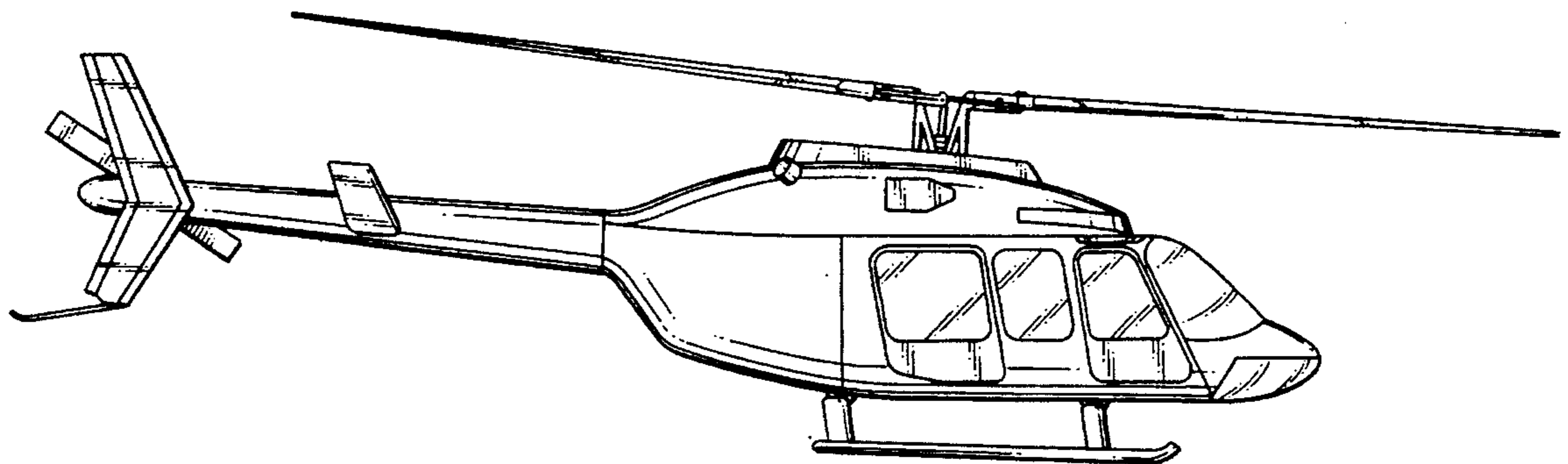

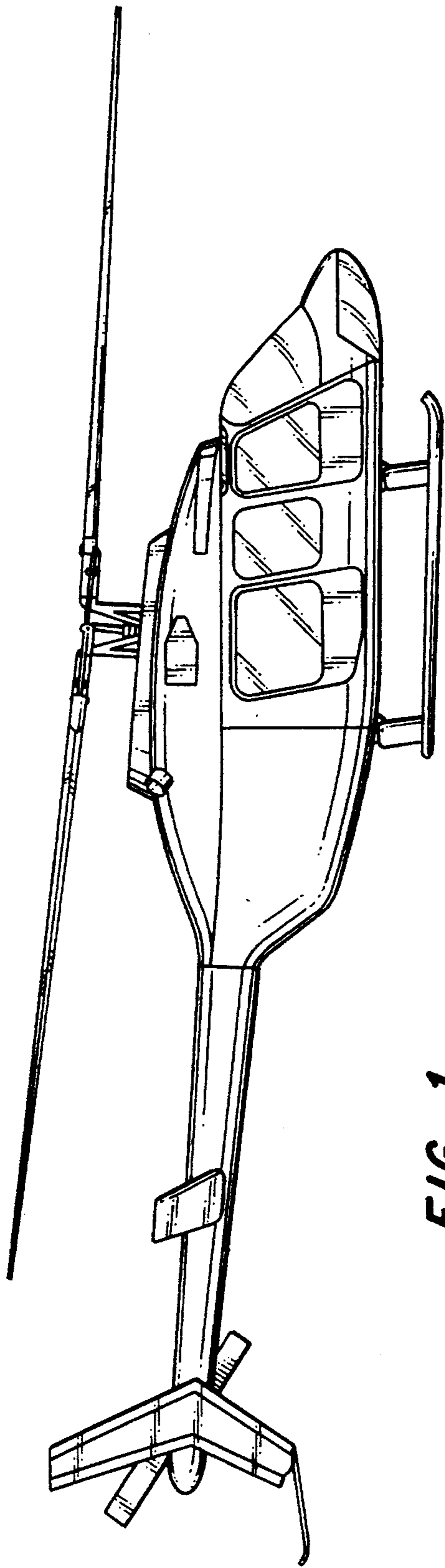

FIG. 1

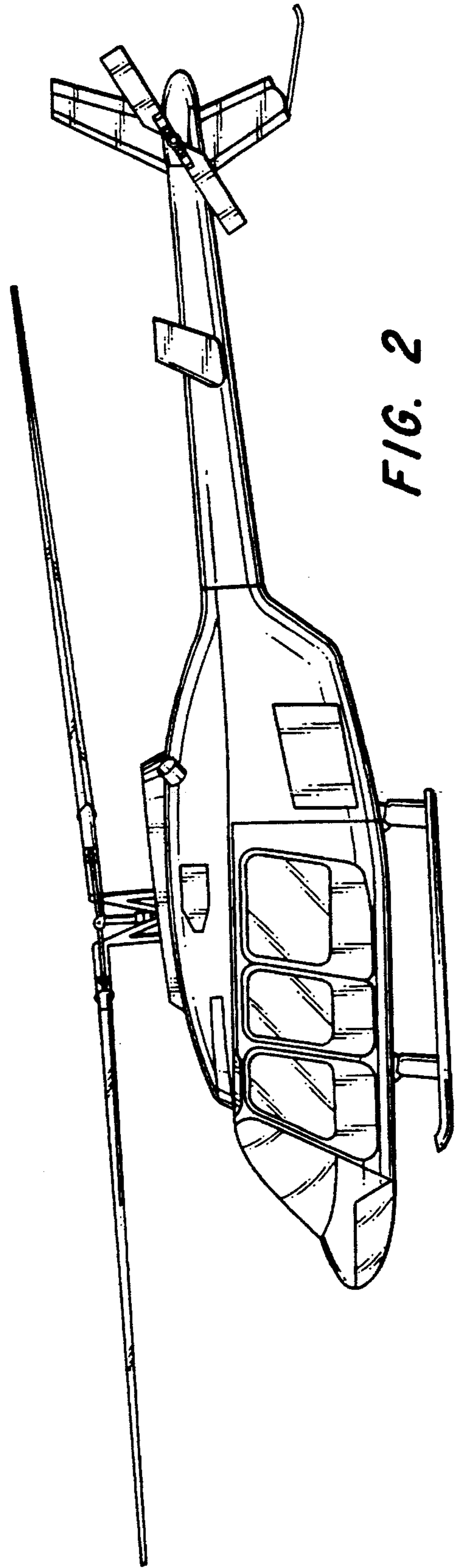

FIG. 2



FIG. 3

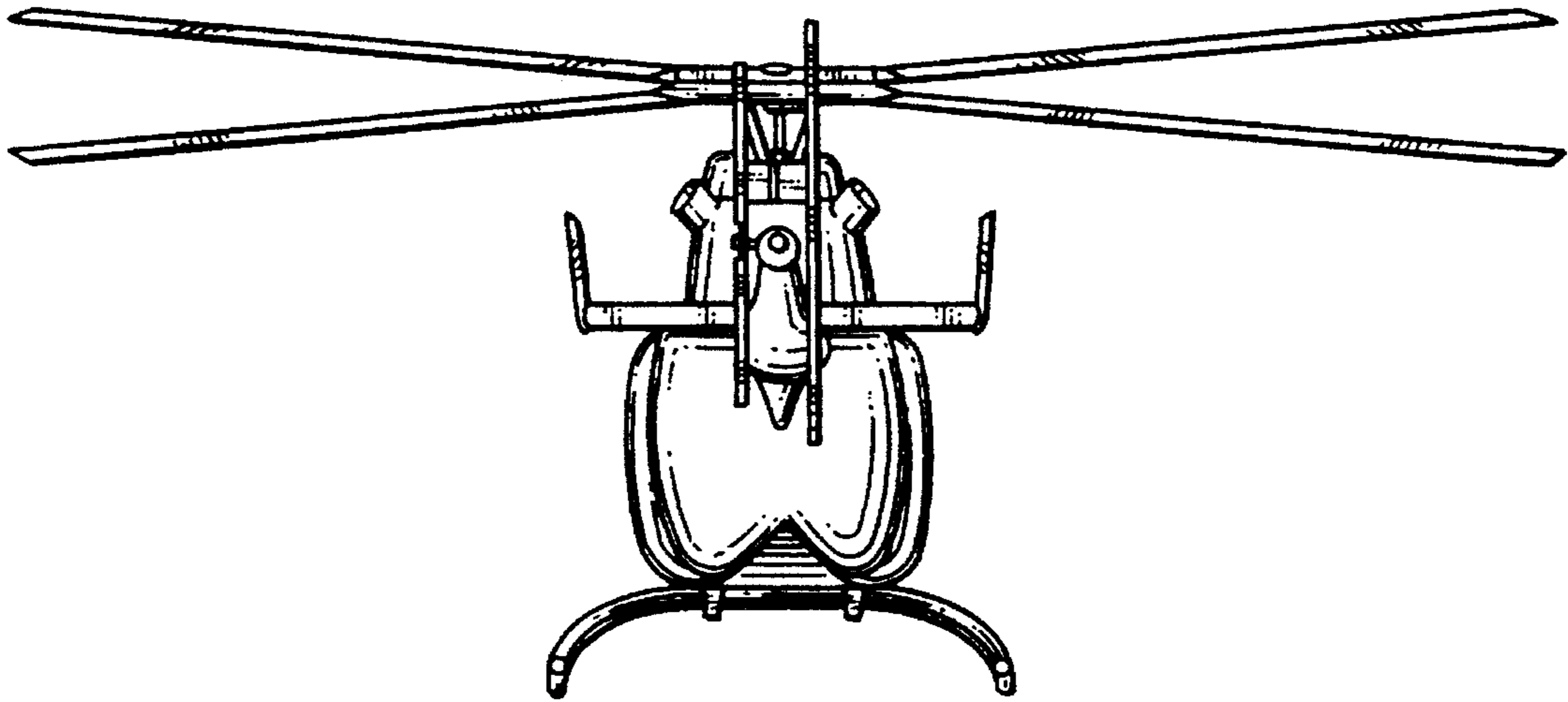

FIG. 4

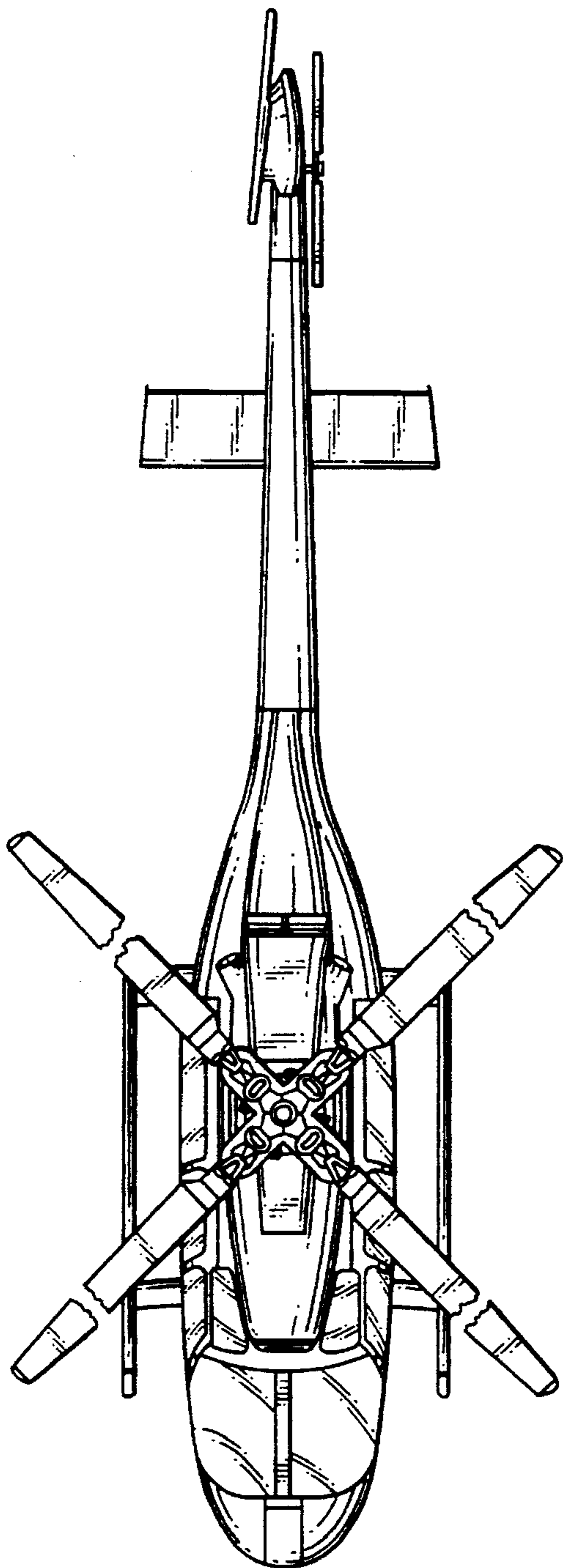

FIG. 5

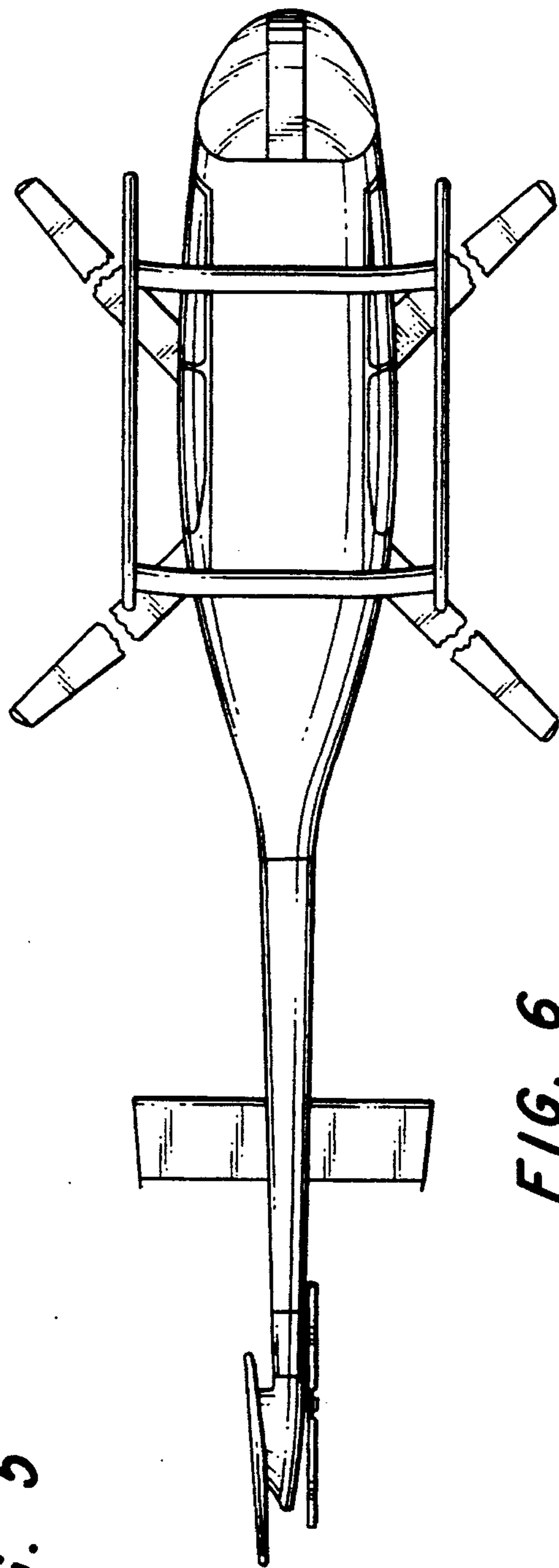

FIG. 6