



US00D375068S

United States Patent [19]

[11] Patent Number: **Des. 375,068**

Lund

[45] Date of Patent: ****Oct. 29, 1996**

[54] **SIDE WINDOW COVER FOR VEHICLE**

[75] Inventor: **David M. Lund**, Andover, Minn.

[73] Assignee: **Lund Industries, Inc.**, Minneapolis, Minn.

[**] Term: **14 Years**

[21] Appl. No.: **29,831**

[22] Filed: **Oct. 21, 1994**

[52] U.S. Cl. **D12/183; D12/190**

[58] Field of Search **D12/190, 183; 49/50, 501; 160/105, 354, 371, 370.2 A, 370.2 R; 296/180.1, 96.11, 95.1, 96.16, 97.1, 152; 454/128, 134**

[56] **References Cited**

U.S. PATENT DOCUMENTS

D. 248,941	8/1978	Carlsson et al. .	
D. 287,482	12/1986	Unzicker	D12/183
D. 355,880	2/1995	Roberts	D12/183
3,083,630	4/1963	Thaxton	160/105
4,023,309	5/1977	Backward	296/152 X

OTHER PUBLICATIONS

"J. C. Whitney Catalog", Mar. 1992, p. 66, Custom-Fit Side Window Louvers.

"Trader's Spring '95 Accessories Catalog No. 7", first page, last page and p. 57.

Primary Examiner—James M. Gandy

Assistant Examiner—Cathron B. Matta

Attorney, Agent, or Firm—Merchant, Gould, Smith, Edell, Welter & Schmidt, P.A.

[57] **CLAIM**

The ornamental design for a side window cover for vehicle, as shown and described.

DESCRIPTION

FIG. 1 is a view in perspective of a side window cover for vehicle attached to the passenger side of a pickup truck, wherein the pickup truck is shown in broken lines for illustrative purposes only and is not part of the claimed design;

FIG. 2 is an enlarged front view thereof;

FIG. 3 is an enlarged rear view thereof;

FIG. 4 is an enlarged left side view thereof;

FIG. 5 is an enlarged right side view thereof;

FIG. 6 is an enlarged top view thereof;

FIG. 7 is an enlarged bottom view thereof;

FIG. 8 is a view in perspective of an alternative embodiment of a side window cover for vehicle attached to the passenger side of a pickup truck, wherein the side window cover for vehicle has a cut-away portion and the pickup truck is shown in broken lines for illustrative purposes only and is not part of the claimed design;

FIG. 9 is an enlarged front view of the alternative embodiment;

FIG. 10 is an enlarged rear view of the alternative embodiment;

FIG. 11 is an enlarged left side view of the alternative embodiment;

FIG. 12 is an enlarged right side view of the alternative embodiment;

FIG. 13 is an enlarged top view of the alternative embodiment; and,

FIG. 14 is an enlarged bottom view of the alternative embodiment.

1 Claim, 6 Drawing Sheets

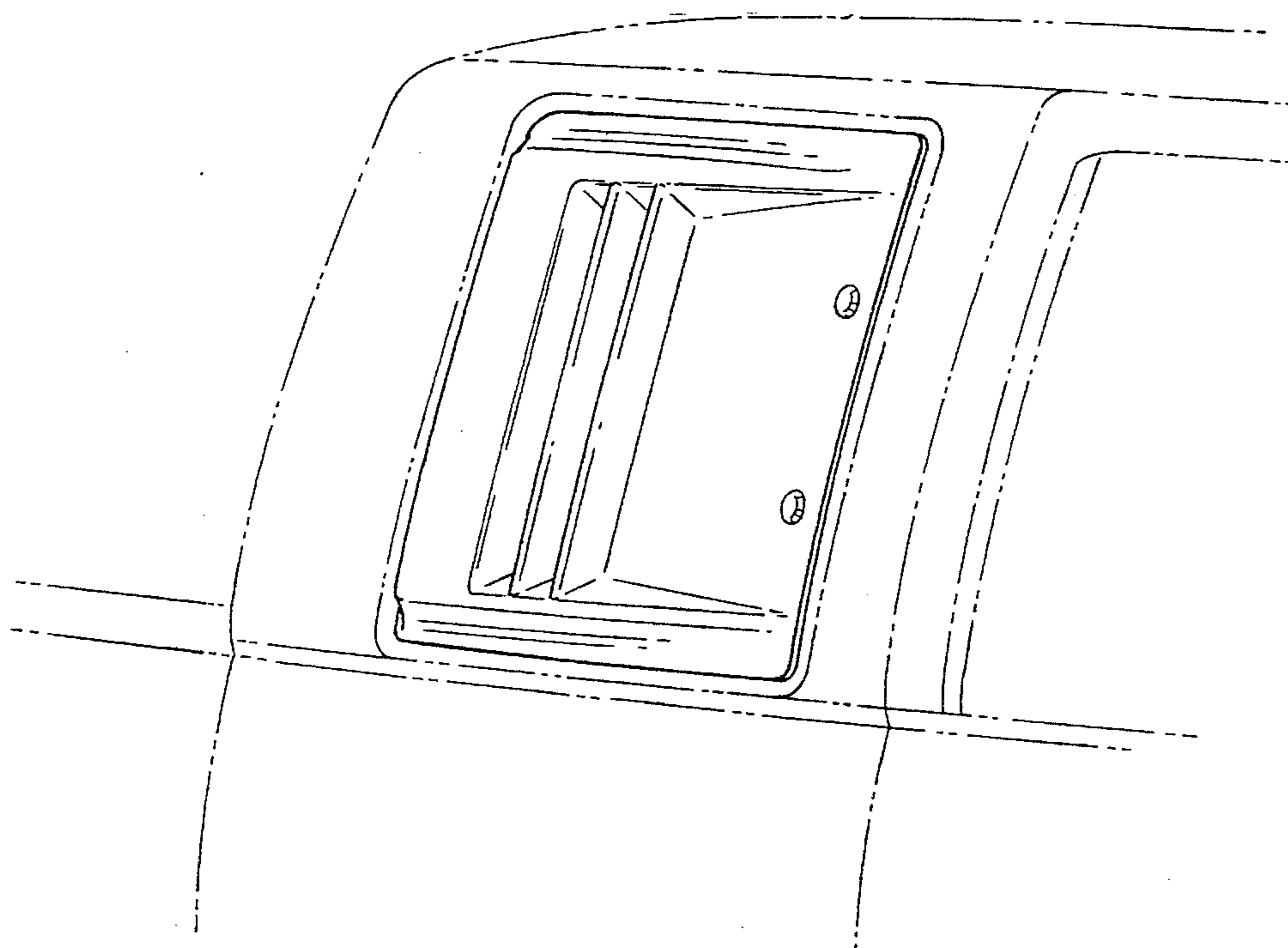

FIG. 1

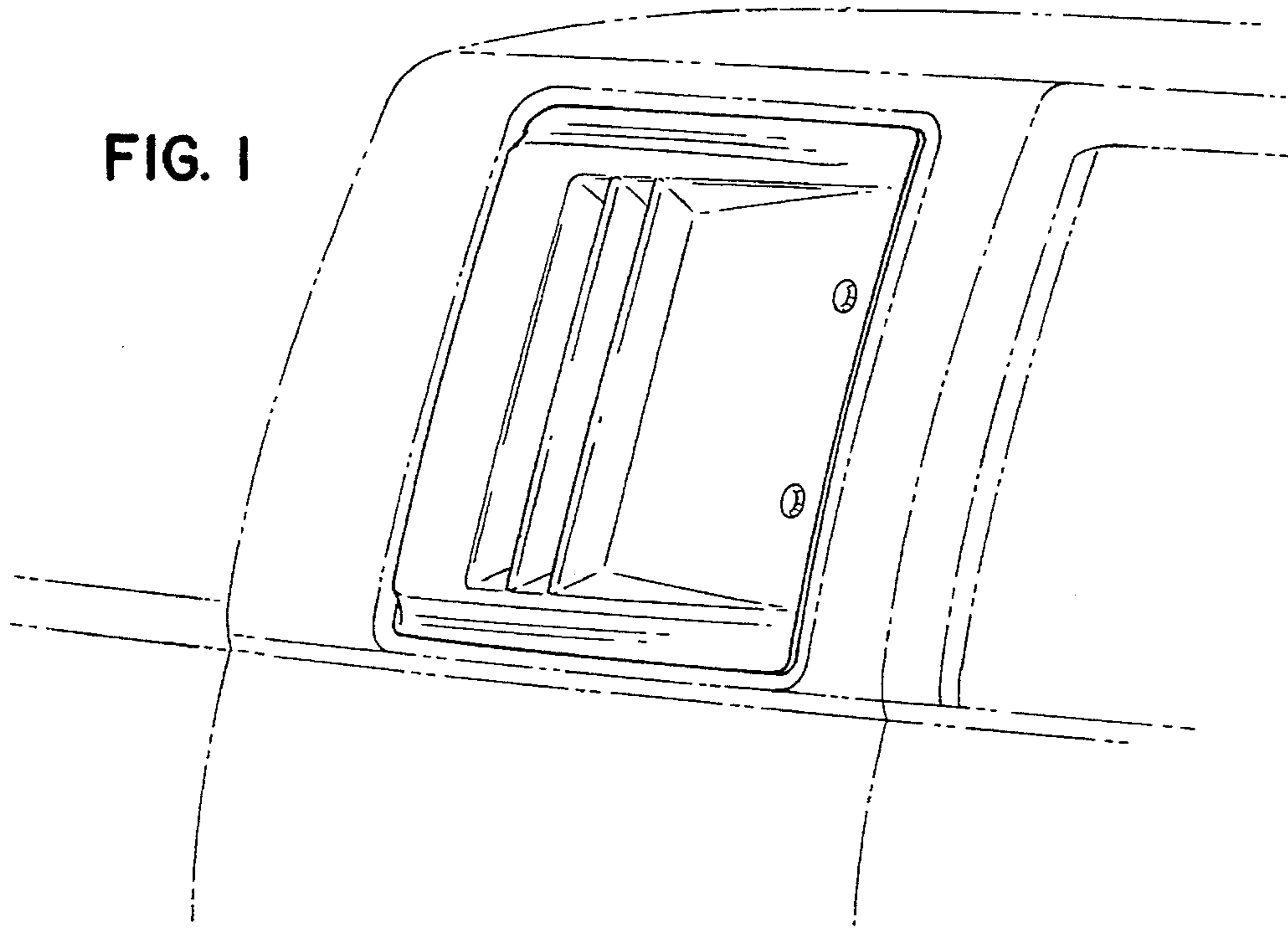

FIG. 2

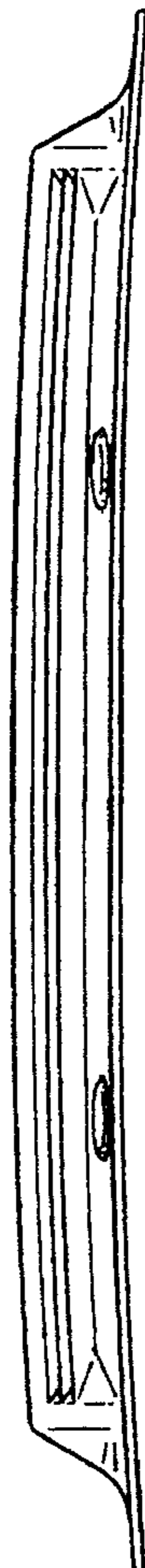
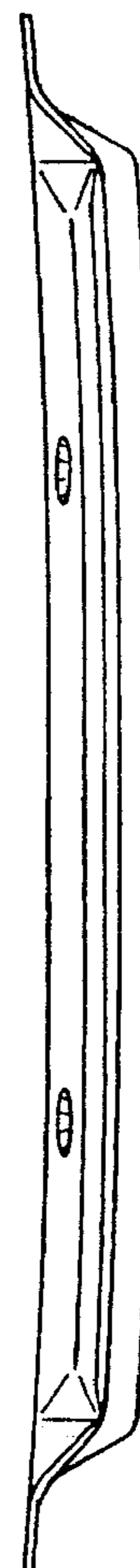

FIG. 3



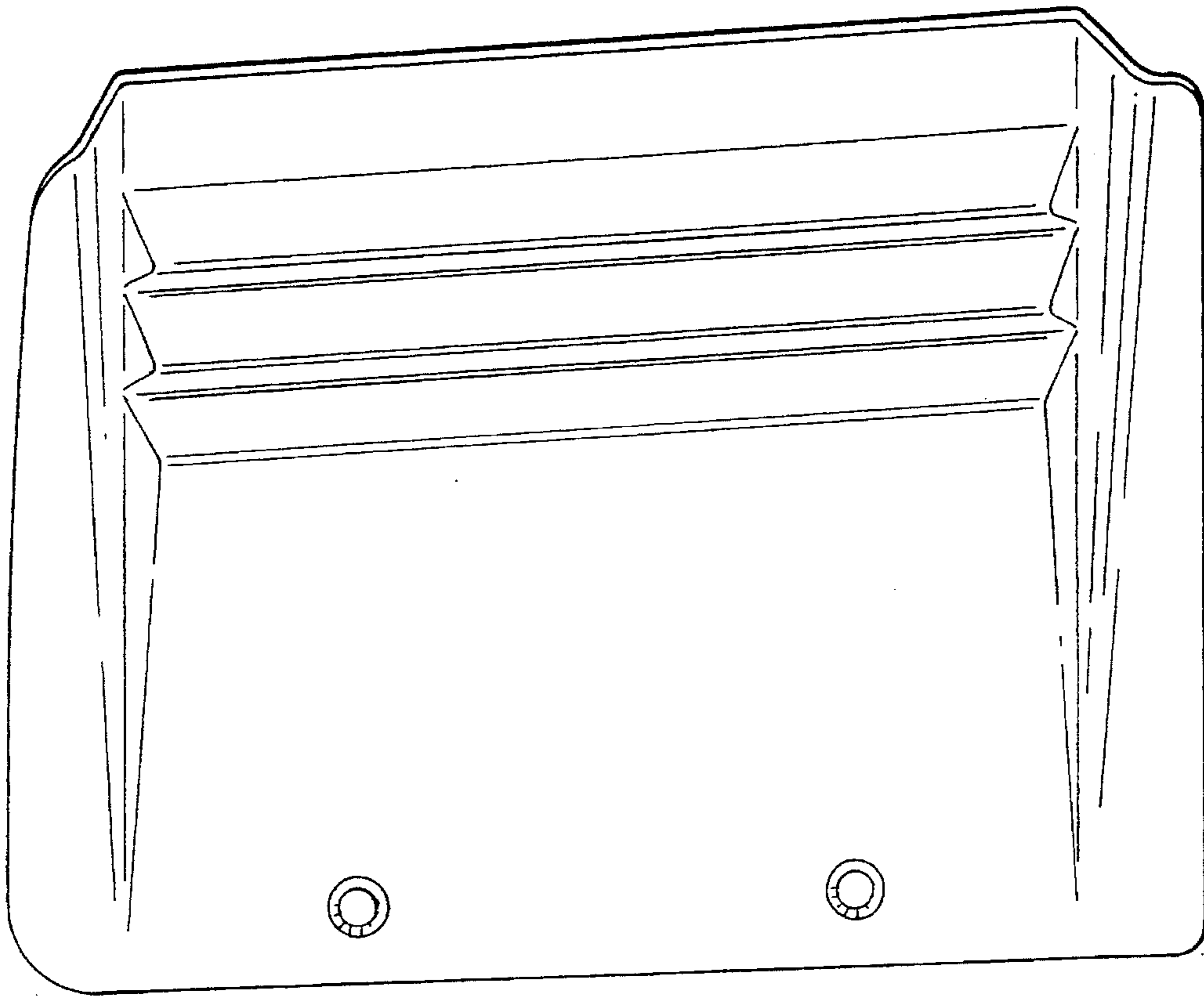

FIG. 5

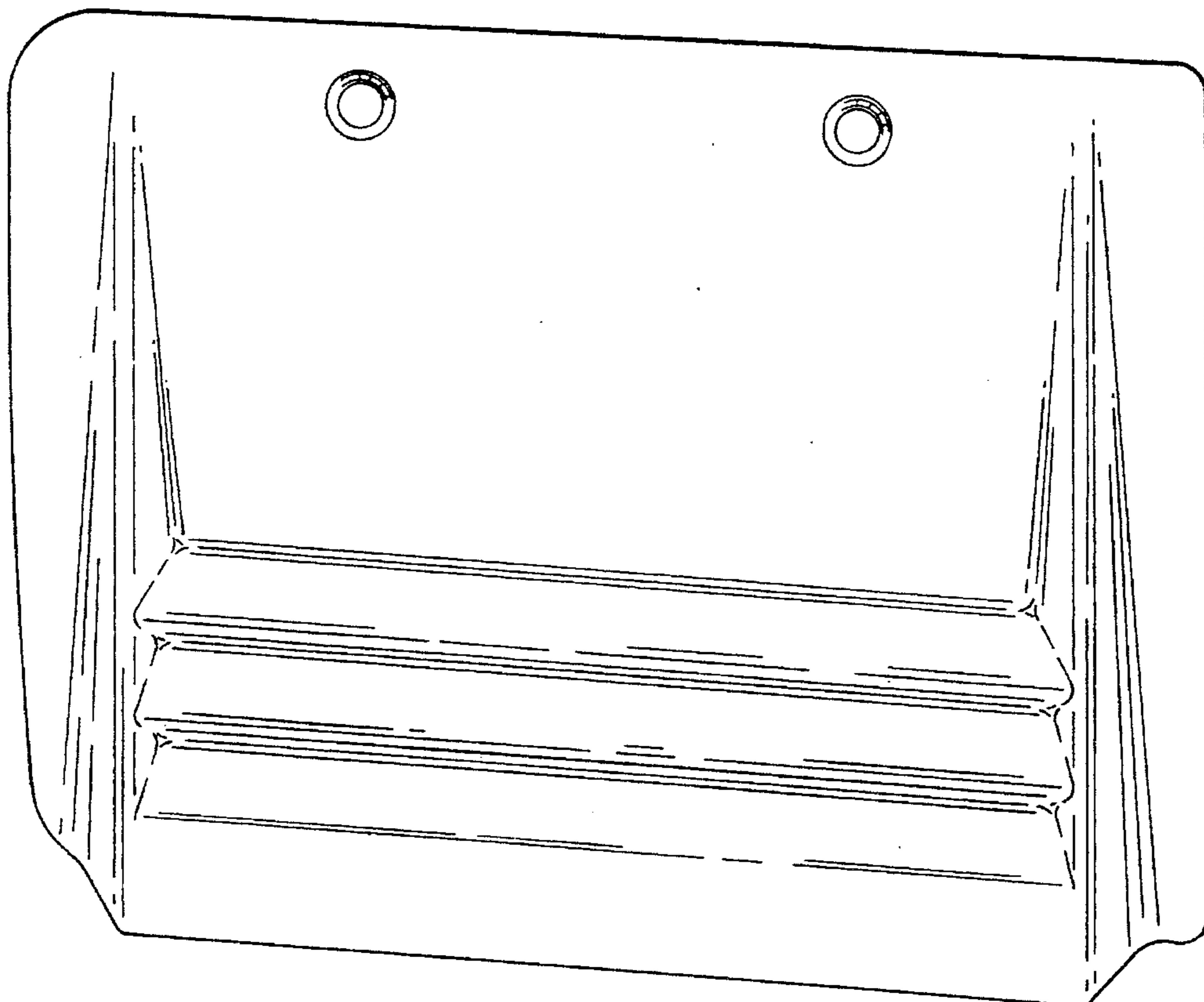

FIG. 4

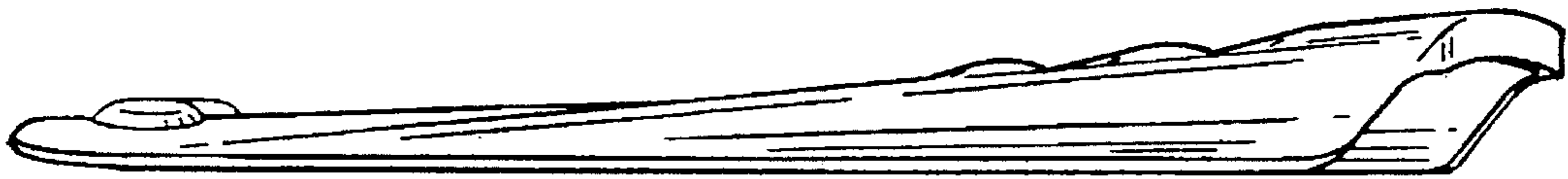

FIG. 6

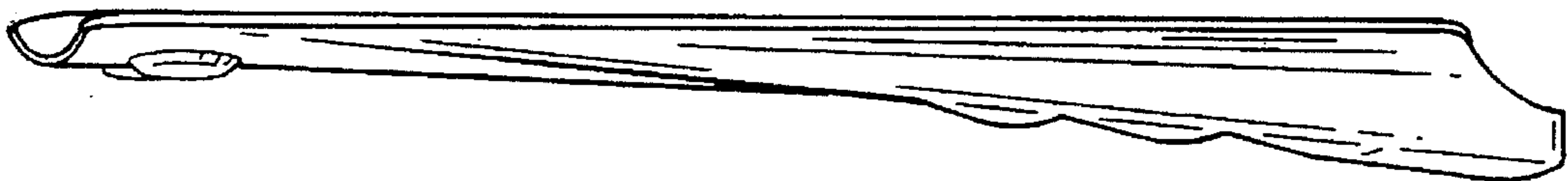

FIG. 7

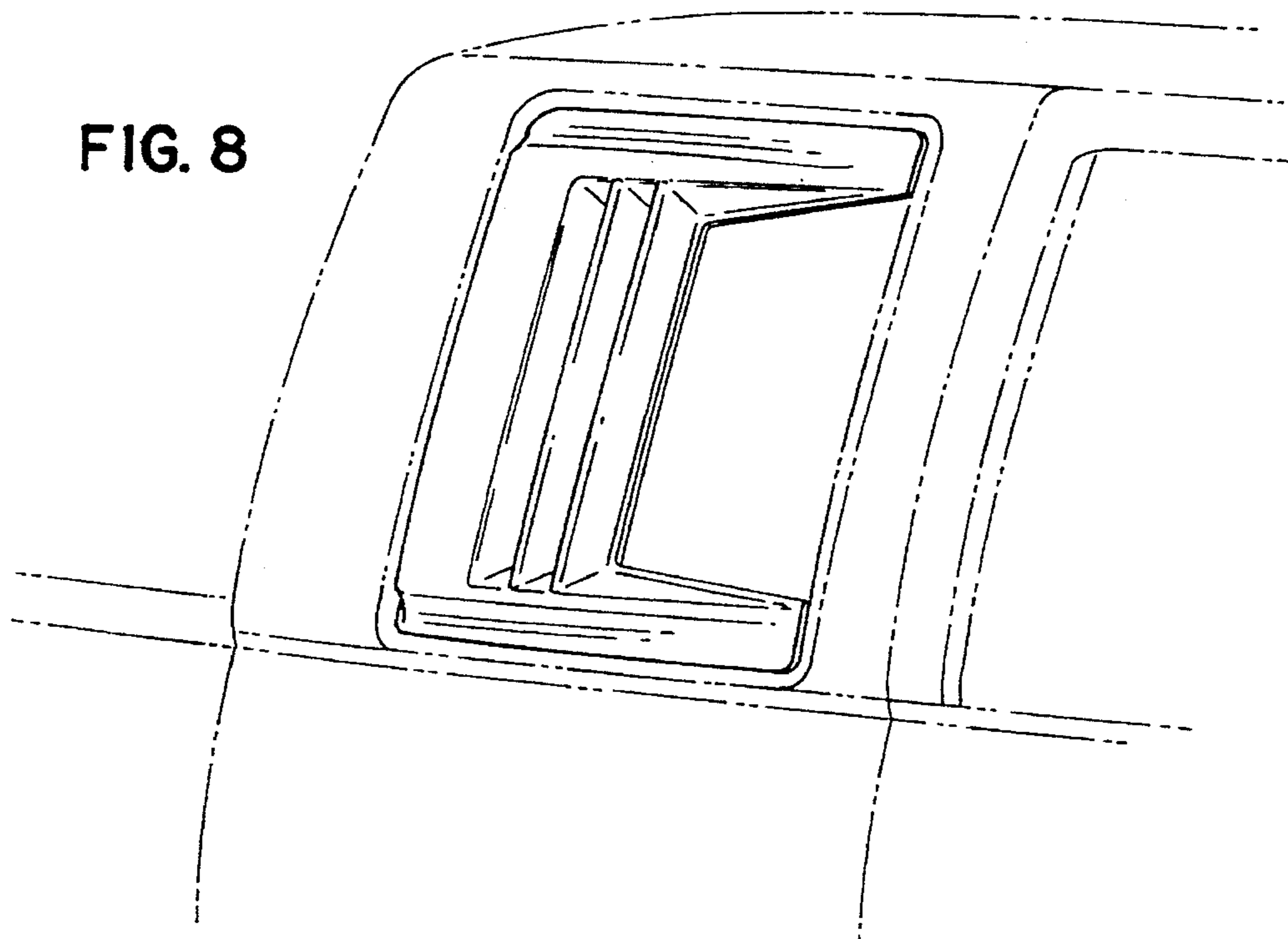

FIG. 9

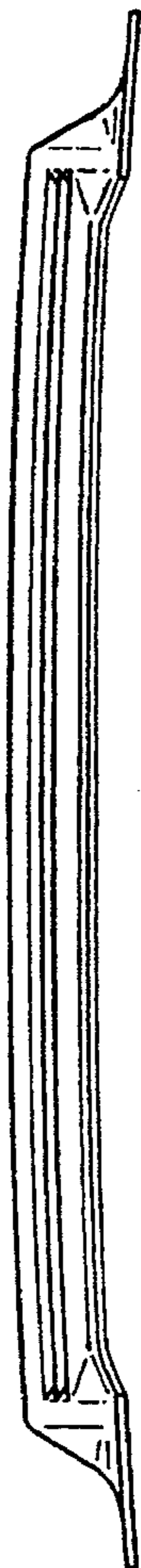
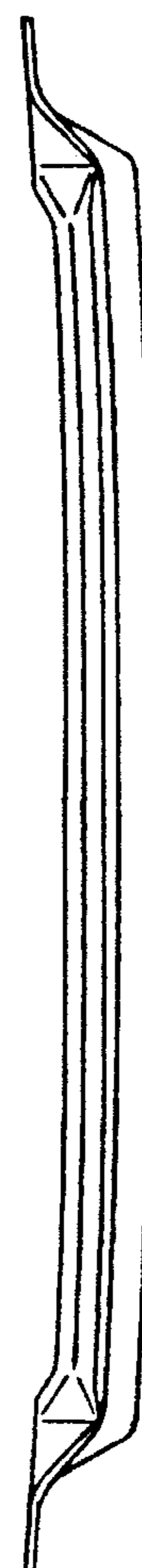

FIG. 10



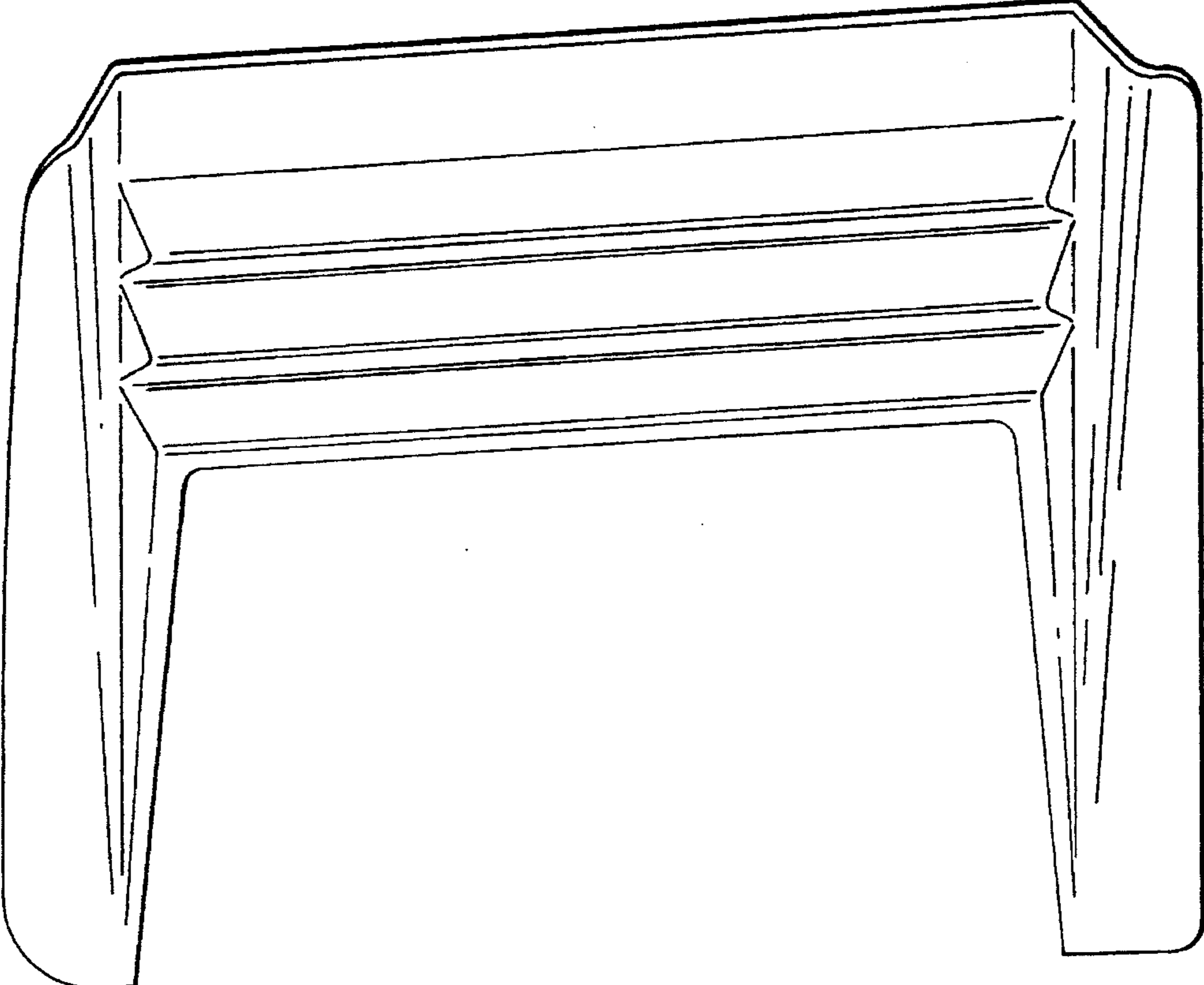

FIG. 12

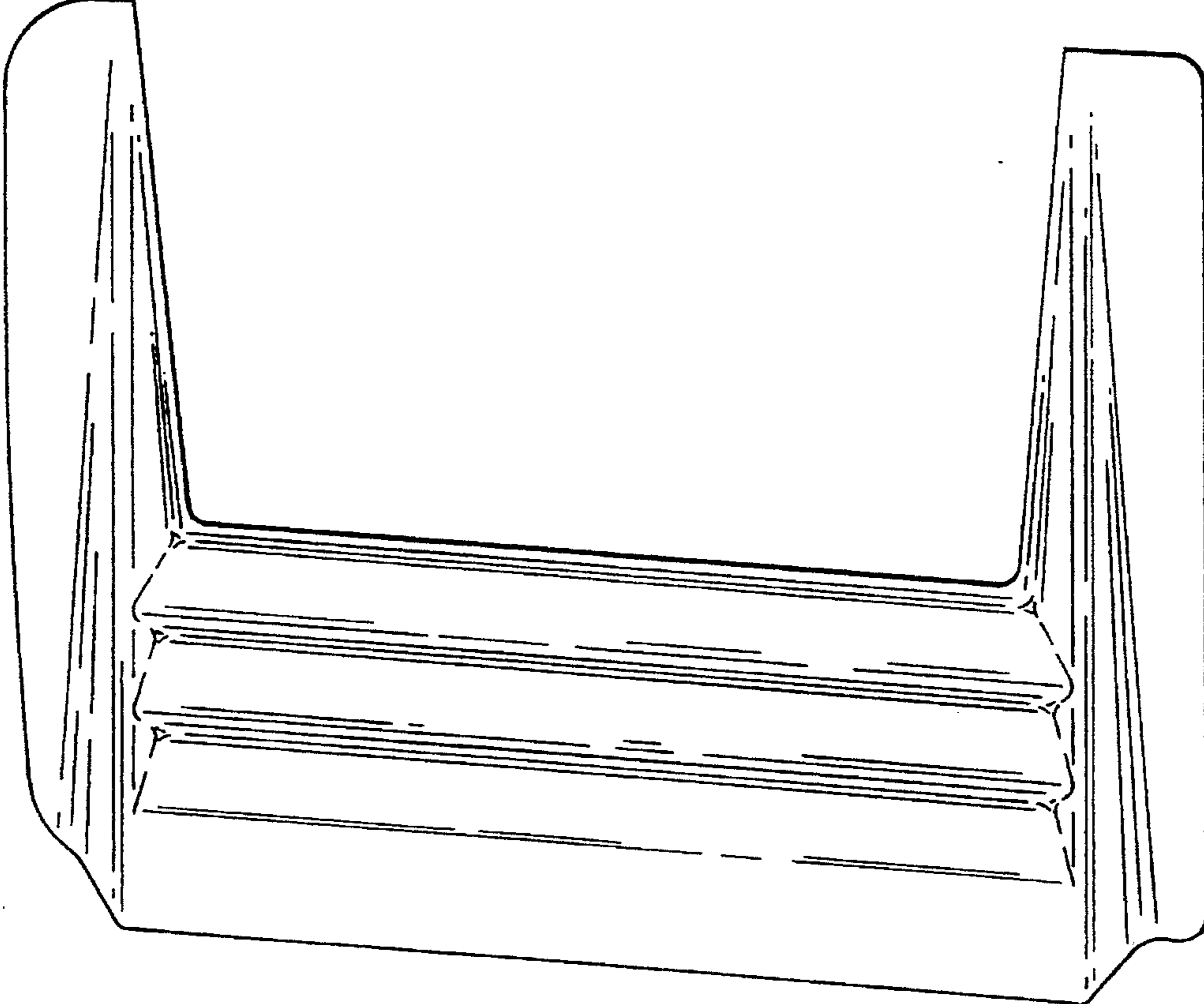

FIG. 11

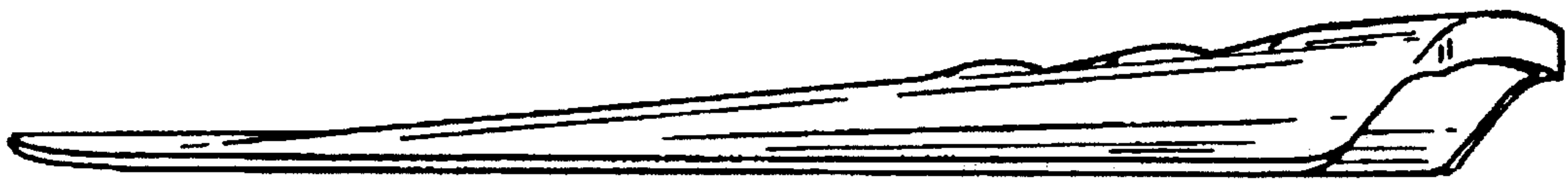

FIG. 13

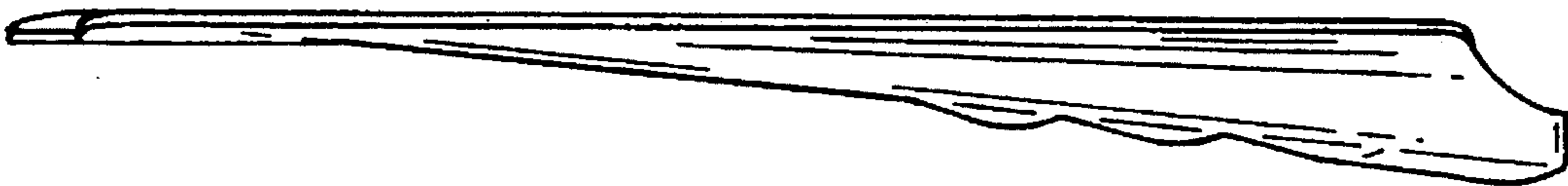

FIG. 14