



US00D375067S

United States Patent [19]
Bronstein

[11] **Patent Number: Des. 375,067**

[45] **Date of Patent: **Oct. 29, 1996**

[54] **COMBINED BUMPER AND WINCH CARRIER**
[75] Inventor: **Gary D. Bronstein**, Kelowna, Canada
[73] Assignee: **Airborne International Marketing Inc.**, Kelowna, Canada
[**] Term: **14 Years**
[21] Appl. No.: **36,723**
[22] Filed: **Mar. 27, 1995**
[52] U.S. Cl. **D12/169**
[58] Field of Search D12/169, 167;
293/102, 115, 146, 143, 132

2269566 2/1994 United Kingdom 293/115

Primary Examiner—James M. Gandy
Assistant Examiner—Stacia Sinuik
Attorney, Agent, or Firm—George A. Seaby

[57] **CLAIM**

The ornamental design for a combined bumper and winch carrier, as shown and described.

DESCRIPTION

FIG. 1 is a perspective view from above and one side of a combined bumper and winch carrier showing my new design;
FIG. 2 is a perspective view from above and the other side thereof;
FIG. 3 is a top plan view thereof;
FIG. 4 is a bottom plan view of FIG. 3;
FIG. 5 is a left side elevational view of FIG. 3;
FIG. 6 is a right side elevational view of FIG. 3;
FIG. 7 is a front elevational view of FIG. 3; and,
FIG. 8 is a rear elevational view of FIG. 3.

[56] **References Cited**

U.S. PATENT DOCUMENTS

D. 248,229 6/1978 Baker D12/169
D. 308,037 5/1990 Aiken D12/169
4,469,360 9/1984 Drury 293/102

FOREIGN PATENT DOCUMENTS

06305381 11/1994 Japan 293/115

1 Claim, 5 Drawing Sheets

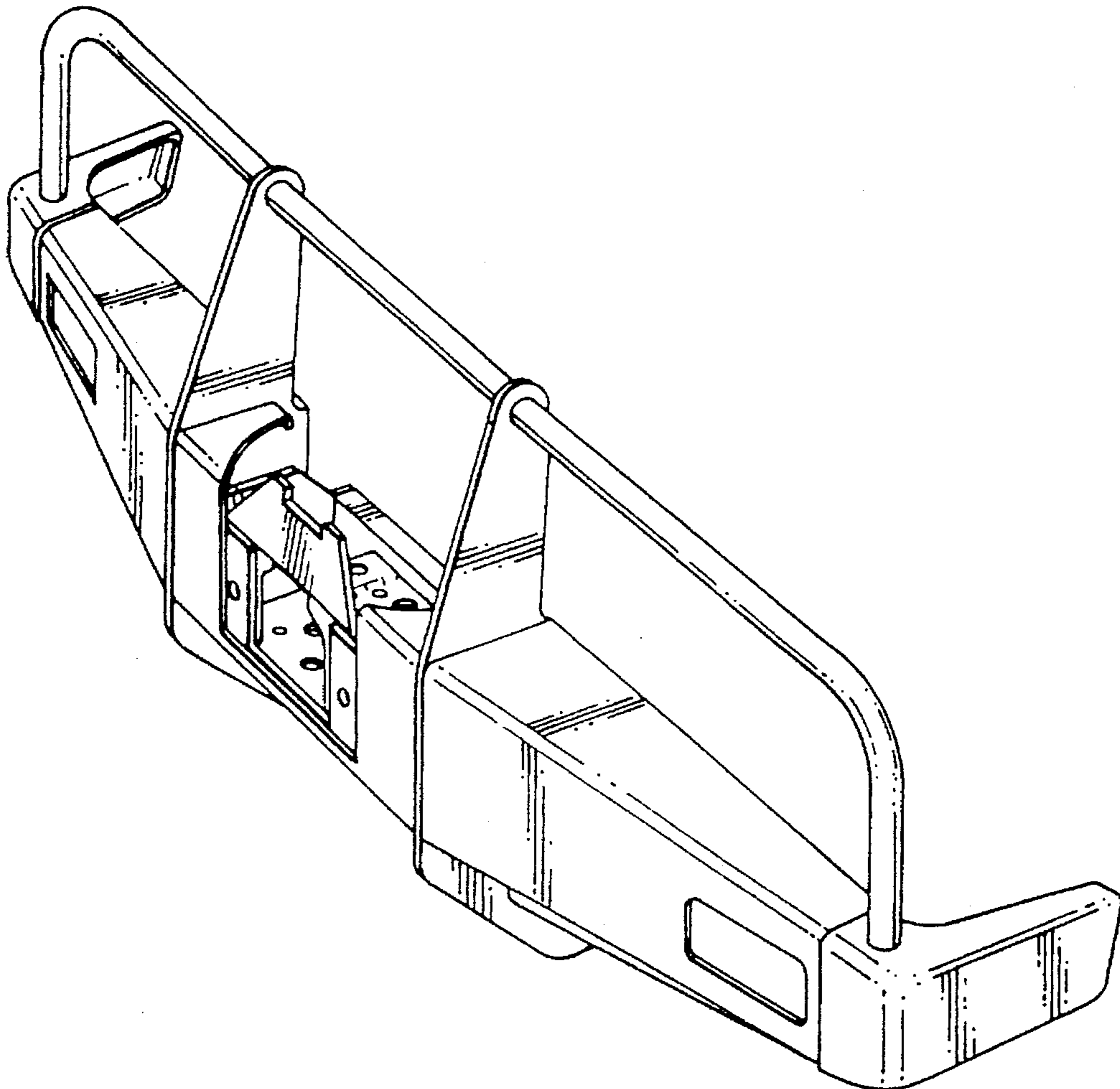

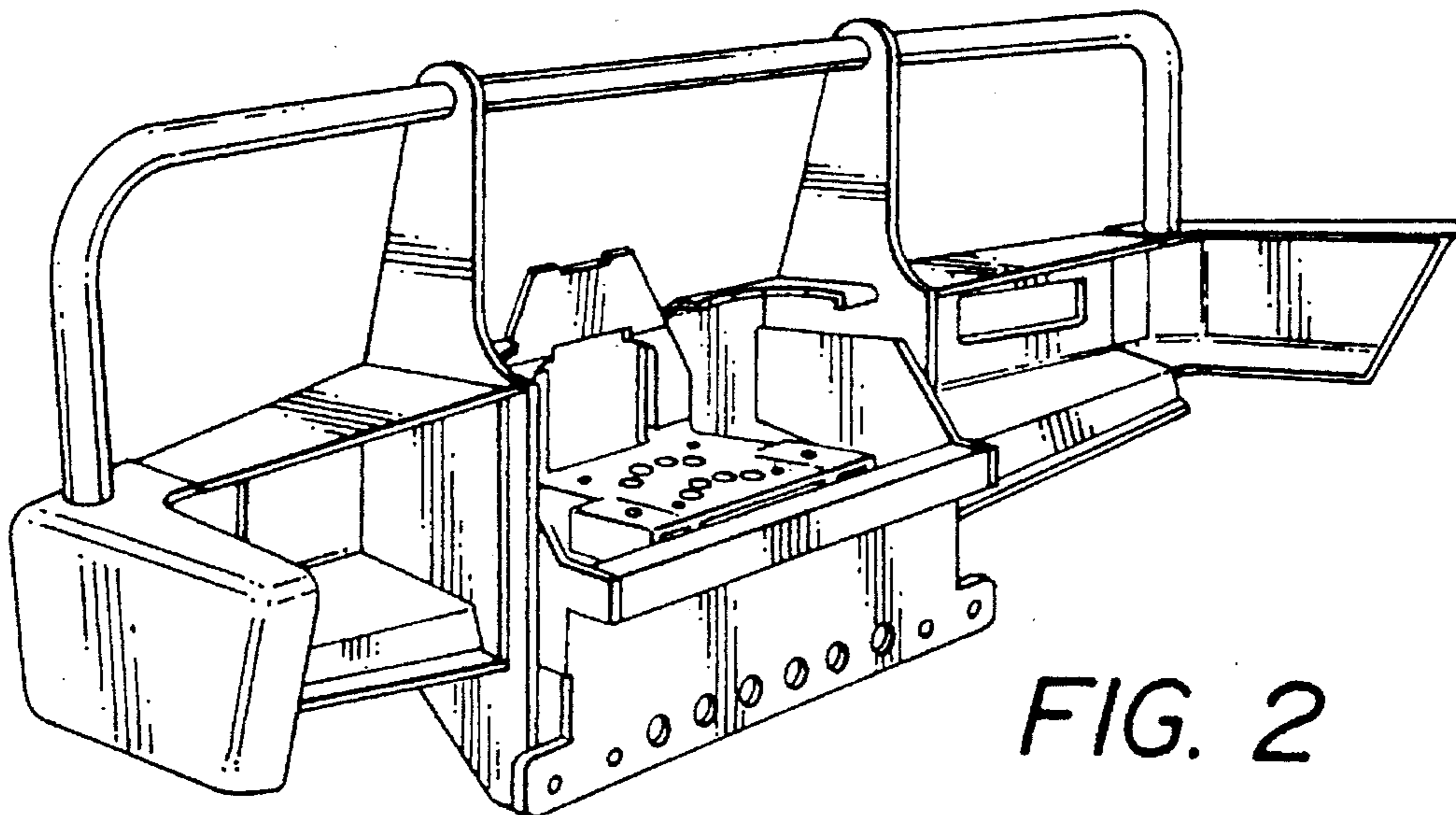
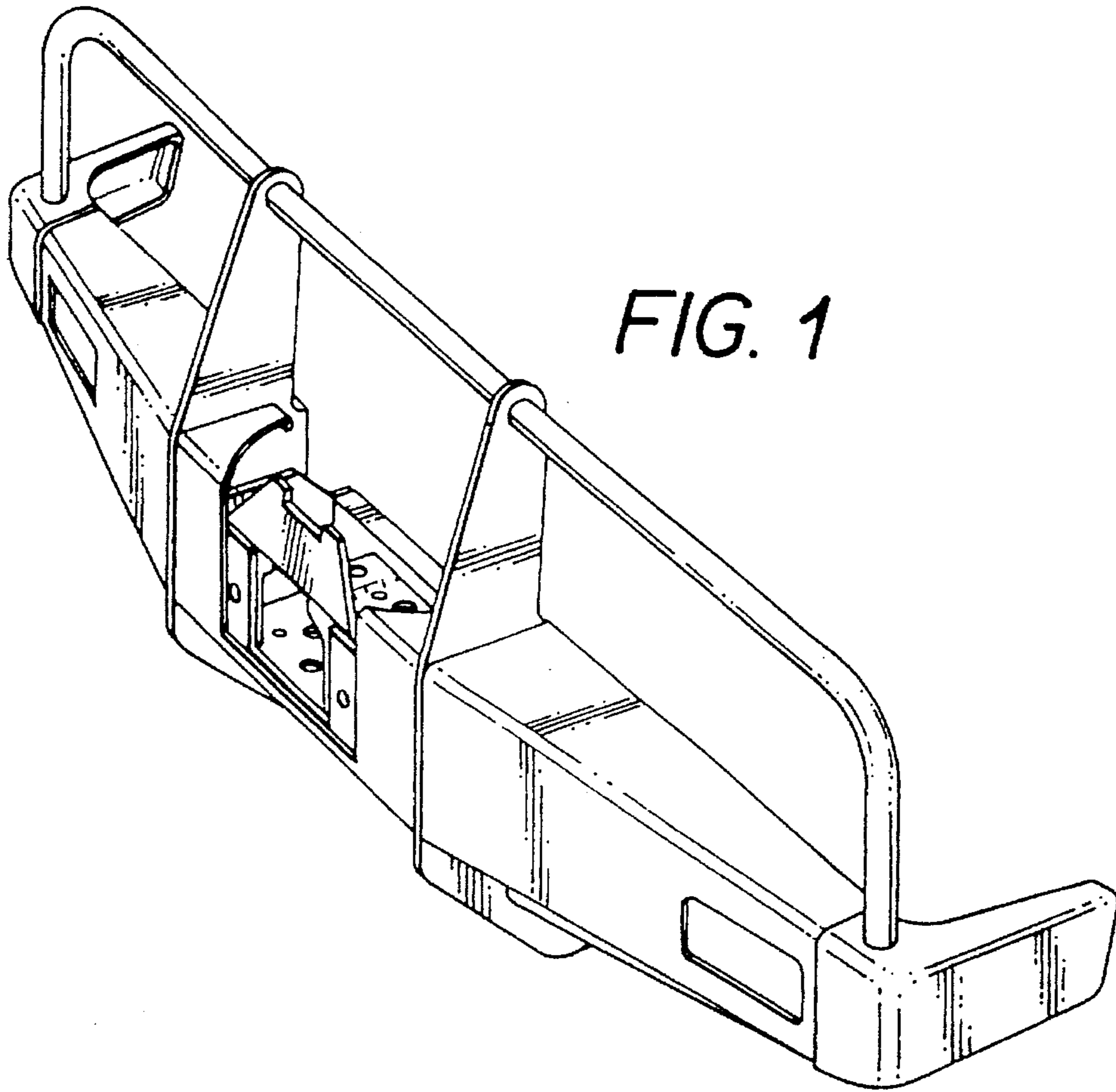

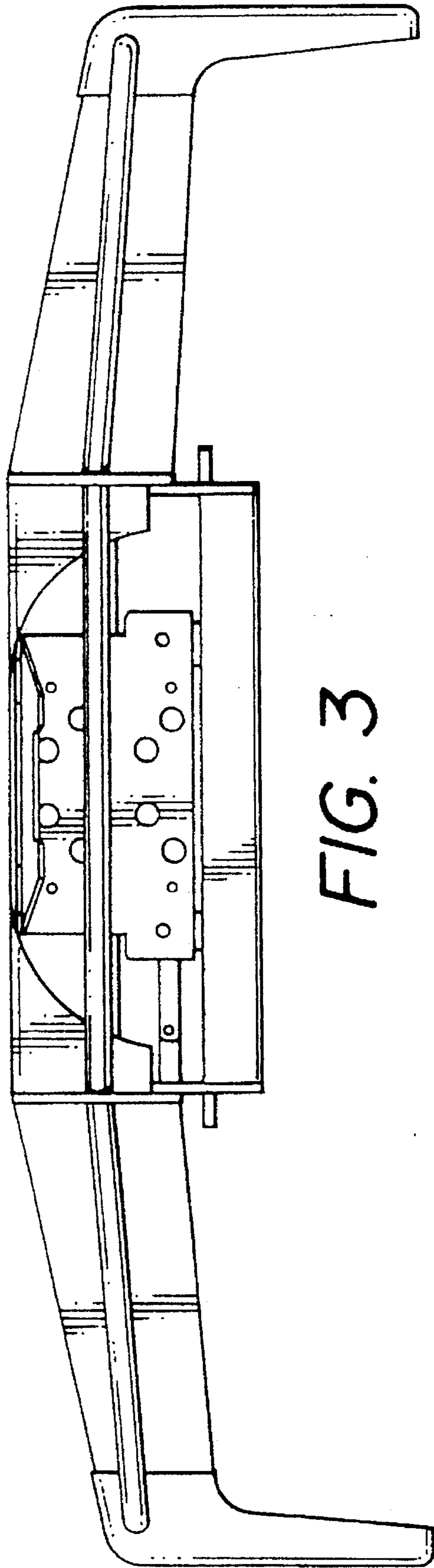

FIG. 3

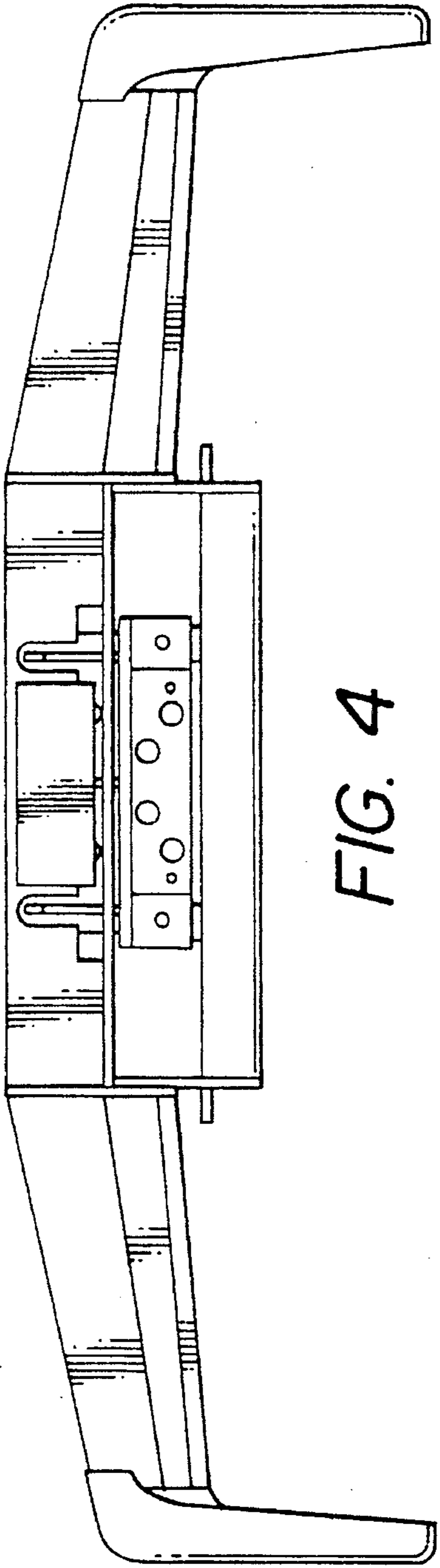

FIG. 4

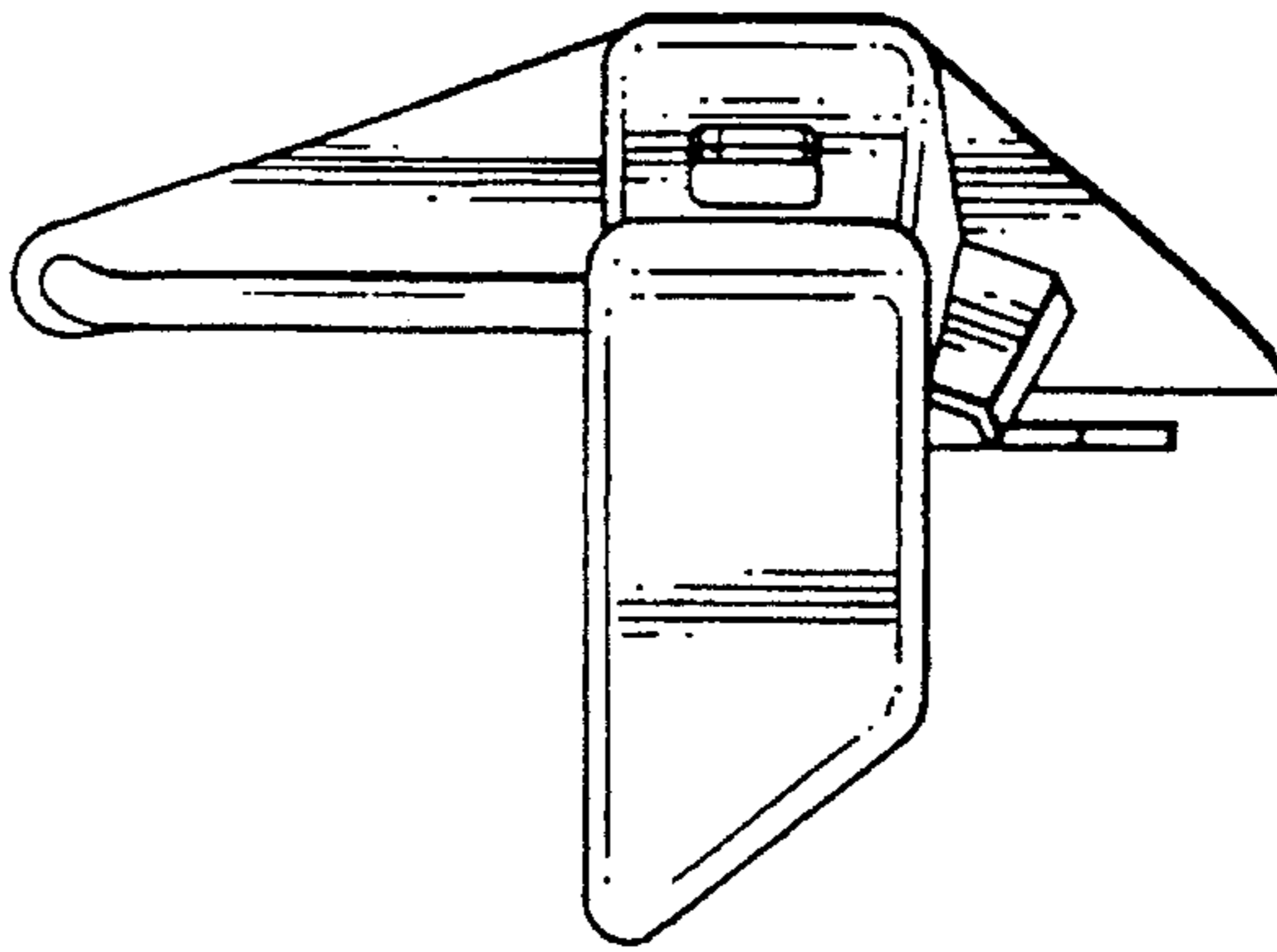

FIG. 6

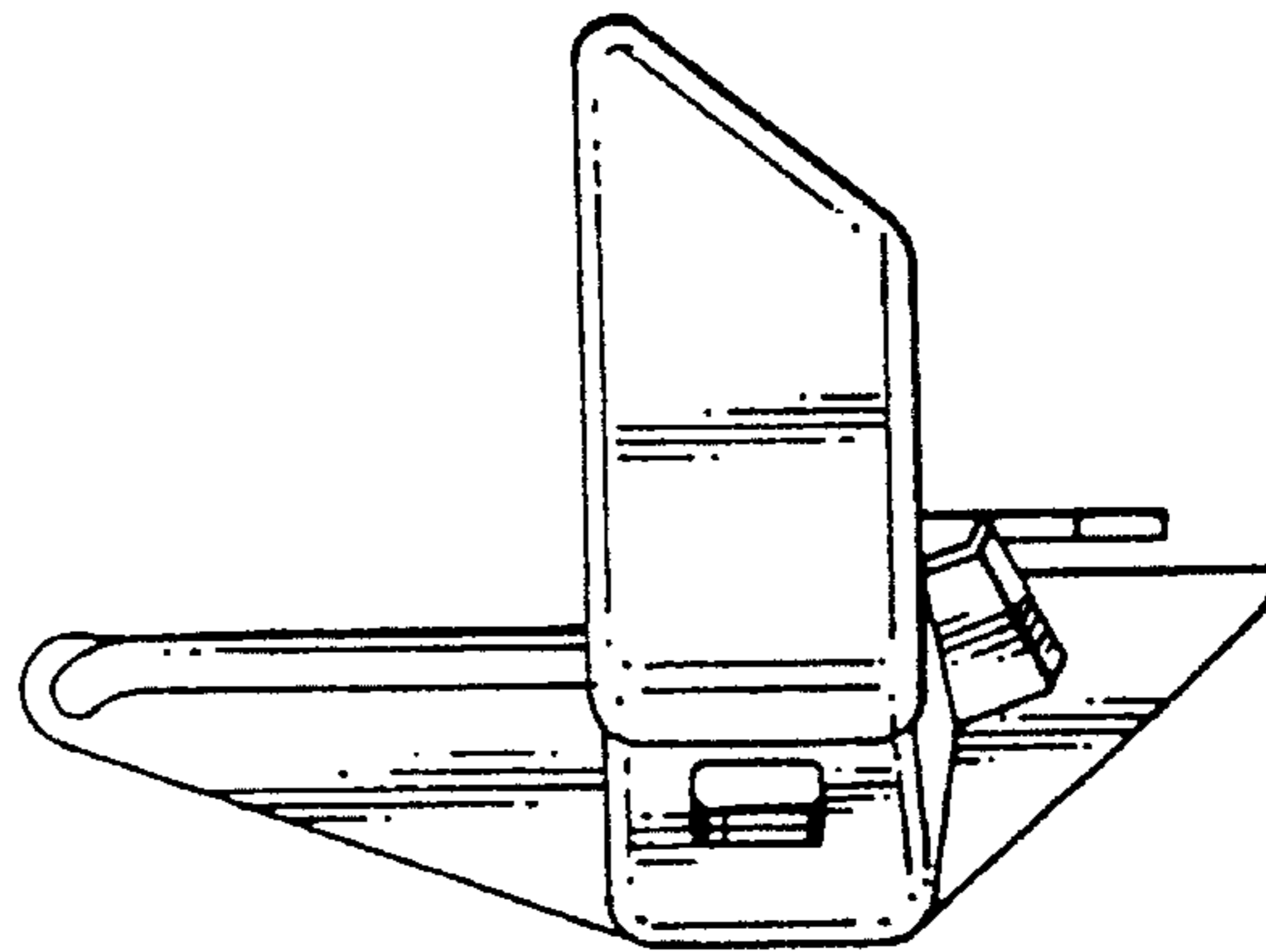

FIG. 5

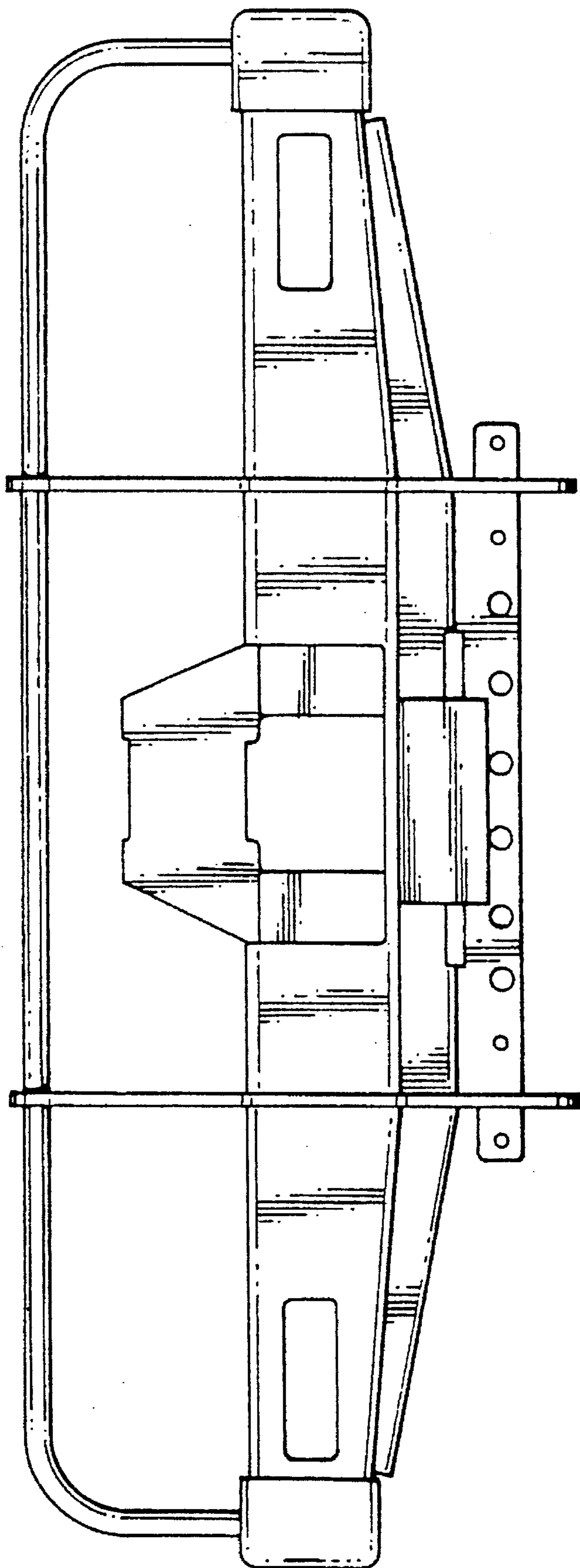

FIG. 7

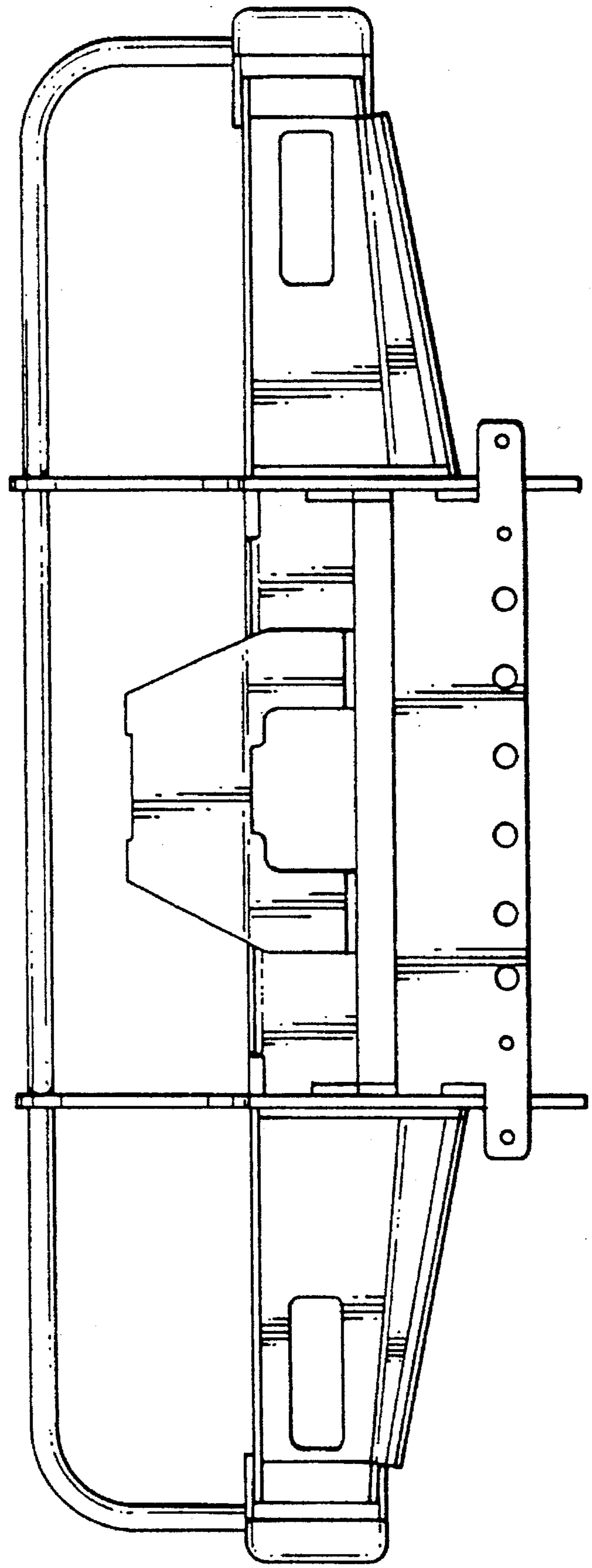

FIG. 8