



US00D375036S

# United States Patent [19]

[11] Patent Number: Des. 375,036

David et al.

[45] Date of Patent: \*\*Oct. 29, 1996

## [54] HANDLE GRIP

Attorney, Agent, or Firm—Foley & Lardner

[75] Inventors: **Thomas J. David**, Worthington, Ohio;  
**Ernest D. Labarre**, Waunakee; **Jerrold N. Austin**, Baraboo, both of Wis.

## [57] CLAIM

The ornamental design for a handle grip, as shown and described.

[73] Assignee: **Fiskars Inc.**, Madison, Wis.

## DESCRIPTION

[\*\*] Term: **14 Years**

[21] Appl. No.: **38,974**

[22] Filed: **May 17, 1995**

[52] U.S. Cl. .... **D8/303**; D8/300

[58] Field of Search ..... D8/303; 74/551.8,  
74/551.9, 502.2, 558.5; 16/110 R, 110.5,  
111.1, DIG. 12

FIG. 1 is a perspective view of the handle grip showing our new design;

FIG. 2 is a top plan view thereof;

FIG. 3 is a front elevational view thereof with the rear view being a mirror image thereof;

FIG. 4 is a right side elevational view thereof;

FIG. 5 is a bottom plan view thereof;

FIG. 6 is a left side elevational view thereof;

FIG. 7 is a sectional view taken along line 7—7 of FIG. 3;

FIG. 8 is a front elevational view of a second embodiment of our new design, the rear view being a mirror image thereof, the bottom plan view being the same as FIG. 5, and the right side elevational view being the same as FIG. 4;

FIG. 9 is a perspective view of FIG. 8;

FIG. 10 is a top plan view of FIG. 8; and,

FIG. 11 is a left side elevational view of FIG. 8.

The broken line illustration of a portion of the handle is for illustrative purposes only and forms no part of the claimed design.

## [56] References Cited

### U.S. PATENT DOCUMENTS

D. 267,147	12/1987	Jannard	.....	D8/303
D. 337,505	7/1993	Ming-Chang	.....	D8/303
D. 340,636	10/1993	Ming-Chang	.....	D8/303
D. 352,443	11/1994	Chen	.....	D8/303
D. 353,484	12/1994	Miller	.....	D21/230
D. 354,216	11/1995	Chen	.....	D8/363
4,934,024	6/1990	Sexton	.....	16/111 R
4,974,286	12/1990	Stowell	.....	D8/303

### FOREIGN PATENT DOCUMENTS

2236721	10/1989	United Kingdom	.....	74/558.5
---------	---------	----------------	-------	----------

### OTHER PUBLICATIONS

Bike Nashbar, Spring 1994, p. 55, the specialized auto pilot comp grips.

Primary Examiner—Melody N. Brown

1 Claim, 3 Drawing Sheets

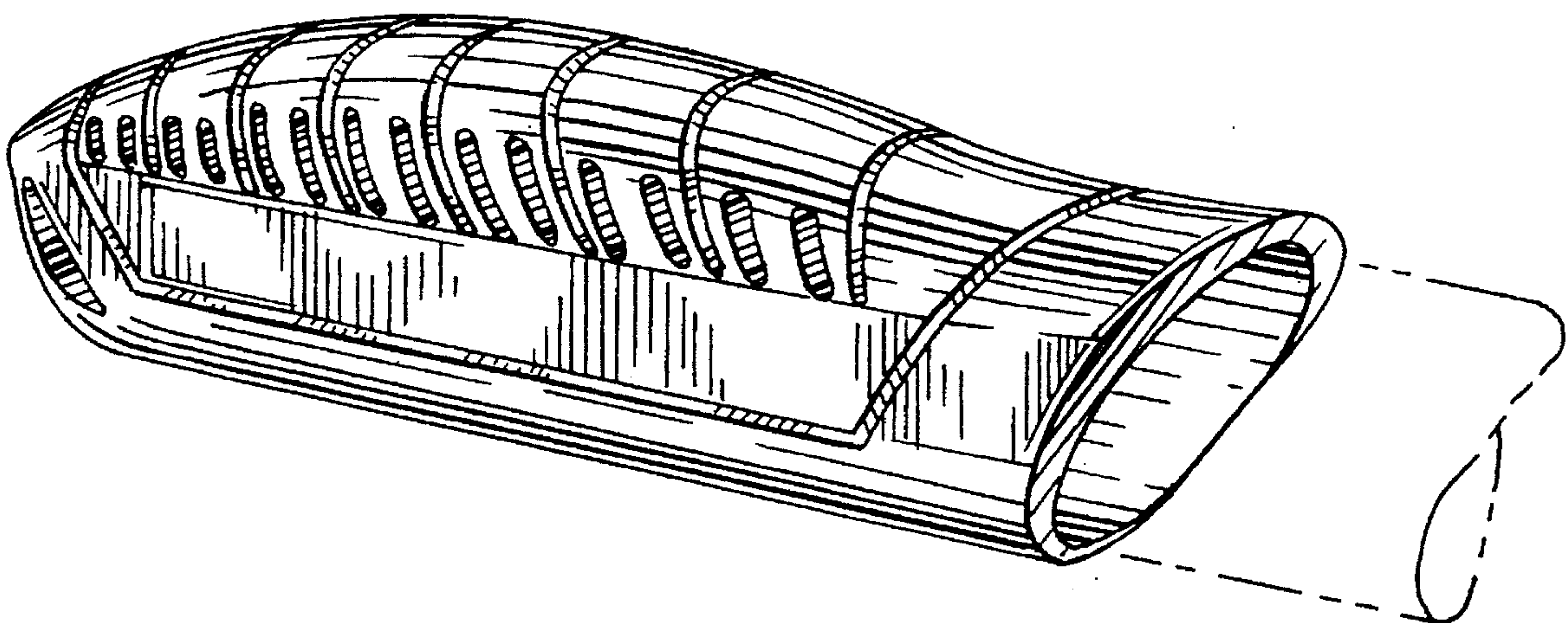

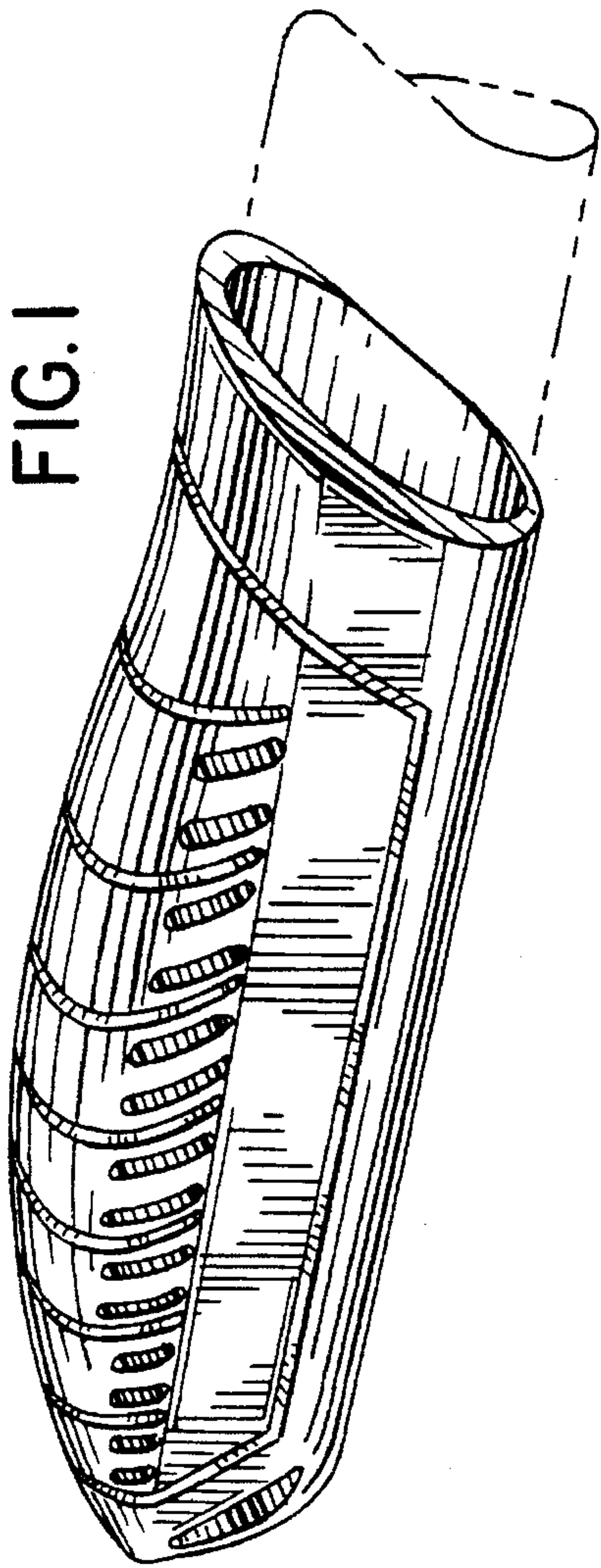

FIG. 1

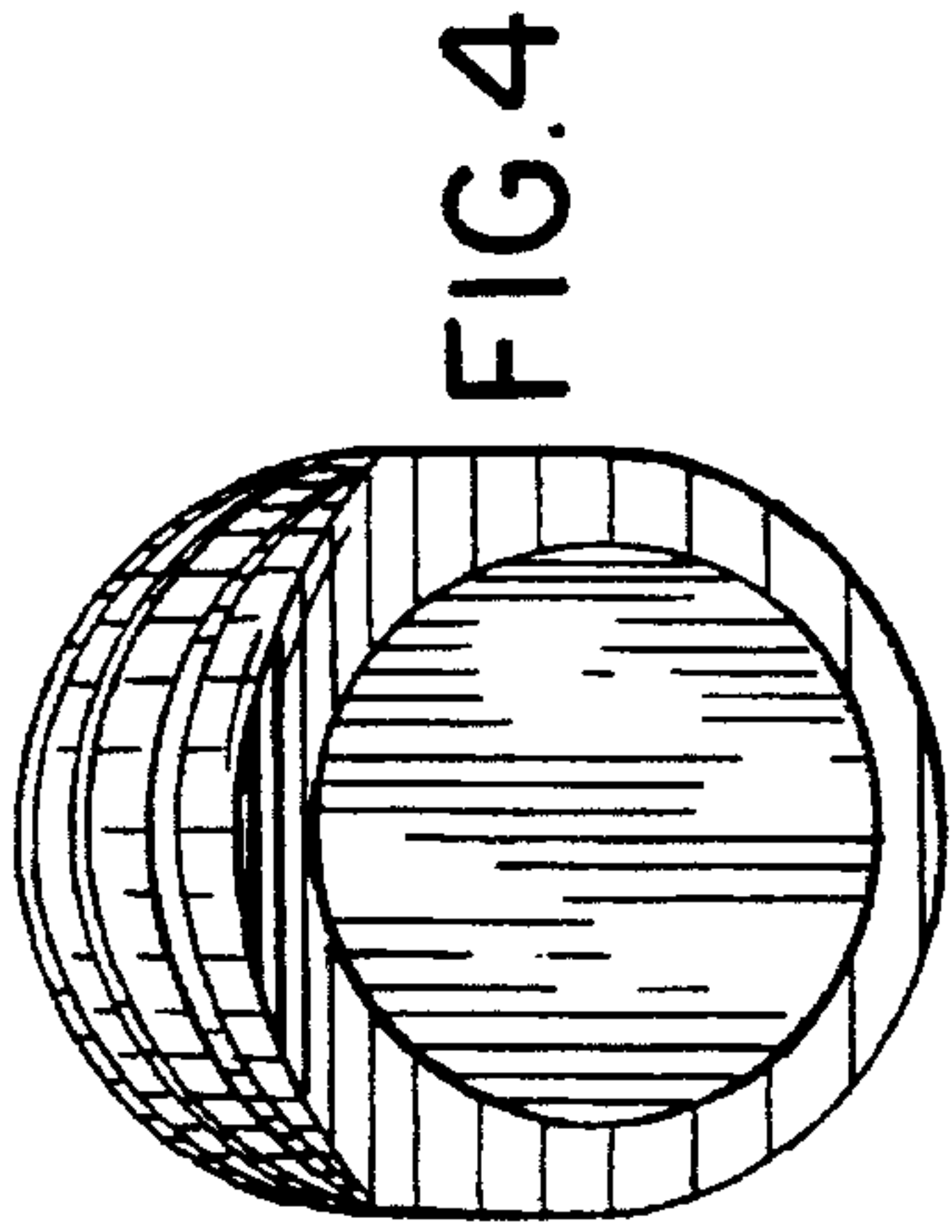

FIG. 4

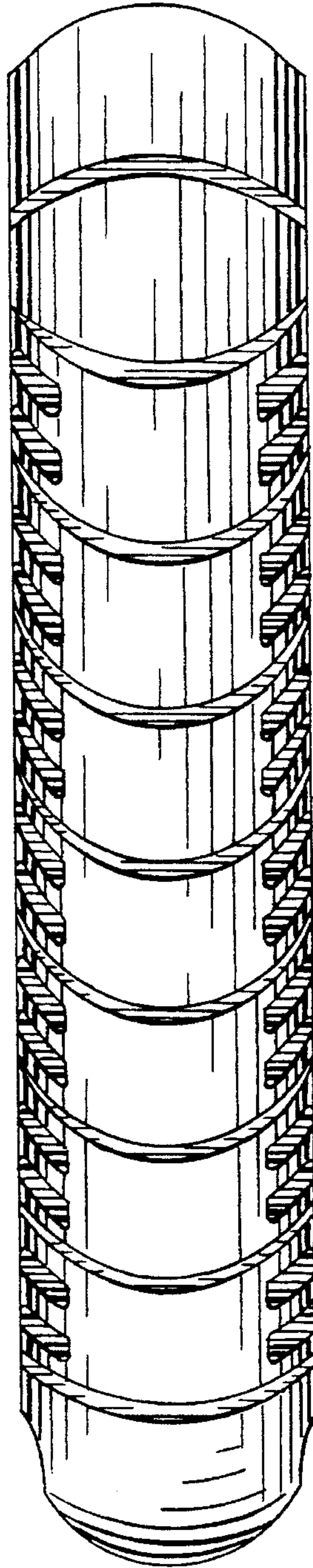

FIG. 2

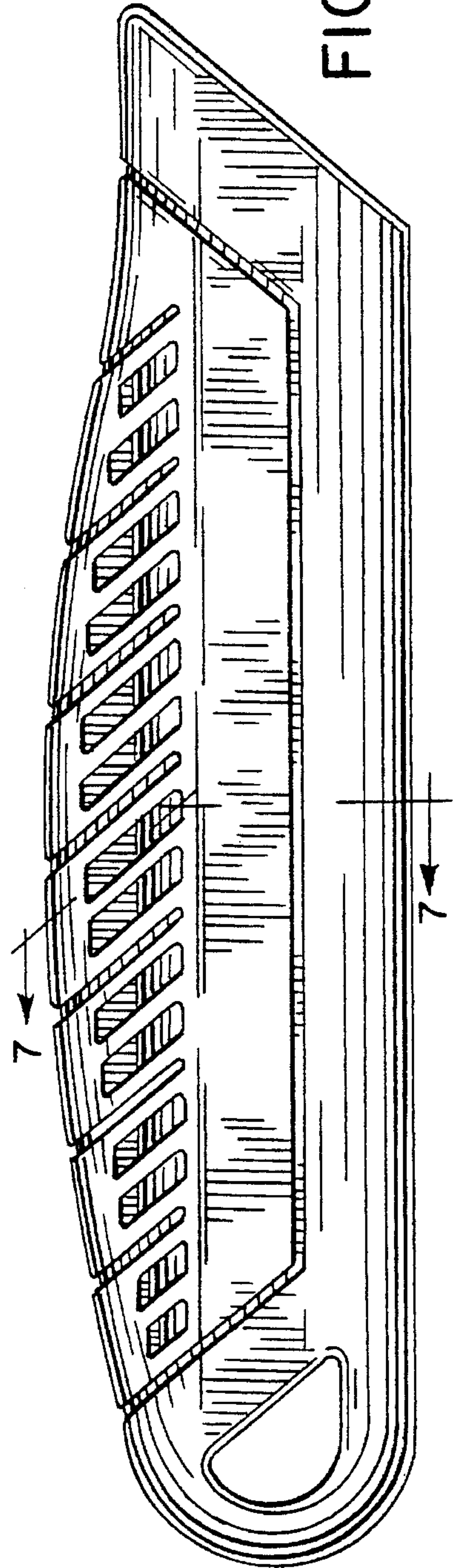

FIG. 3



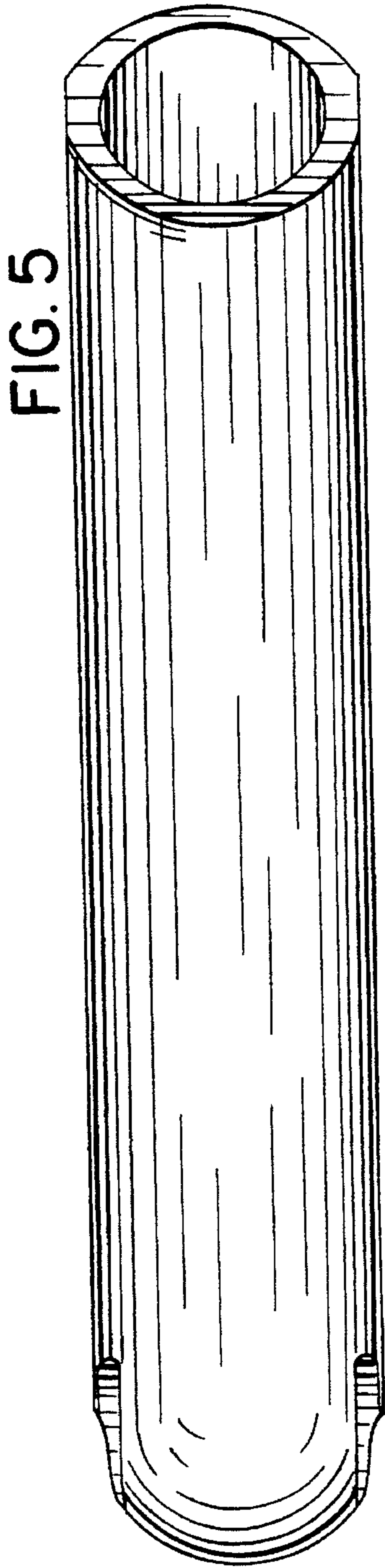

FIG. 5

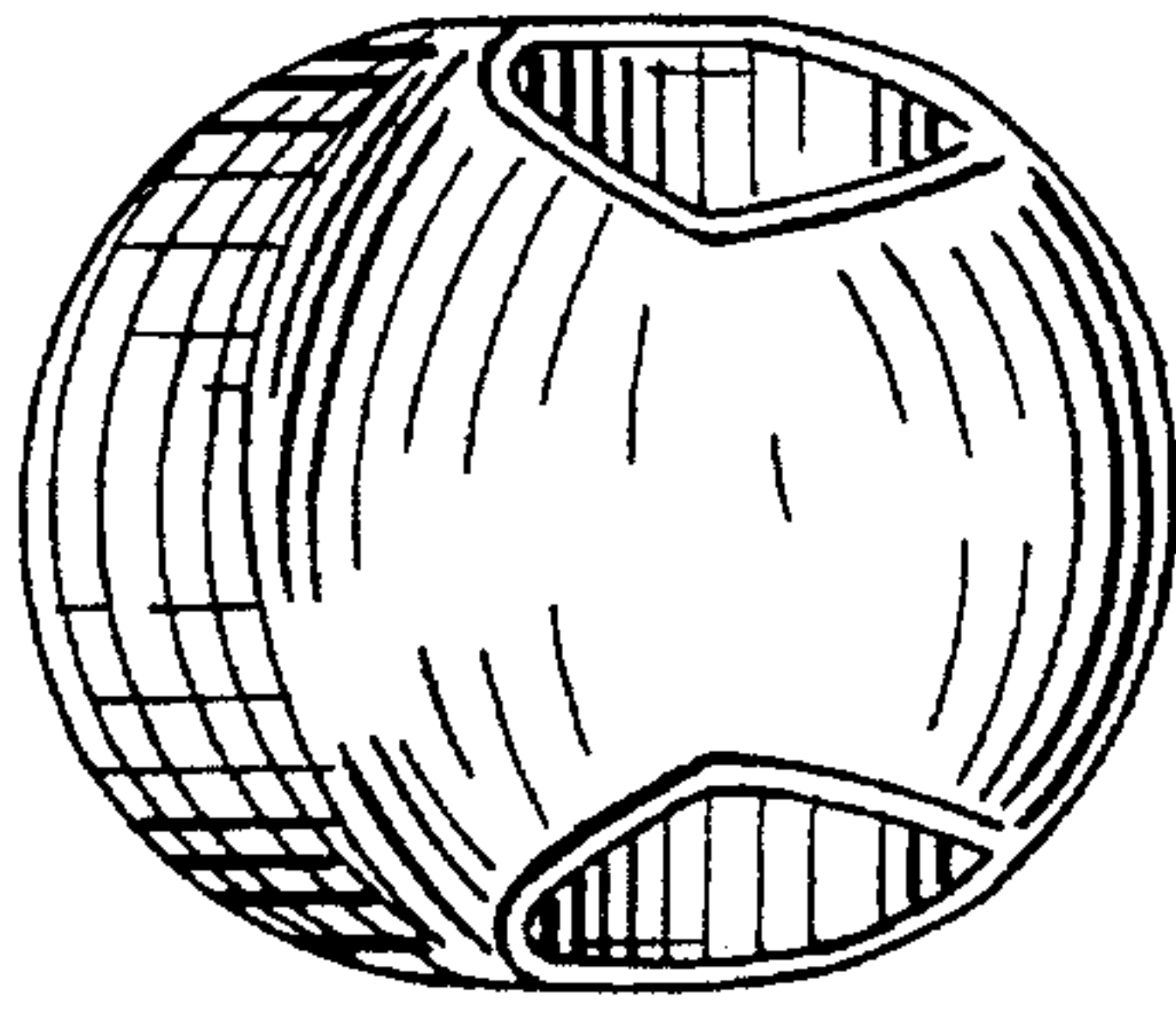

FIG. 6

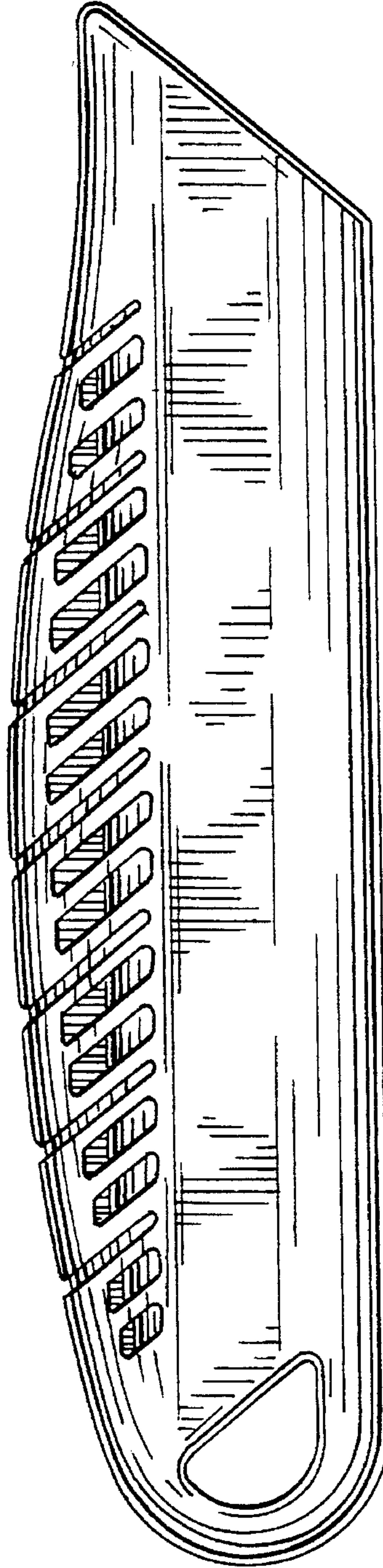

FIG. 8

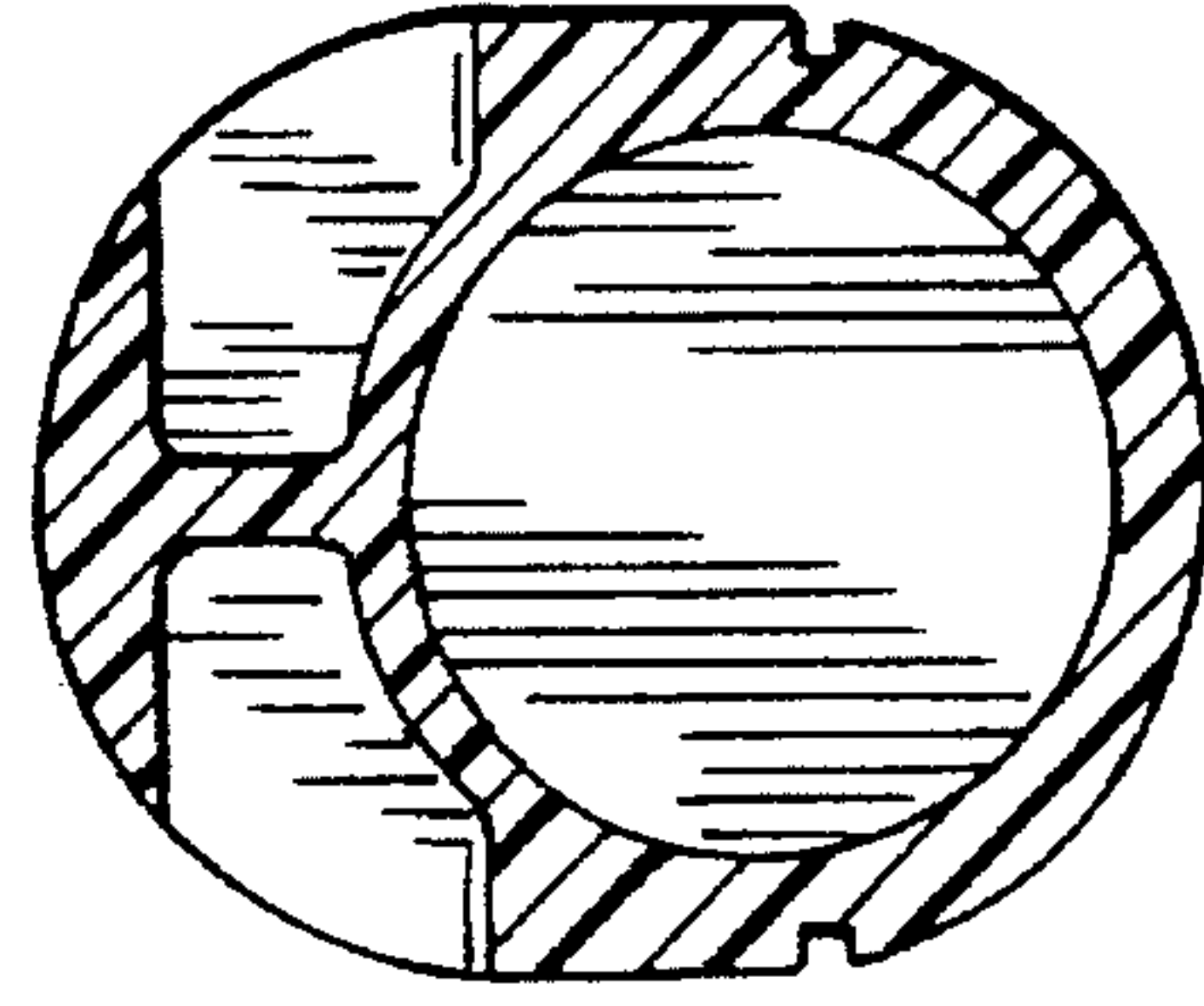

FIG. 7

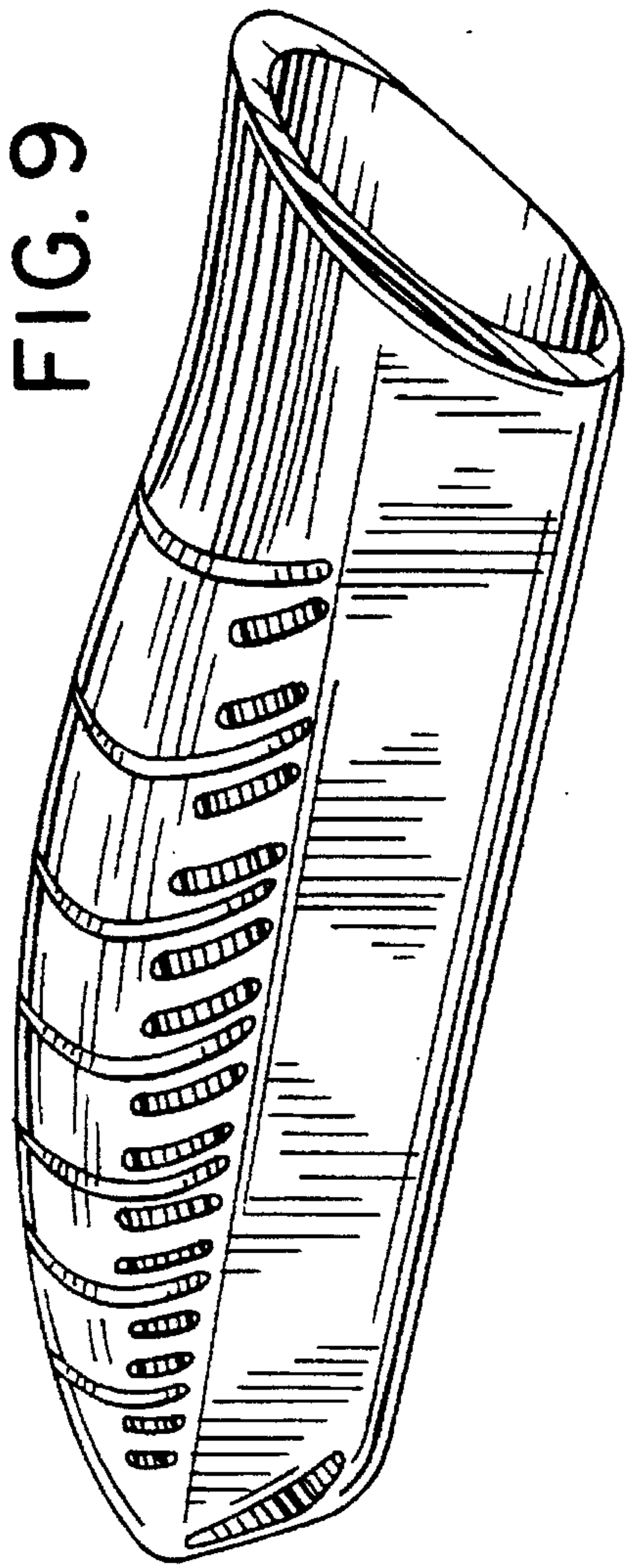

FIG. 9

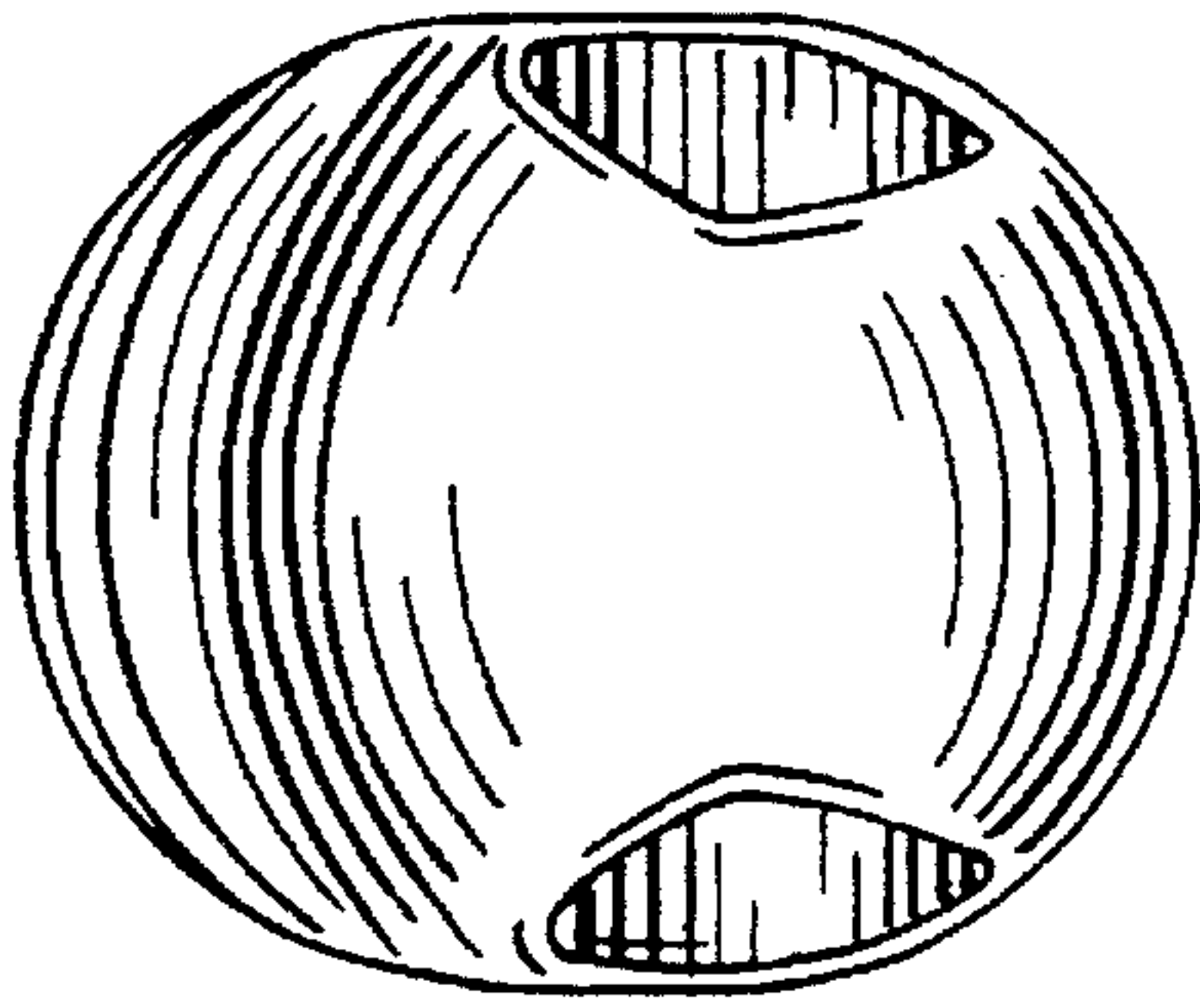

FIG. 11

FIG. 10

