



US00D375006S

United States Patent [19]

Hakansson

[11] Patent Number: **Des. 375,006**

[45] Date of Patent: ****Oct. 29, 1996**

[54] **DOUBLE CORRUGATED CARDBOARD TABLE**

[75] Inventor: **Anette Hakansson**, Tequesta, Fla.

[73] Assignee: **Handi Mate, Inc.**, Palm Beach, Fla.

[**] Term: **14 Years**

[21] Appl. No.: **30,762**

[22] Filed: **Nov. 7, 1994**

[52] U.S. Cl. **D6/484; D6/480; D6/485**

[58] Field of Search **D6/480-489, 495; 108/153, 155, 156, 157, 161; 297/440.12; 248/174**

[56] **References Cited**

U.S. PATENT DOCUMENTS

- D. 231,967 7/1974 Webb D6/480
- D. 330,475 10/1992 Bennett D6/485
- D. 352,845 11/1994 Hellwig et al. D6/422

- 3,212,464 10/1965 Steuer 297/440.12 X
- 3,729,244 4/1973 Butler 108/157 X
- 3,837,719 9/1974 Barron 297/440.12 X
- 5,402,738 4/1995 Carr et al. 108/157

Primary Examiner—Janice E. Seeger
Attorney, Agent, or Firm—McHale & Slavin, P.A.

[57] **CLAIM**

The ornamental design for a double corrugated cardboard table, as shown and described.

DESCRIPTION

FIG. 1 is a front view of the double corrugated cardboard table showing the new design, (a rear view, not shown, is a mirror image of said front view); FIG. 2 is a top view thereof; FIG. 3 is a bottom view thereof; FIG. 4 is a left side view; and, FIG. 5 is a right side view.

1 Claim, 2 Drawing Sheets

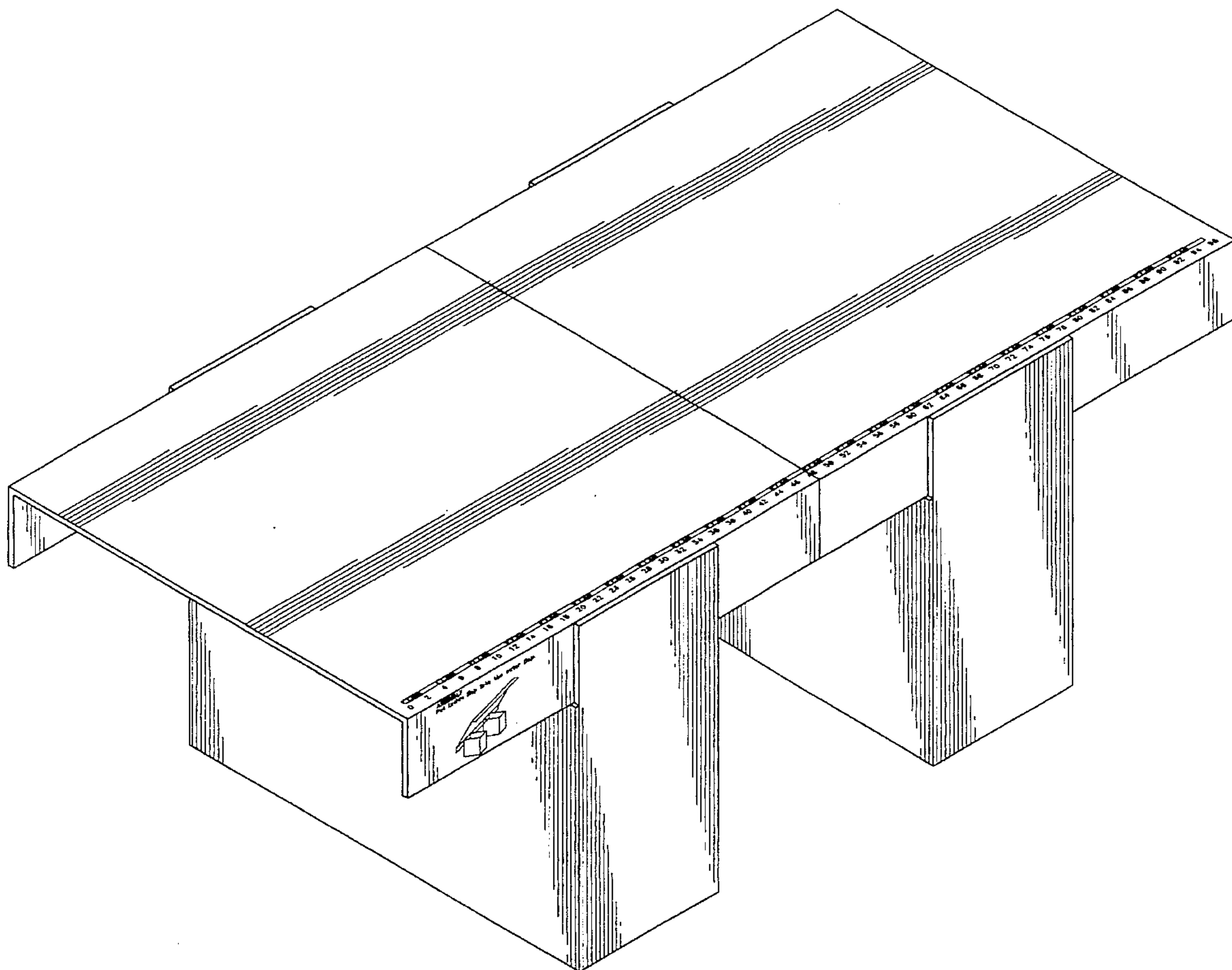

FIG. 1

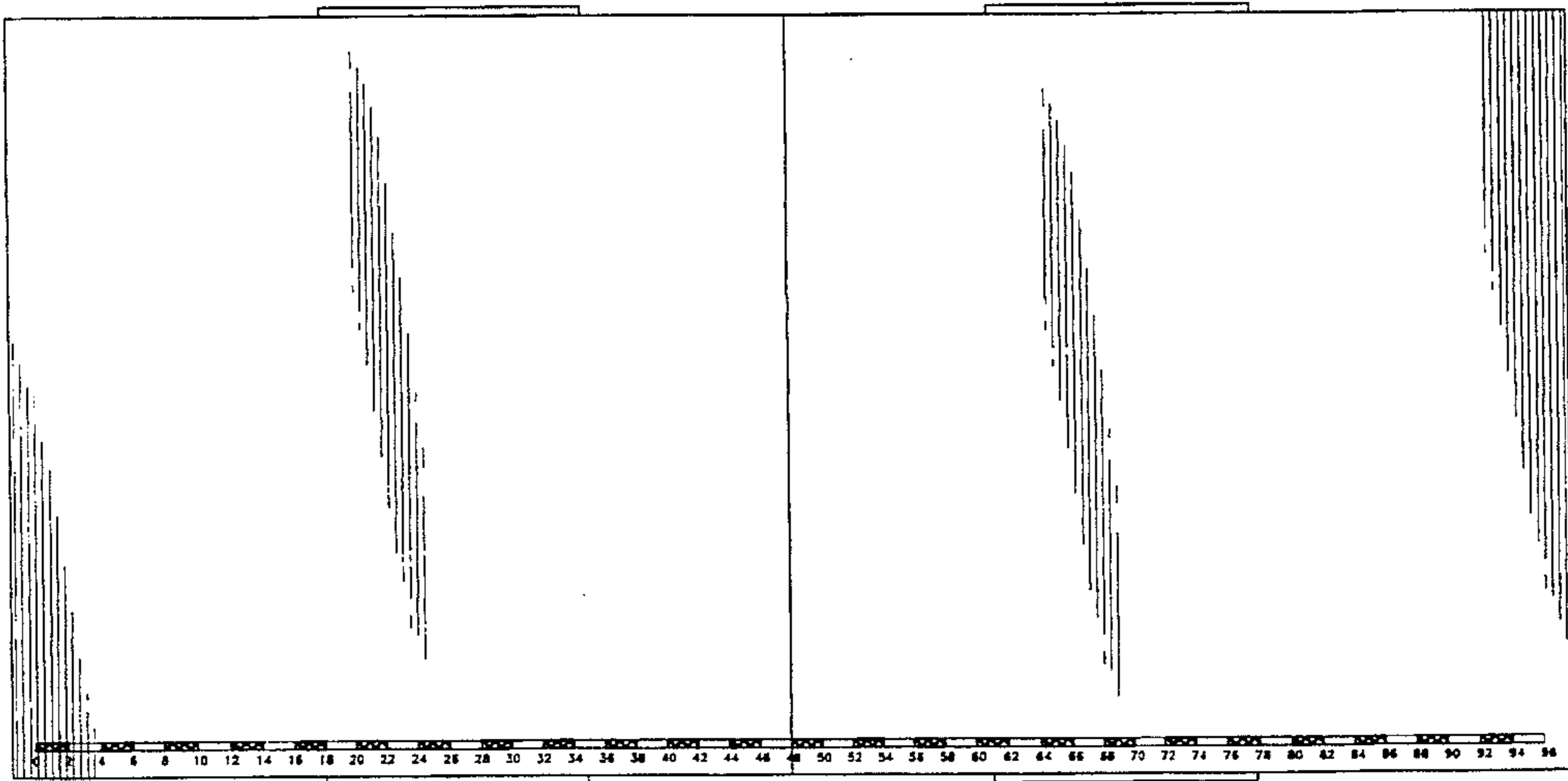

FIG. 2

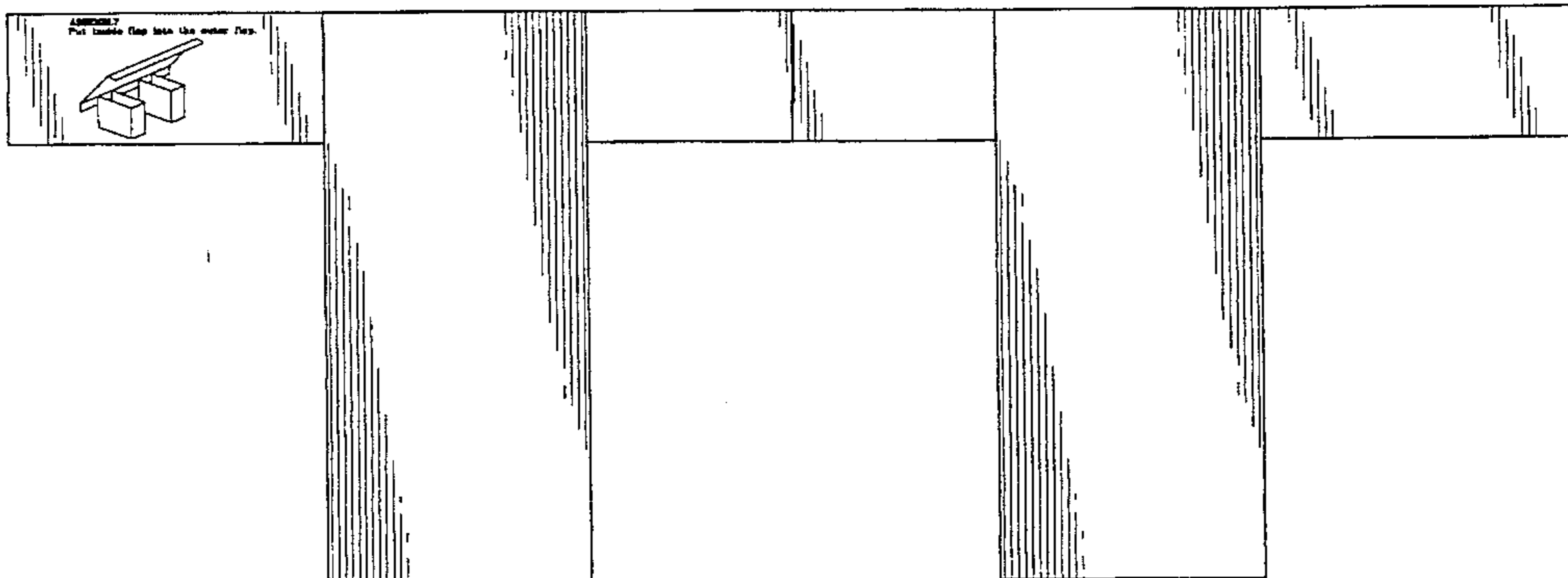

FIG. 3

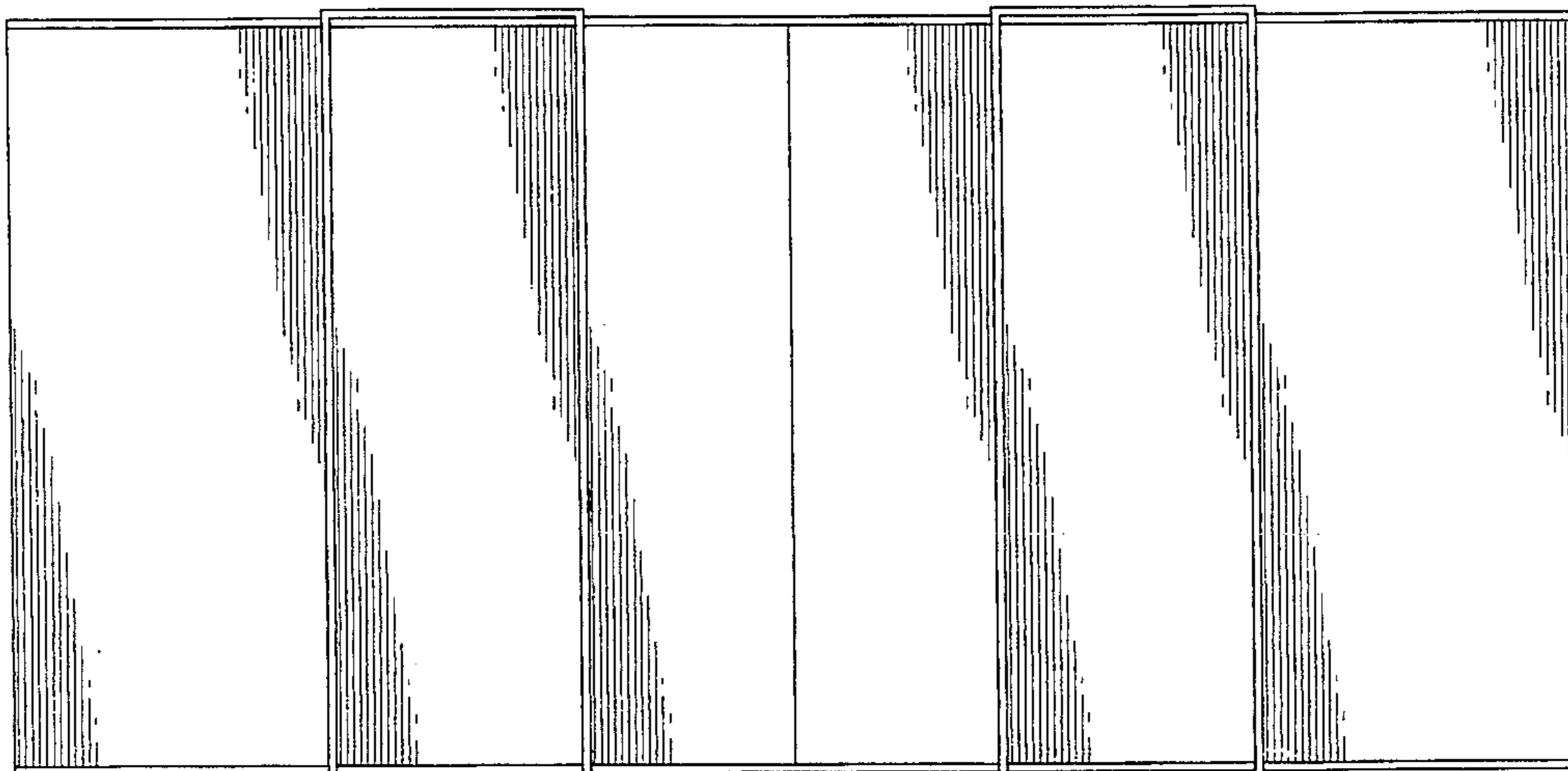

FIG. 4

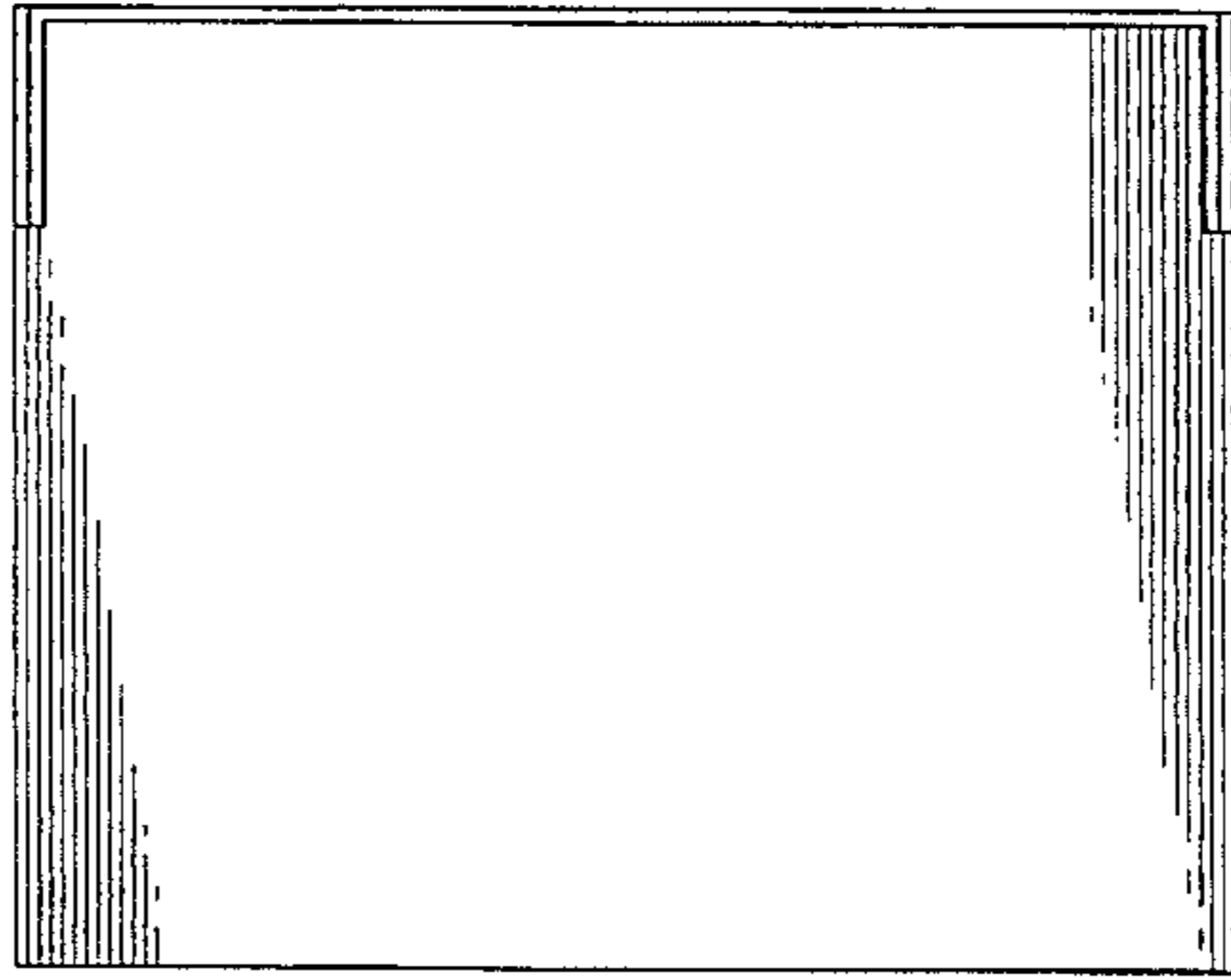

FIG. 5

