



US00D374773S

# United States Patent [19]

[11] **Patent Number: Des. 374,773**

**Domotor**

[45] **Date of Patent: \*\*Oct. 22, 1996**

[54] **WHEELED LUGGAGE CASE**

[75] Inventor: **Agnes C. Domotor**, Providence, R.I.

[73] Assignee: **Samsonite Corporation**, Denver, Colo.

[\*\*] Term: **14 Years**

[21] Appl. No.: **43,264**

[22] Filed: **Aug. 30, 1995**

[52] U.S. Cl. .... **D3/279; D3/276; D3/289**

[58] Field of Search ..... **D3/274, 276, 279, D3/289, 301; 190/18 A, 100, 109, 110, 113, 114, 115**

[56] **References Cited**

**U.S. PATENT DOCUMENTS**

D. 352,395	11/1994	King	.....	D3/279
D. 354,396	1/1995	Lowenstein	.....	D3/279
D. 357,354	4/1995	Marchwiak et al.	.....	D3/276
D. 358,031	5/1995	Aumasson	.....	D3/276
D. 362,548	9/1995	King	.....	D3/279
D. 364,504	11/1995	Bieber et al.	.....	D3/279
4,995,487	2/1991	Plath	.....	190/18 A
5,431,263	7/1995	Nordstrom	.....	190/18 A
5,447,261	9/1995	Mitomi et al.	.....	190/18 A

**OTHER PUBLICATIONS**

Service Merchandise Catalog 1994, p. 363, "Travel Caddy" Totes 15 & 16.

*Primary Examiner*—Ted Shooman

*Assistant Examiner*—Philip Hyder  
*Attorney, Agent, or Firm*—Gregory W. O'Connor

[57] **CLAIM**

The ornamental design for a wheeled luggage case, as shown and described.

**DESCRIPTION**

FIG. 1 is a perspective view taken from the upper lefthand corner of the case embodying my new design;

FIG. 2 is a front view of the case shown in FIG. 1;

FIG. 3 is a back view thereof showing the side opposite that shown in FIG. 2;

FIG. 4 is a left side view thereof;

FIG. 5 is a right side view thereof;

FIG. 6 is a top view thereof; and,

FIG. 7 is a bottom view thereof;

FIG. 8 is a perspective view taken from the upper lefthand corner of a second embodiment of a case embodying my new design;

FIG. 9 is a front view of the case shown in FIG. 8;

FIG. 10 is a top view thereof;

FIG. 11 is a back view thereof showing the side opposite that shown in FIG. 9;

FIG. 12 is a right side view thereof;

FIG. 13 is a left side view thereof; and,

FIG. 14 is a bottom view thereof.

**1 Claim, 6 Drawing Sheets**

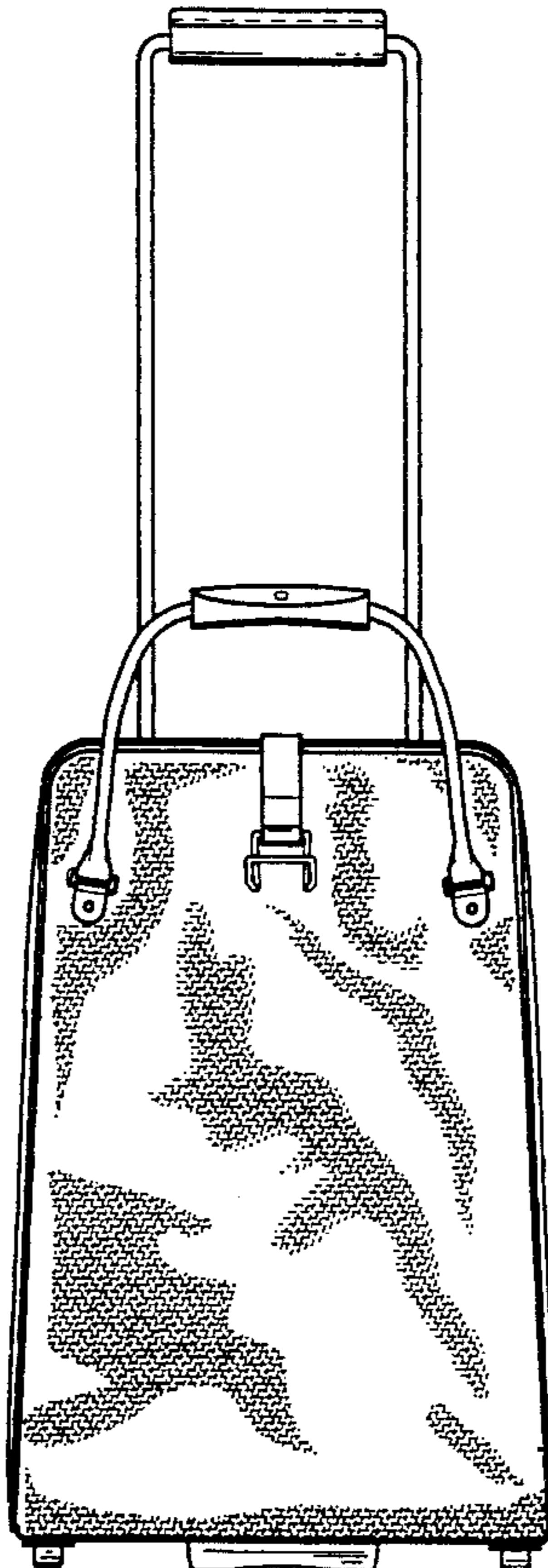

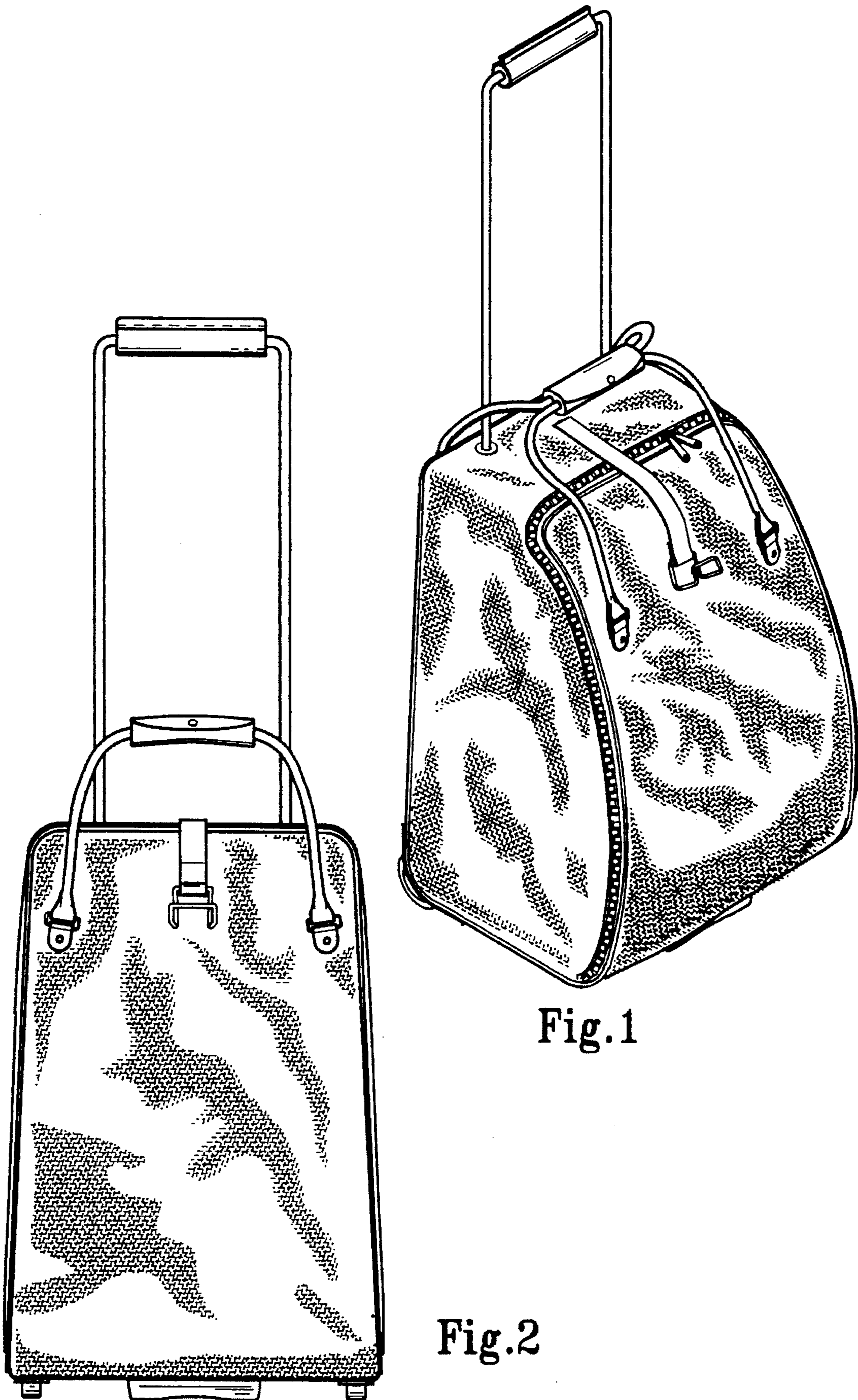

Fig. 1

Fig. 2

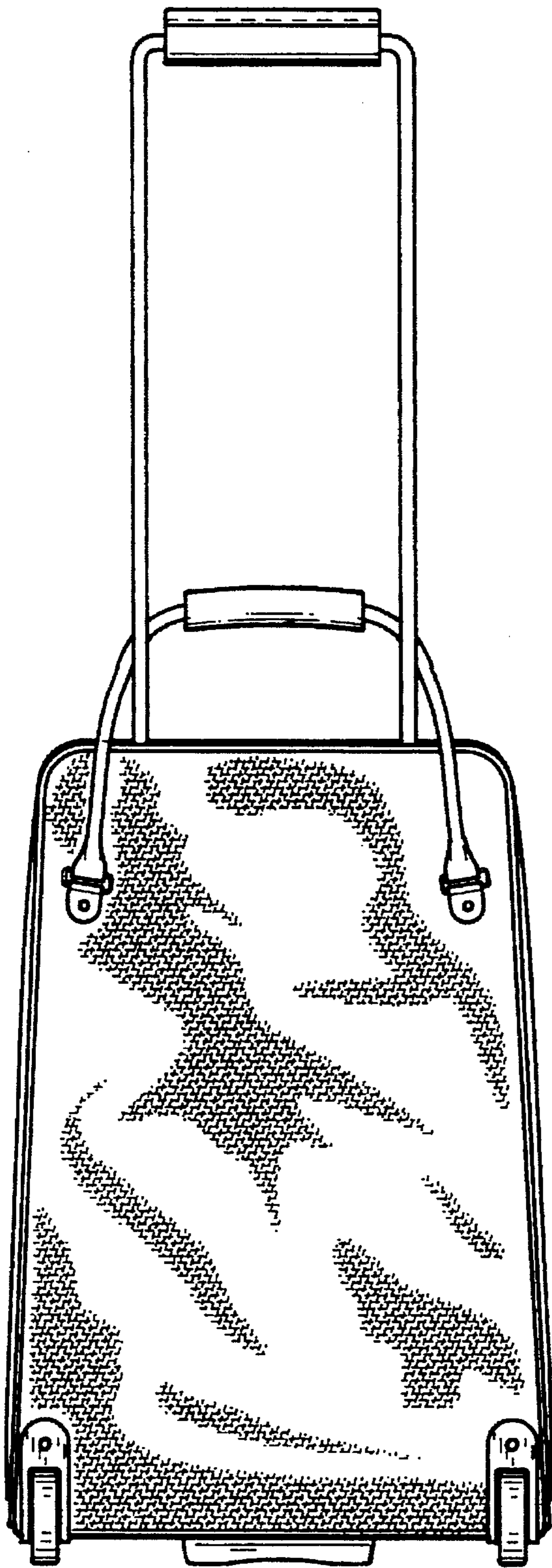

Fig.3

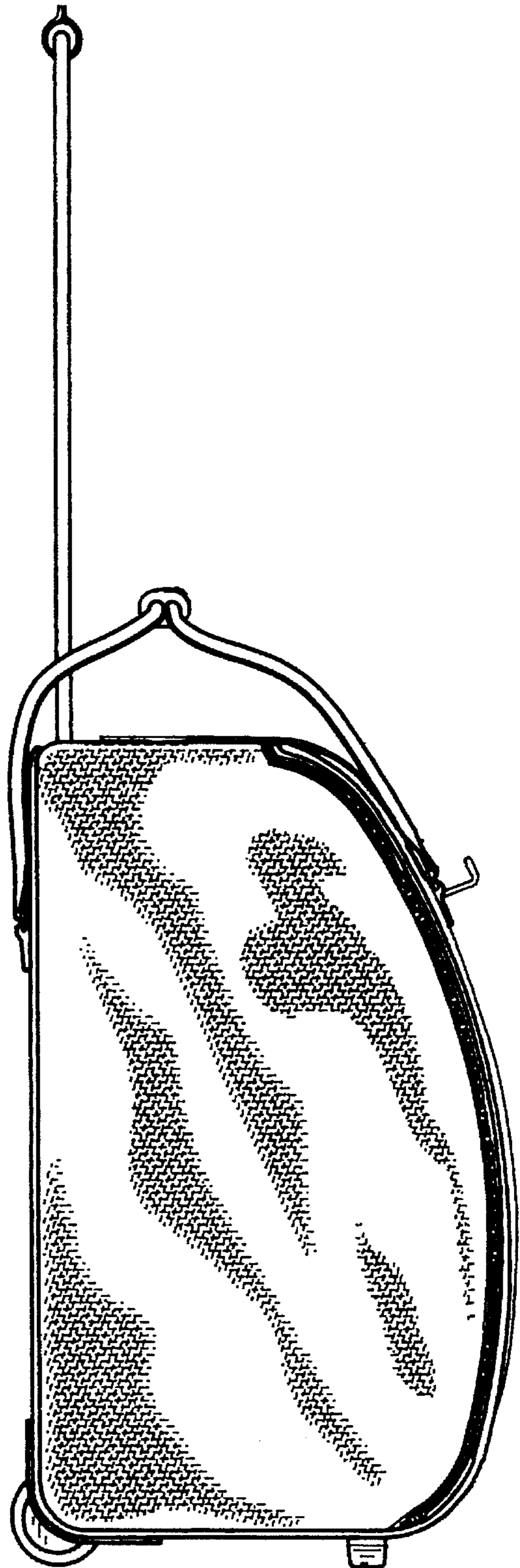

Fig.4

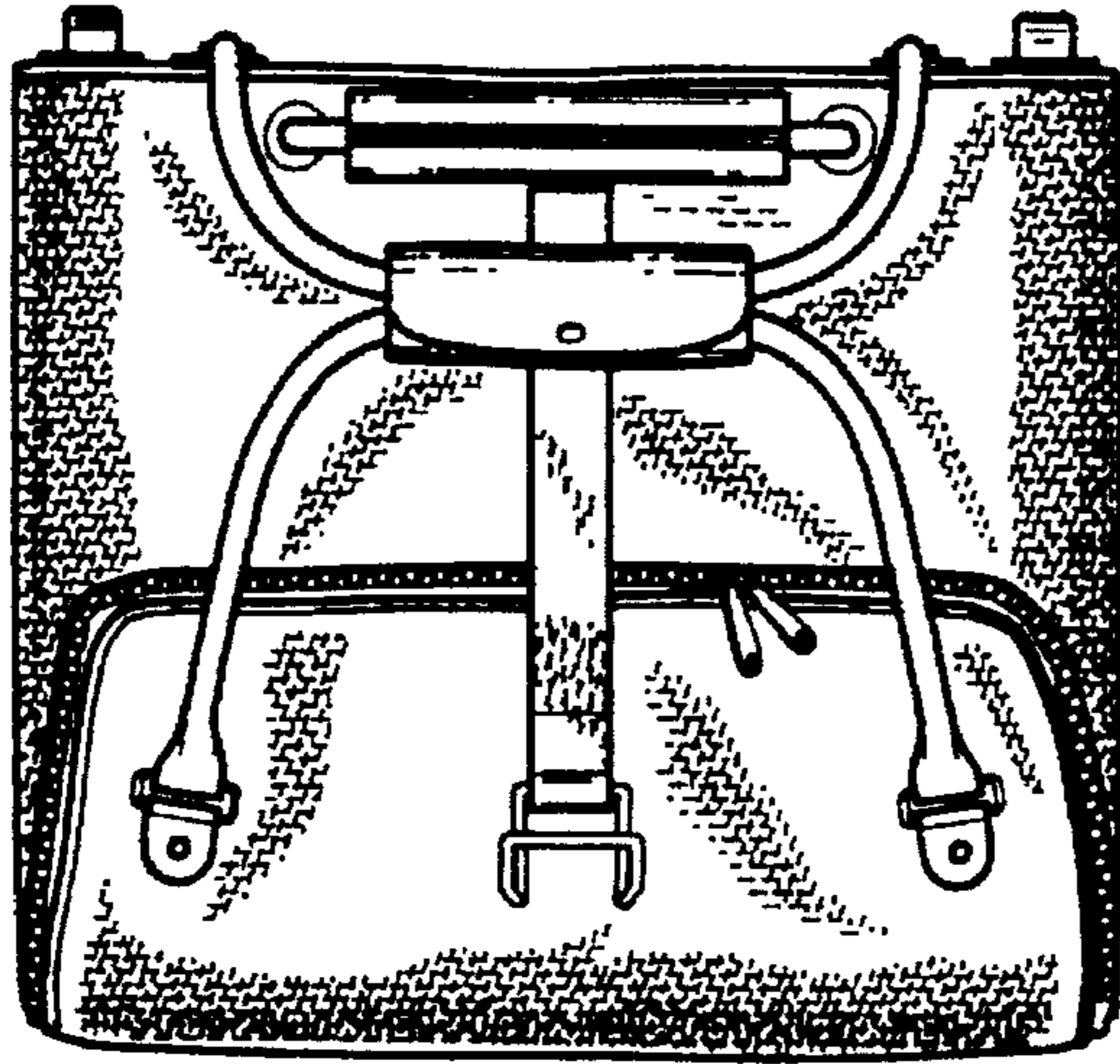

Fig. 6

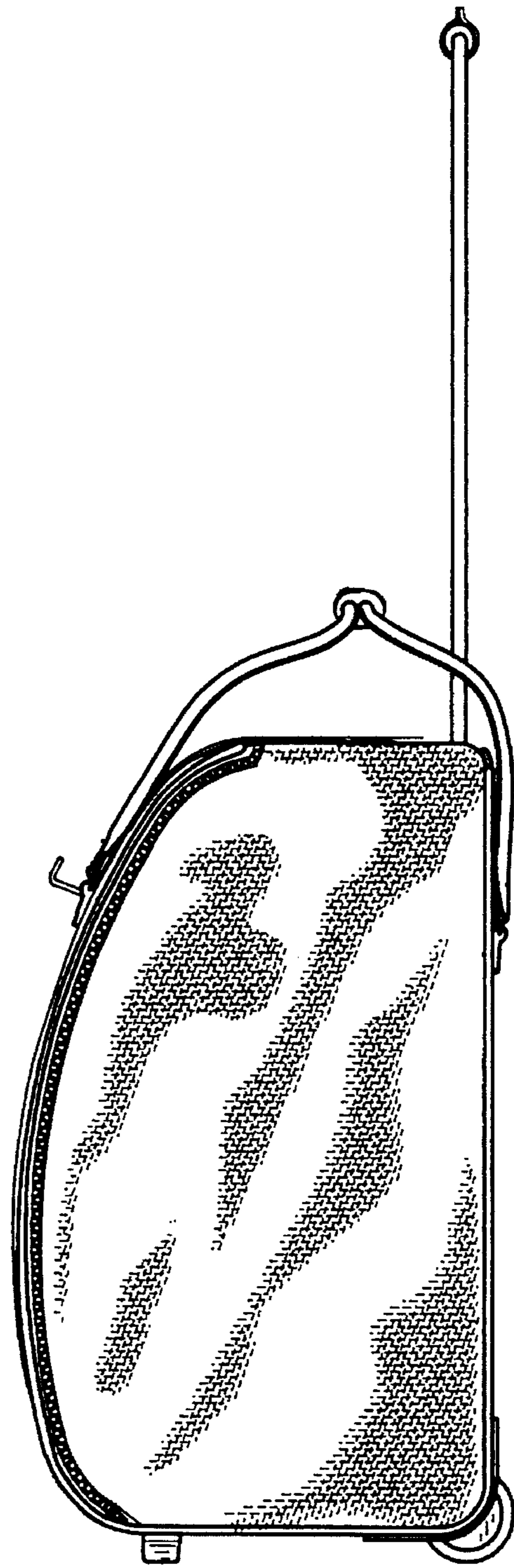

Fig. 5

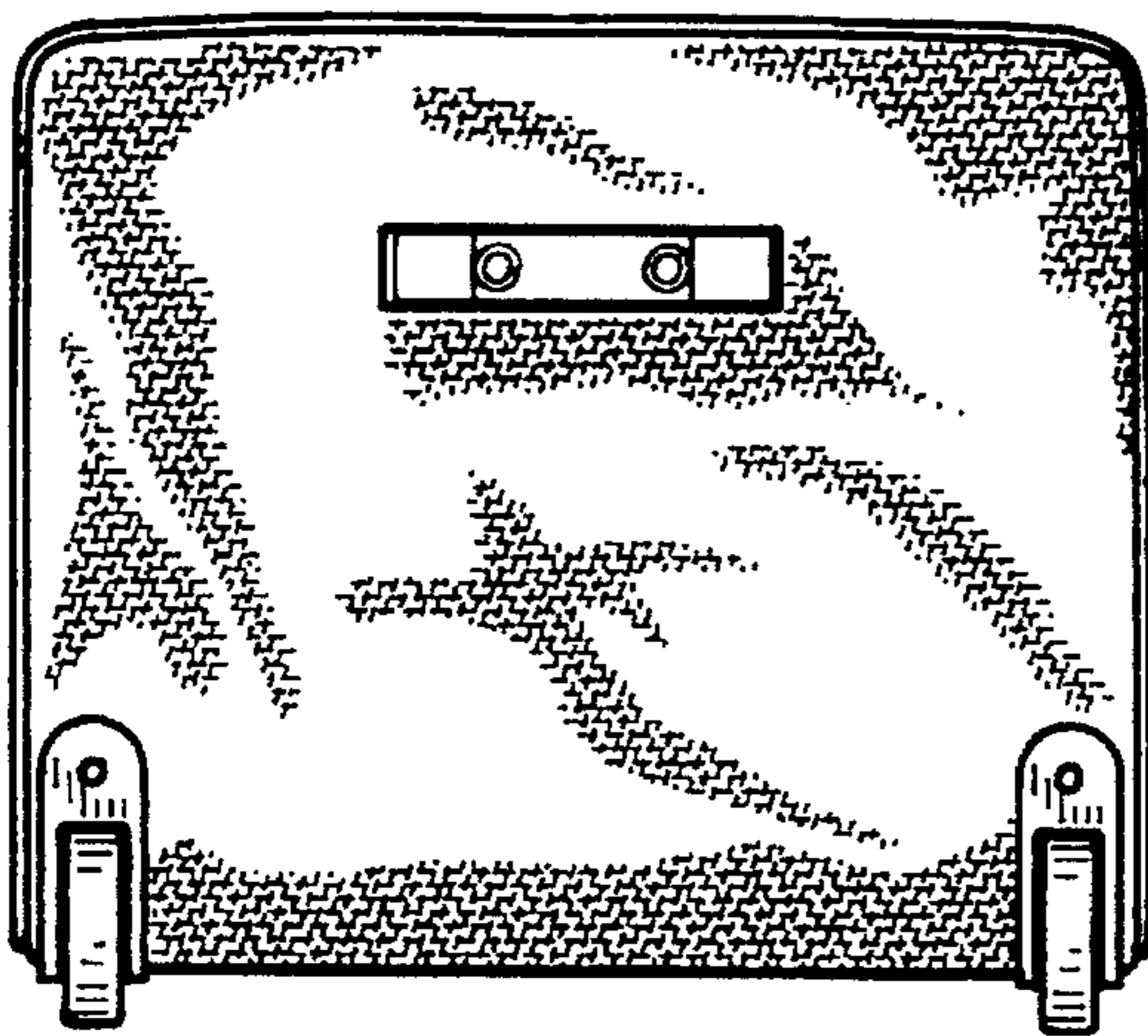

Fig. 7

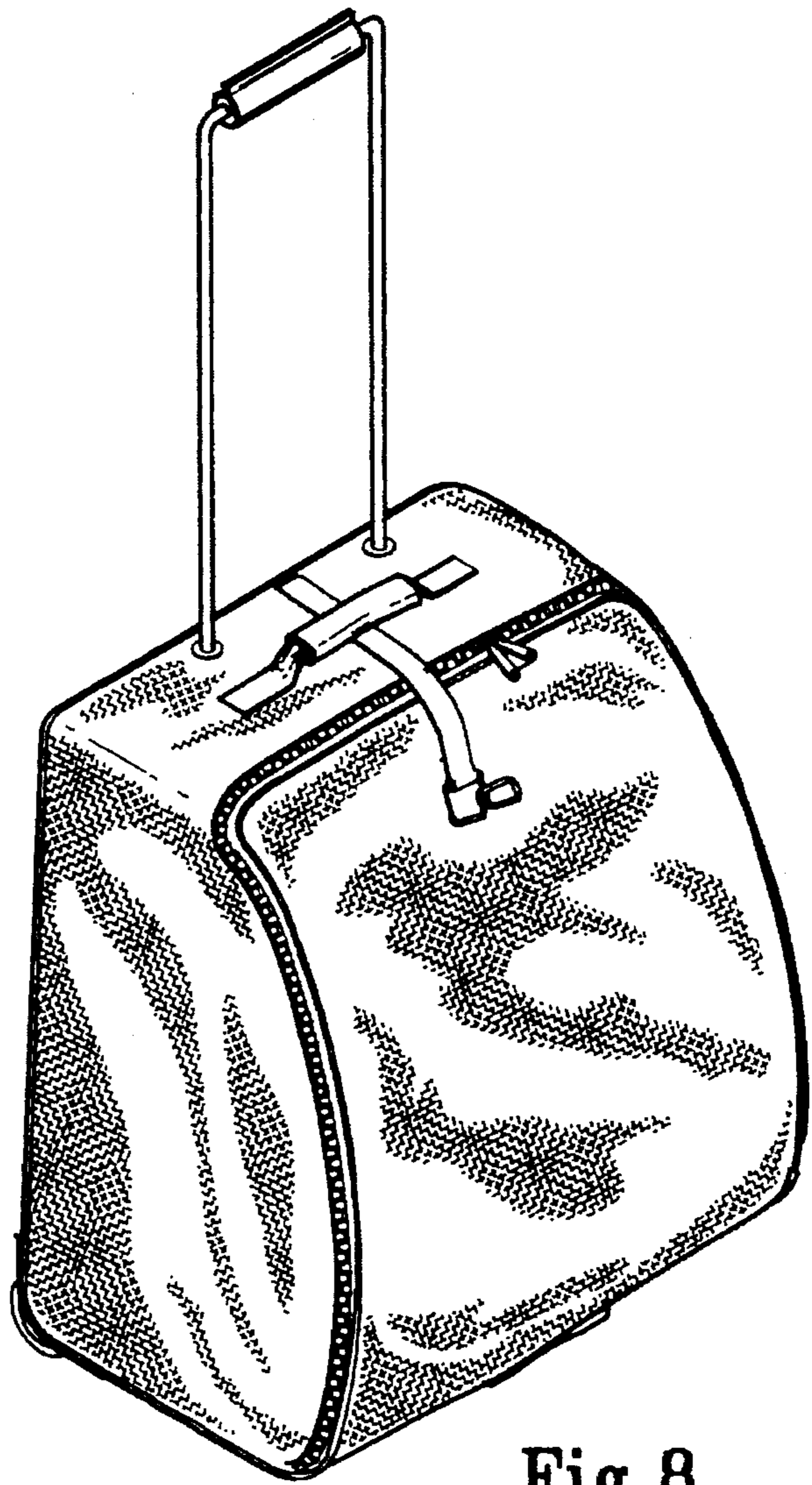

Fig. 8

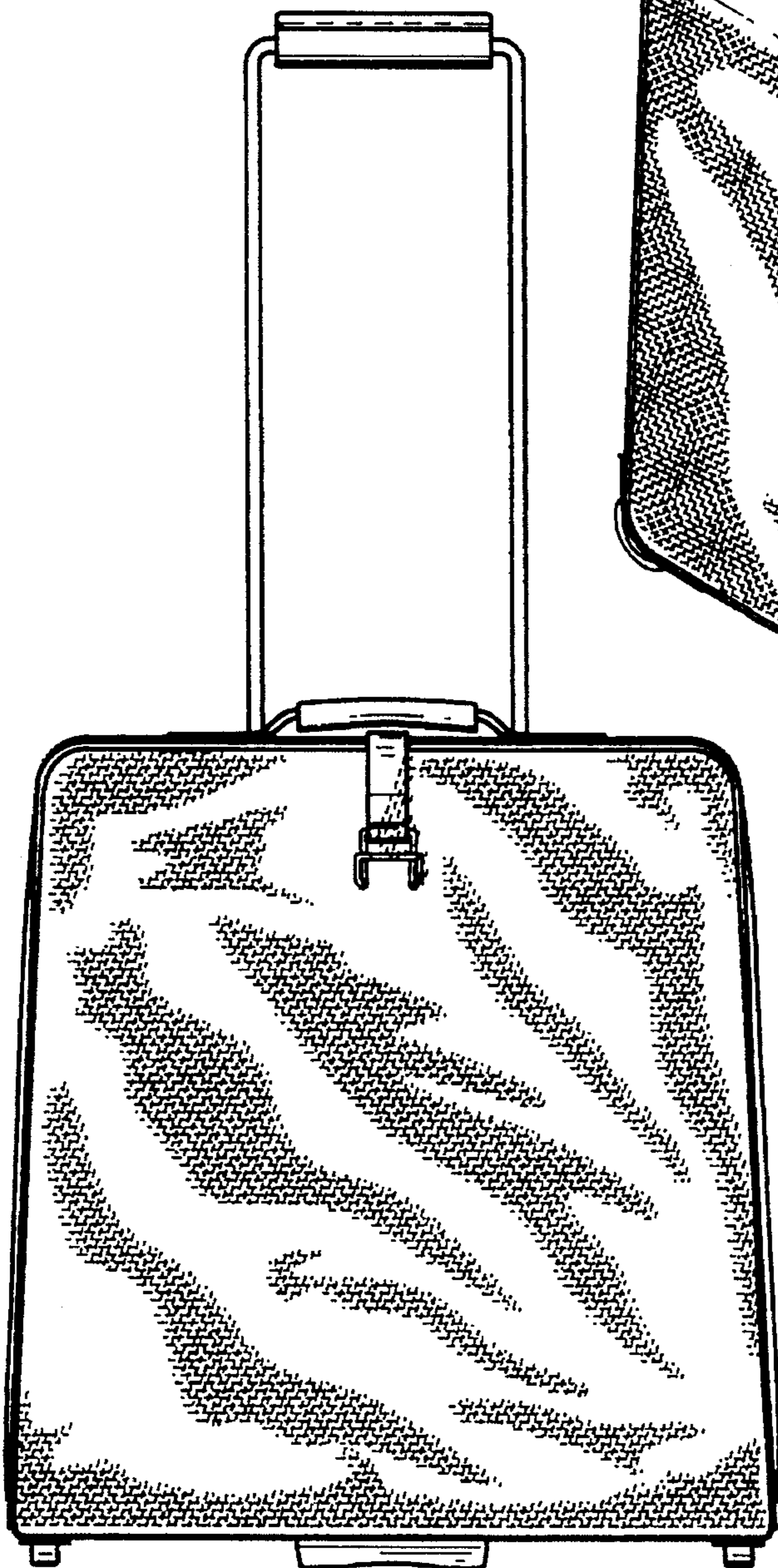

Fig. 9

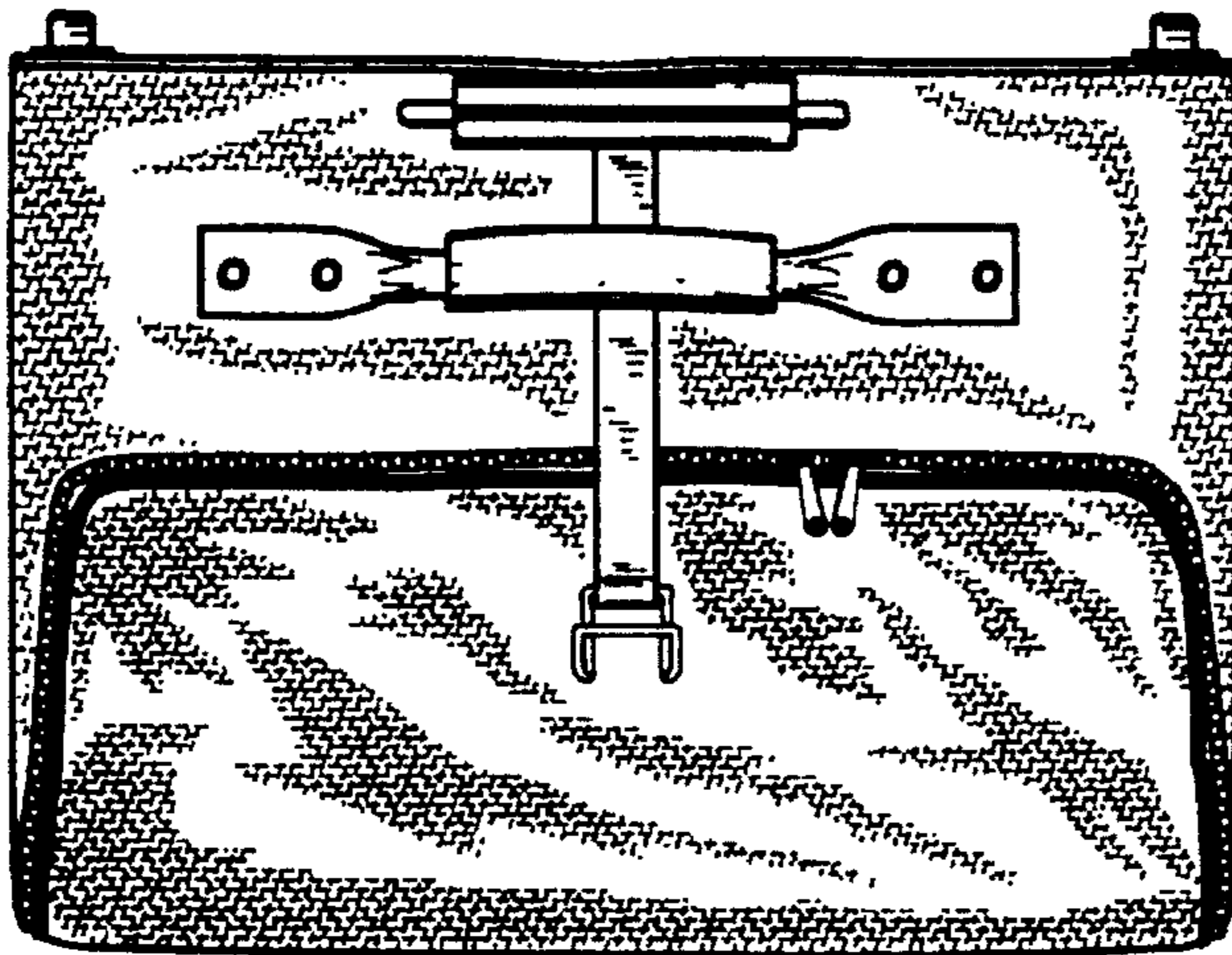

Fig. 10



Fig. 11

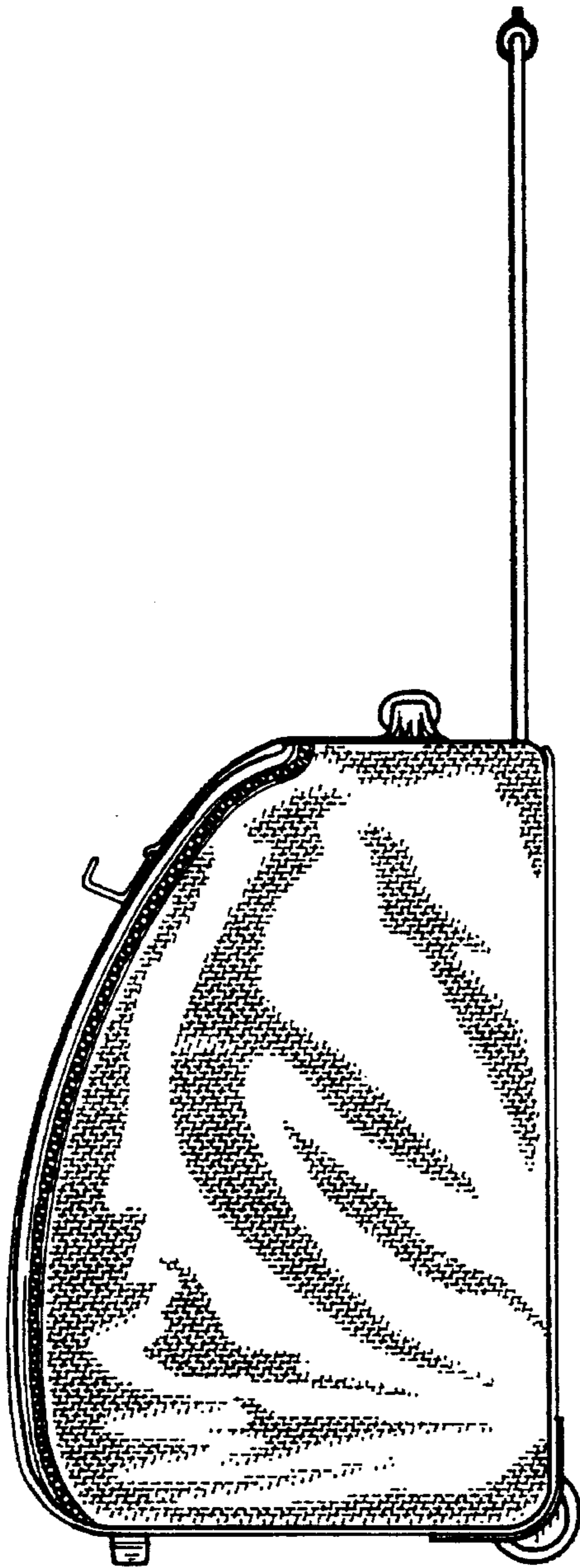

Fig. 12

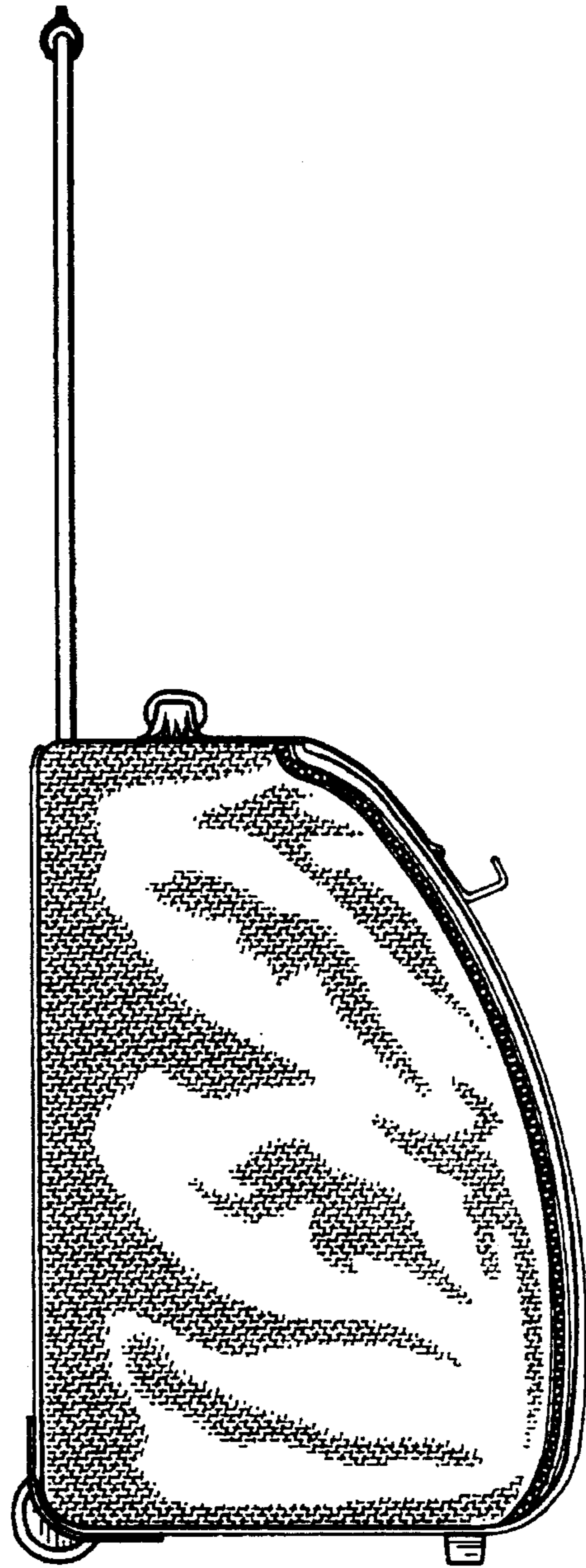

Fig. 13

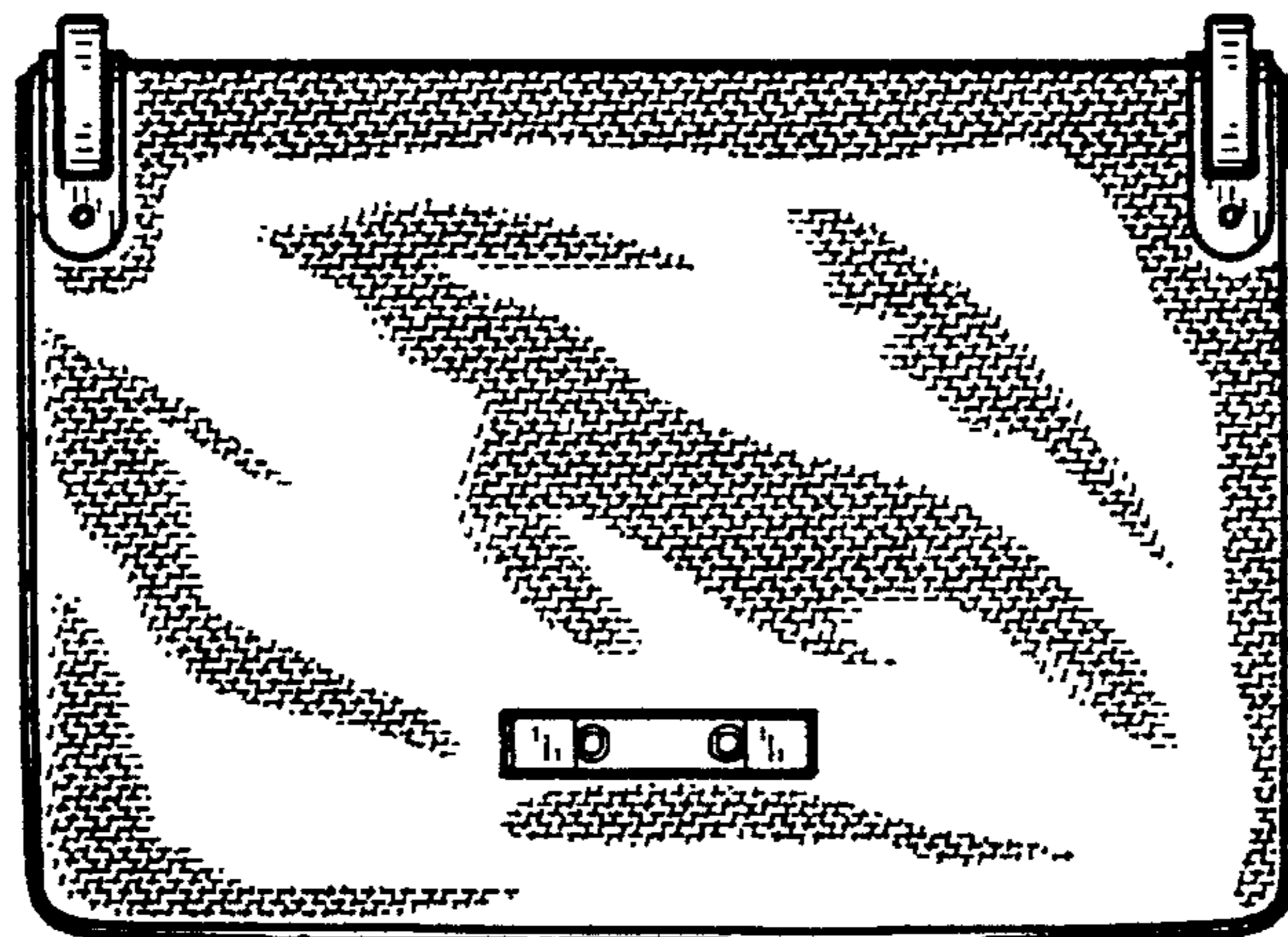

Fig. 14