



US00D374647S

United States Patent [19]
Capra

[11] **Patent Number: Des. 374,647**

[45] **Date of Patent: **Oct. 15, 1996**

[54] **AUTOMOBILE EXHAUST DECOUPLER**

5,308,123 5/1994 Zorn 285/226
5,318,329 6/1994 Suzuki et al. 285/49

[75] Inventor: **Gian L. Capra**, Turin, Italy

FOREIGN PATENT DOCUMENTS

[73] Assignee: **Anamet, Inc.**, Waterbury, Conn.

0217152 11/1991 Italy .

[**] Term: **14 Years**

Primary Examiner—Melody N. Brown
Attorney, Agent, or Firm—Chilton, Alix & Van Kirk

[21] Appl. No.: **21,672**

[57] **CLAIM**

[22] Filed: **Apr. 21, 1994**

[52] **U.S. Cl.** **D12/194**

[58] **Field of Search** D12/194; 285/49,
285/226, 233-235, 257, 286, 405, 414

The ornamental design for an automobile exhaust decoupler, as shown and described.

DESCRIPTION

[56] **References Cited**

FIG. 1 is a side elevational view of the automobile exhaust decoupler showing my new design;
FIG. 2 is a top plan view thereof;
FIG. 3 is an end view thereof; and,
FIG. 4 is a cross-sectional view thereof, taken along the line 4—4 in FIG. 2.

U.S. PATENT DOCUMENTS

D. 220,165	3/1971	Trainor	D12/194
4,659,117	4/1987	Holzhausen et al.	285/49
4,863,200	9/1989	Brandener	285/234
5,145,215	9/1992	Udell	285/49
5,167,430	12/1992	Bainbridge	285/49
5,248,168	9/1993	Chichester et al.	285/49

1 Claim, 2 Drawing Sheets

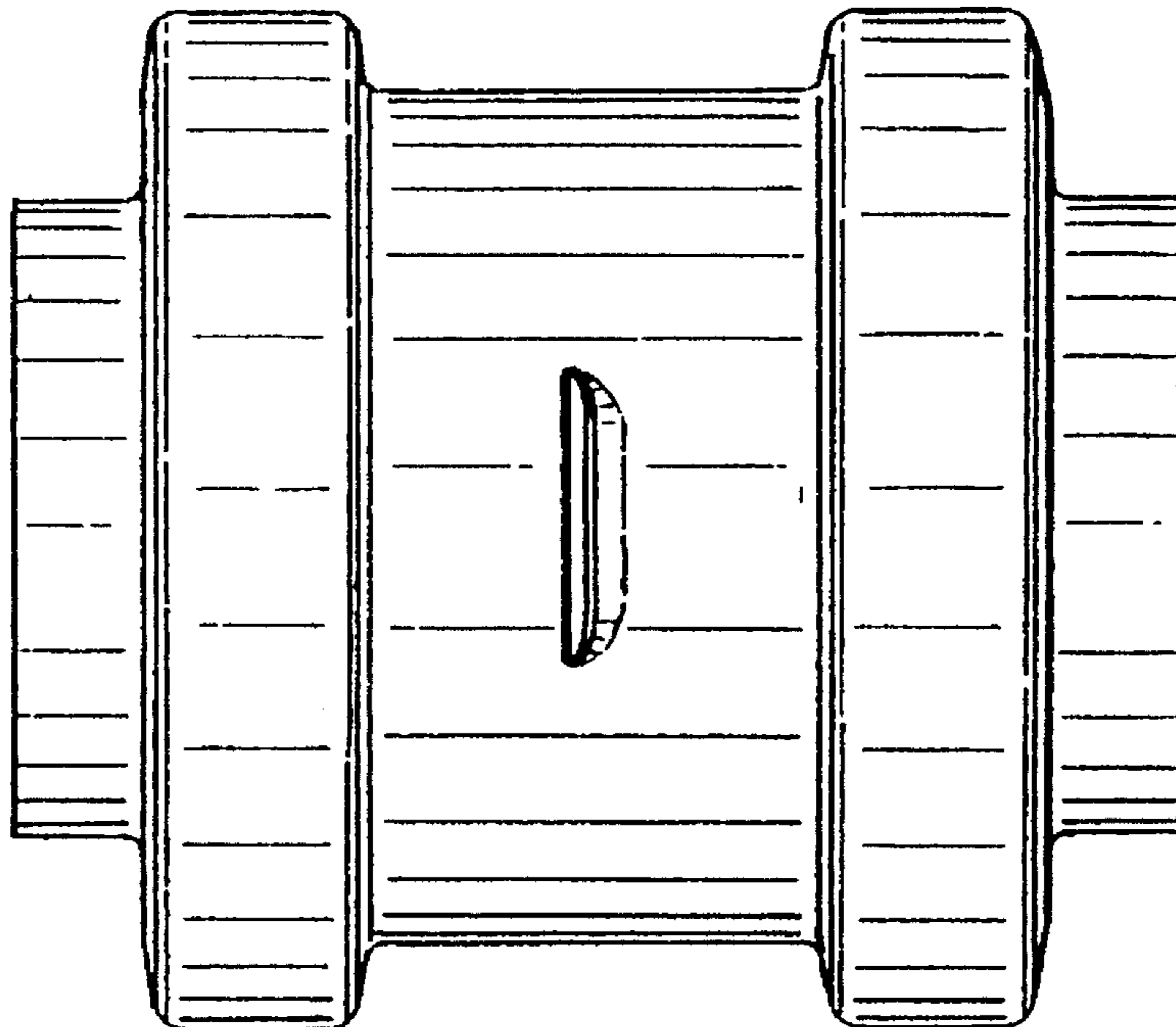

FIG. 1

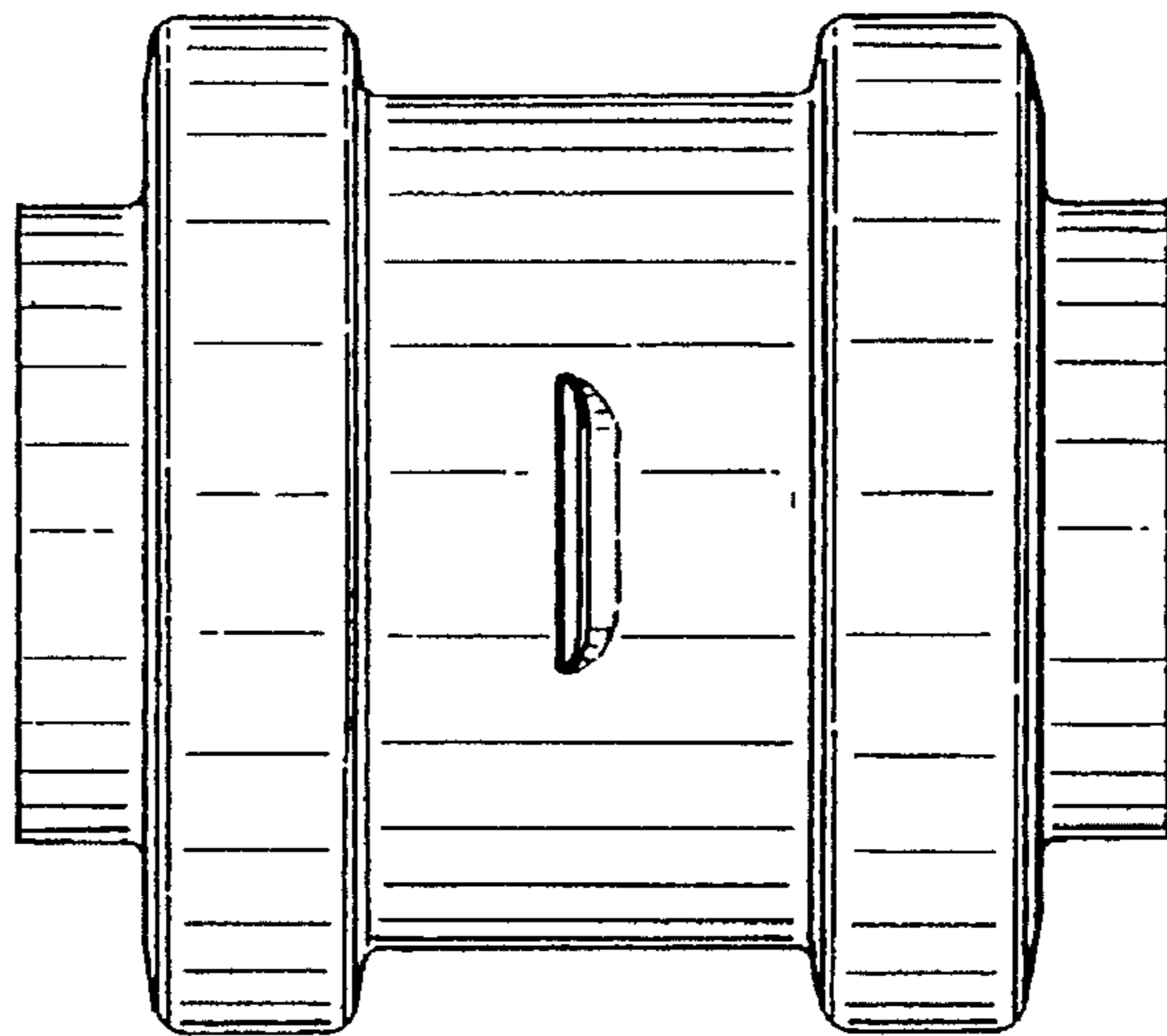

FIG. 2

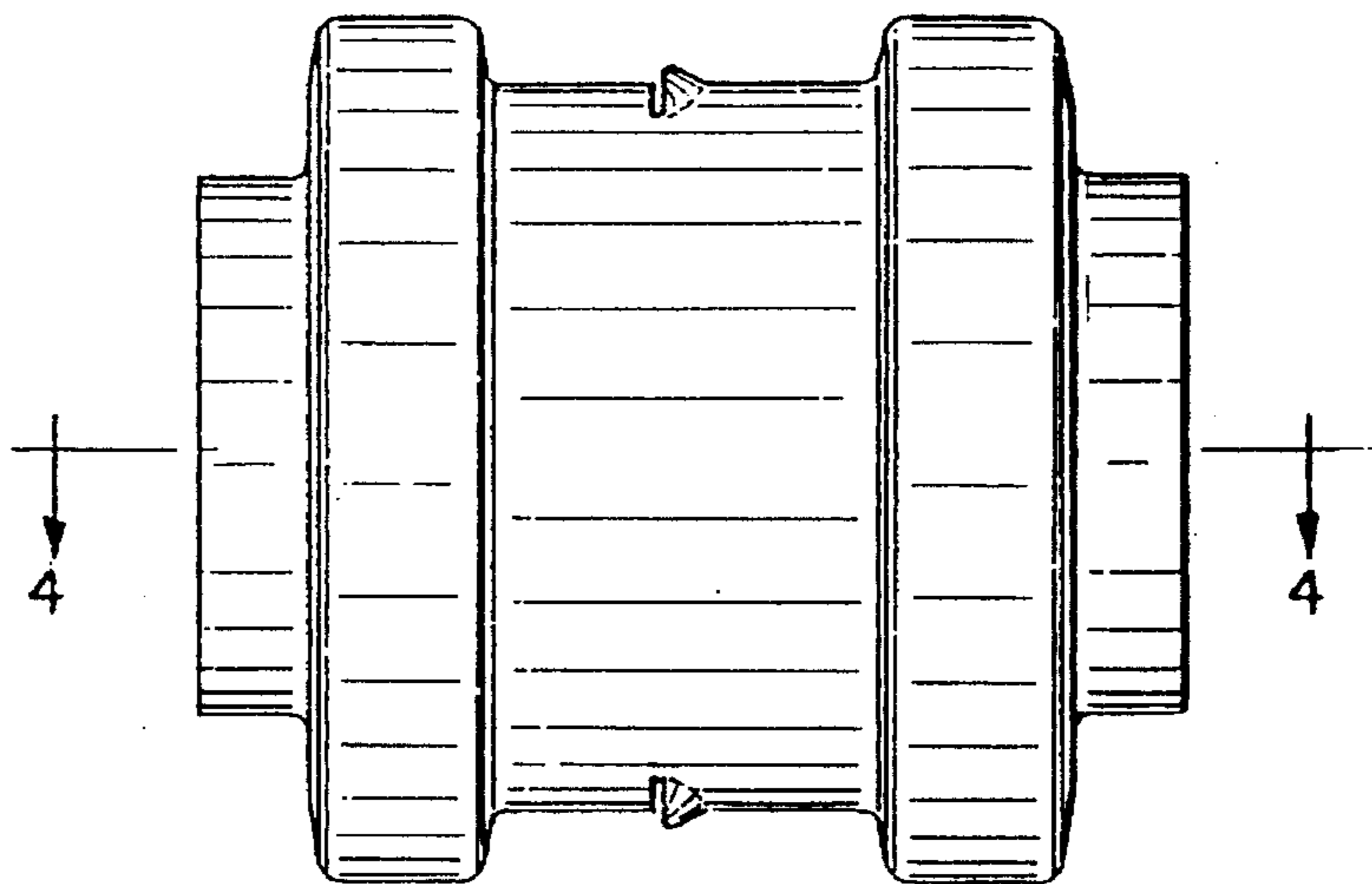
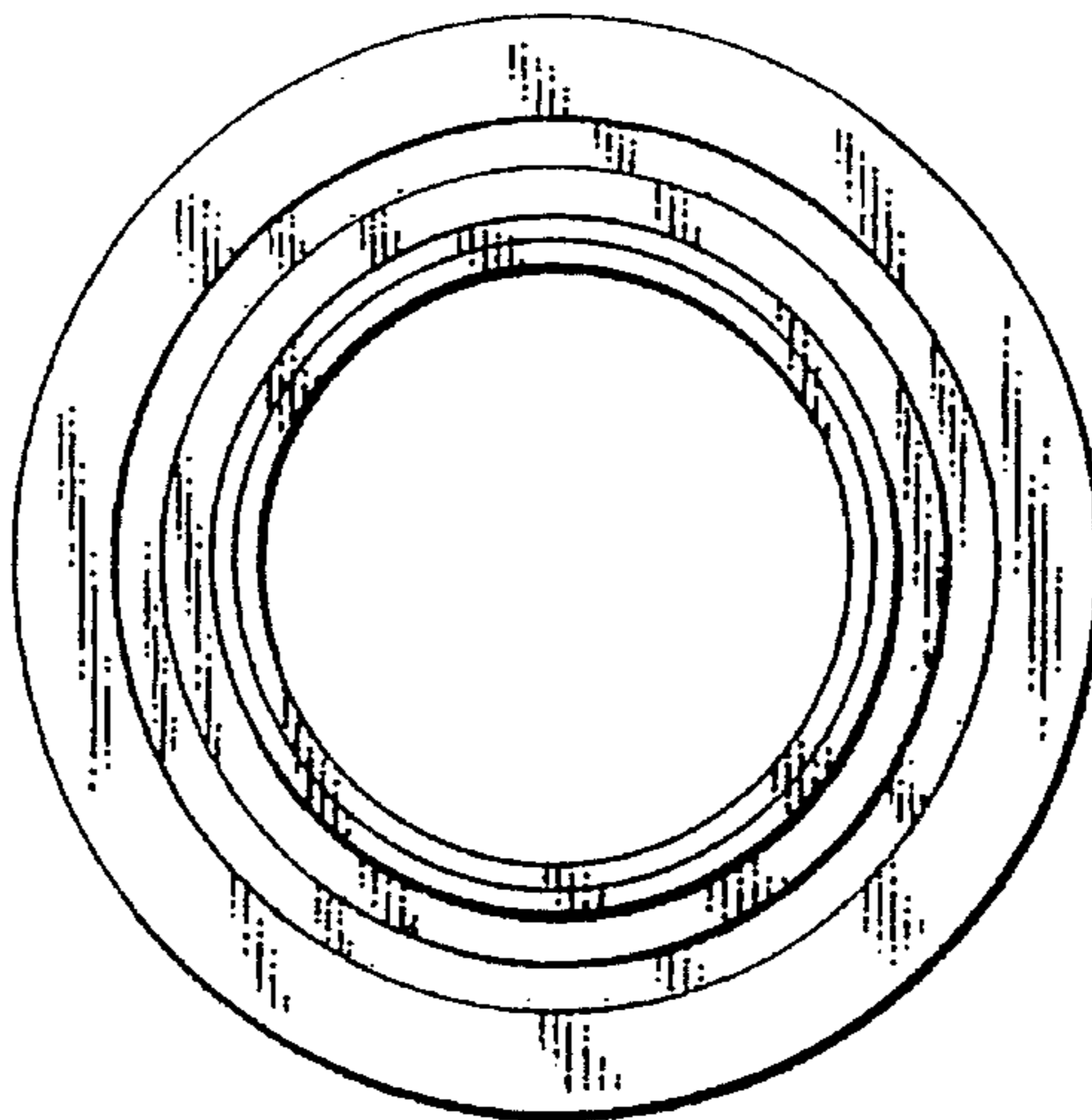

FIG. 3



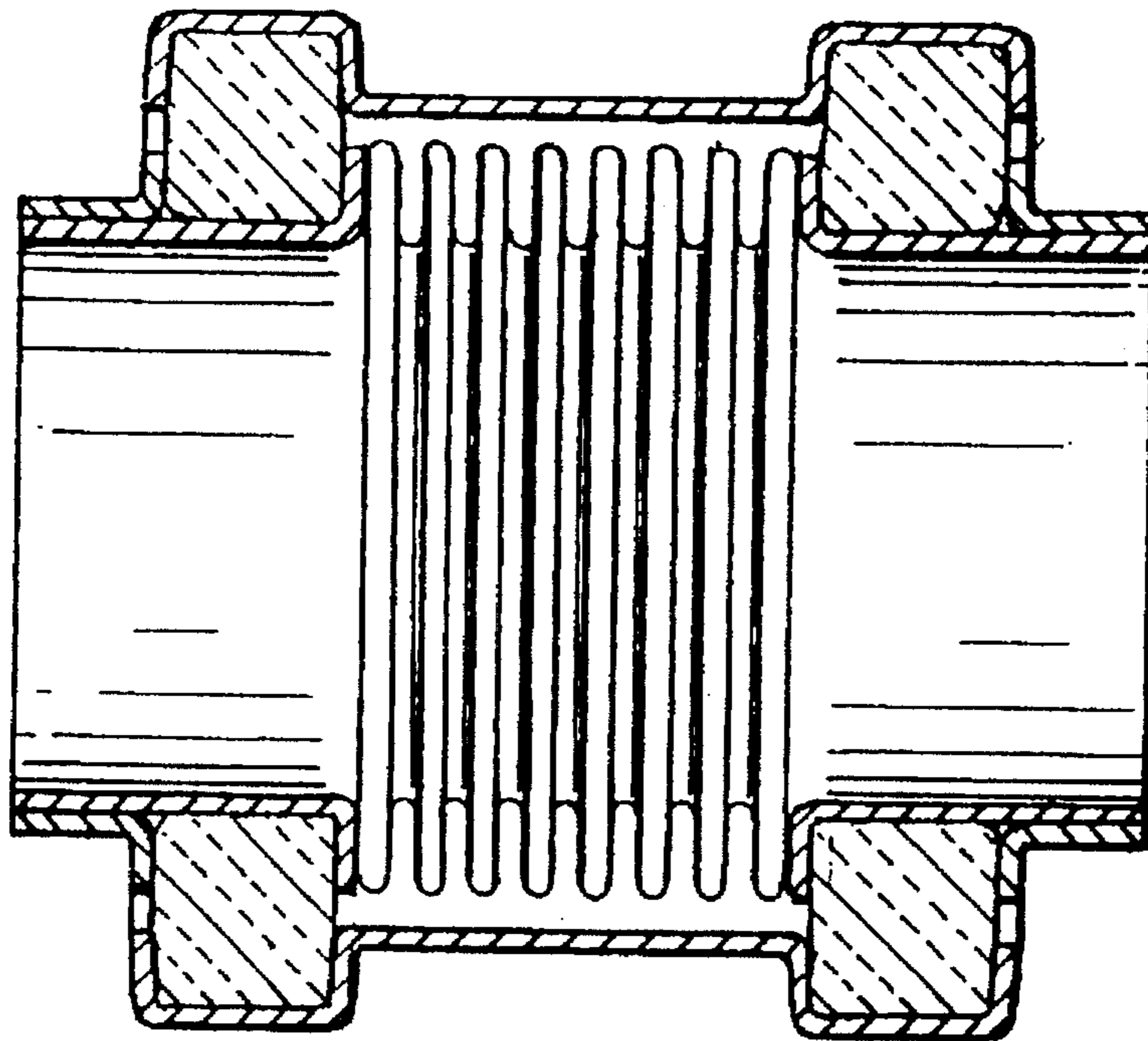

FIG. 4