



US00D374581S

United States Patent [19]

[11] Patent Number: **Des. 374,581**

Kiniry

[45] Date of Patent: ****Oct. 15, 1996**

[54] **HAND RAIL FOR RECREATIONAL VEHICLE**

[76] Inventor: **Sam Kiniry**, 2119 E. Lorita Way, Sandy, Utah 84093

[**] Term: **14 Years**

3,154,344	10/1964	Stableford	297/417
3,993,350	11/1976	McFarlane	297/417
4,029,352	6/1977	Evans	296/24.1
4,040,665	8/1977	Wallace et al.	297/417
4,261,550	4/1981	Gregory	256/67
5,024,420	6/1991	Downing	256/67
5,116,025	5/1992	Kiniry	259/67

[21] Appl. No.: **47,705**

[22] Filed: **Dec. 11, 1995**

[52] U.S. Cl. **D6/501; D12/421**

[58] Field of Search D12/421, 419, D12/420; D6/491, 501, 500; 256/58, 67; 296/37.15; 297/411.1, 411.2, 417

[56] **References Cited**

U.S. PATENT DOCUMENTS

D. 194,460	1/1963	Kategiams	D6/501
D. 288,158	2/1987	Dunnington	D6/491
D. 296,094	6/1988	Sheek	D12/421
D. 315,131	3/1991	Thurman	D12/421
D. 343,537	1/1994	Harde	D6/501
D. 345,648	4/1994	Favilla	D12/421
3,116,093	12/1963	Bosack	297/417

Primary Examiner—Melody N. Brown
Attorney, Agent, or Firm—Thorpe, North & Western

[57] **CLAIM**

The ornamental design for a hand rail for recreational vehicle, as shown and described.

DESCRIPTION

FIG. 1 is a perspective view of a hand rail for recreational vehicle showing my new design;
FIG. 2 is a bottom view;
FIG. 3 is a top view;
FIG. 4 is a side view;
FIG. 5 is a front end view; and,
FIG. 6 is a back end view.

1 Claim, 4 Drawing Sheets

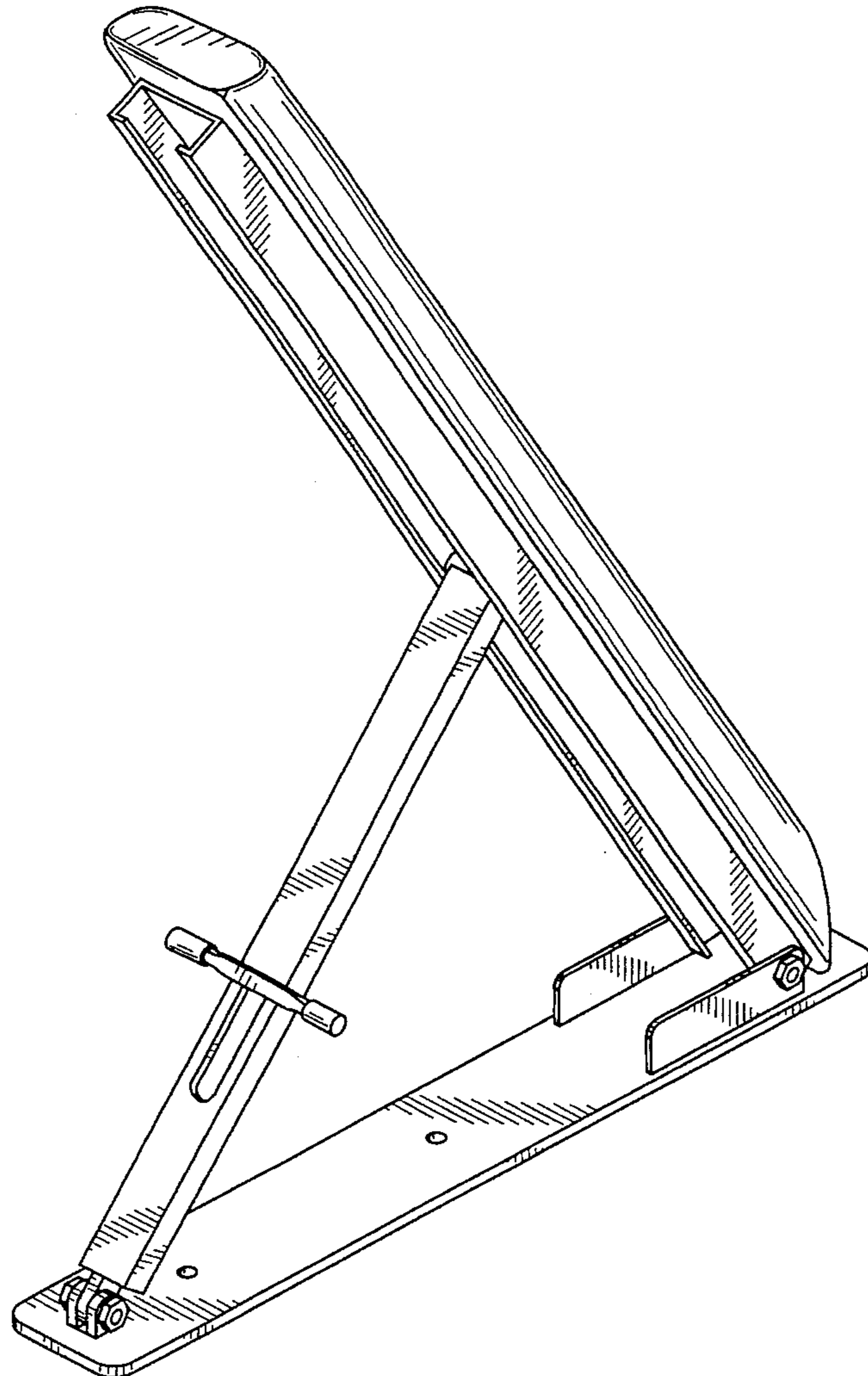

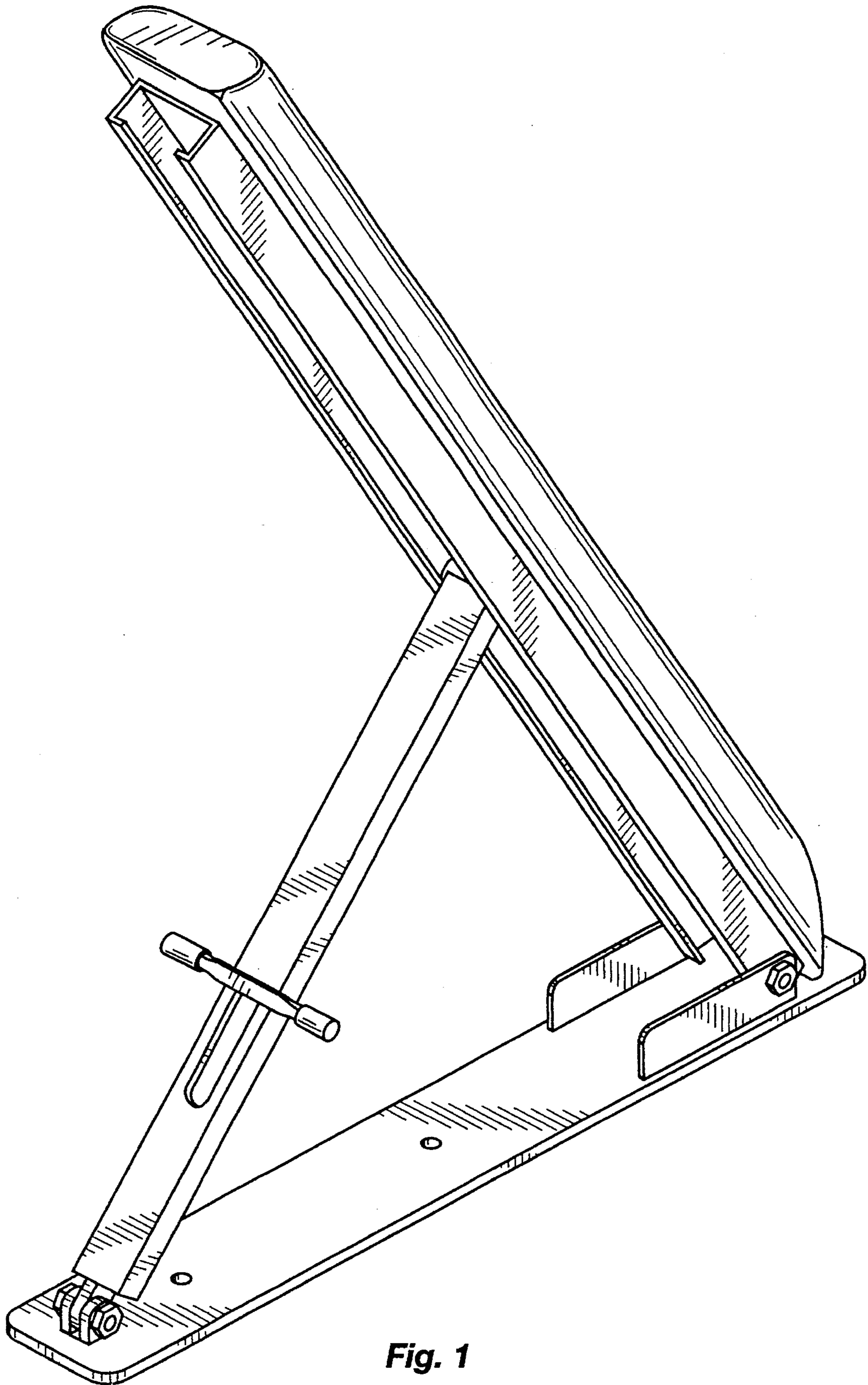

Fig. 1

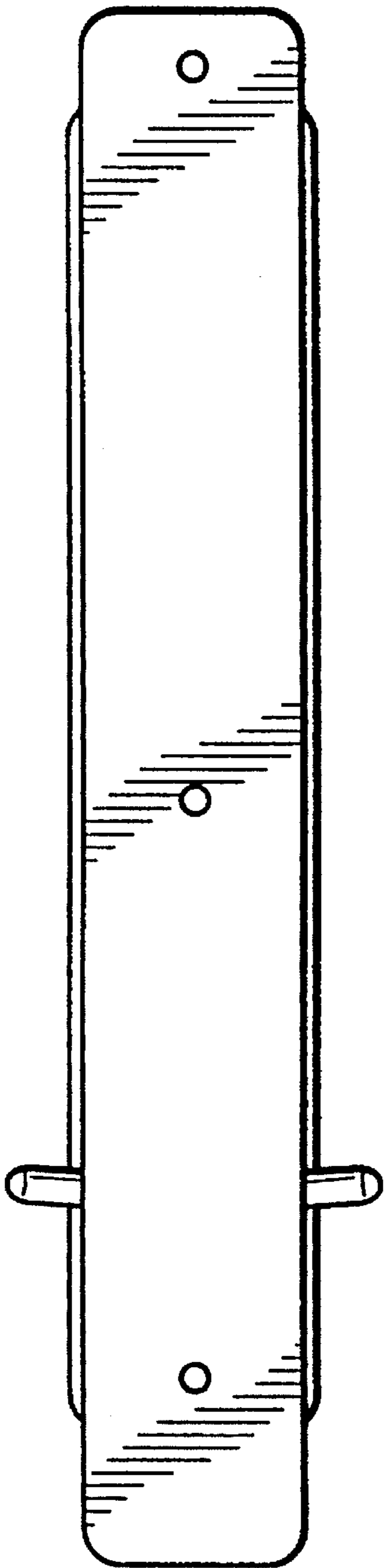

Fig. 2

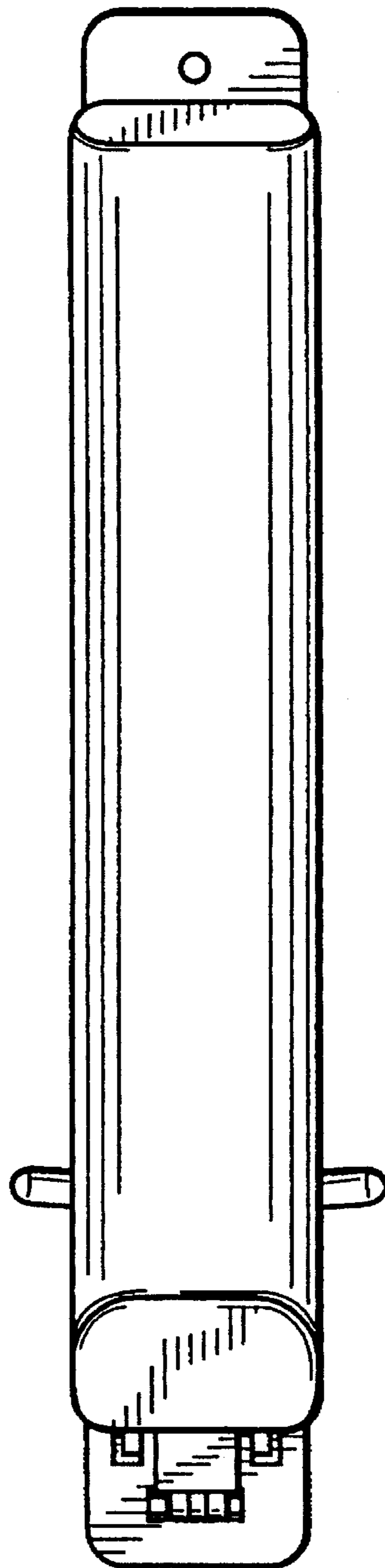

Fig. 3

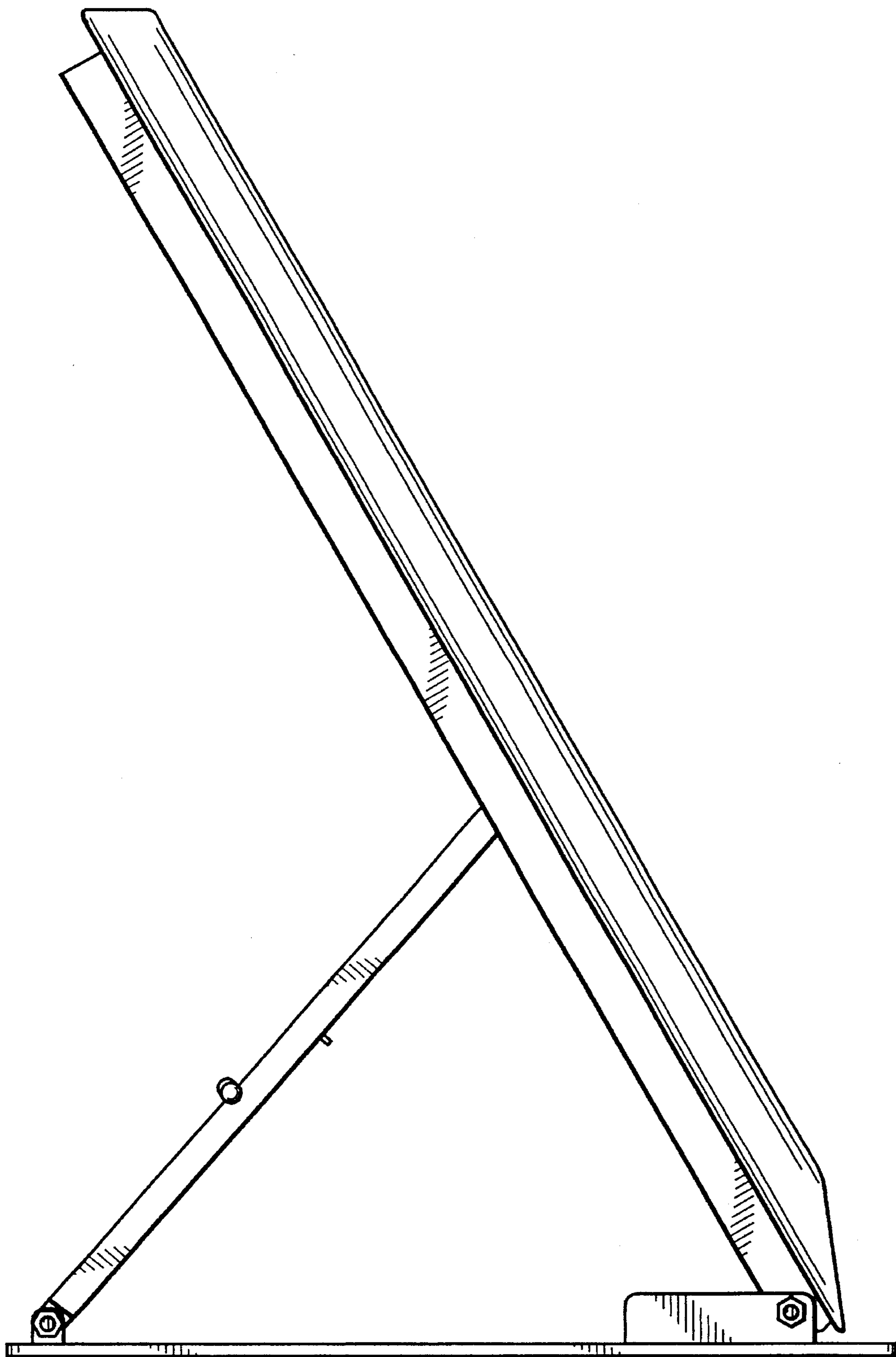

Fig. 4

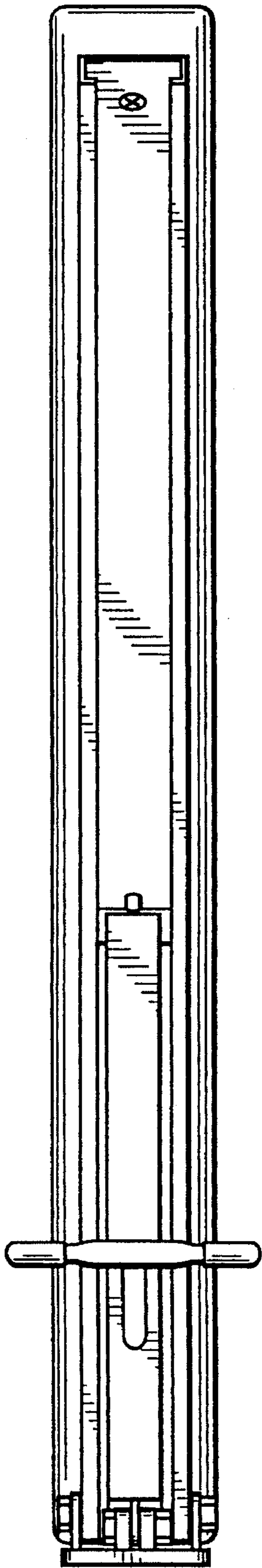

Fig. 5

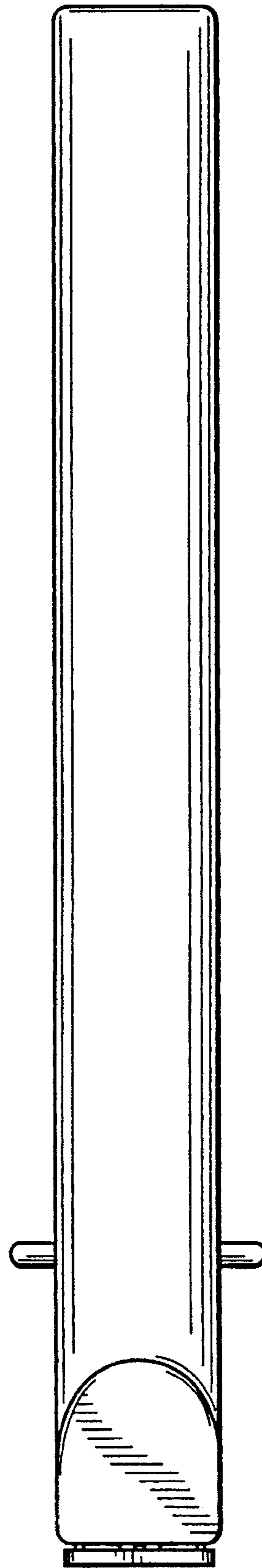

Fig. 6