



US00D374415S

United States Patent [19]
Thomson

[11] **Patent Number: Des. 374,415**
[45] **Date of Patent: **Oct. 8, 1996**

[54] **VEHICLE**

[75] Inventor: **George D. Thomson**, Coventry, United Kingdom

[73] Assignee: **Rover Group Limited**, Birmingham, England

[**] Term: **14 Years**

[21] Appl. No.: **33,778**

[22] Filed: **Jan. 20, 1995**

[30] **Foreign Application Priority Data**

Jul. 28, 1994 [GB] United Kingdom 2040624
Jul. 28, 1994 [GB] United Kingdom 2040625

[52] **U.S. Cl.** **D12/91**

[58] **Field of Search** D12/91; 296/185

[56] **References Cited**

U.S. PATENT DOCUMENTS

D. 350,504 9/1994 Nixon D12/91

OTHER PUBLICATIONS

Motor Trend, Oct. 1993, p. 93, Range Rover County LWB, center of page.

Motor Trend, May 1994, p. 19, Land Rover Discovery SUV, bottom right side of page.

Motor Trend, Apr. 1994, pp. 90 & 91, Mitsubishi Montero SR.

Autocar & Motor, Feb. 9, 1994, pp. 6 & 7, Range Rover "Pegasus".

Primary Examiner—James M. Gandy
Attorney, Agent, or Firm—Davis, Bujold & Streck, P.A.

[57] **CLAIM**

The ornamental design for a motor vehicle and a toy vehicle, as shown.

DESCRIPTION

FIG. 1 is a front perspective view of a vehicle;
FIG. 2 is a rear perspective view of the vehicle of FIG. 1;
FIG. 3 is a front view of the vehicle of FIG. 1;
FIG. 4 is a rear view of the vehicle of FIG. 1;
FIG. 5 is a plan view of the vehicle of FIG. 1; and,
FIG. 6 is a side view of the vehicle of FIG. 1.

1 Claim, 5 Drawing Sheets

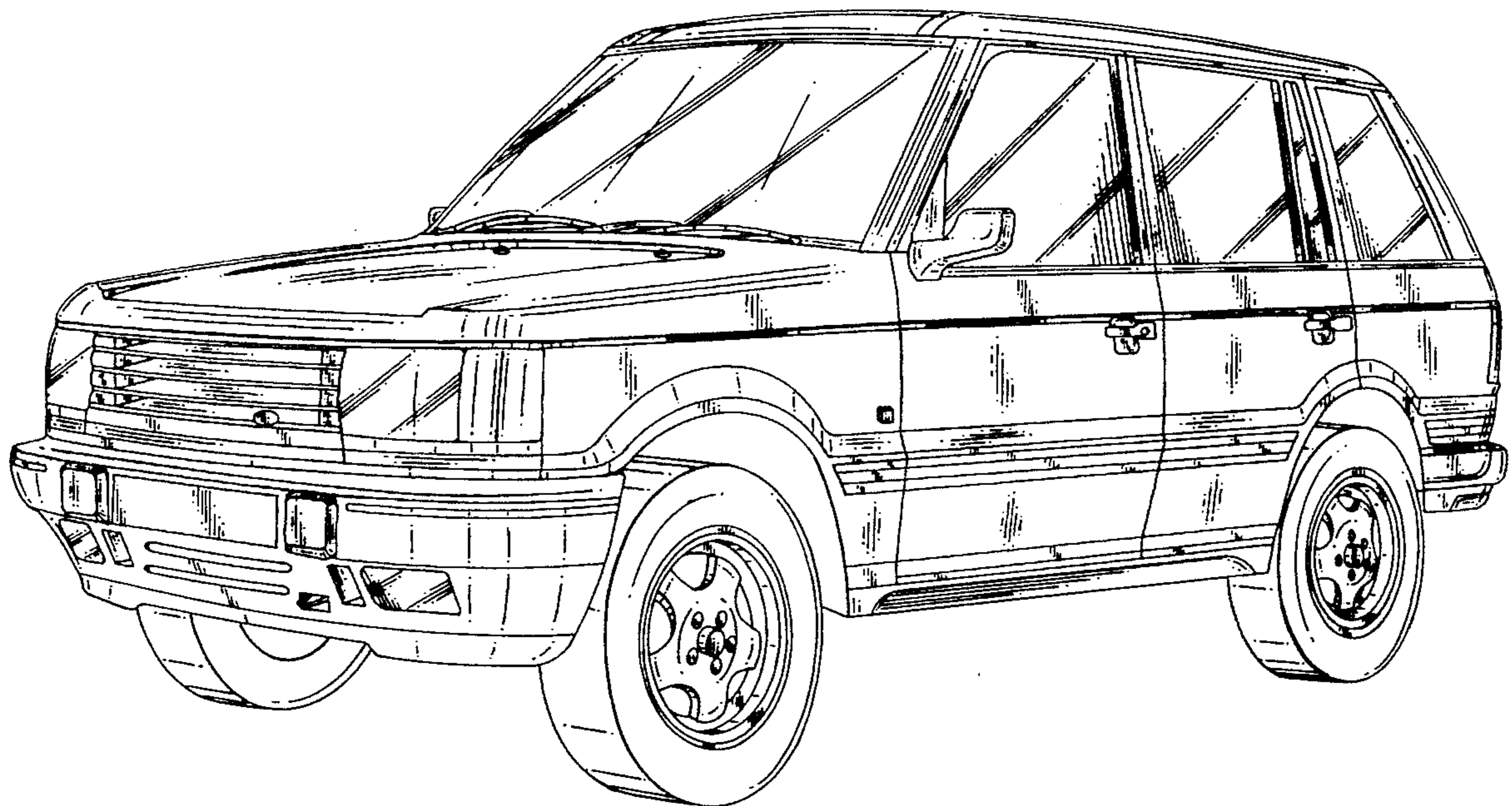

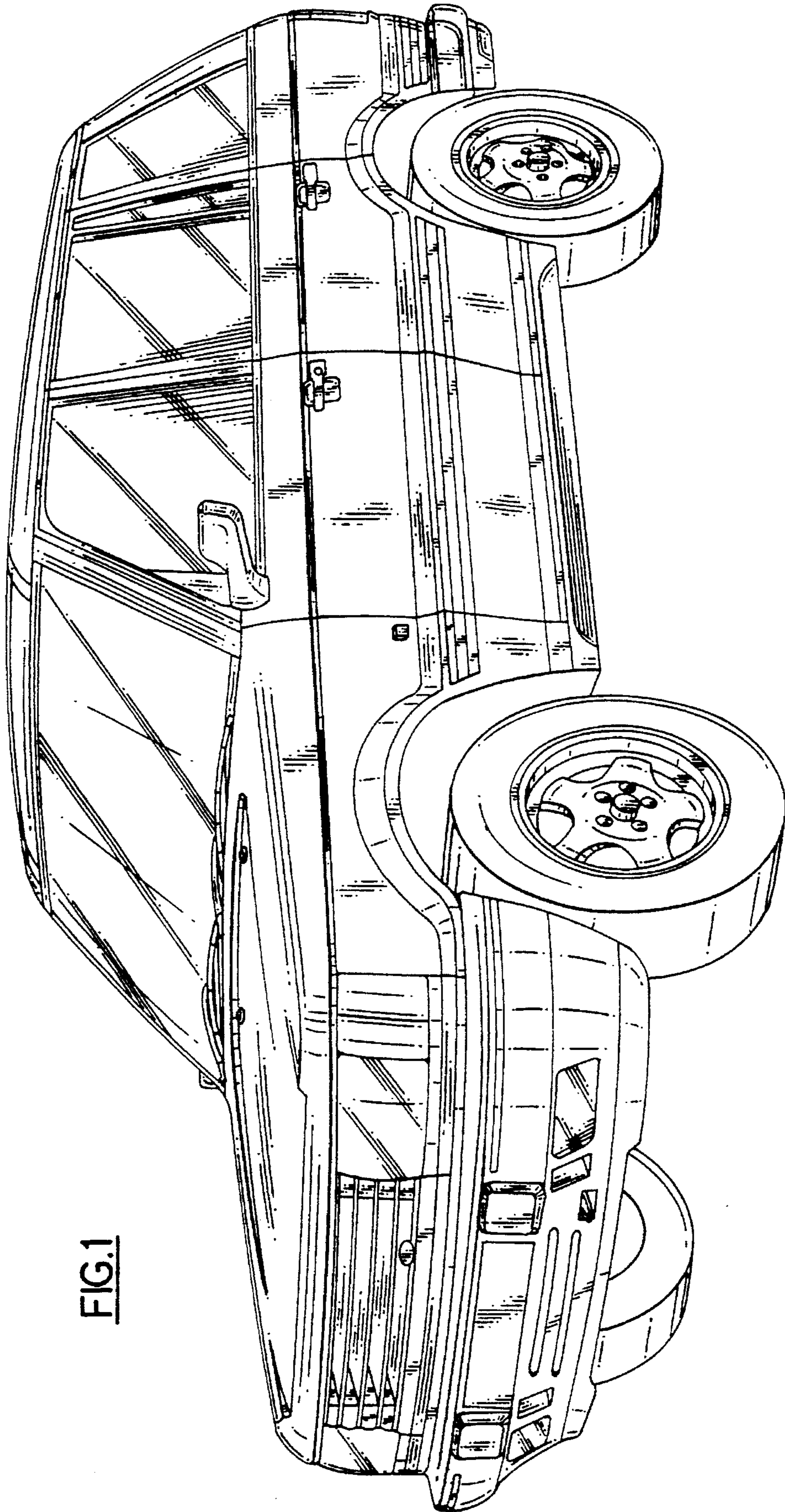

FIG.1

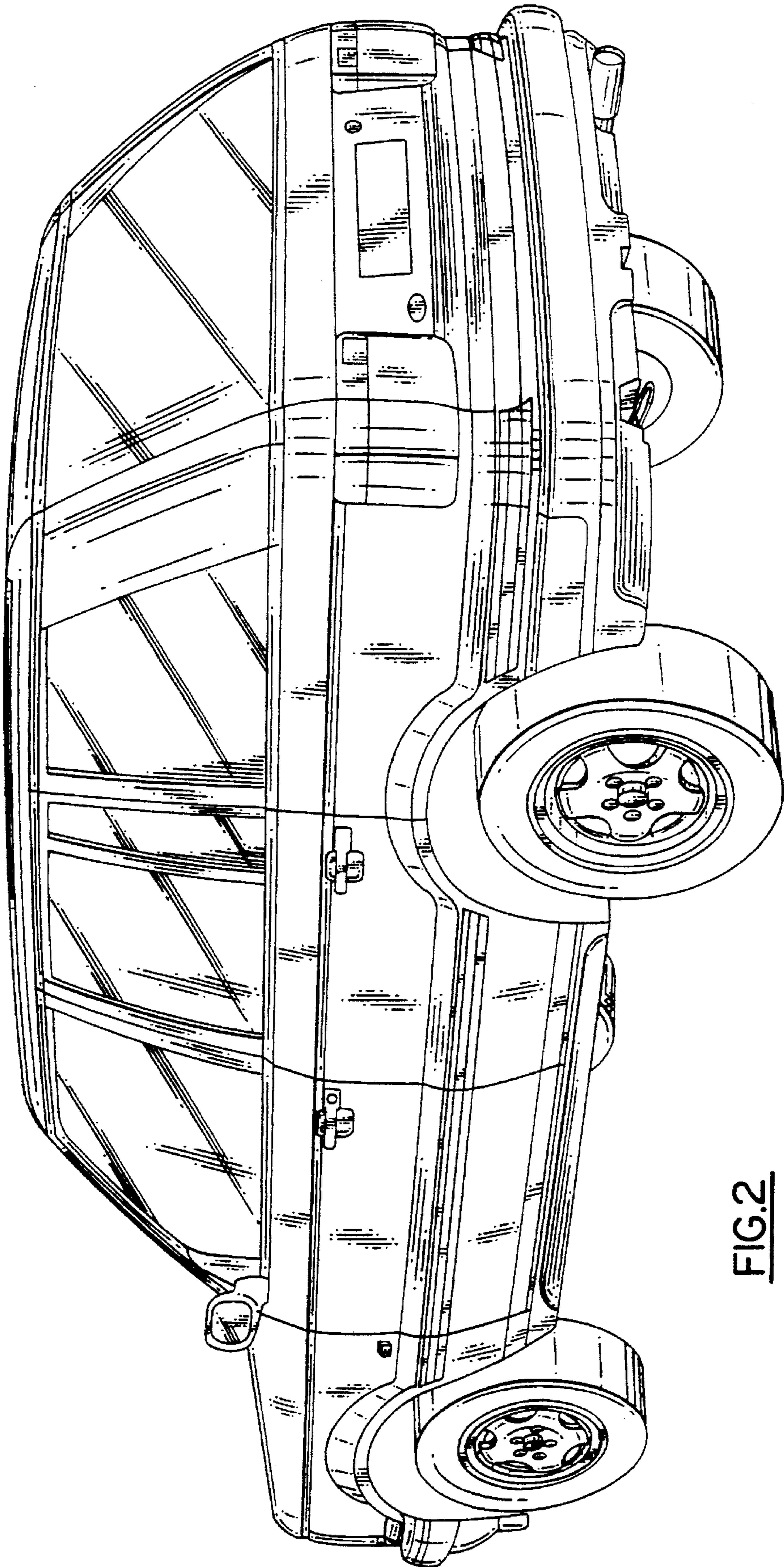

FIG. 2

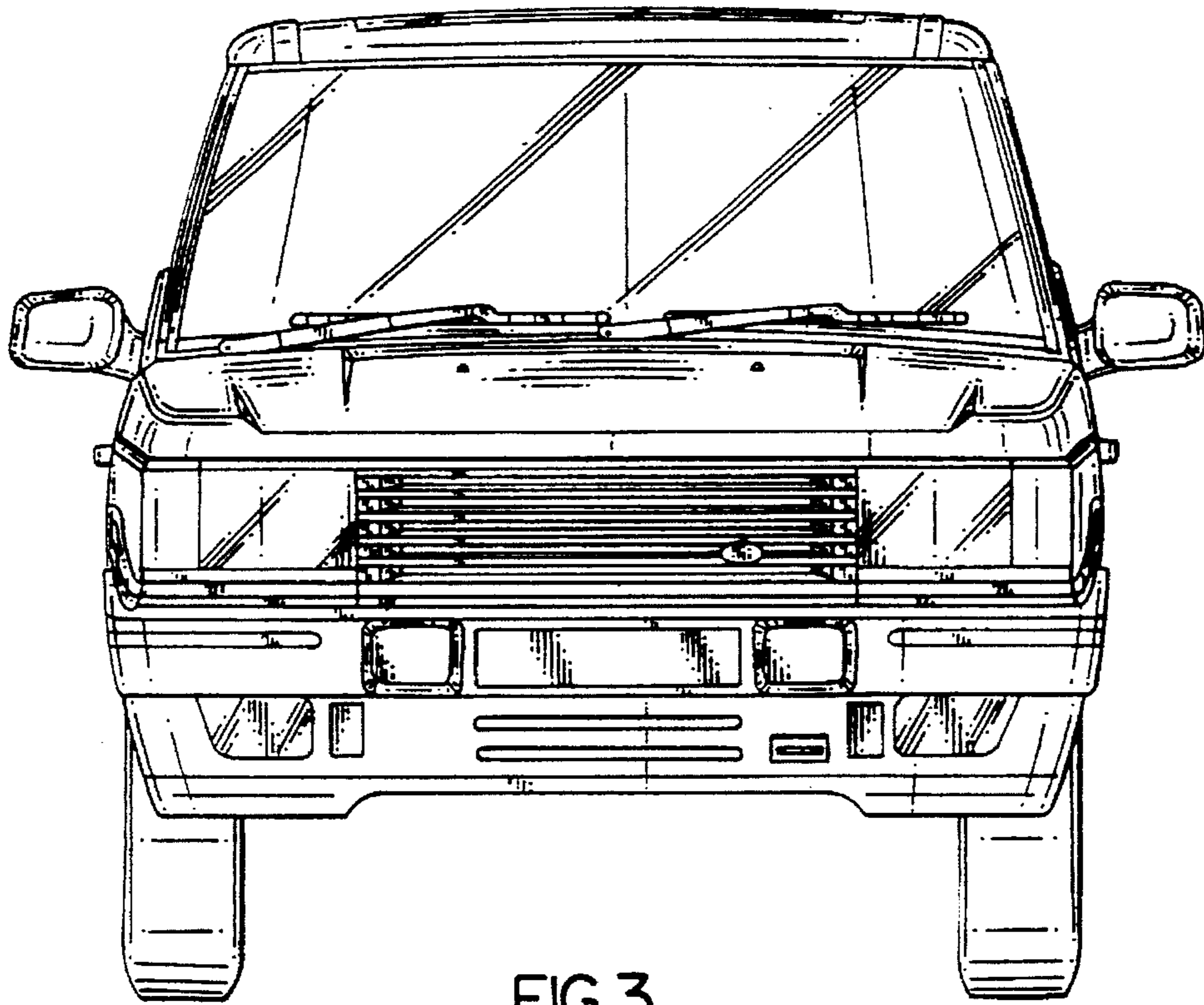

FIG. 3

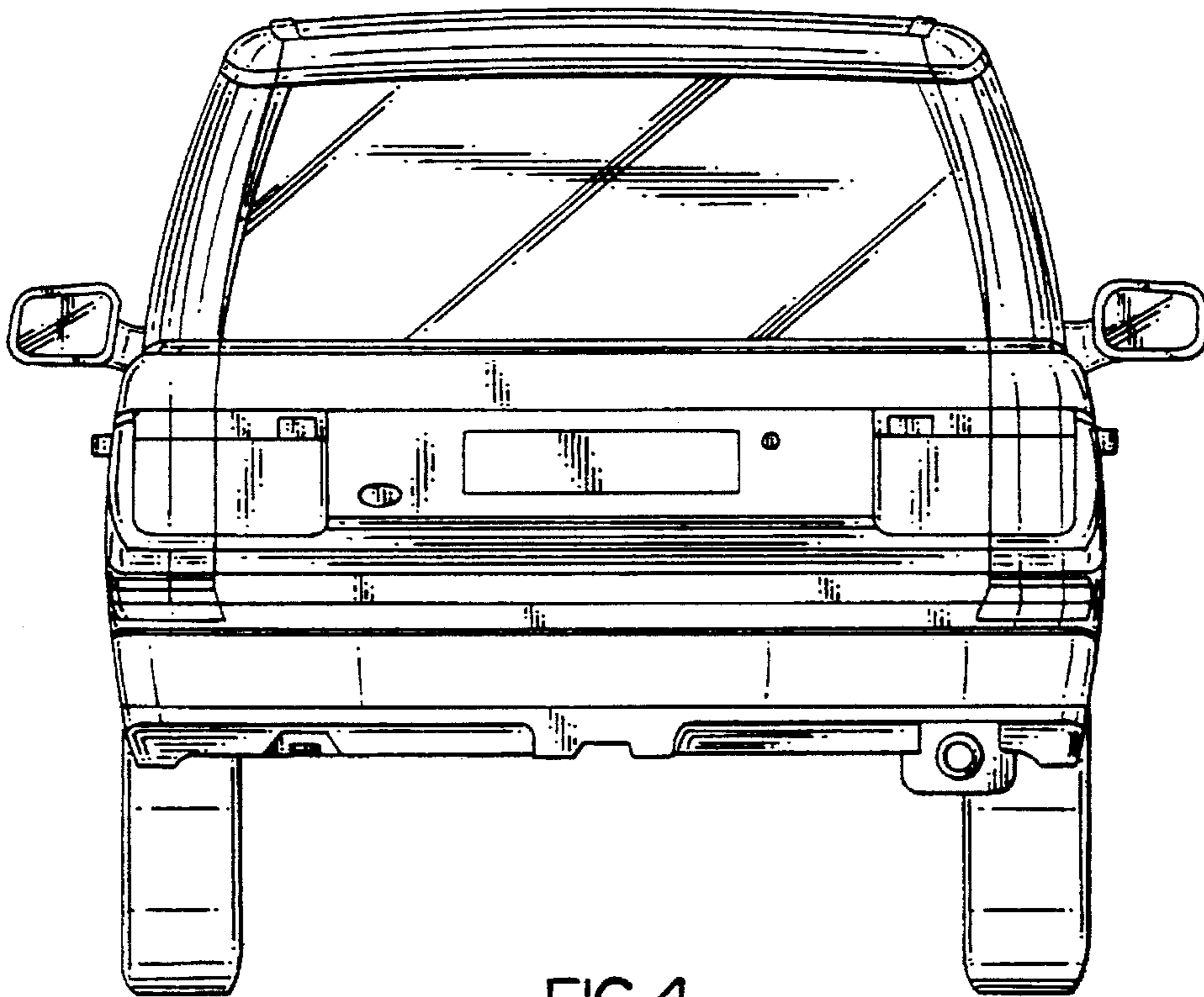

FIG. 4

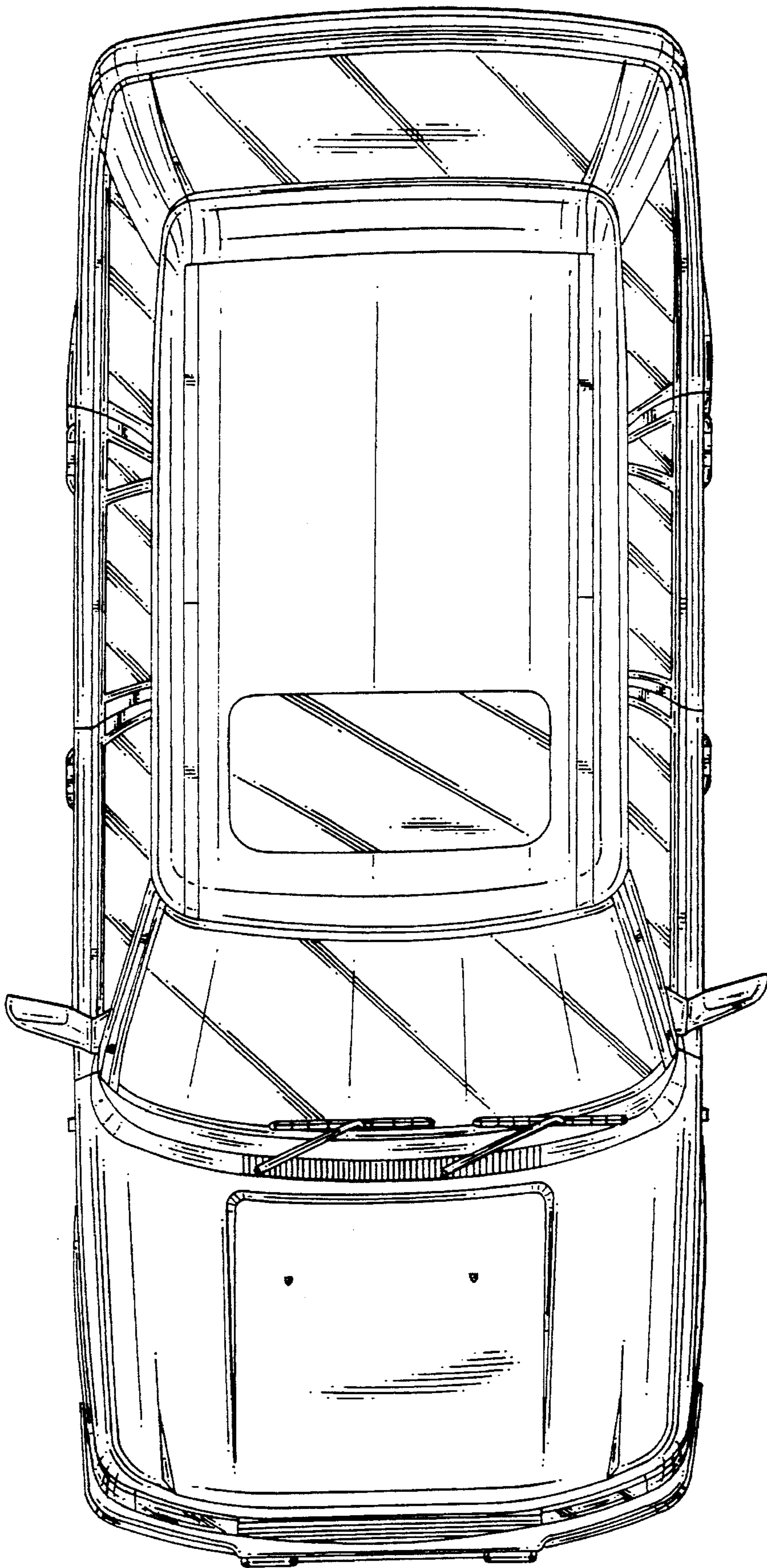

FIG. 5

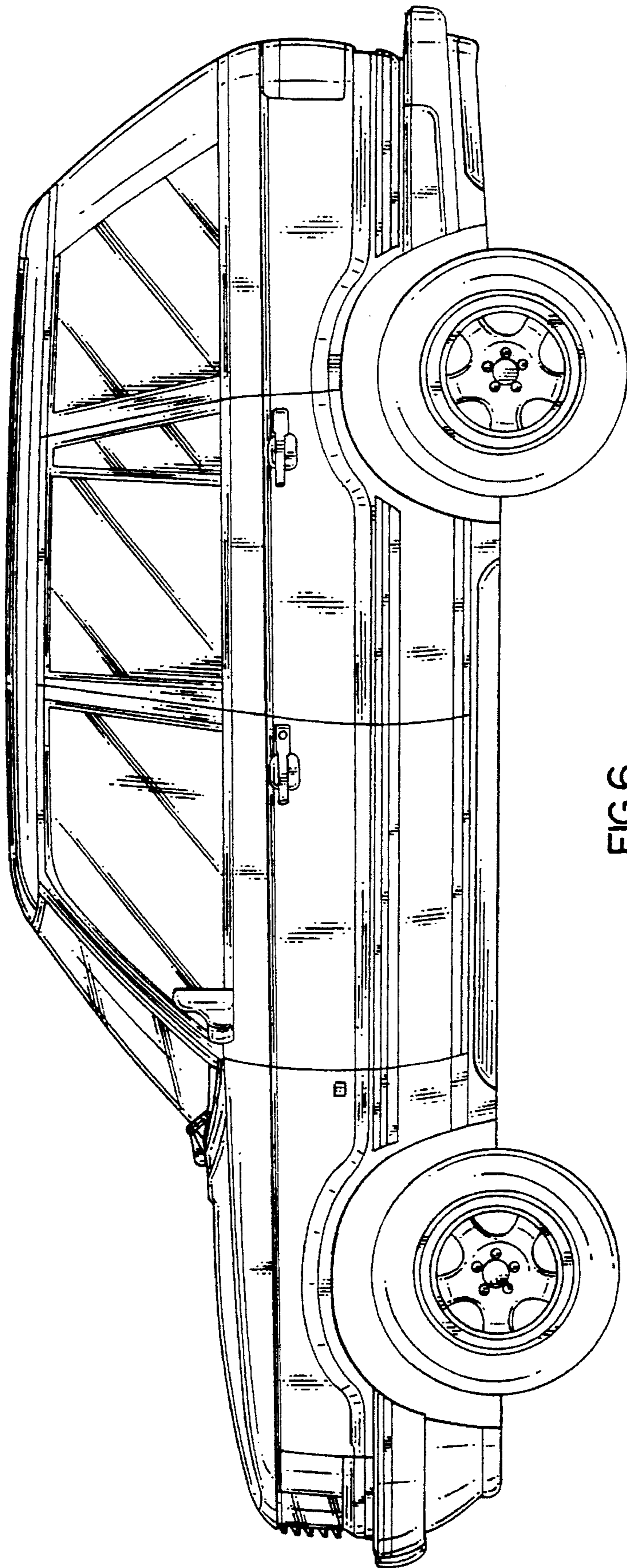

FIG.6