



US00D374282S

United States Patent [19]

Hoftman

[11] Patent Number: Des. 374,282

[45] Date of Patent: **Oct. 1, 1996

[54] **SURGICAL NEEDLE COUNTER AND SHARPS COLLECTION BOX WITH REMOVABLE CLOSURE TAPES**

3,682,366	8/1972	Chung	229/123.1
5,024,326	6/1991	Sandel et al.	206/363 X
5,346,677	9/1994	Risk	206/363 X

[76] Inventor: **Moshe M. Hoftman**, 9410 DeSoto Ave., Chatsworth, Calif. 91311

Primary Examiner—Louis S. Zarfaz
Assistant Examiner—Frank Martinez
Attorney, Agent, or Firm—Allan M. Shapiro

[**] Term: **14 Years**

[57] **CLAIM**

[21] Appl. No.: **36,164**

The ornamental design for a surgical needle counter and sharps collection box with removable closure tapes, as shown and described.

[22] Filed: **Mar. 14, 1995**

[52] U.S. Cl. **D24/130**; 206/363; 229/123.1; D9/499

DESCRIPTION

[58] **Field of Search** D3/203; D24/130; D9/303, 432, 341, 416, 419, 423, 499; 206/339, 363, 380, 450, 558, 828, 813; 229/123.1, 125.37

FIG. 1 is a reduced scale perspective view of a surgical needle counter and sharps collection box with removable closure tapes, showing my new design; FIG. 2 is a bottom plan view thereof; FIG. 3 is a side elevational view thereof; FIG. 4 is a reduced scale perspective view of a second embodiment thereof; FIG. 5 is a side elevational view of the embodiment of FIG. 4; and, FIG. 6 is a reduced scale perspective view of a third embodiment thereof.

[56] **References Cited**

U.S. PATENT DOCUMENTS

D. 254,122	2/1980	Wintz	D9/341
D. 359,450	6/1995	Thomas	D9/499
682,522	9/1901	Boekel et al.	206/363
2,239,733	4/1942	Newsom	229/125.37 X
3,081,927	3/1963	Hayhurst	229/123.1 X

1 Claim, 1 Drawing Sheet

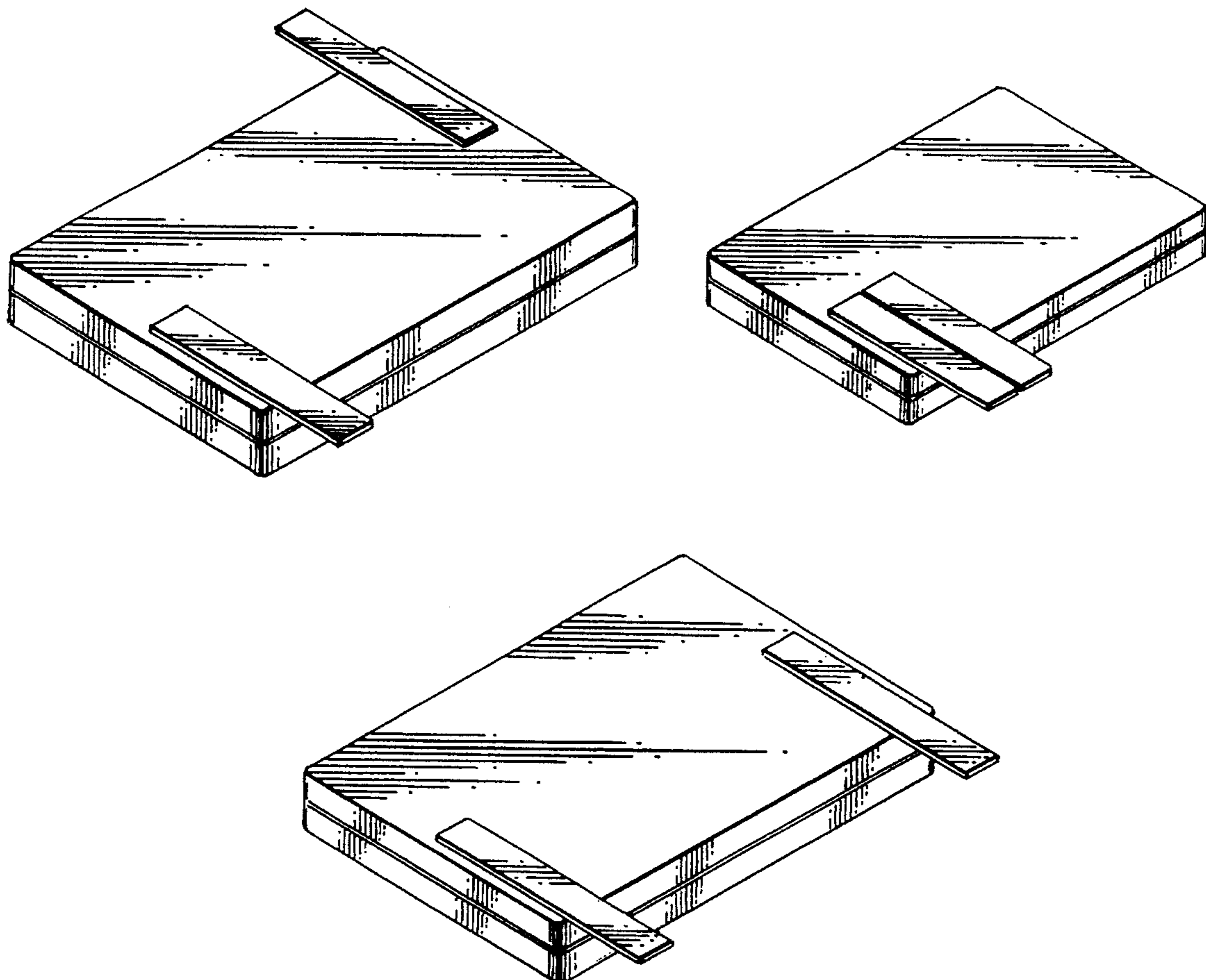

FIG. 1

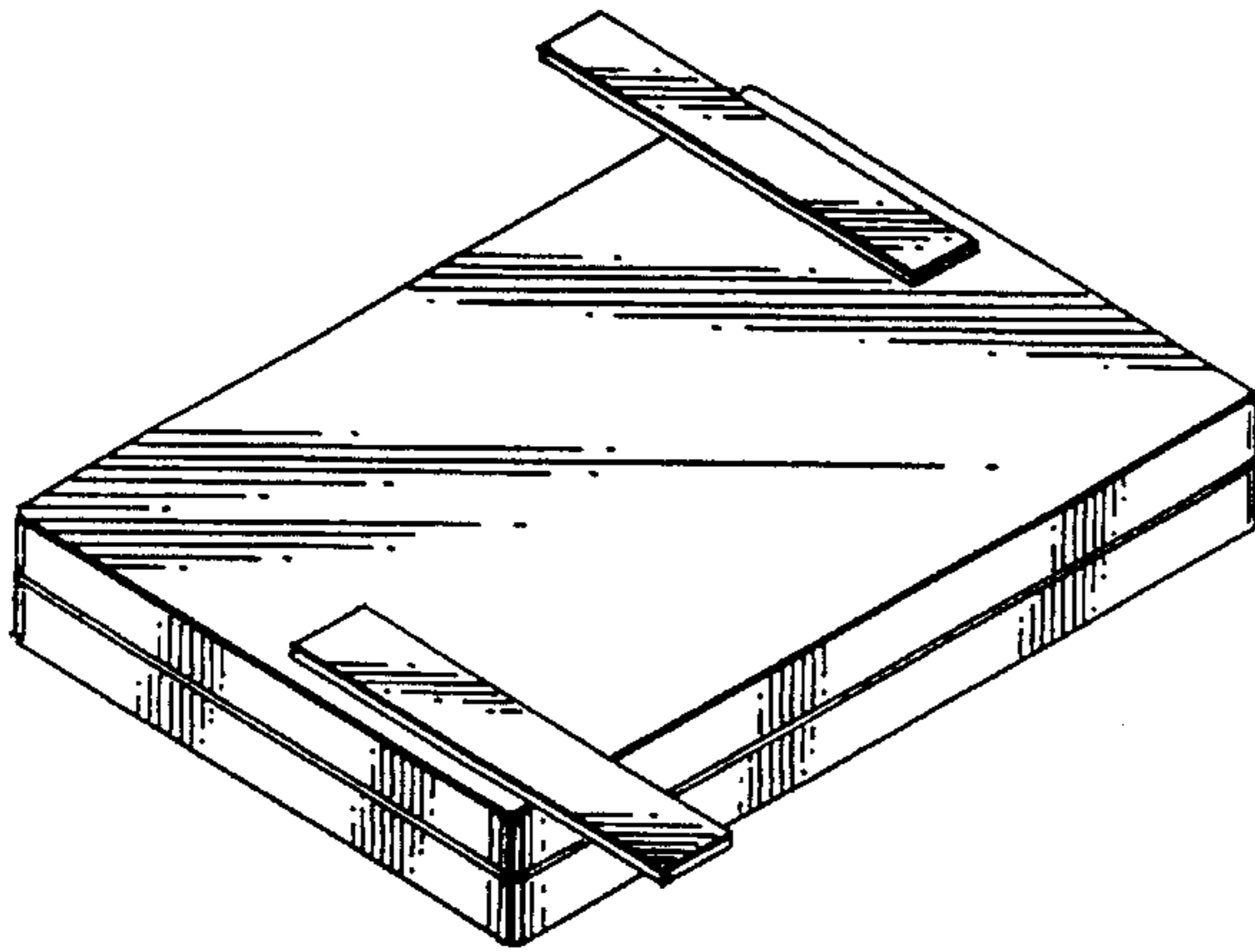

FIG. 6

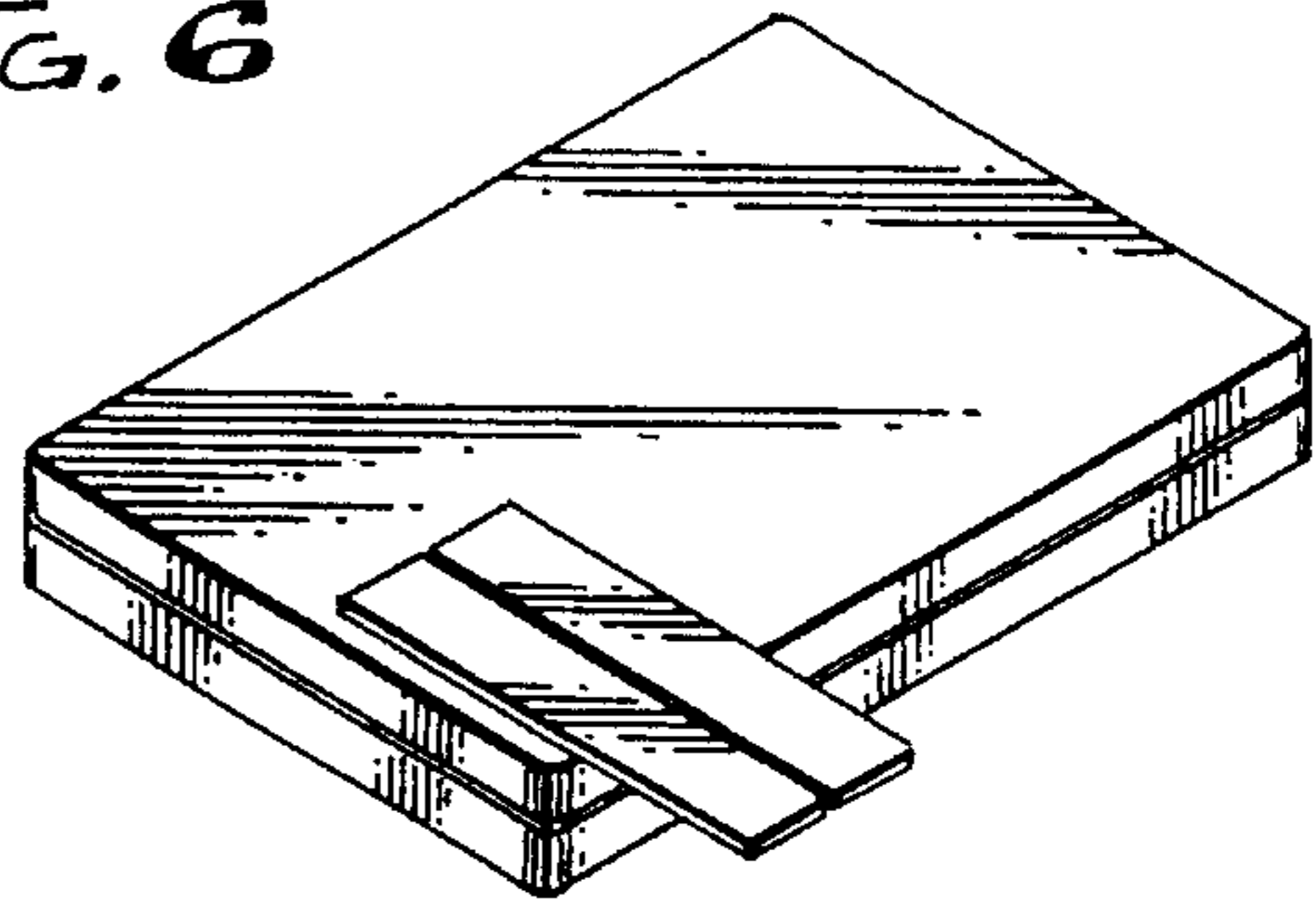

FIG. 3

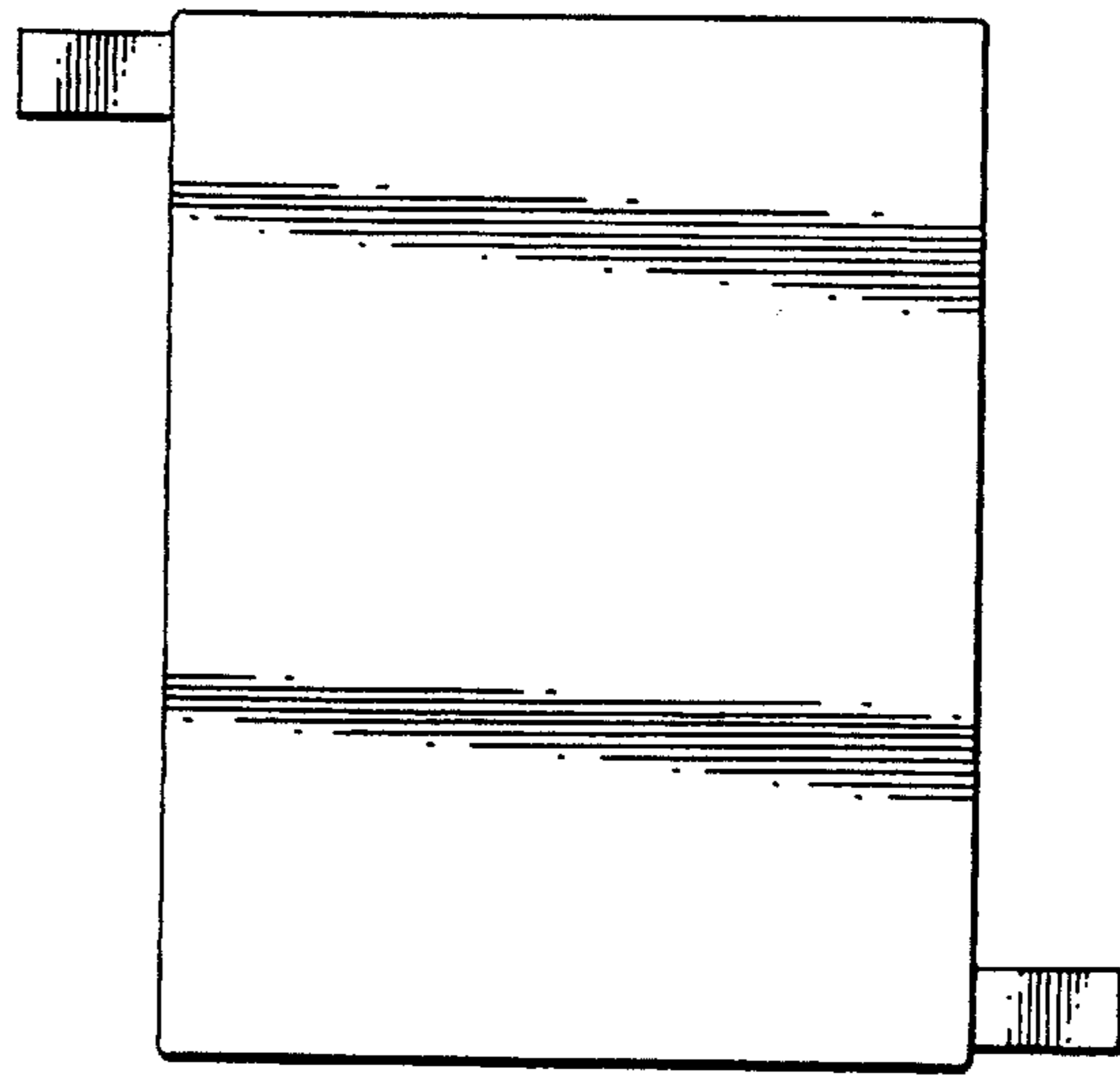
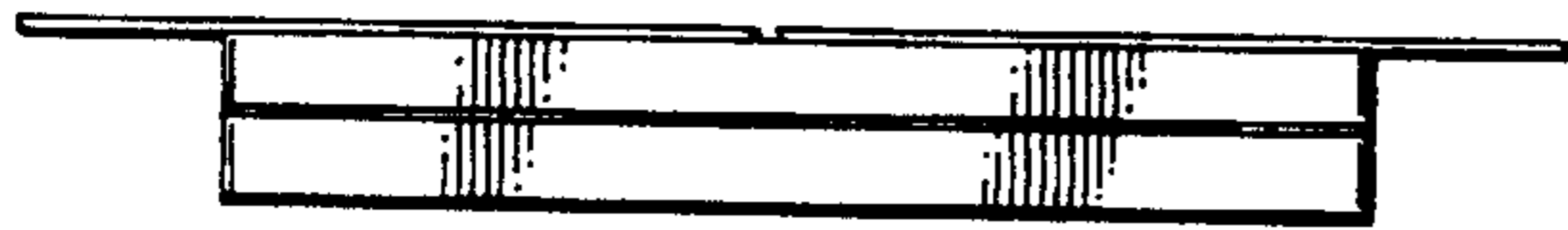

FIG. 2

FIG. 4

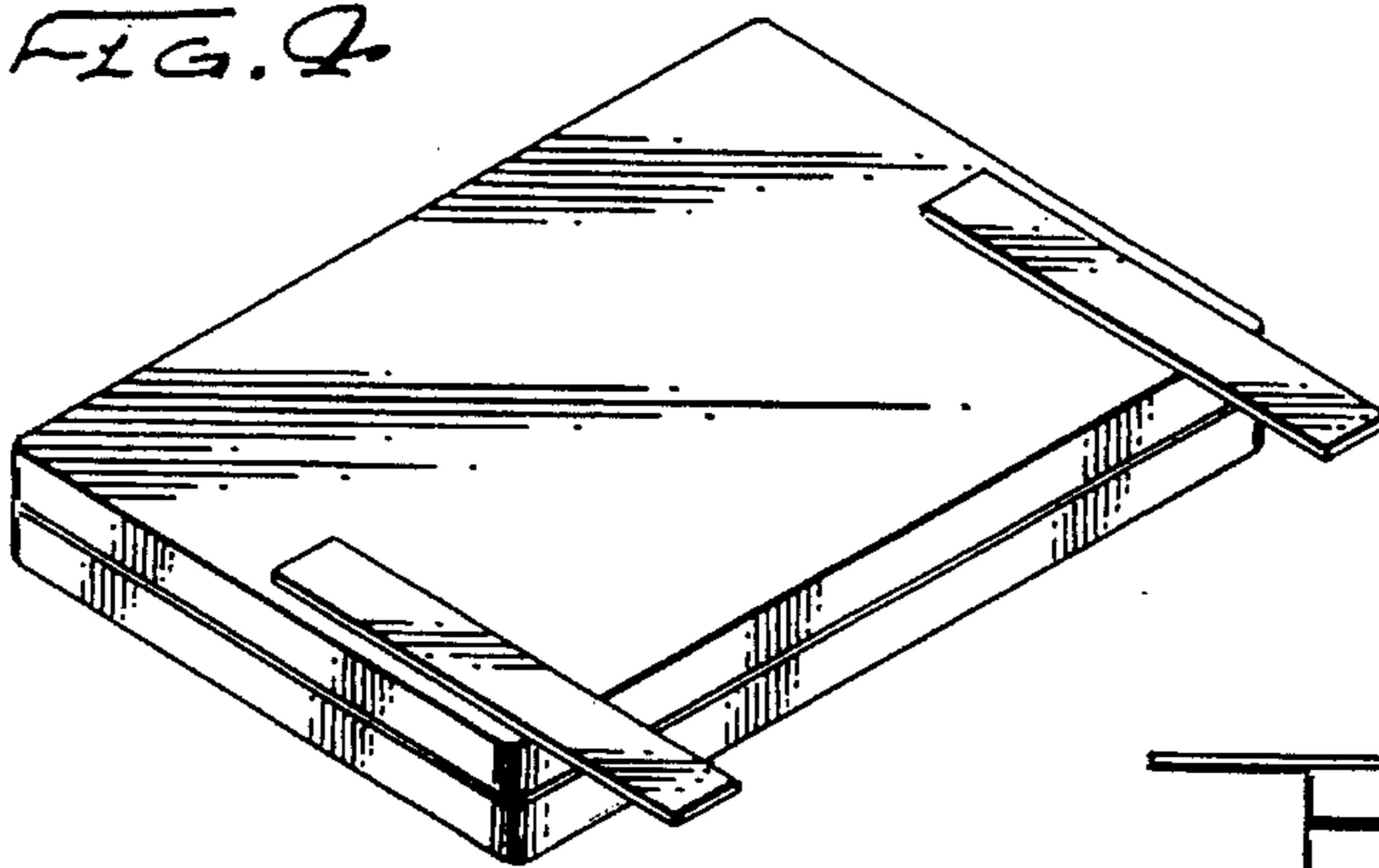

FIG. 5

