



US00D374205S

United States Patent [19]
Levinkron

[11] **Patent Number: Des. 374,205**
[45] **Date of Patent: **Oct. 1, 1996**

[54] **BICYCLE BRAKE LEVER**

5,481,934 1/1996 Tayawa 74/475

[76] Inventor: **Arie Levinkron**, 7230 Cirrus Way,
West Hills, Calif. 91307

OTHER PUBLICATIONS

Colorado Cyclist, Spring 1995, p. 55, the Dia-Compe PC-5
& PC-8 brake levers & Avid brake levers.

[**] Term: **14 Years**

Primary Examiner—Melody N. Brown
Attorney, Agent, or Firm—Jack C. Munro

[21] Appl. No.: **50,255**

[22] Filed: **Feb. 12, 1996**

[57] **CLAIM**

[52] U.S. Cl. **D12/179**

[58] Field of Search D12/179; 74/502.2,
74/489, 415, 551.8, 551.9, 523, 475

The ornamental design for a bicycle brake lever, as shown
and described.

[56] **References Cited**

DESCRIPTION

U.S. PATENT DOCUMENTS

D. 286,034	10/1986	Giorgetti	D12/179
D. 339,096	9/1993	Bean et al.	D12/179
D. 346,575	5/1994	Lussier	D12/179
D. 356,061	3/1995	Gelbein	D12/179
D. 368,061	3/1996	Burns	D12/179
4,914,971	4/1990	Hinkens et al.	74/502.2
5,186,071	2/1993	Swasaki	74/475
5,385,070	1/1995	Tseng	74/502.2

FIG. 1 is a front elevational view of the bicycle brake lever,
showing my new design;
FIG. 2 is a right side elevational view thereof;
FIG. 3 is a left side elevational view thereof;
FIG. 4 is a rear elevational view thereof;
FIG. 5 is a top plan view thereof; and,
FIG. 6 is a bottom plan view thereof.

1 Claim, 1 Drawing Sheet

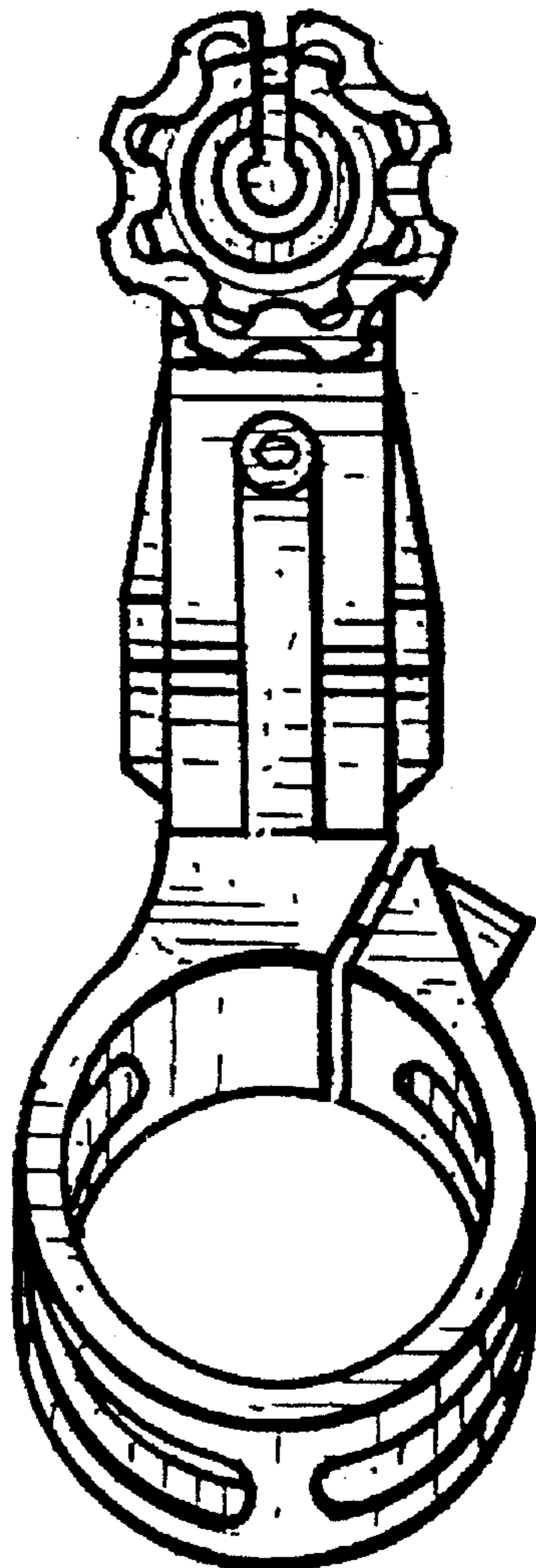

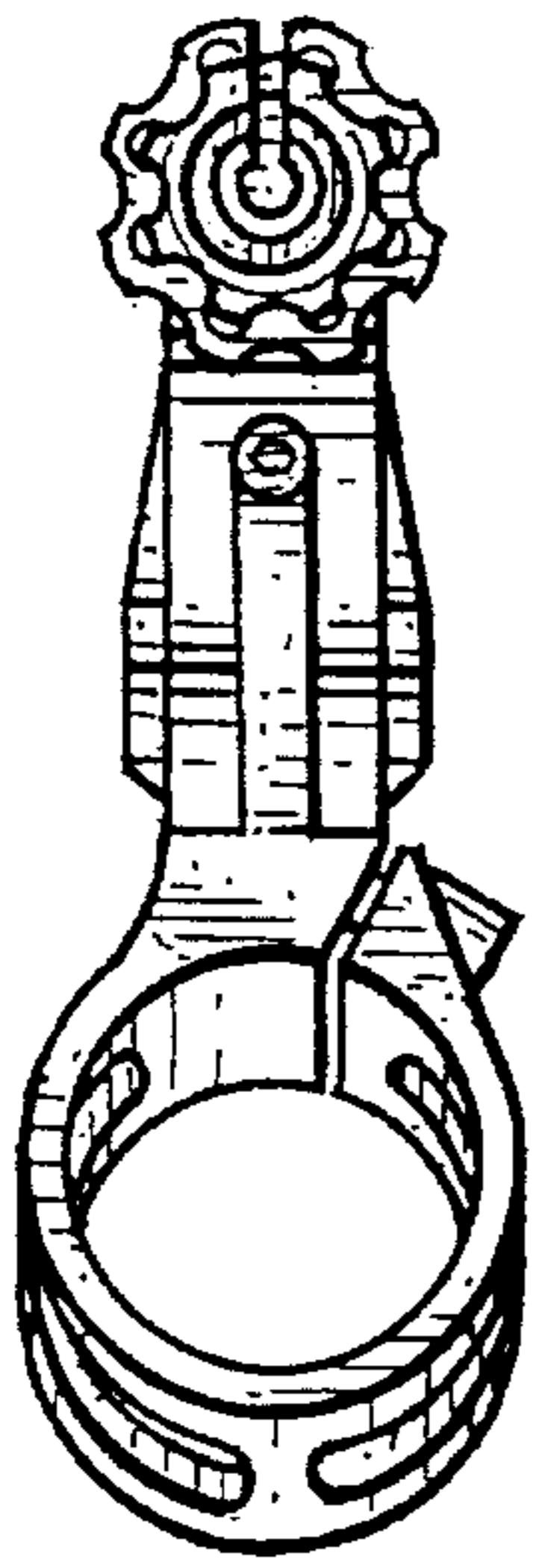

Fig. 1.

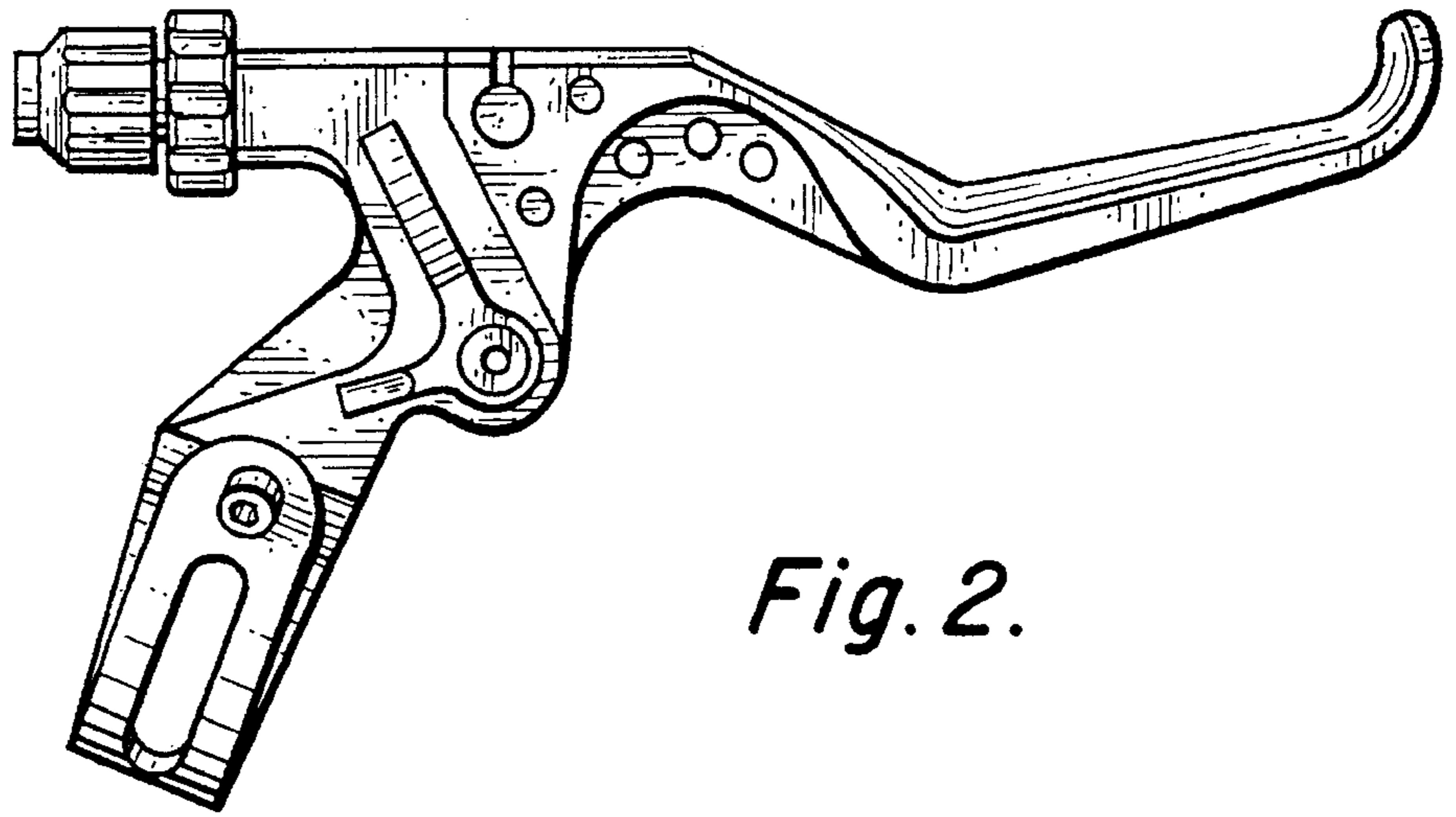

Fig. 2.

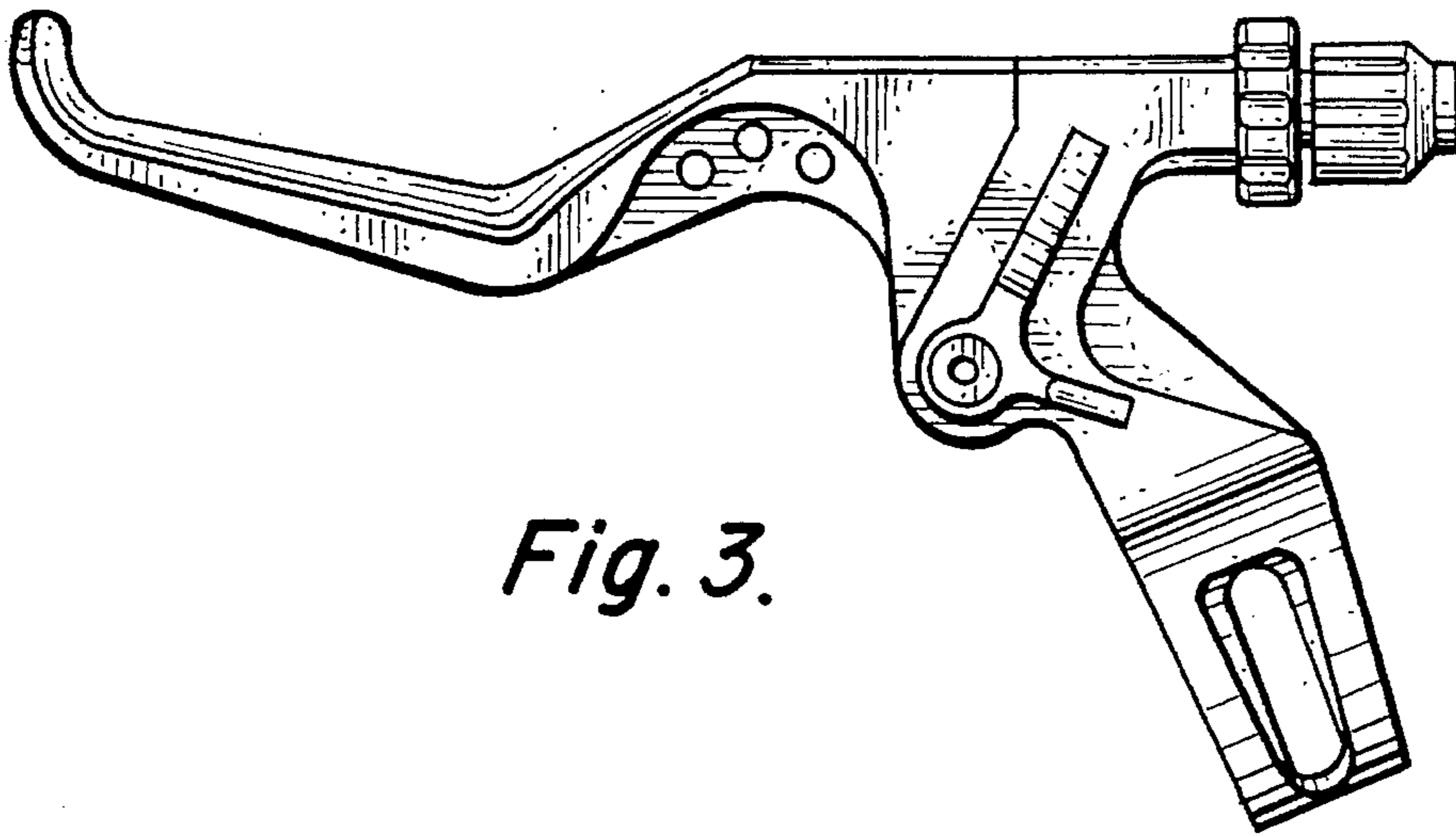

Fig. 3.

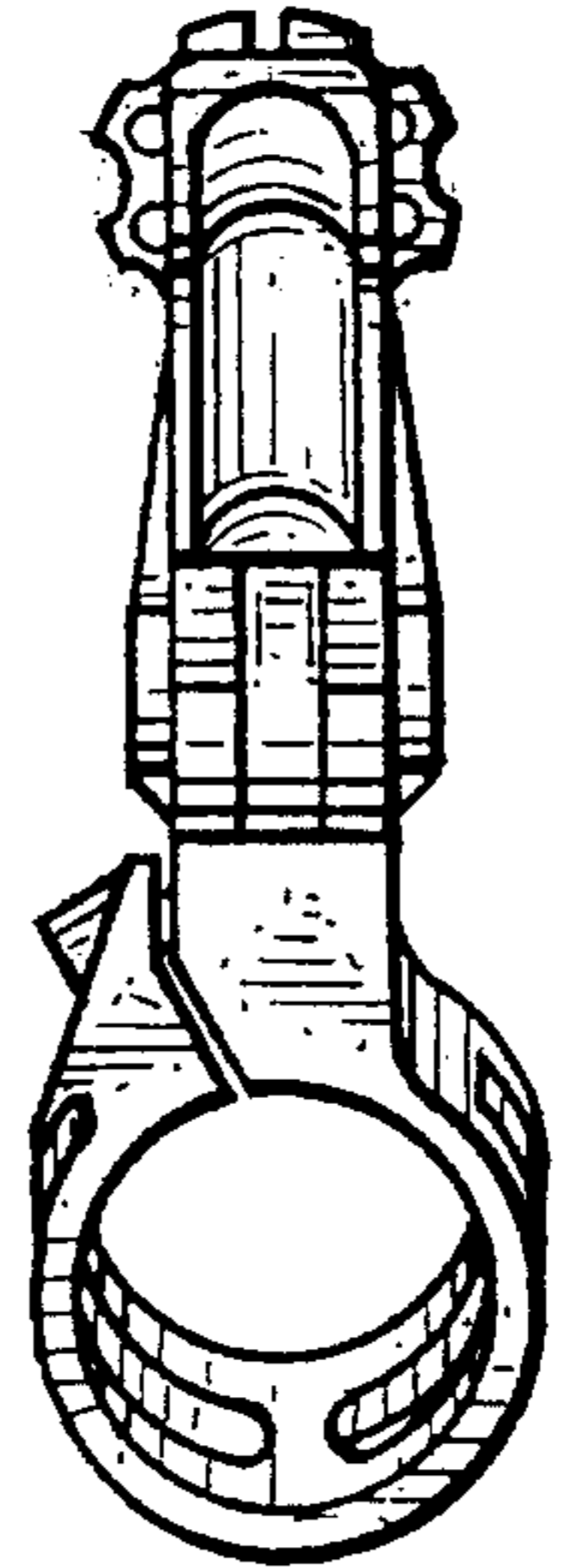

Fig. 4.

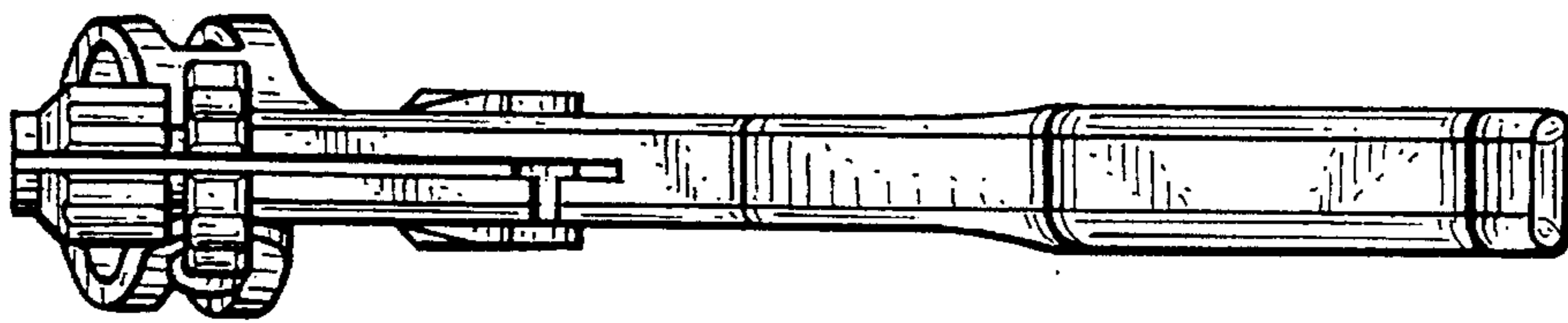

Fig. 5.

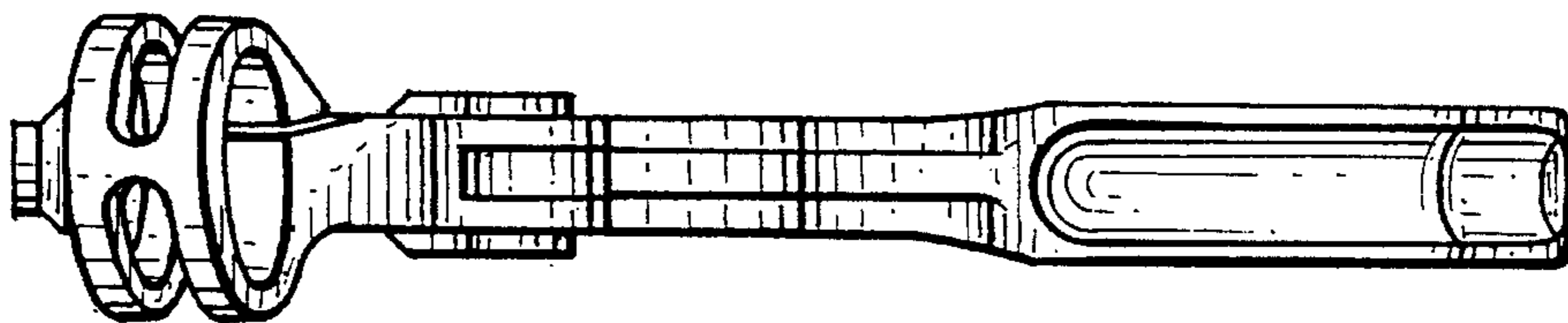

Fig. 6.