



US00D374125S

United States Patent [19]

[11] Patent Number: **Des. 374,125**

Bernstein et al.

[45] Date of Patent: ****Oct. 1, 1996**

[54] **COMBINATION HOOK-ON HIGH CHAIR AND BOOSTER SEAT**

Primary Examiner—Janice E. Seeger

Attorney, Agent, or Firm—Wolf, Greenfield & Sacks, P.C.

[75] Inventors: **Michael S. Bernstein**, Natick; **Randy L. Abrams**, Leominster, both of Mass.

[57] **CLAIM**

The ornamental design for a combination hook-on high chair and booster seat, as shown and described.

[73] Assignee: **Safety 1st, Inc.**, Chesnut Hill, Mass.

[**] Term: **14 Years**

DESCRIPTION

[21] Appl. No.: **37,107**

FIG. 1 is perspective view of the combination hook-on high chair and booster seat embodying our new design;

[22] Filed: **Apr. 4, 1995**

FIG. 2 is a right side elevation view of the seat of FIG. 1, the left side view being a mirror image thereof;

[52] U.S. Cl. **D6/333; D6/339**

FIG. 3 is a front elevation view thereof;

[58] Field of Search **D6/333, 336, 338, D6/339; 297/148, 151, 153**

FIG. 4 is a rear elevation view thereof;

[56] References Cited

FIG. 5 is a top plan view thereof;

U.S. PATENT DOCUMENTS

FIG. 6 is a bottom plan view thereof;

D. 254,999	5/1980	Dieter et al.	D6/338
D. 314,674	2/1991	Kohus .	
D. 330,842	11/1992	Meeker et al.	D6/333
D. 346,206	4/1994	Crossley et al. .	
D. 356,689	3/1995	Mariol	D6/333
3,078,101	2/1963	Reese .	
3,335,434	8/1967	Gamon .	
4,244,619	1/1981	Yoshimura .	
4,453,764	6/1984	Hennessy .	
4,586,747	5/1986	Taylor .	
4,603,903	8/1986	Moscovitch .	
4,770,468	9/1988	Shubin .	
4,818,016	4/1989	Mariol et al.	297/153
5,183,311	2/1993	Meeker .	

FIG. 7 is a perspective view for the seat shown in FIG. 1 with the tray removed;

FIG. 8 is a right side elevation view of the seat shown in FIG. 7, the right side elevation being a mirror image thereof;

FIG. 9 is perspective view of the seat shown in FIG. 1 but with the hook-on frame removed and the tray disposed in an alternative position;

FIG. 10 is a right side elevation view of the seat shown in FIG. 9, the left side elevation view being a mirror image thereof;

FIG. 11 is a perspective view of the seat shown in FIG. 1 with the hook-on frame and tray removed; and,

FIG. 12 is a right side elevation view of the seat shown in FIG. 11, the left side elevation view being the mirror image thereof.

FOREIGN PATENT DOCUMENTS

2025359 2/1992 United Kingdom .

OTHER PUBLICATIONS

Go'n'Grow instruction manual, Jul. 1991.

Safety 1st catalog, 1995, pp. 14,36.

Step-by-step brochure.

The broken lines in FIG. 2 are for environmental purposes only and form no part of my claimed design.

1 Claim, 7 Drawing Sheets

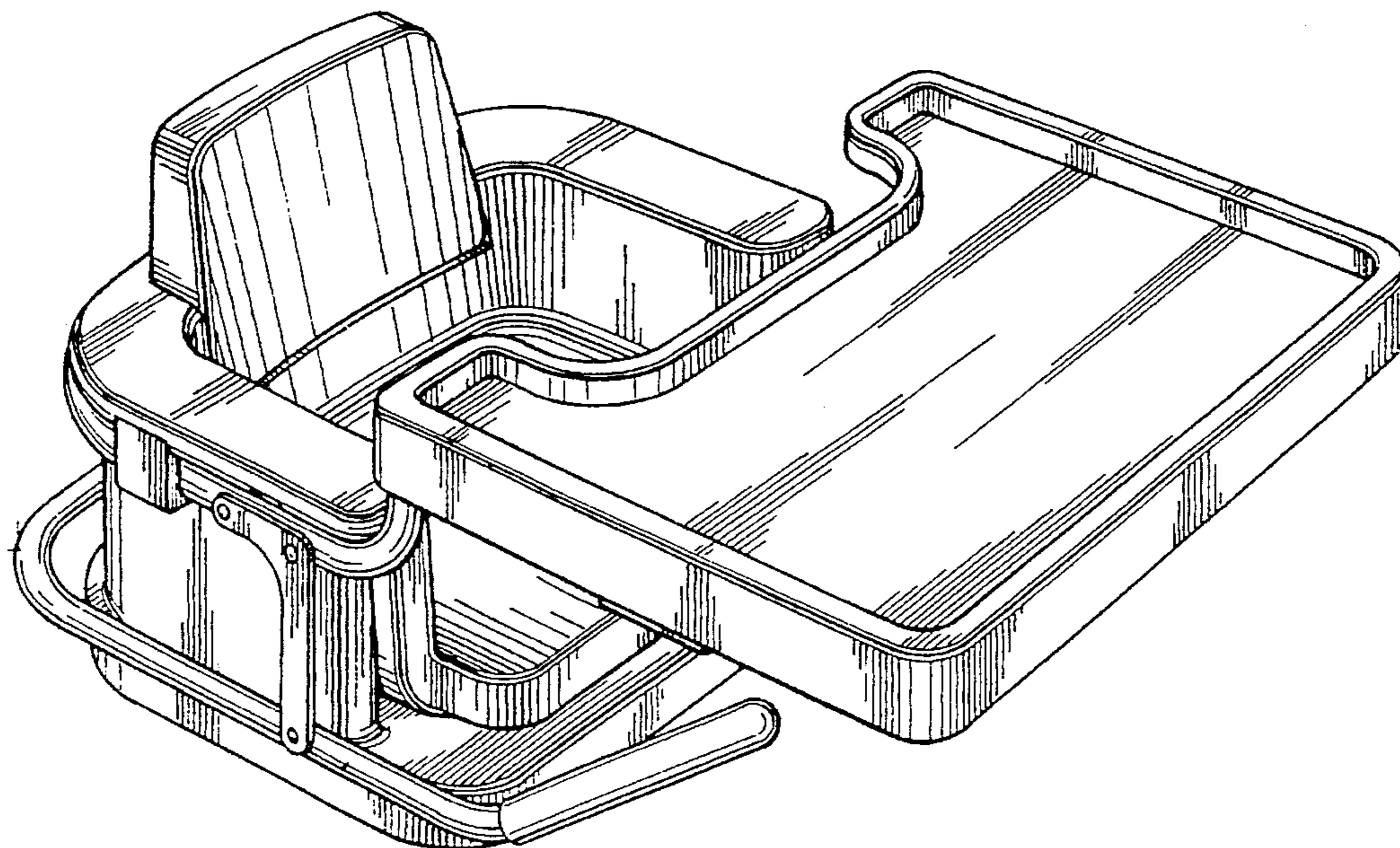

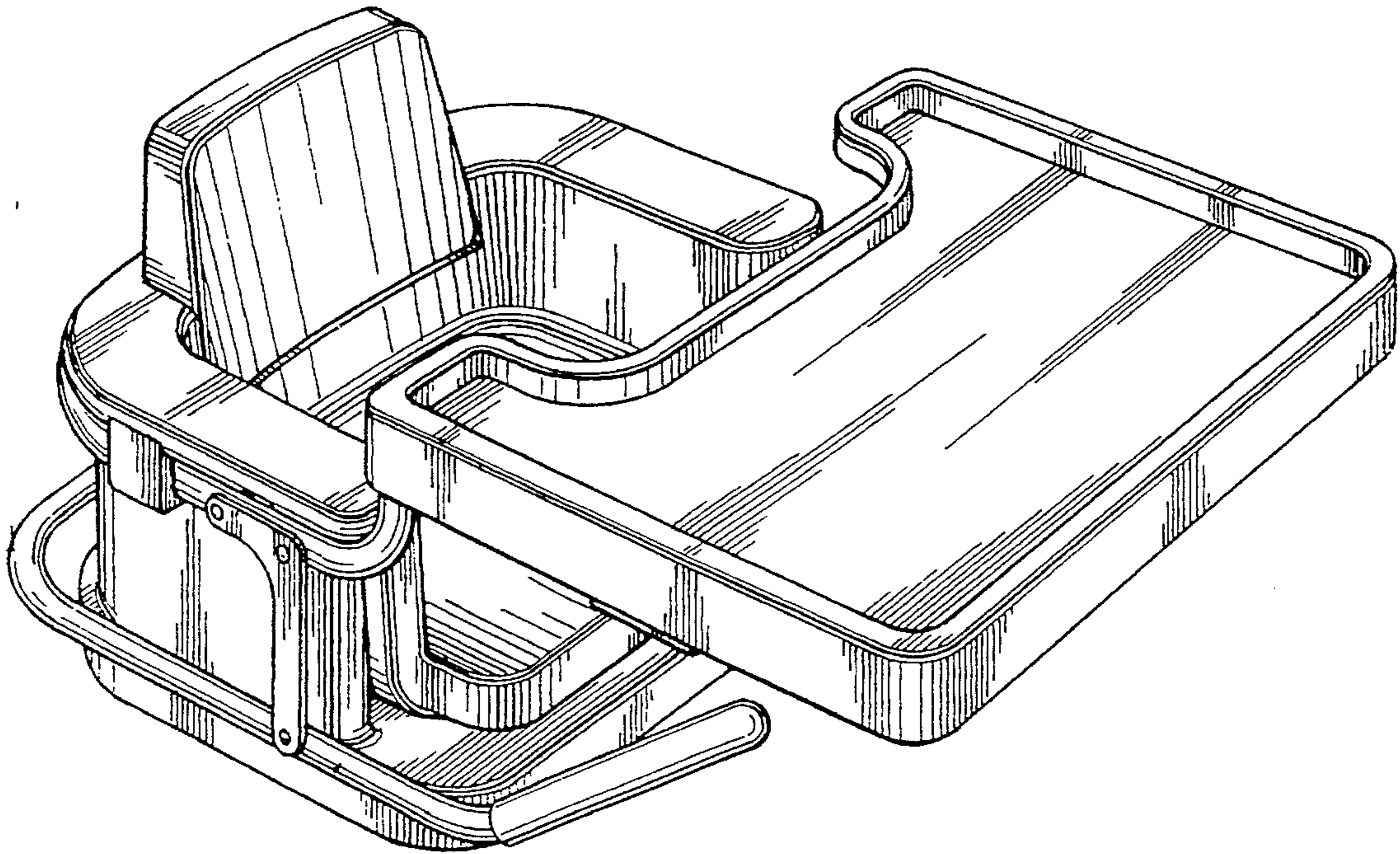

Fig. 1

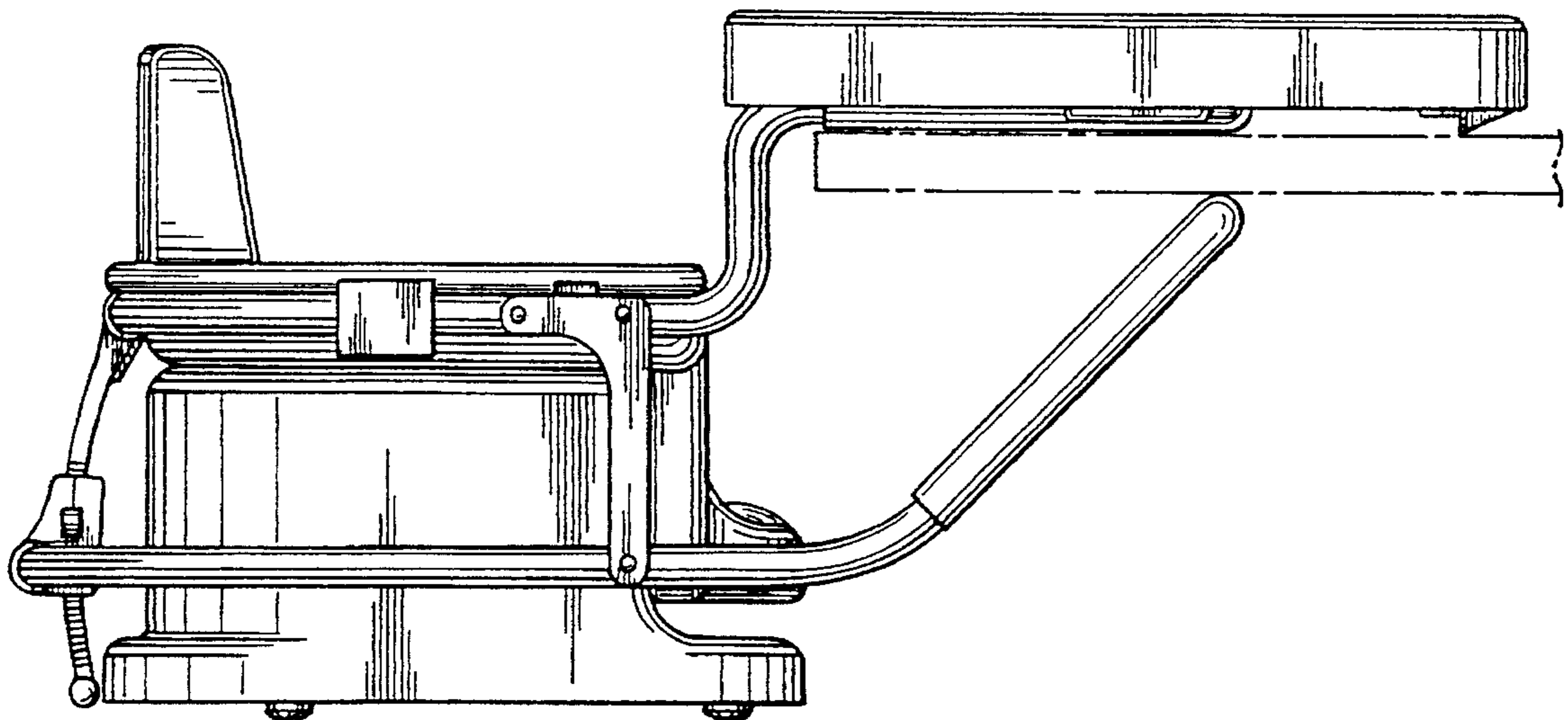

Fig. 2

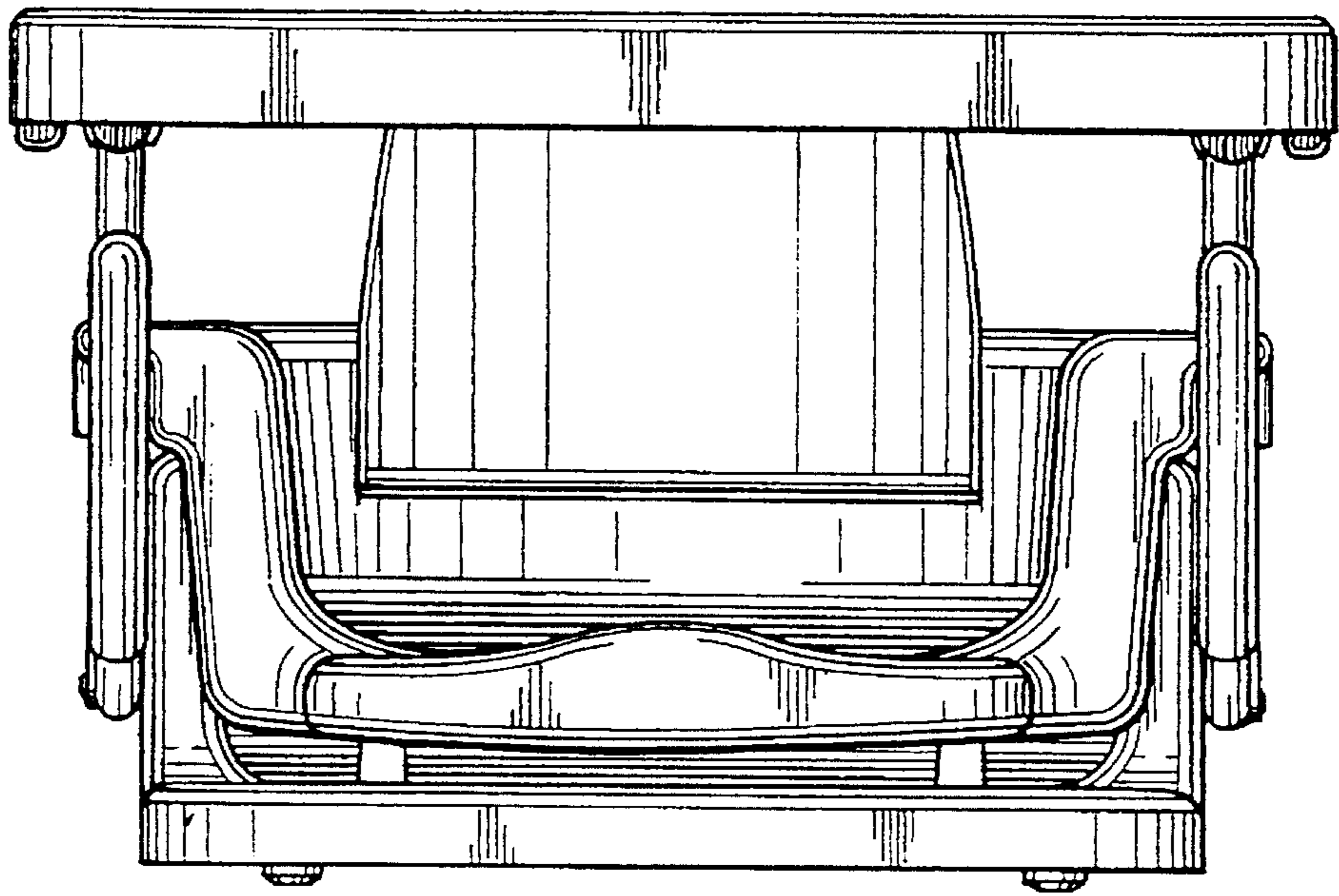

Fig. 3

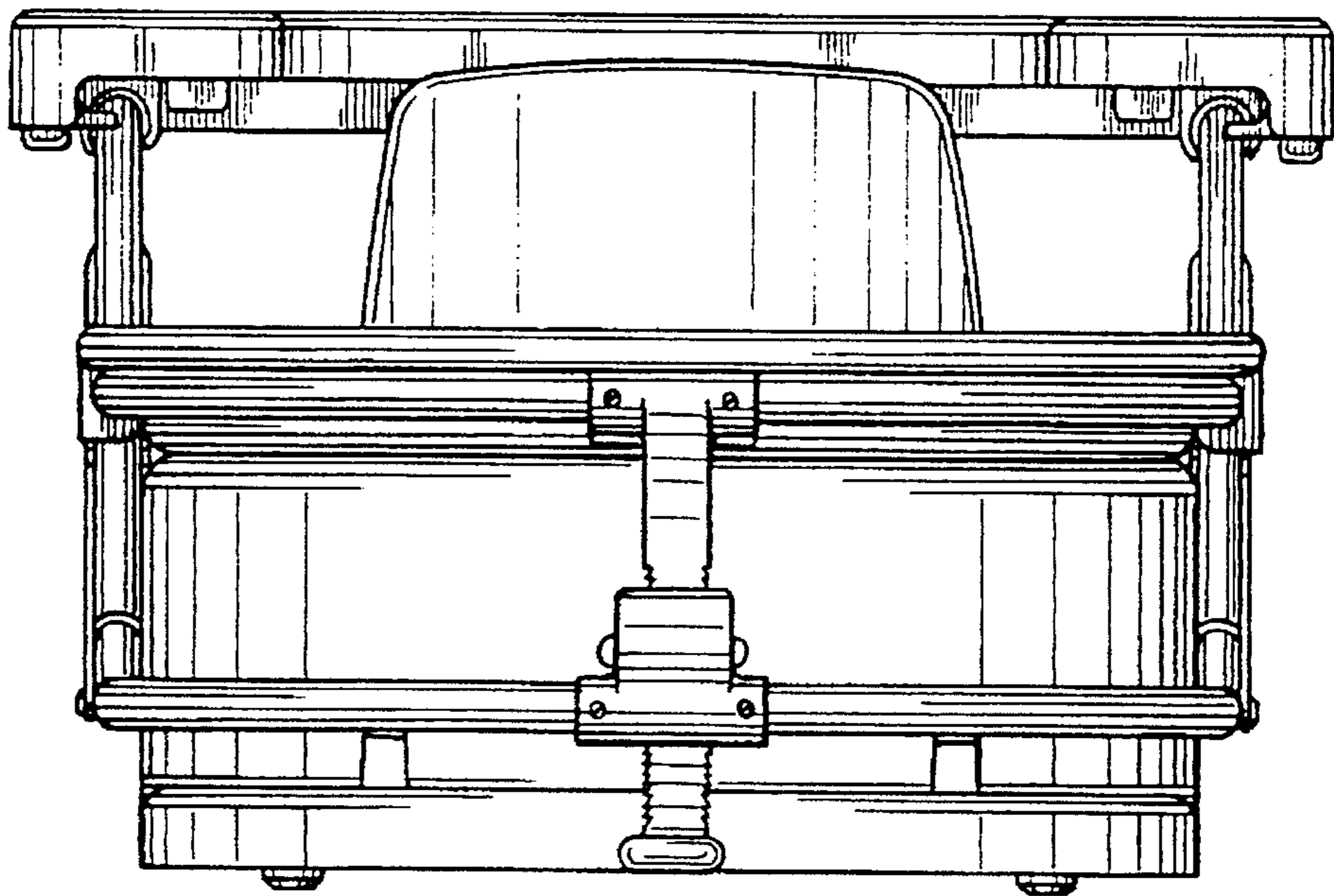

Fig. 4

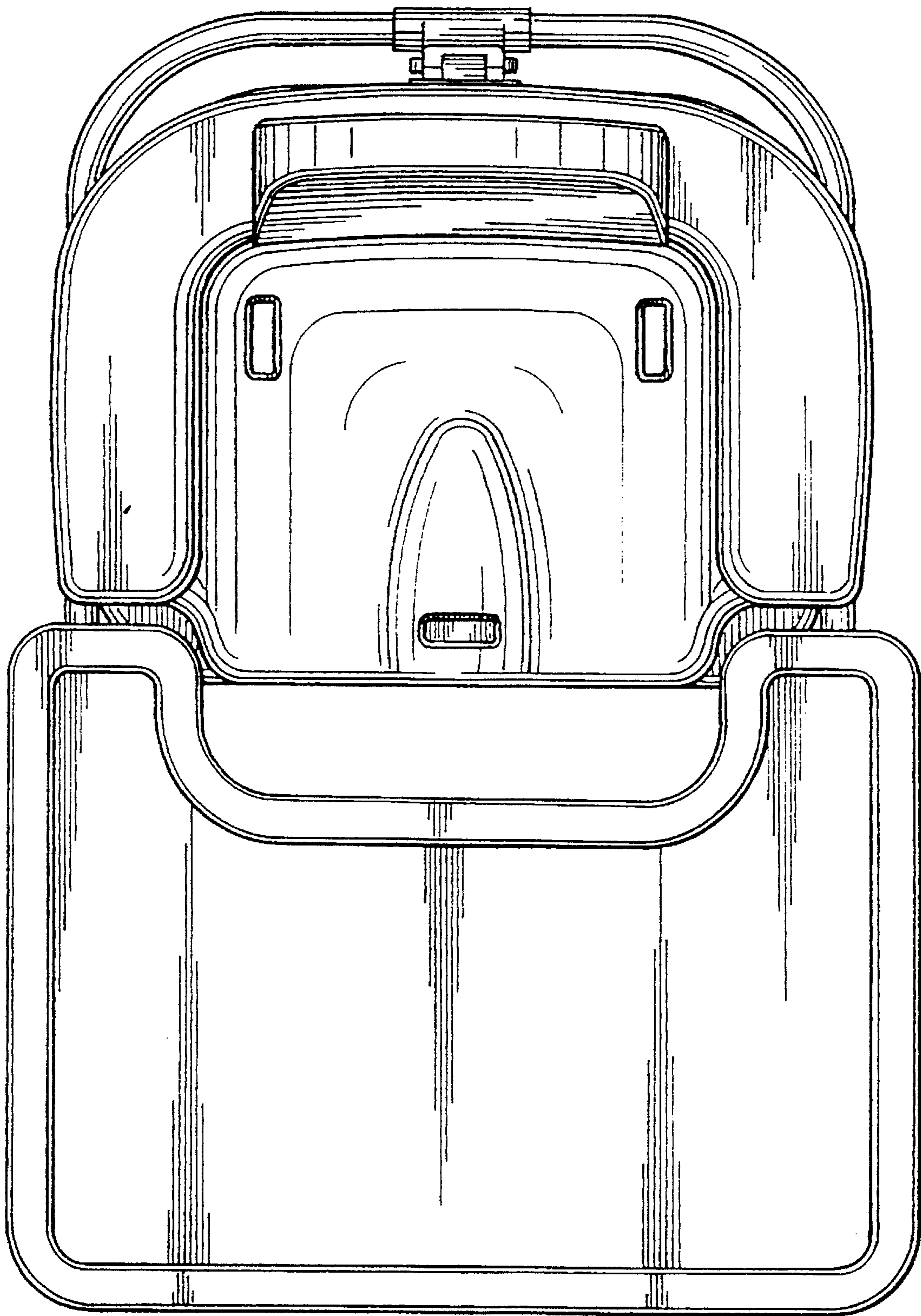

Fig. 5

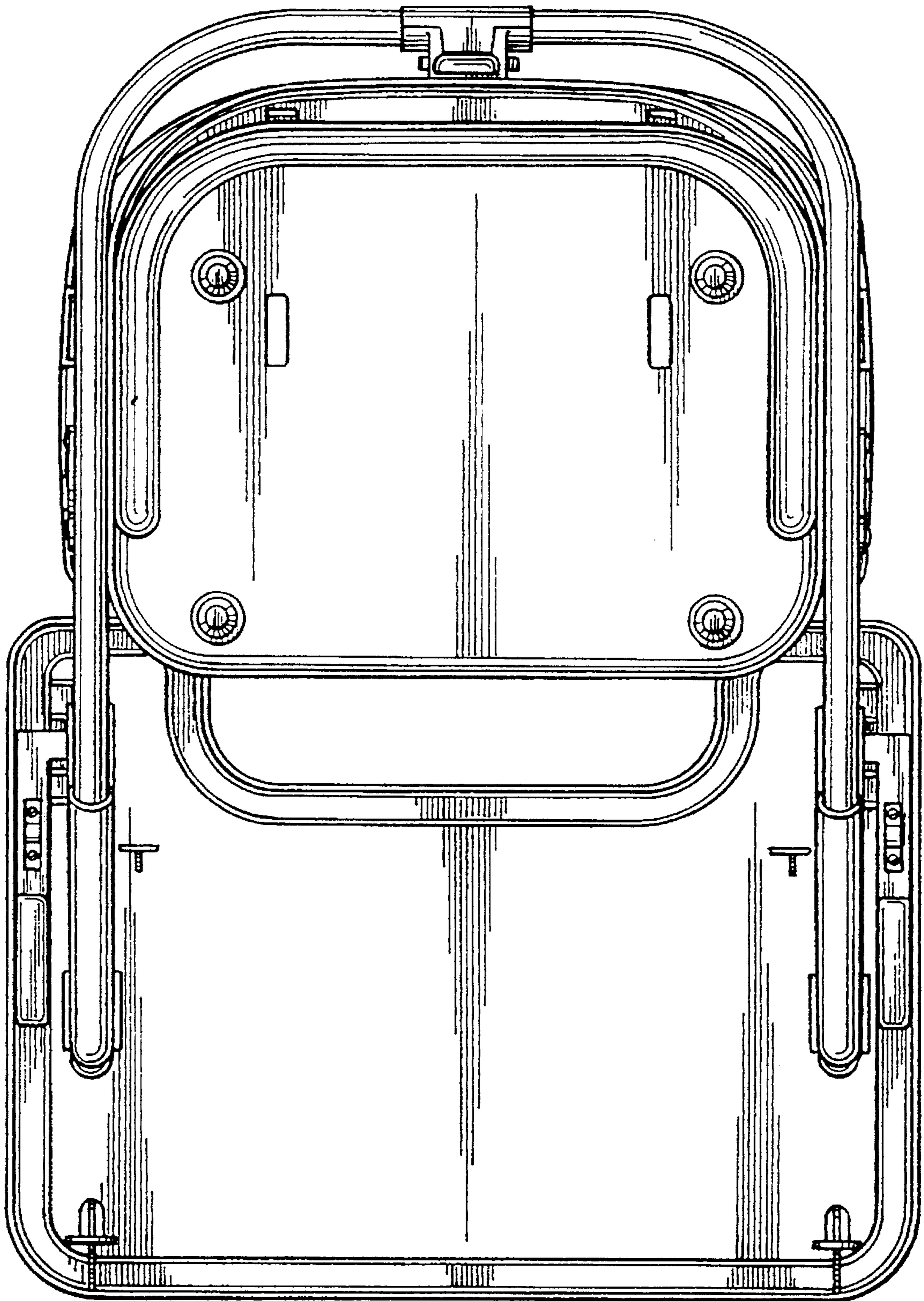

Fig. 6

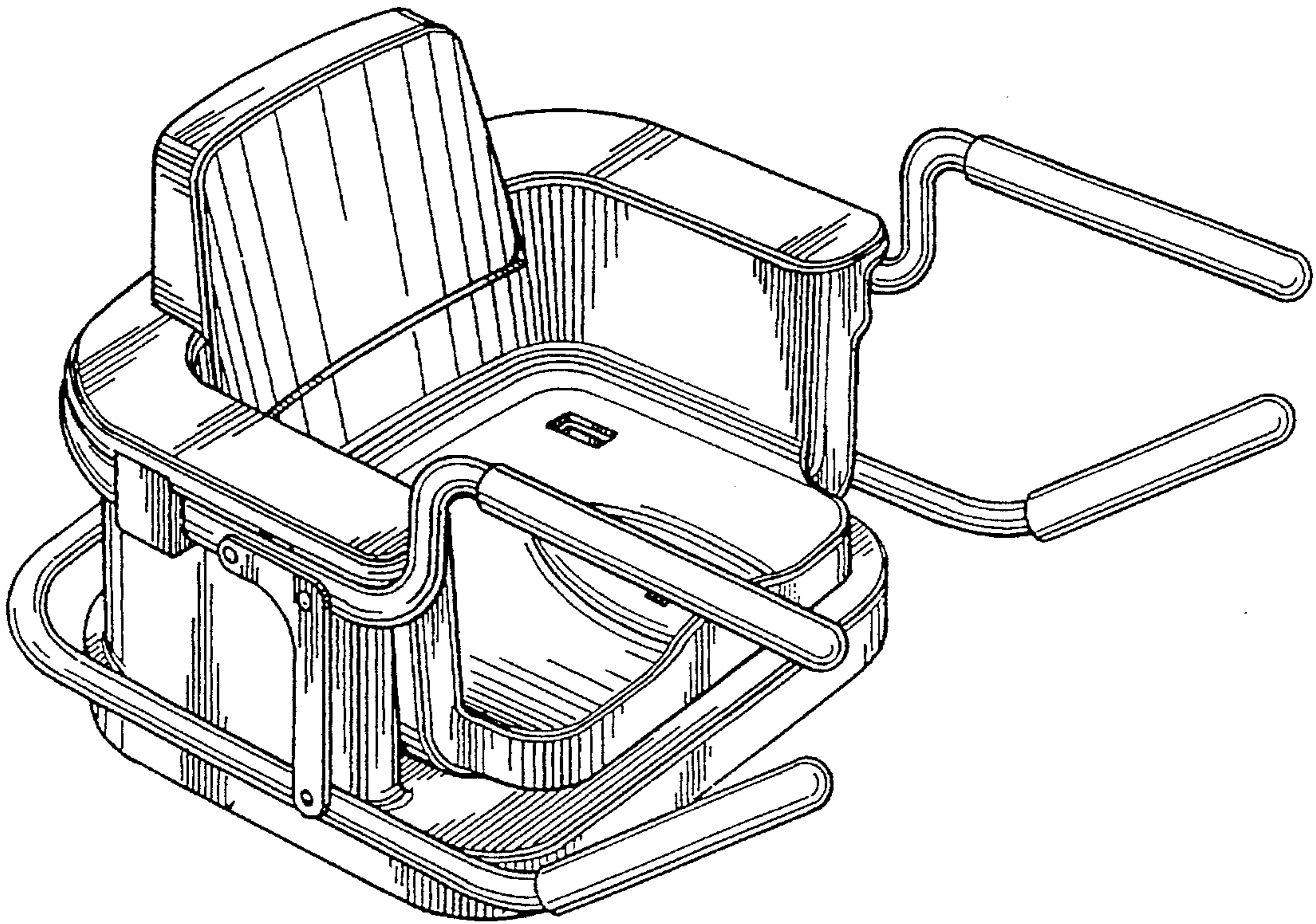

Fig. 7

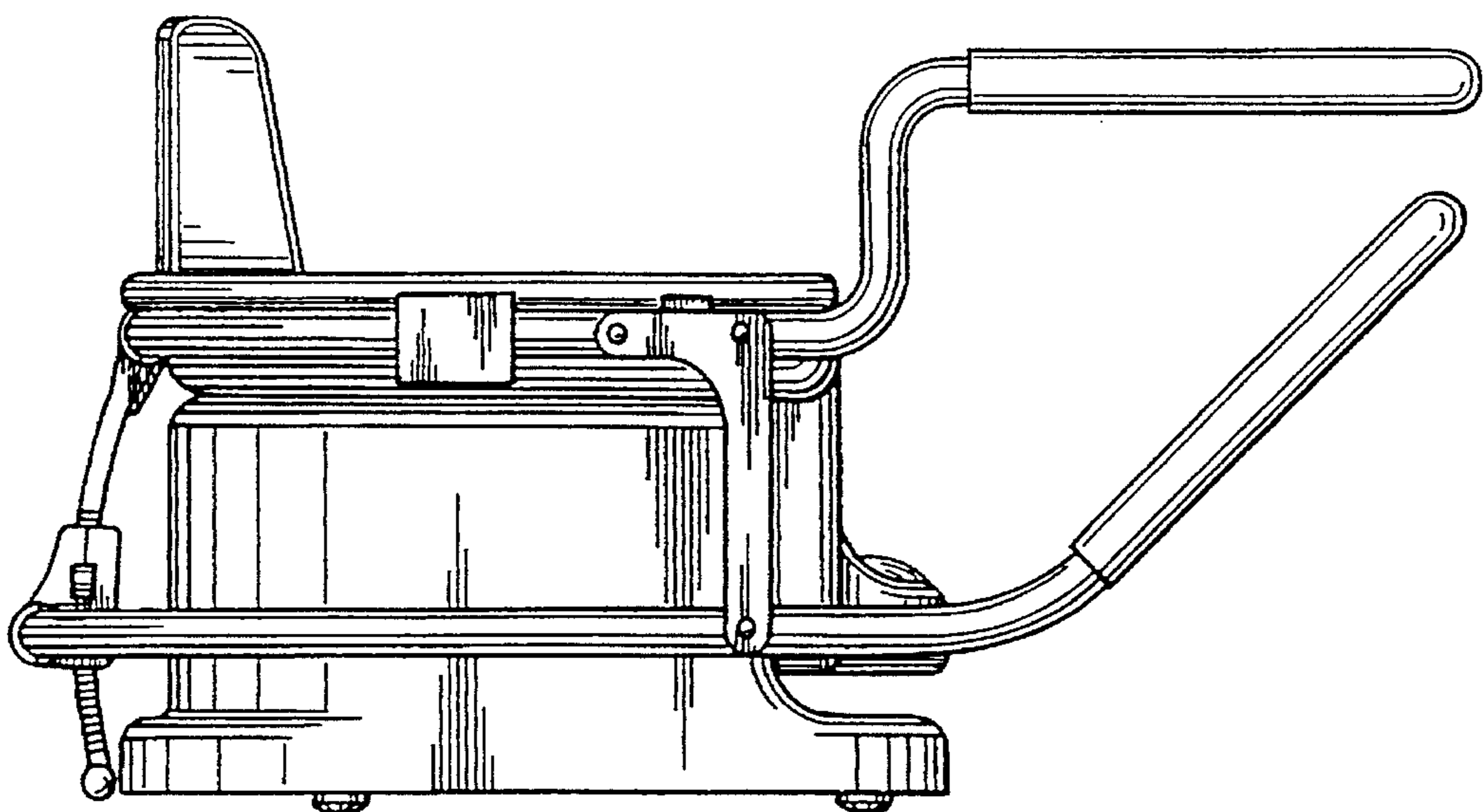

Fig. 8

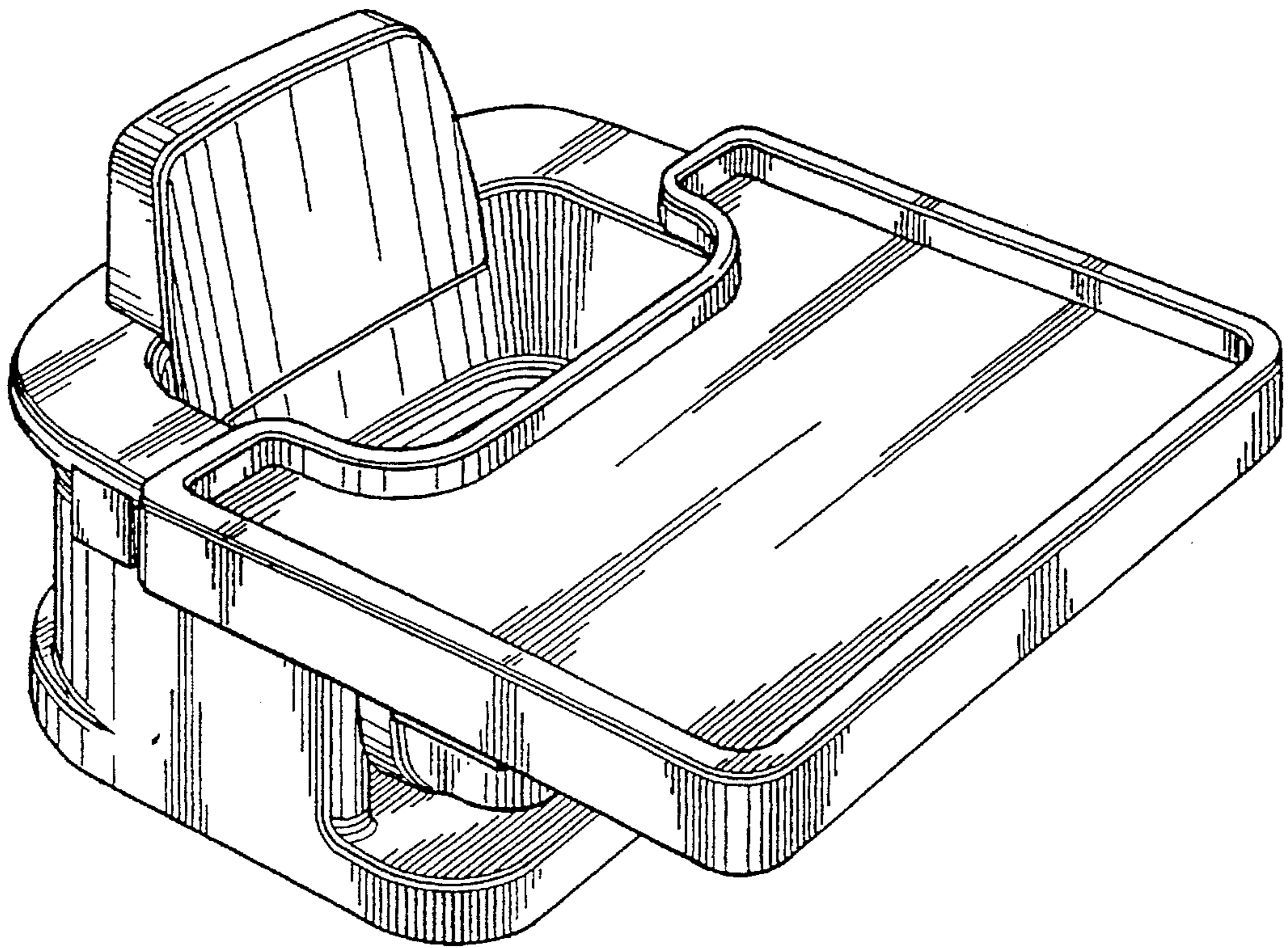

Fig. 9

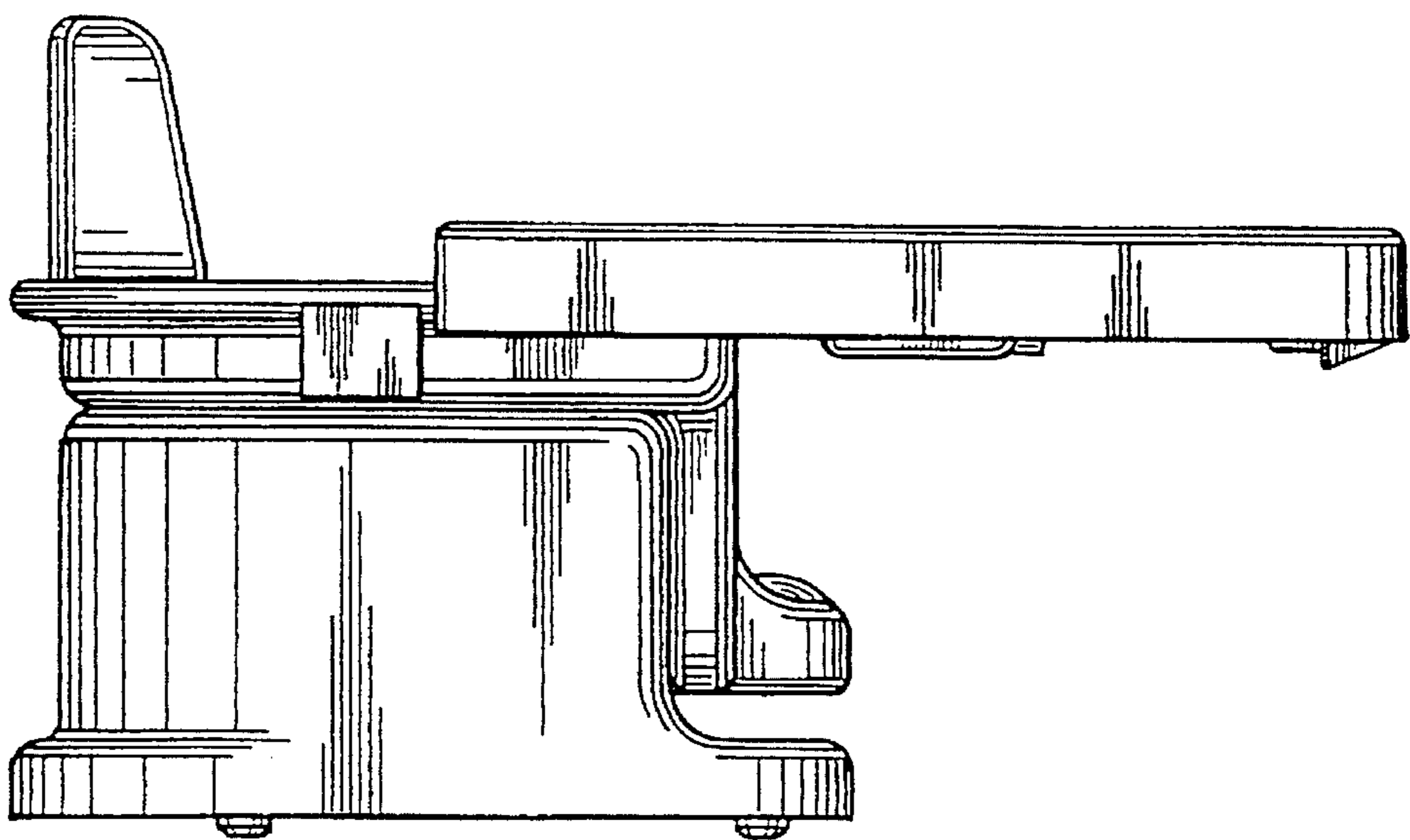

Fig. 10

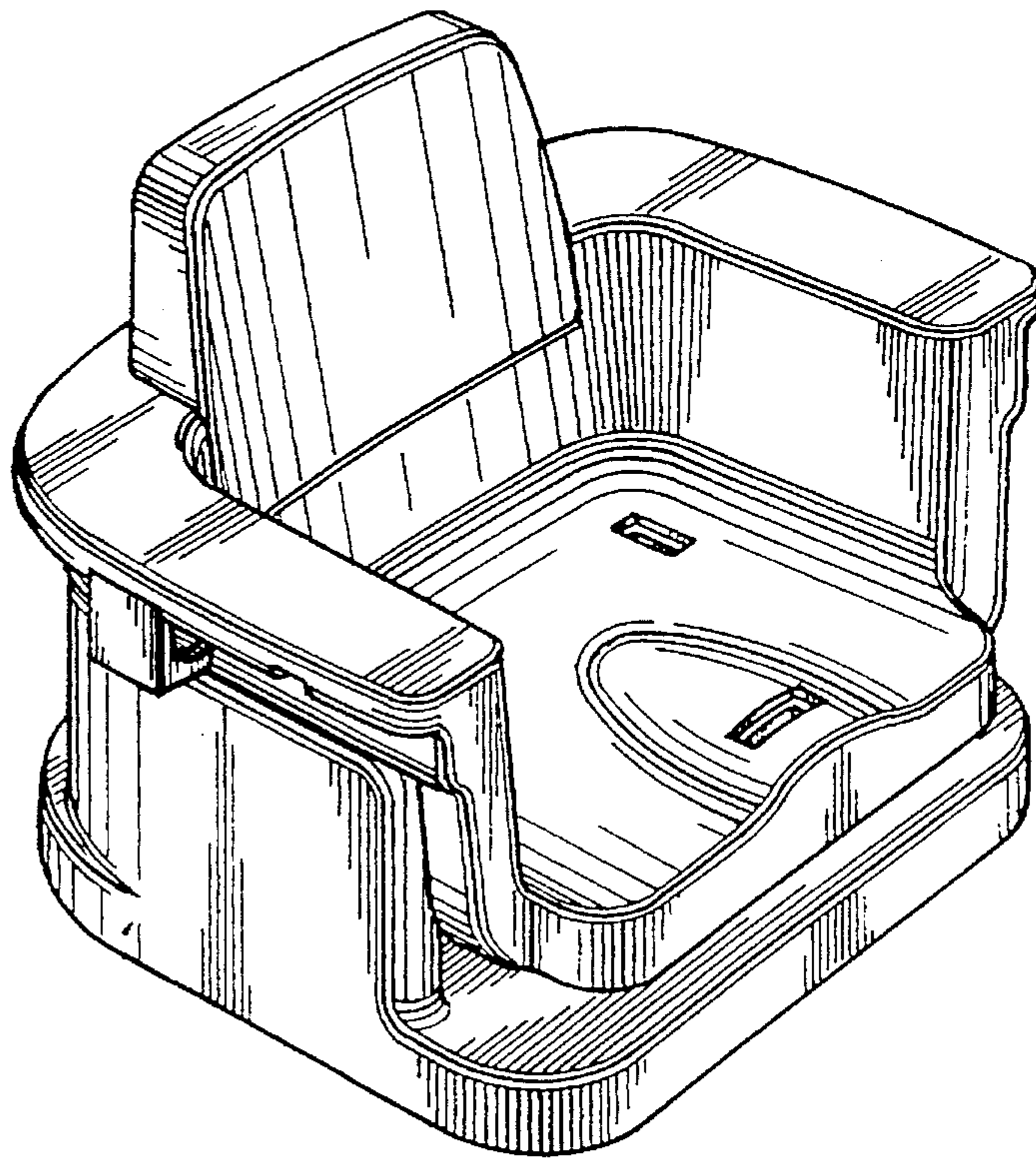

Fig. 11

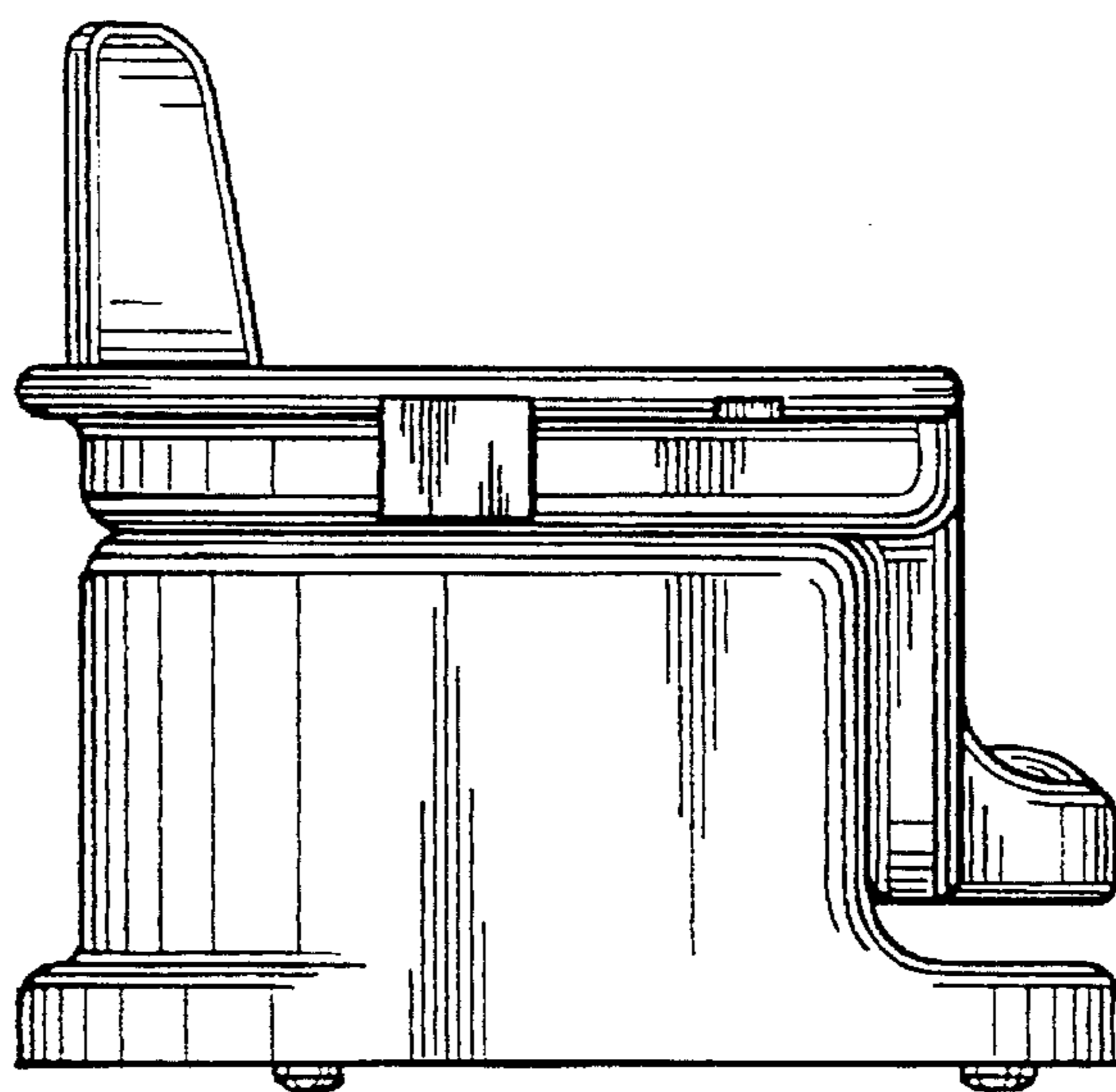

Fig. 12