



US00D373979S

United States Patent [19]

Starr et al.

[11] **Patent Number: Des. 373,979**

[45] **Date of Patent: **Sep. 24, 1996**

[54] **PICK-UP TRUCK BODY EXTERIOR SURFACE**

[75] Inventors: **John R. Starr**, Woodhaven; **Joseph A. Papai**, Bloomfield Township; **Dennis Myles**, West Bloomfield; **Ricardo Z. Aneiros**, Dearborn; **Trevor M. Creed**, West Bloomfield, all of Mich.

[73] Assignee: **Chrysler Corporation**, Auburn Hills, Mich.

[**] Term: **14 Years**

[21] Appl. No.: **23,246**

[22] Filed: **May 20, 1994**

[52] U.S. Cl. **D12/98**

[58] Field of Search **D12/98; 296/183**

[56] **References Cited**

U.S. PATENT DOCUMENTS

D. 313,379	1/1991	Machida et al.	D12/98
D. 316,987	5/1991	Machida et al.	D12/98
D. 336,266	6/1993	Hunter	D12/98
D. 352,485	11/1994	Creed et al.	D12/98
D. 357,213	4/1995	Hunter et al.	D12/98

OTHER PUBLICATIONS

Motor Trend, Sep. 1993, pp. 78 & 79, Dodge Ram T300 Pickup Truck.

Car & Driver, Dec. 1992, p. 113, Dodge Dakota Pickup Truck, Upper Right Side of Page.

1994 Dodge New Ram Pick-up Publication.

Hot Rod, Dec. 1985, pp. 64 & 65, Dodge Dakota Pickup Truck, Top of Page.

Primary Examiner—James M. Gandy
Attorney, Agent, or Firm—Mark P. Calcaterra

[57] **CLAIM**

The ornamental design for a pick-up truck body exterior surface, as shown and described.

DESCRIPTION

FIG. 1 is a front perspective view of a pick-up truck body exterior surface showing our new design;
 FIG. 2 is a rear perspective view of the pick-up truck body exterior surface shown in FIG. 1;
 FIG. 3 is a side view of the pick-up truck body exterior surface shown in FIG. 1, it being understood that the opposite side is substantially a mirror image thereof;
 FIG. 4 is a front view of the pick-up truck body exterior surface shown in FIG. 1;
 FIG. 5 is a rear view of the pick-up truck body exterior surface shown in FIG. 1; and,
 FIG. 6 is a side view of a pick-up truck body exterior surface showing a second embodiment of our new design, the sole difference being in the extended cab portion.
 The roof of the cab of both embodiments of the pick-up truck body exterior surface is understood to be plain and unornamented, and the interior of the bed thereof forms no part of the claimed design.
 The broken line showing of the tires and wheels in the drawing is for illustrative purposes only and forms no part of the claimed design.

1 Claim, 5 Drawing Sheets

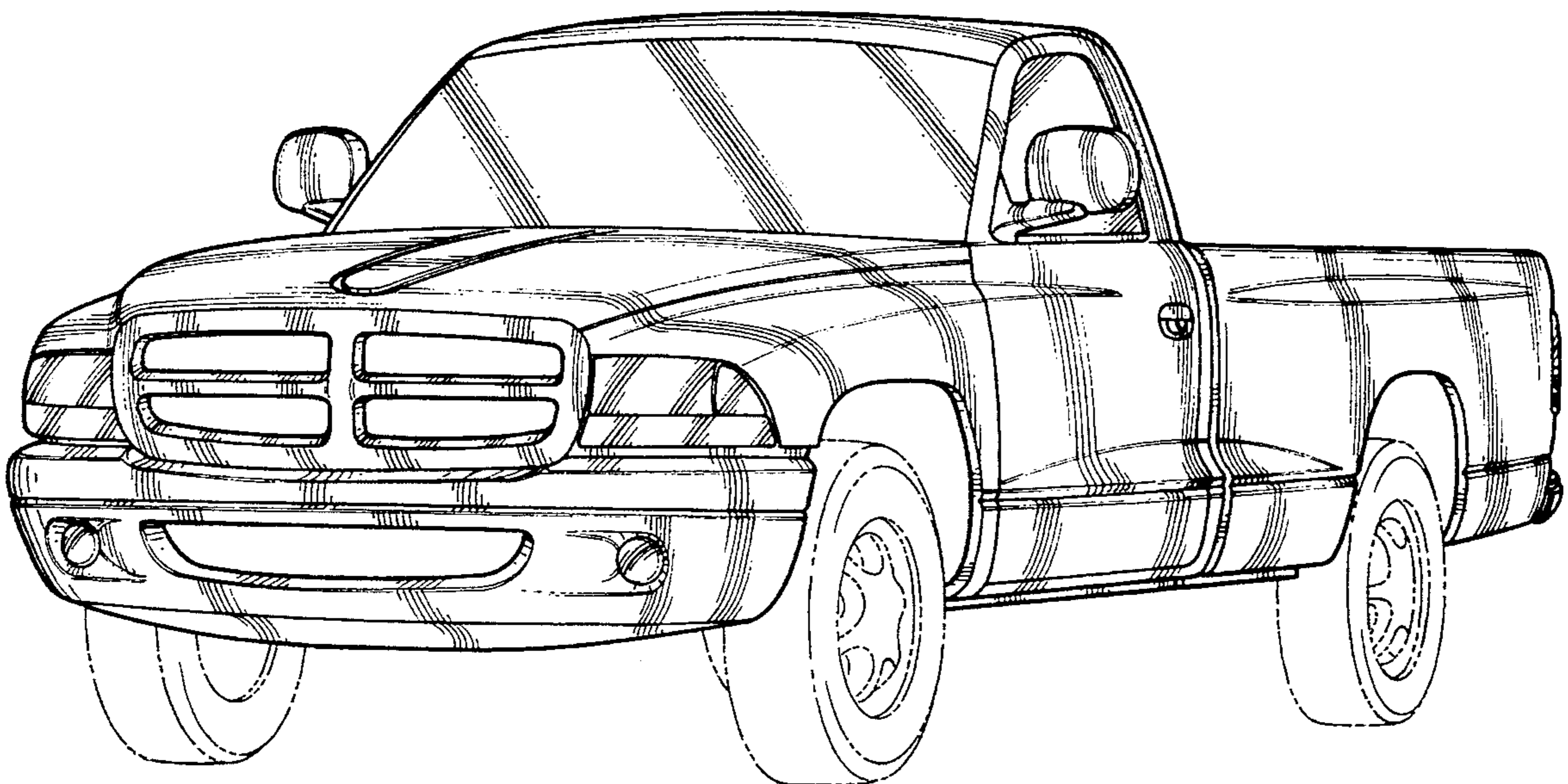

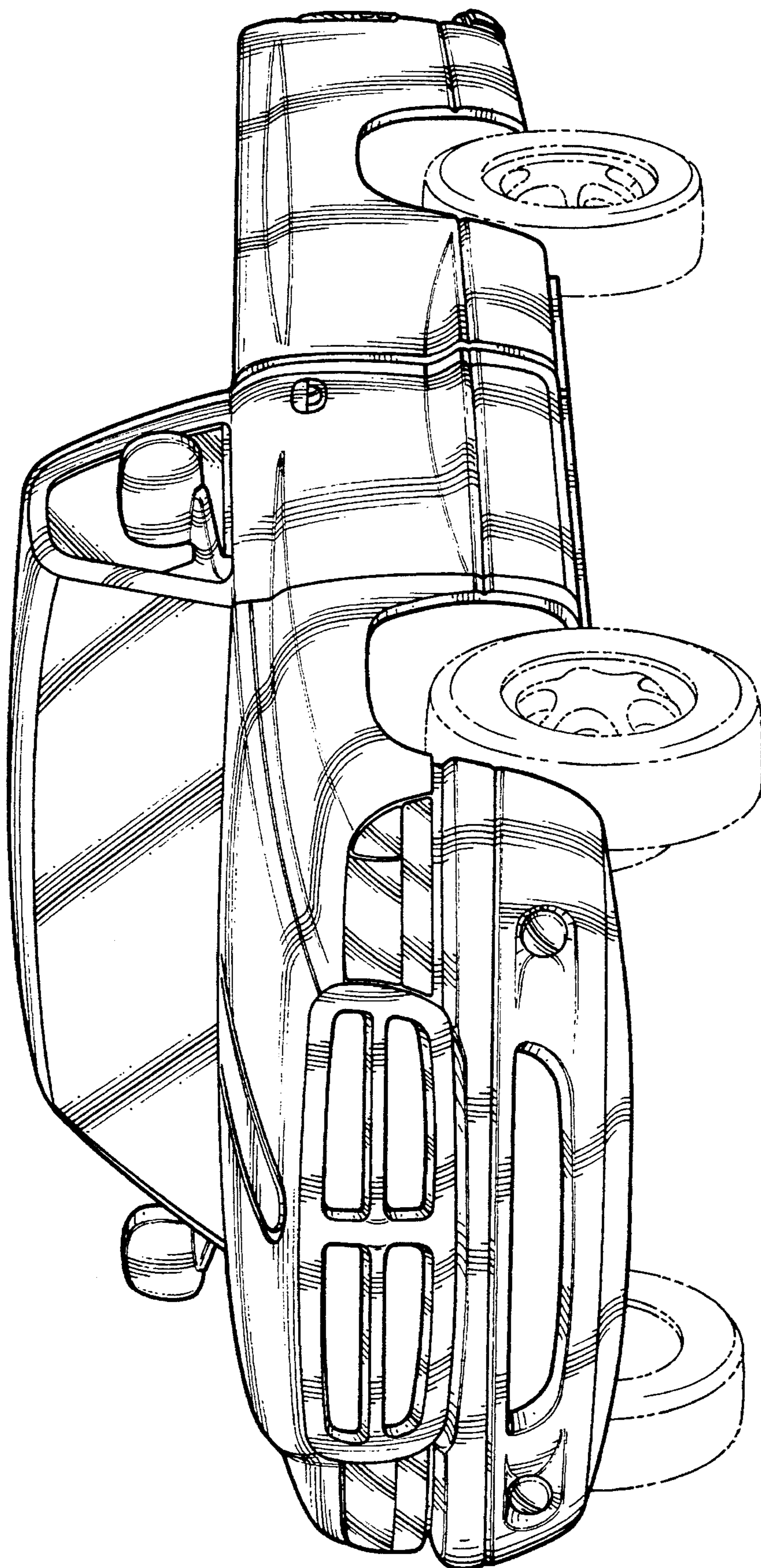

Fig - 1

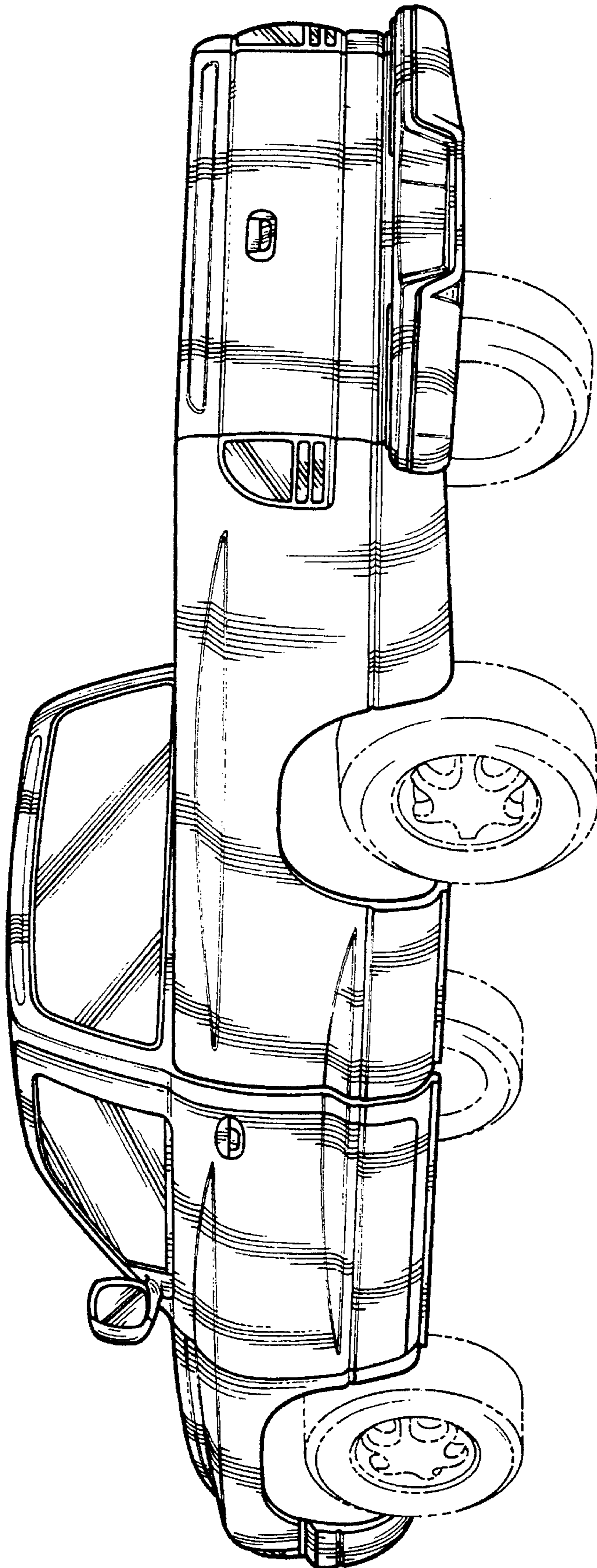

Fig - 2

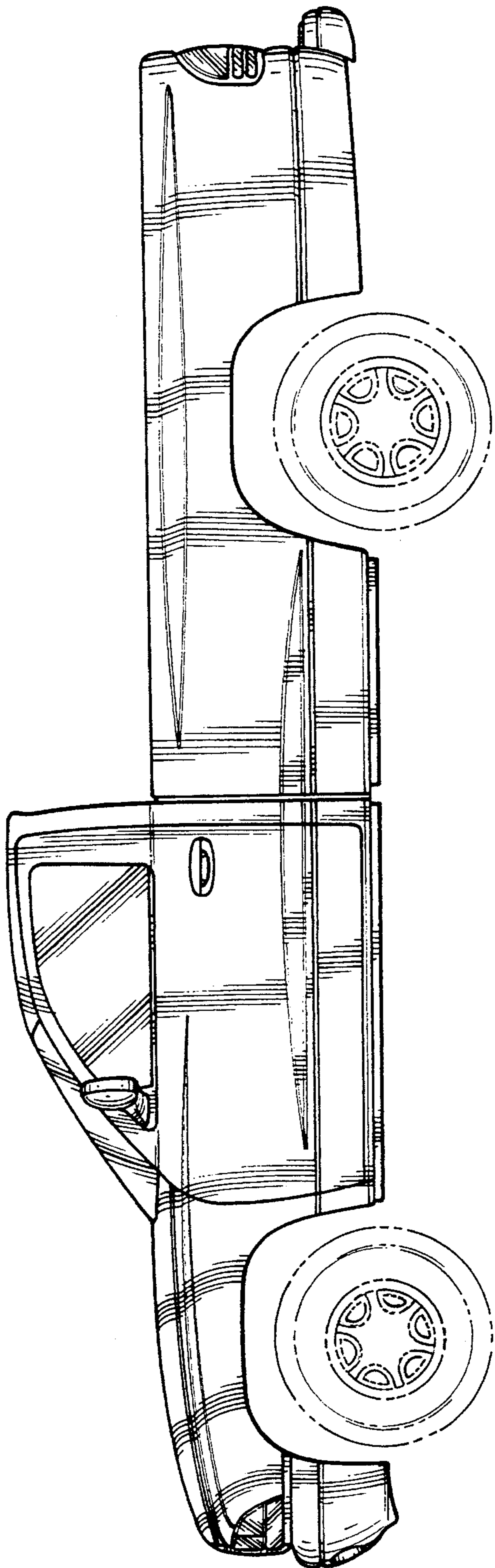

Fig - 3

Fig - 4

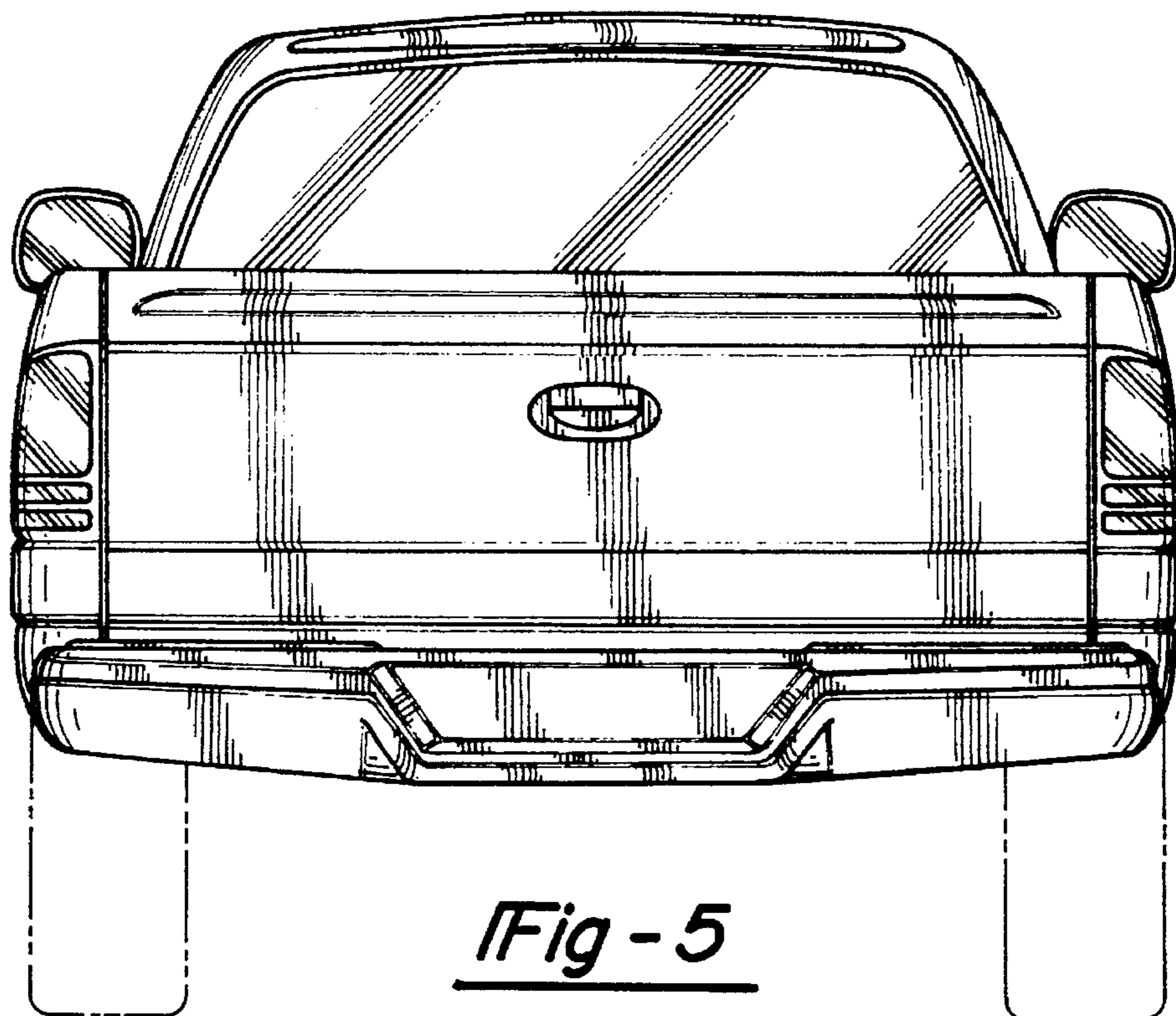
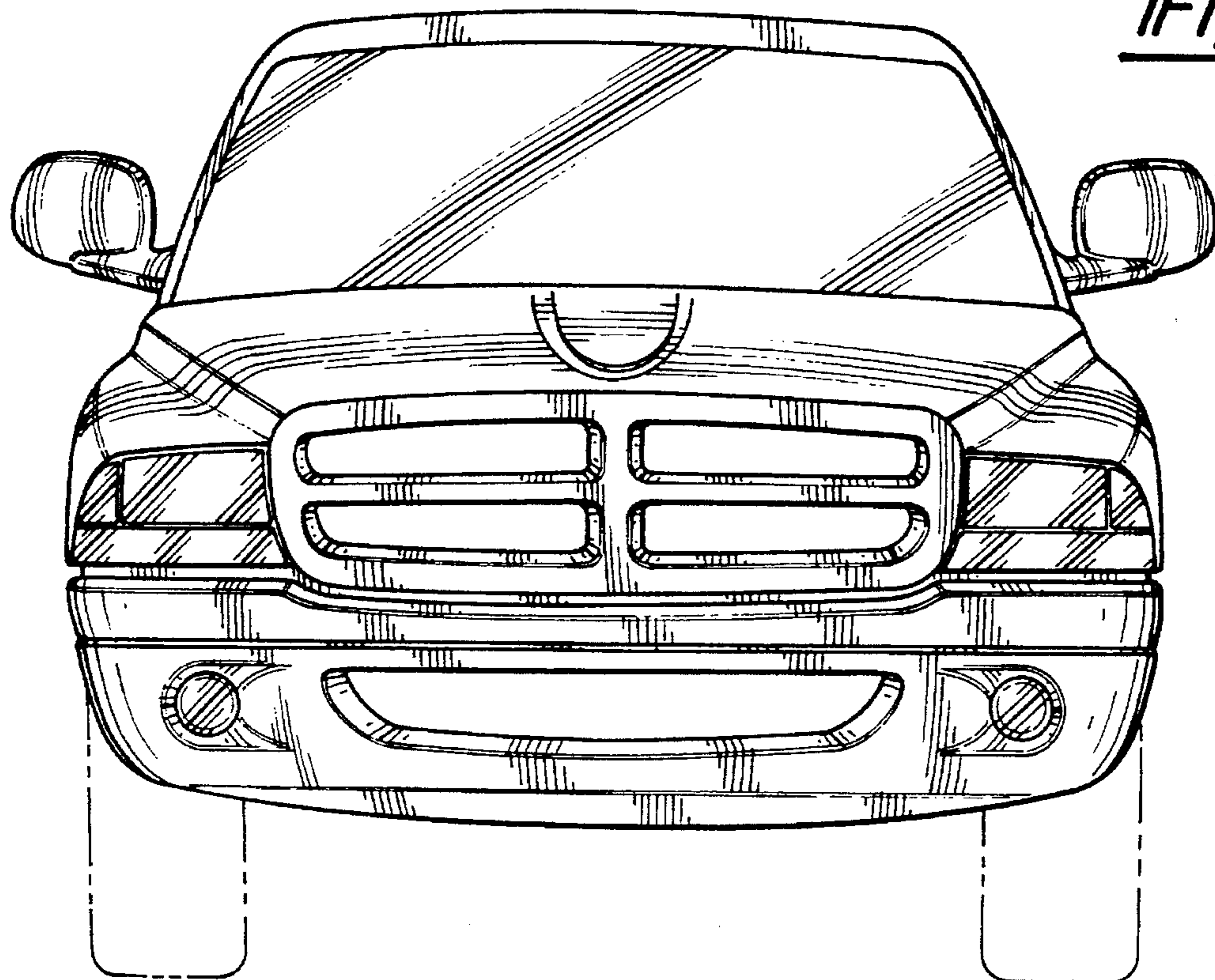

Fig - 5

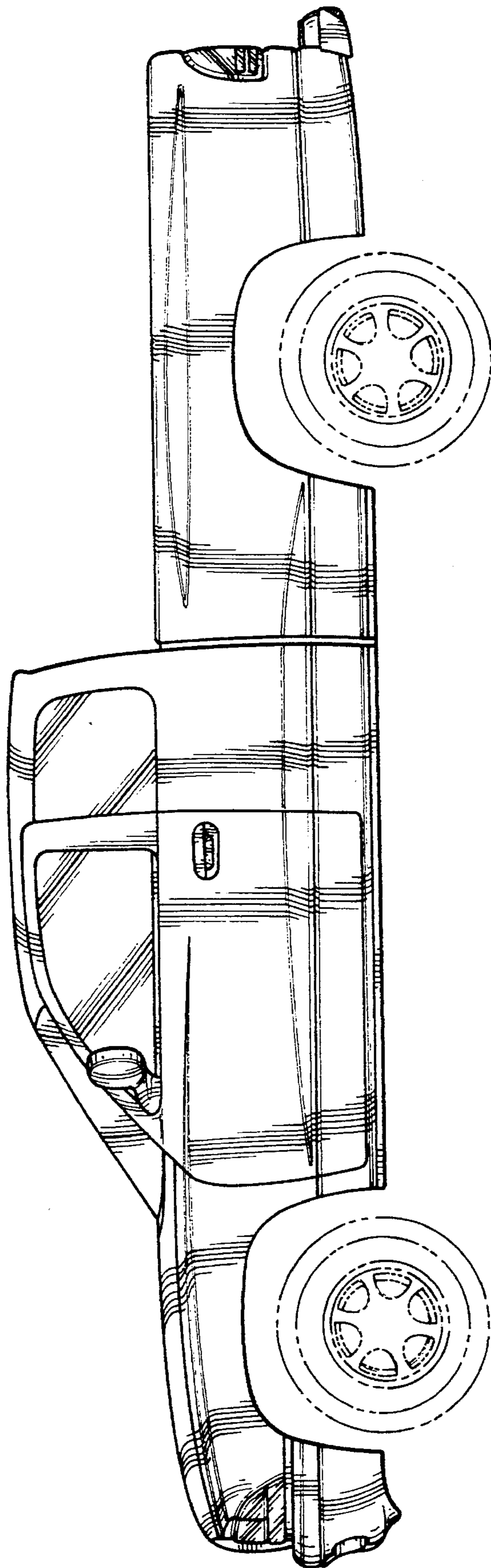

Fig - 6