



US00D373864S

United States Patent [19]

Pearce

[11] Patent Number: **Des. 373,864**

[45] Date of Patent: ****Sep. 17, 1996**

[54] **DROP TRAY FOR INJECTION MOLDED PARTS**

[76] Inventor: **Woodrow W. Pearce**, 1601 Puebla Dr., Glendale, Calif. 91207

[**] Term: **14 Years**

[21] Appl. No.: **37,374**

[22] Filed: **Apr. 11, 1995**

[52] U.S. Cl. **D32/53.1**

[58] Field of Search D32/53.1; 15/257.06; 206/203; 220/570, 571, 572, DIG. 12, DIG. 13

[56] **References Cited**

U.S. PATENT DOCUMENTS

D. 286,458	10/1986	Pages	D32/53.1
D. 332,683	1/1993	Adolf	D32/53.1
2,798,239	7/1957	Freund	15/257.06
3,157,902	11/1964	Hardwick	15/257.06
3,790,201	2/1974	Morsilli	15/257.06 X

Primary Examiner—Antoine Duval Davis
Attorney, Agent, or Firm—Christie, Parker & Hale, LLP

[57] **CLAIM**

The ornamental design for a drop tray for injection molded parts, as shown and described.

DESCRIPTION

FIG. 1 is a front perspective view of an drop tray for injection molded parts showing my new design;

FIG. 2 is a top plan view thereof;

FIG. 3 is a front elevational view thereof;

FIG. 4 is a rear elevational view thereof;

FIG. 5 is a bottom plan view thereof; and,

FIG. 6 is a right side elevational view, the left side being a mirror image thereof.

Portions of the chain supports are not shown for ease of illustration.

1 Claim, 4 Drawing Sheets

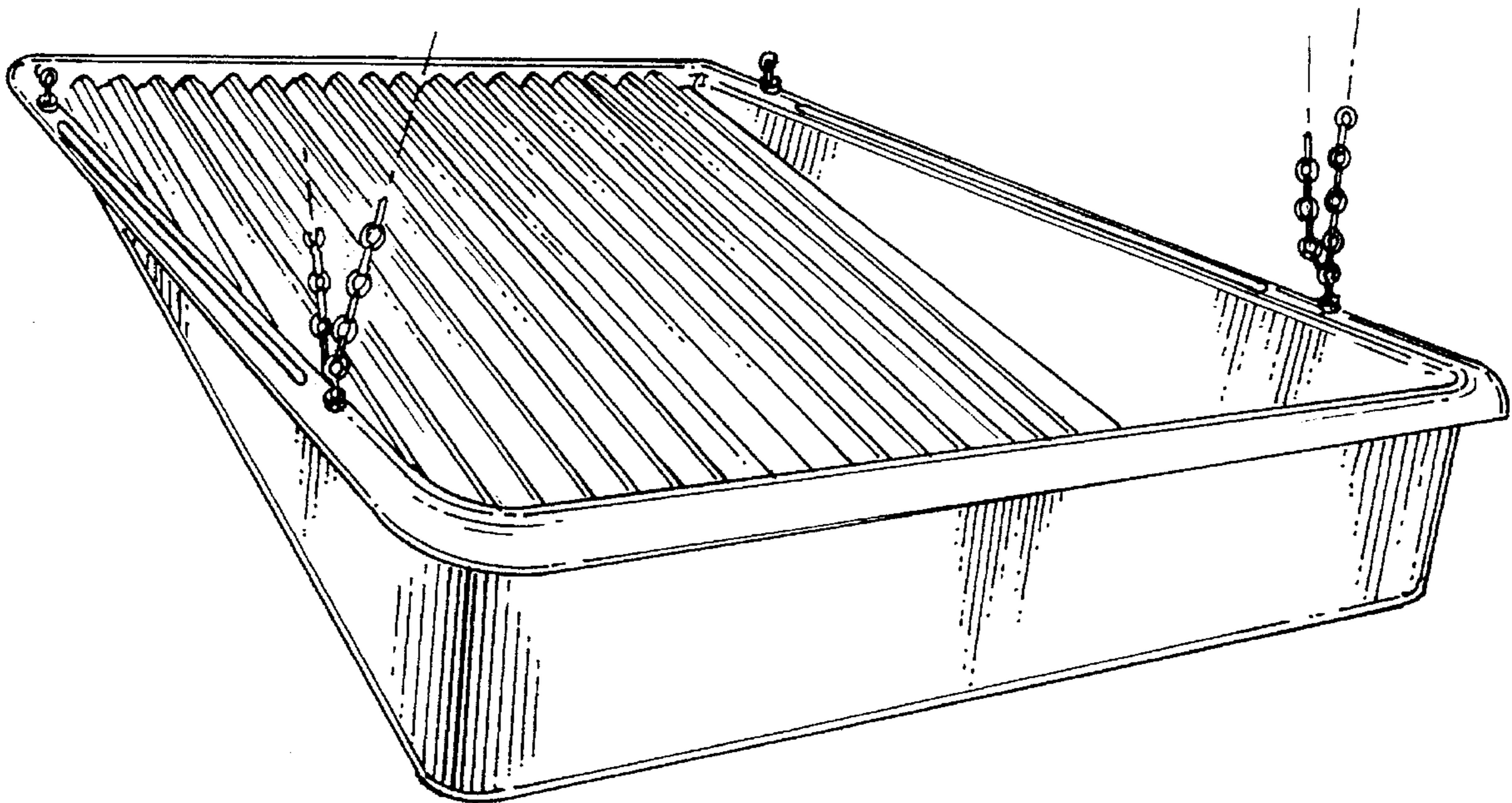

Fig. 1

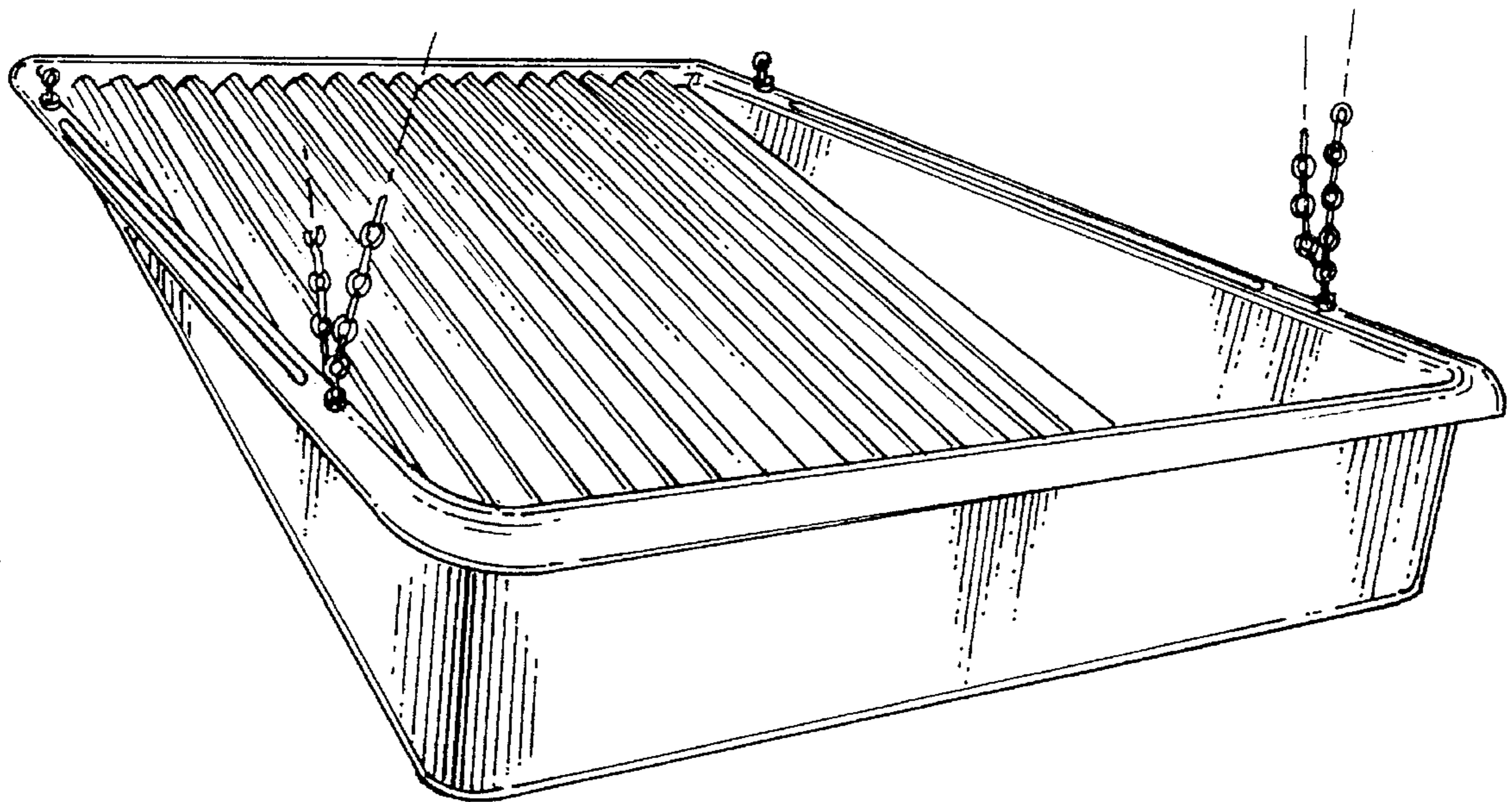

Fig. 2

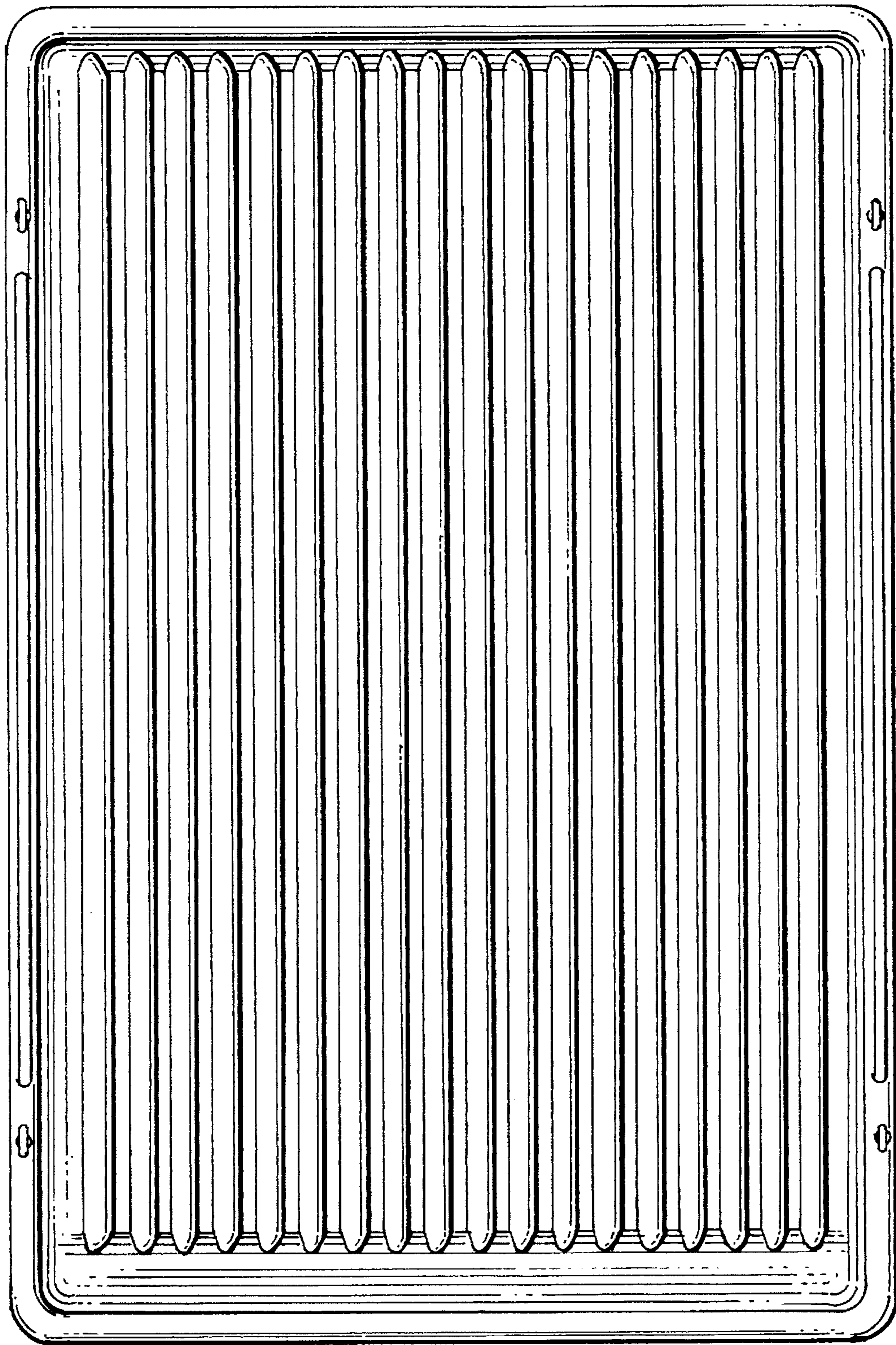

Fig. 3

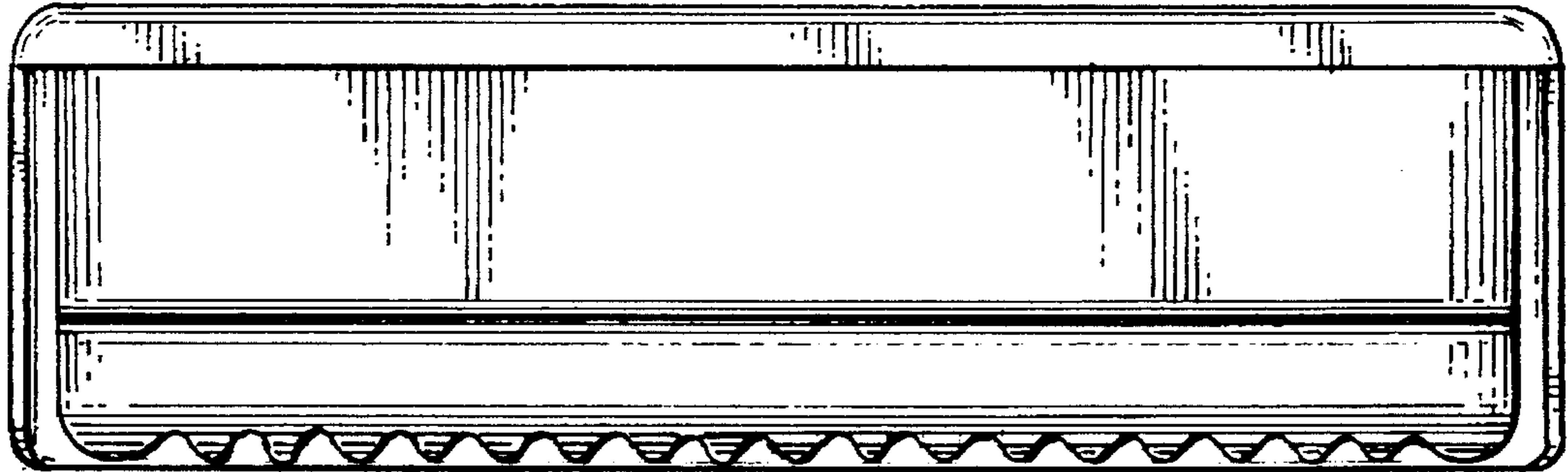
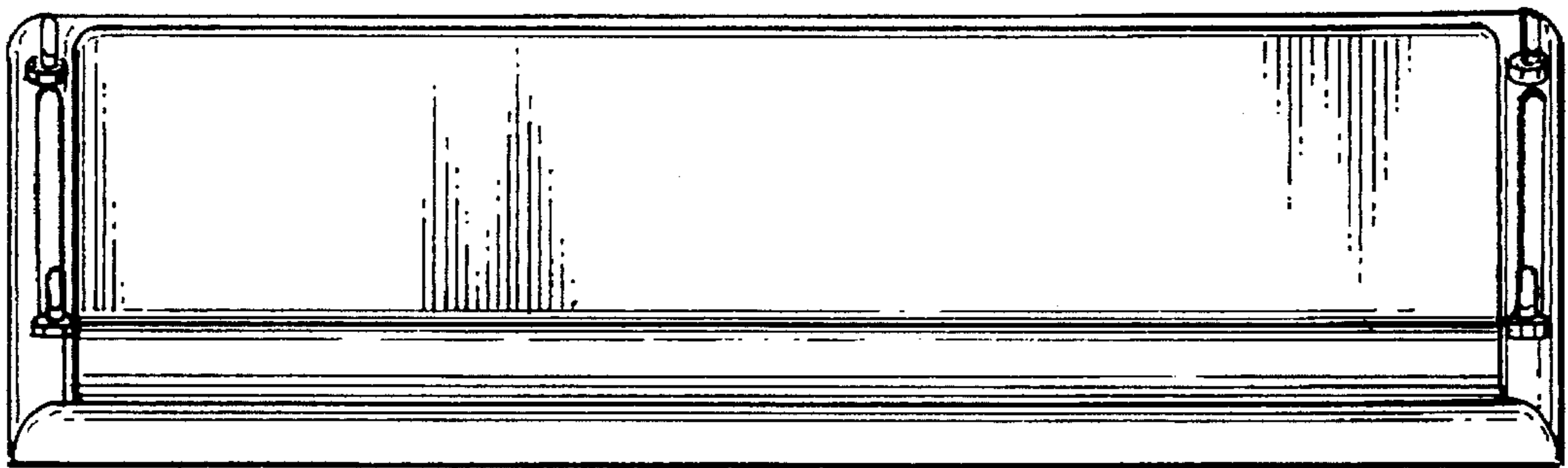

Fig. 4



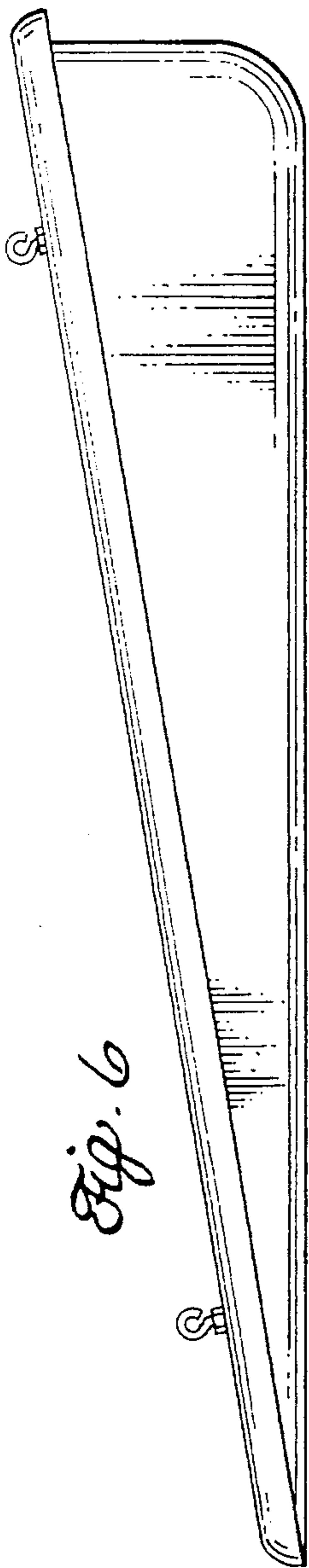

Fig. 6

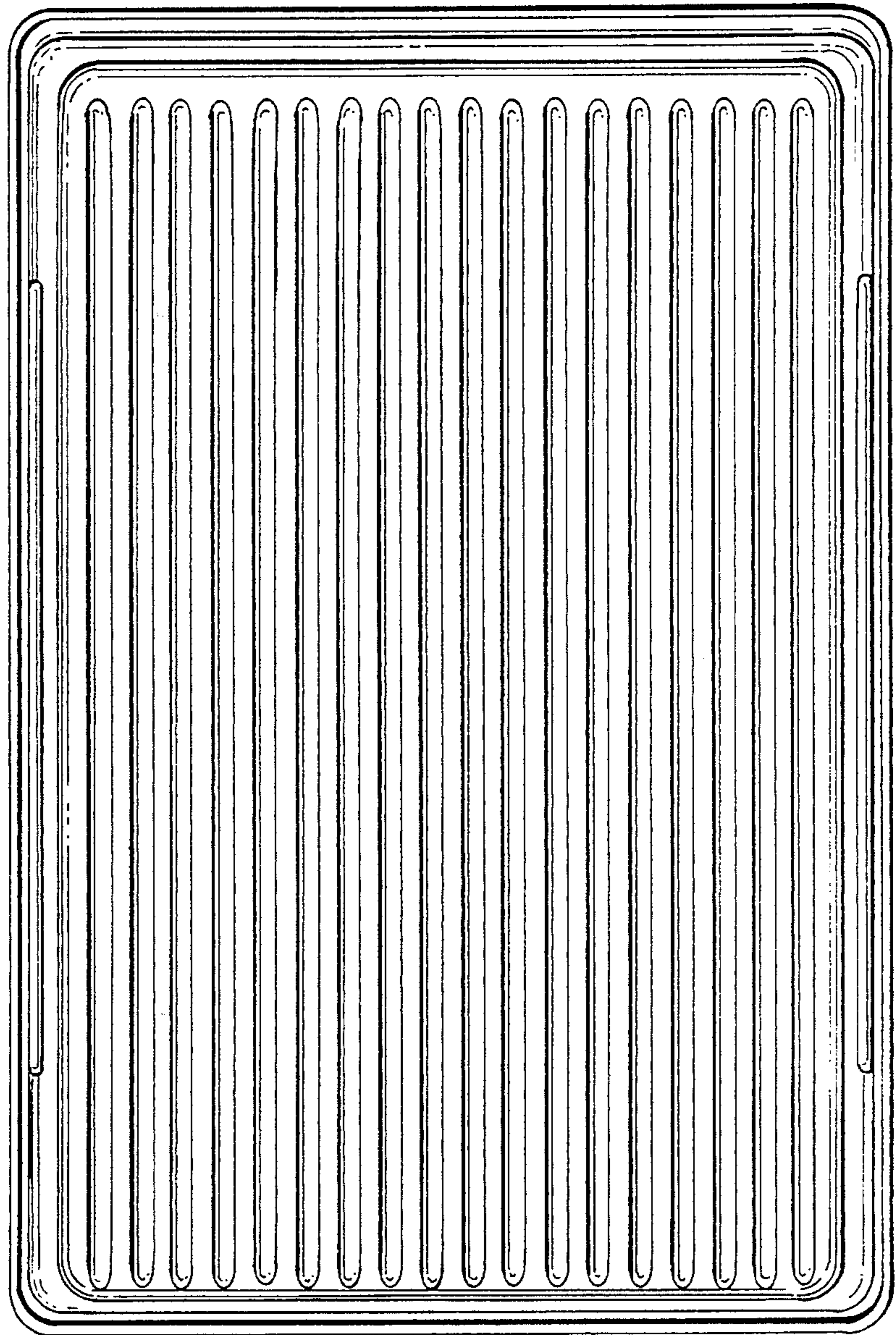

Fig. 5