



US00D373752S

# United States Patent [19]

McCormack

[11] Patent Number: **Des. 373,752**

[45] Date of Patent: **\*\*Sep. 17, 1996**

[54] TAILGATE

[75] Inventor: **John E. McCormack**, Newmarket, Canada

[73] Assignee: **Atoma International Inc.**, Newmarket

[\*\*] Term: **14 Years**

[21] Appl. No.: **38,285**

[22] Filed: **May 1, 1995**

[52] U.S. Cl. .... **D12/196**

[58] Field of Search ..... D12/196; 296/50, 296/57.1, 180.1

[56] **References Cited**

**U.S. PATENT DOCUMENTS**

D. 250,014	10/1978	Jensen	.....	D12/196
D. 289,516	4/1987	Watts	.....	D12/196
4,063,772	12/1977	Kincaid	.....	296/1 S
4,165,118	8/1979	Jensen	.....	296/50

4,353,589	10/1982	Hartberg	.....	296/50
4,743,058	5/1988	Fedigo	.....	296/1 S
4,861,093	8/1989	Chapman	.....	296/180.1
4,902,066	2/1990	Norman	.....	296/180.1
5,273,339	12/1993	Flynn	.....	296/180.1

*Primary Examiner*—James M. Gandy  
*Attorney, Agent, or Firm*—Mark B. Eisen

[57] **CLAIM**

The ornamental design for a tailgate, as shown.

**DESCRIPTION**

FIG. 1 is a perspective view of the tailgate;  
FIG. 2 is a rear elevation;  
FIG. 3 is a top plan view;  
FIG. 4 is a side elevation;  
FIG. 5 is a side elevation taken opposite FIG. 4;  
FIG. 6 is a front elevation; and,  
FIG. 7 is a bottom plan view.

**1 Claim, 3 Drawing Sheets**

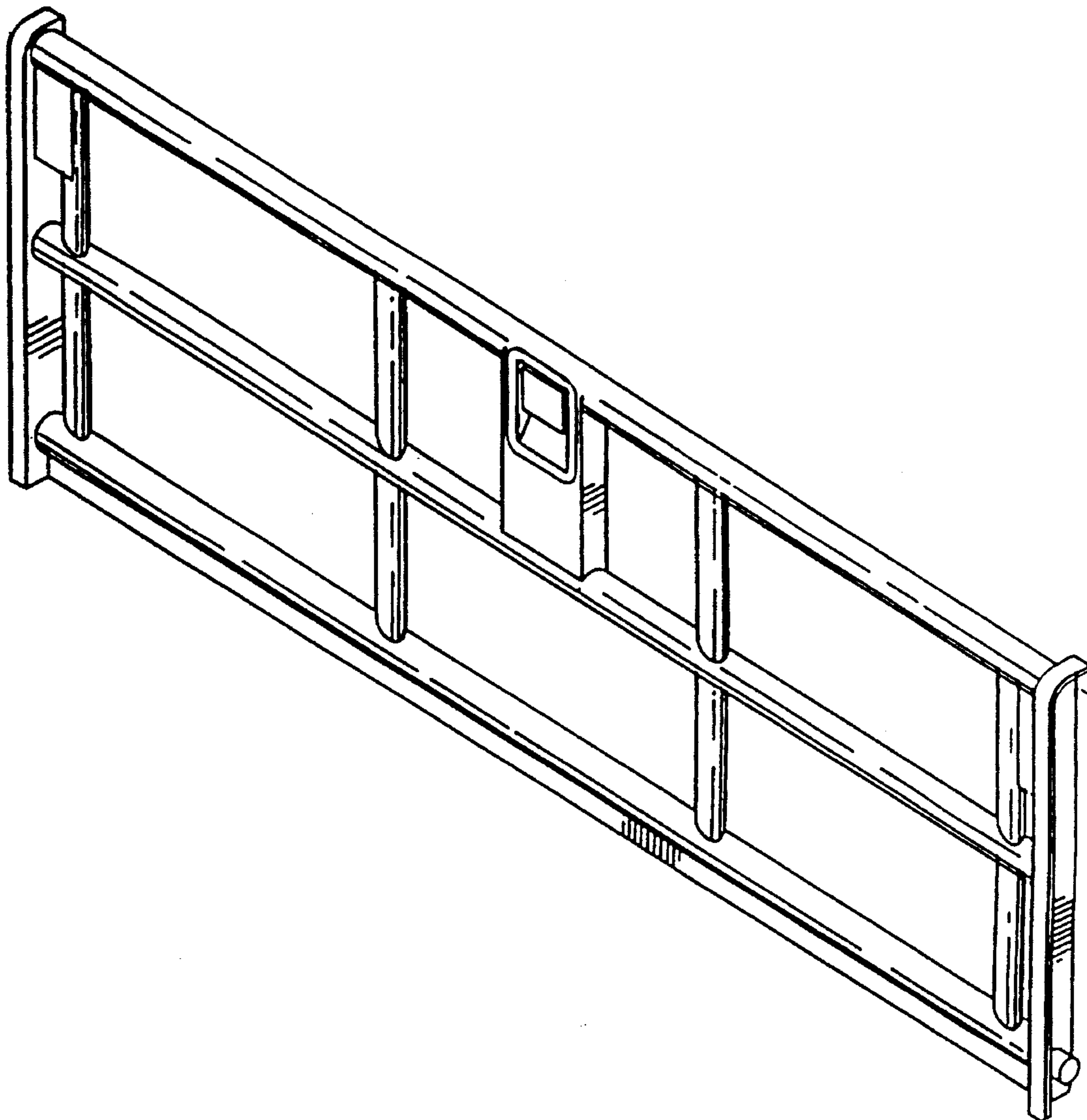

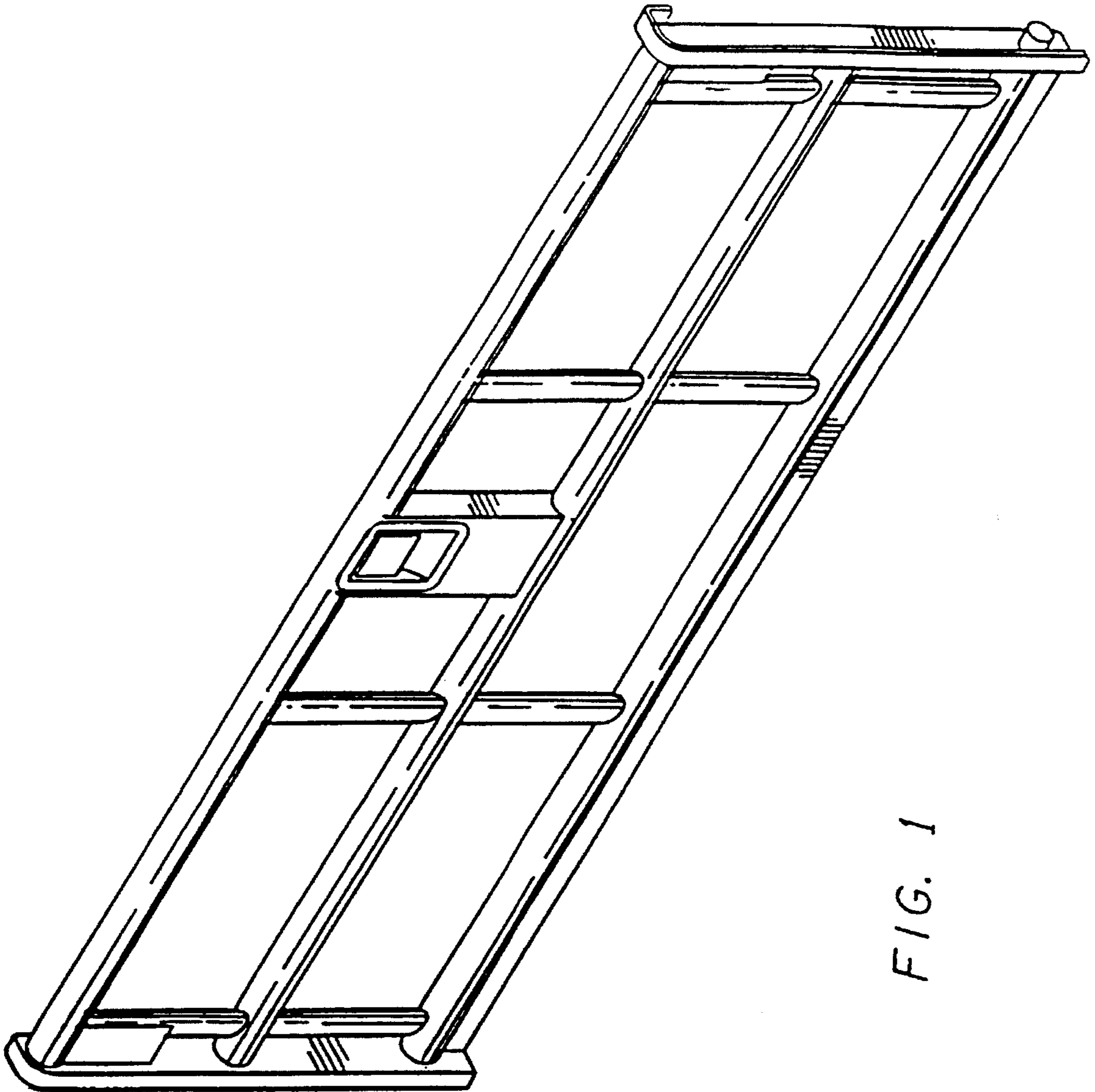

FIG. 1

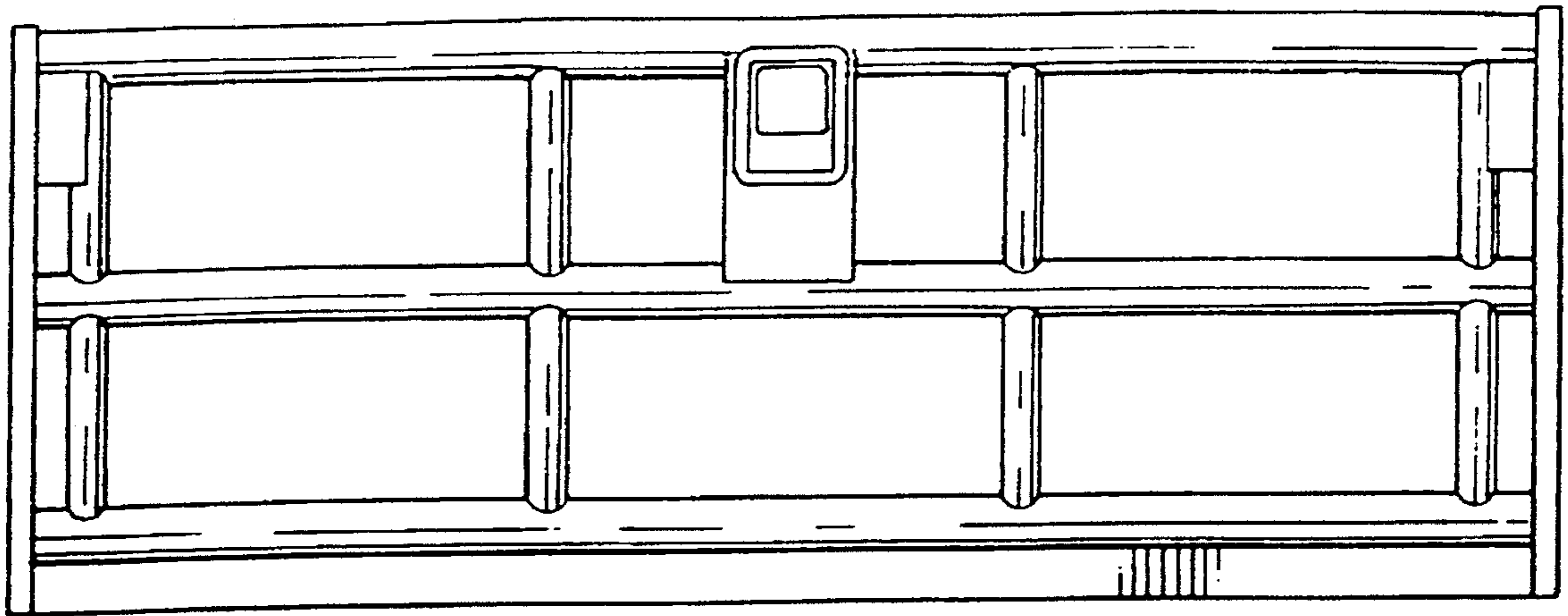

FIG. 2

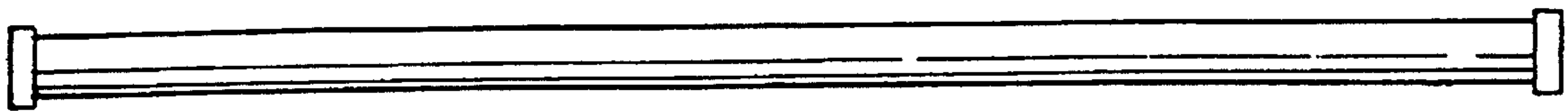

FIG. 3



FIG. 4



FIG. 5

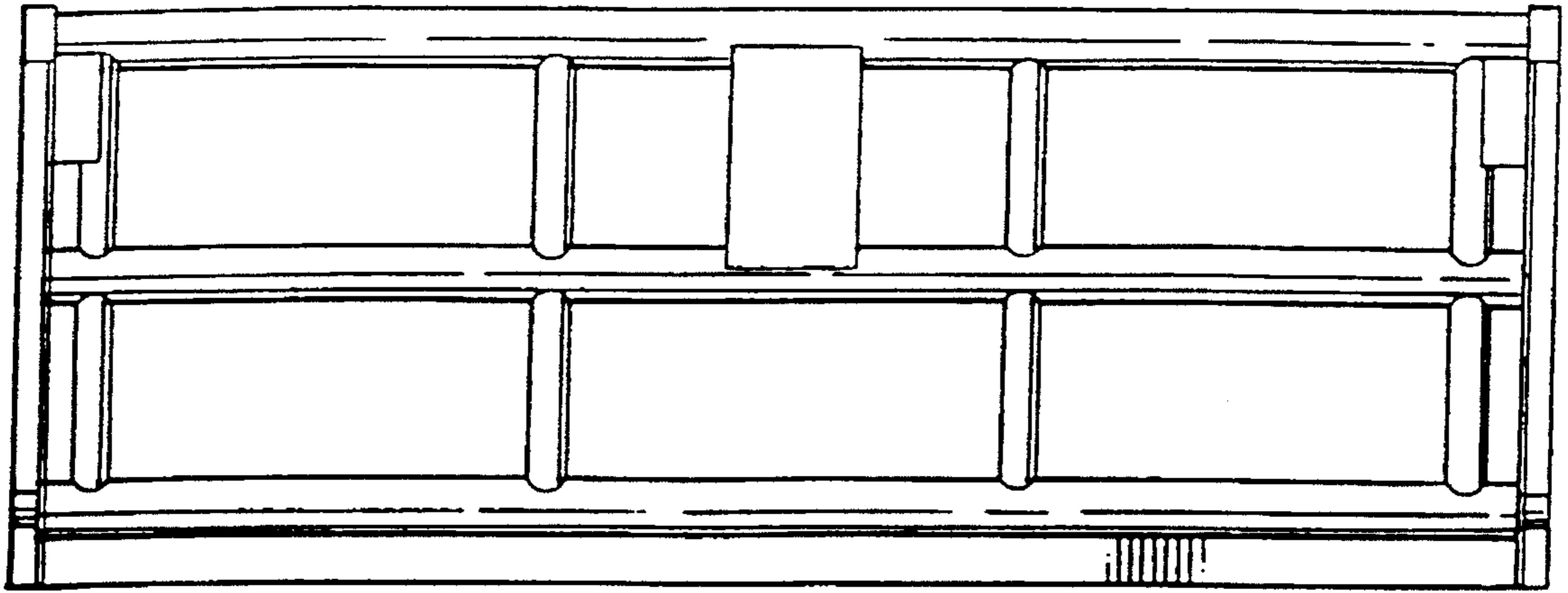

FIG. 6

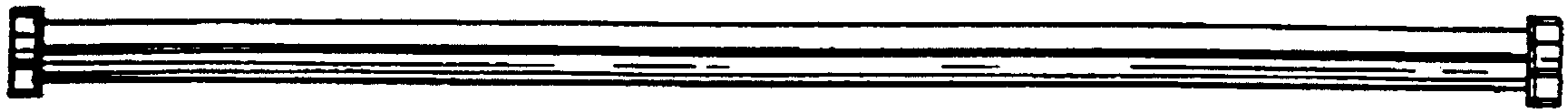

FIG. 7