



US00D373720S

United States Patent [19]

Hirano et al.

[11] Patent Number: **Des. 373,720**

[45] Date of Patent: ****Sep. 17, 1996**

[54] **HINGE JOINT FOR FRAME OF ROLLABLE CART**

[75] Inventors: **Seiji Hirano; Shuji Yoshino**, both of Shizuoka, Japan

[73] Assignee: **Yazaki Industrial Chemical Co., Ltd.**, Shizuoka, Japan

[**] Term: **14 Years**

[21] Appl. No.: **27,443**

[22] Filed: **Aug. 22, 1994**

[52] U.S. Cl. **D8/382**

[58] Field of Search D8/323, 382, 373; 403/49, 70, 112, 113, 150; 211/168, 182, 187; 248/230, 124; 285/420

[56] **References Cited**

U.S. PATENT DOCUMENTS

D. 355,843	2/1995	Kuwata	D8/382
920,962	5/1909	Repke	211/47
1,308,630	7/1919	Hatch	403/112 X

2,839,320	6/1958	Hill	D8/382 X
3,179,212	4/1965	Gostling	211/187 X
4,767,232	8/1988	Francis	403/113 X
4,796,324	1/1989	Sartori	403/113 X

Primary Examiner—Paula A. Mortimer
Attorney, Agent, or Firm—Smith-Hill and Bedell

[57] **CLAIM**

The ornamental design for a hinge joint for frame of rollable cart, as shown and described.

DESCRIPTION

FIG. 1 is a perspective view of a hinge joint for frame of rollable cart showing our new design; FIG. 2 is a front elevational view thereof; FIG. 3 is a rear elevational view thereof; FIG. 4 is a top plan view thereof; FIG. 5 is a right side elevational view thereof; FIG. 6 is a left side elevational view thereof; and, FIG. 7 is a front perspective view in use thereof, the broken line showing of the frame members is for illustrative purposes only and forms no part of the claimed design.

1 Claim, 3 Drawing Sheets

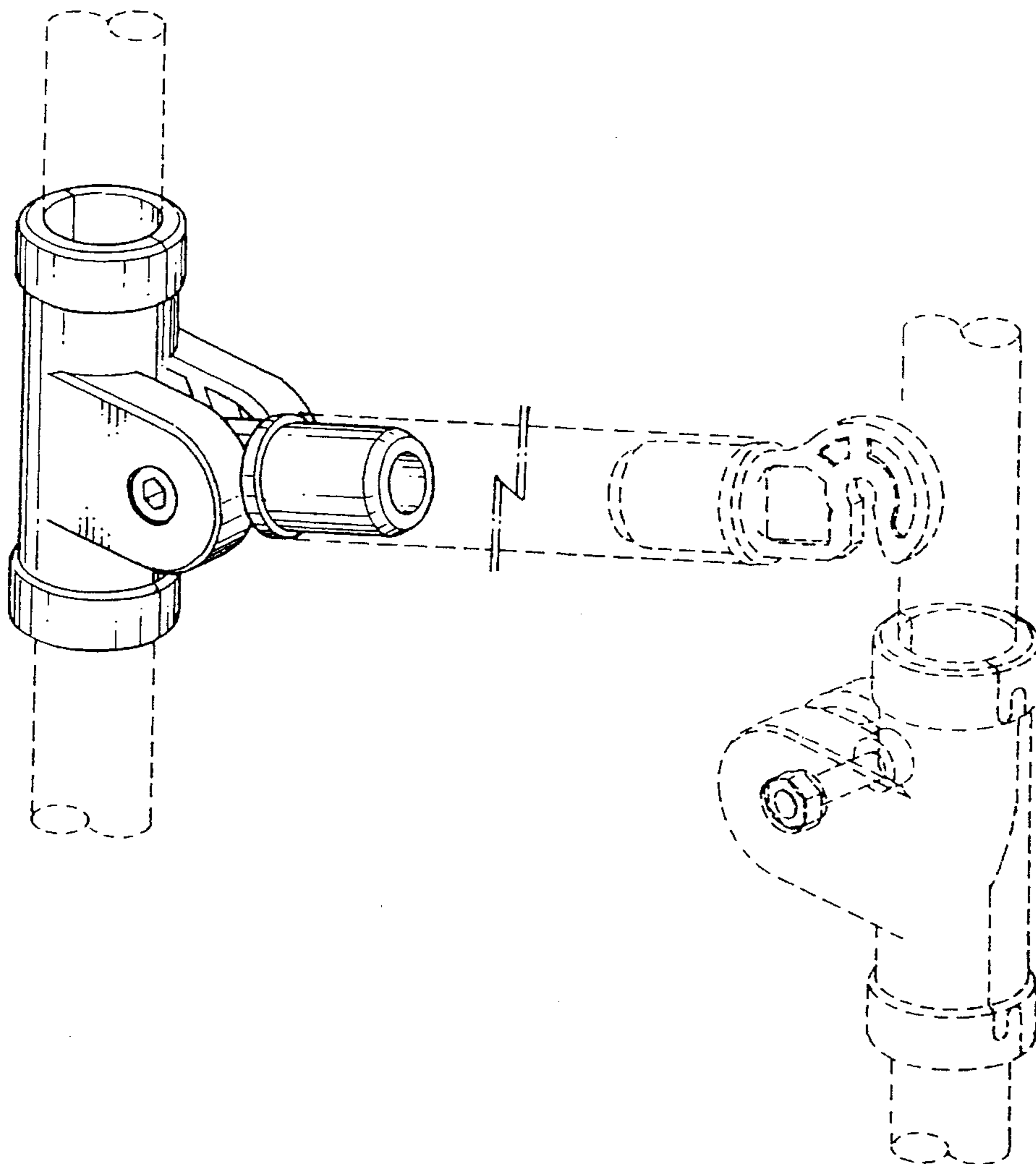

FIG. 1

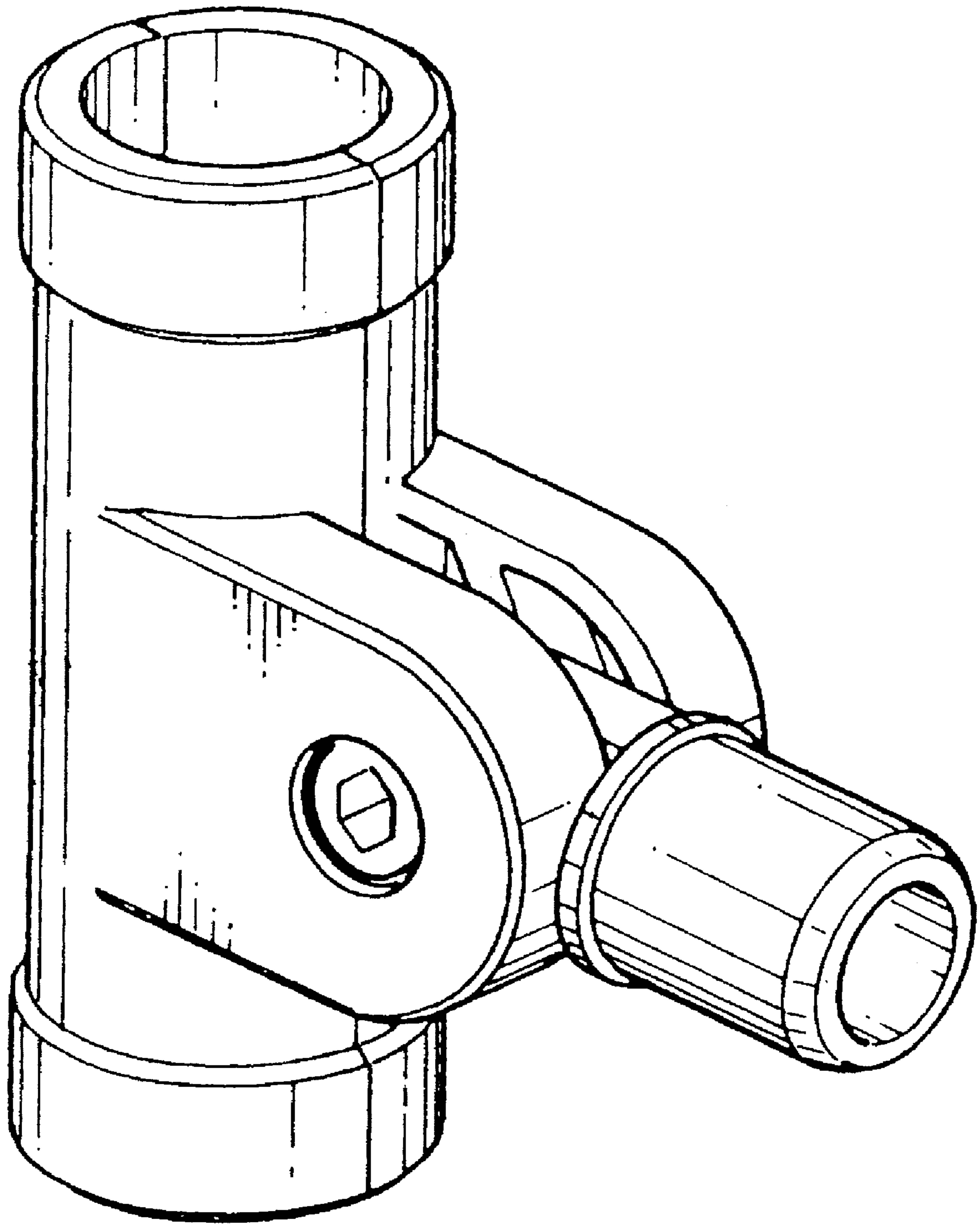

FIG. 2

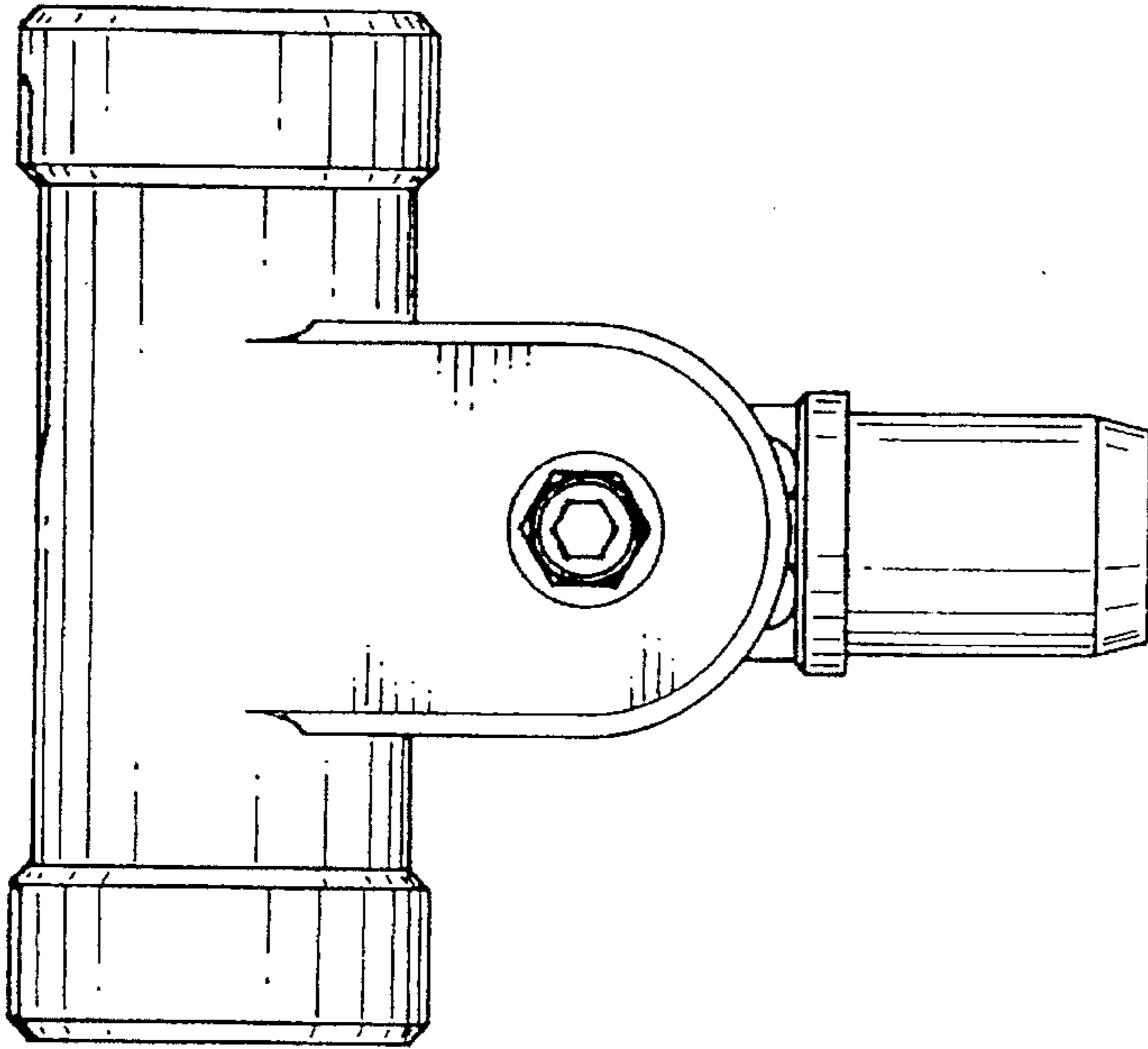

FIG. 5

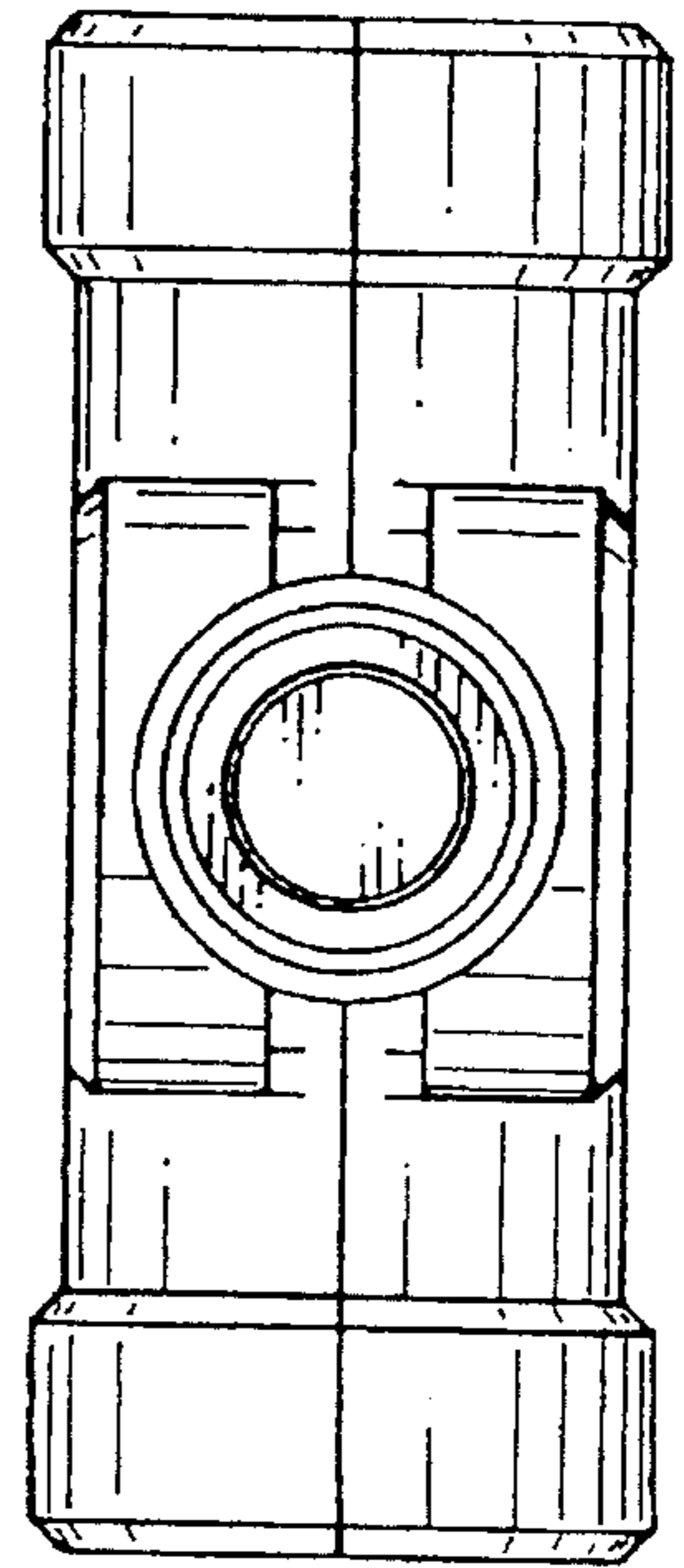

FIG. 3

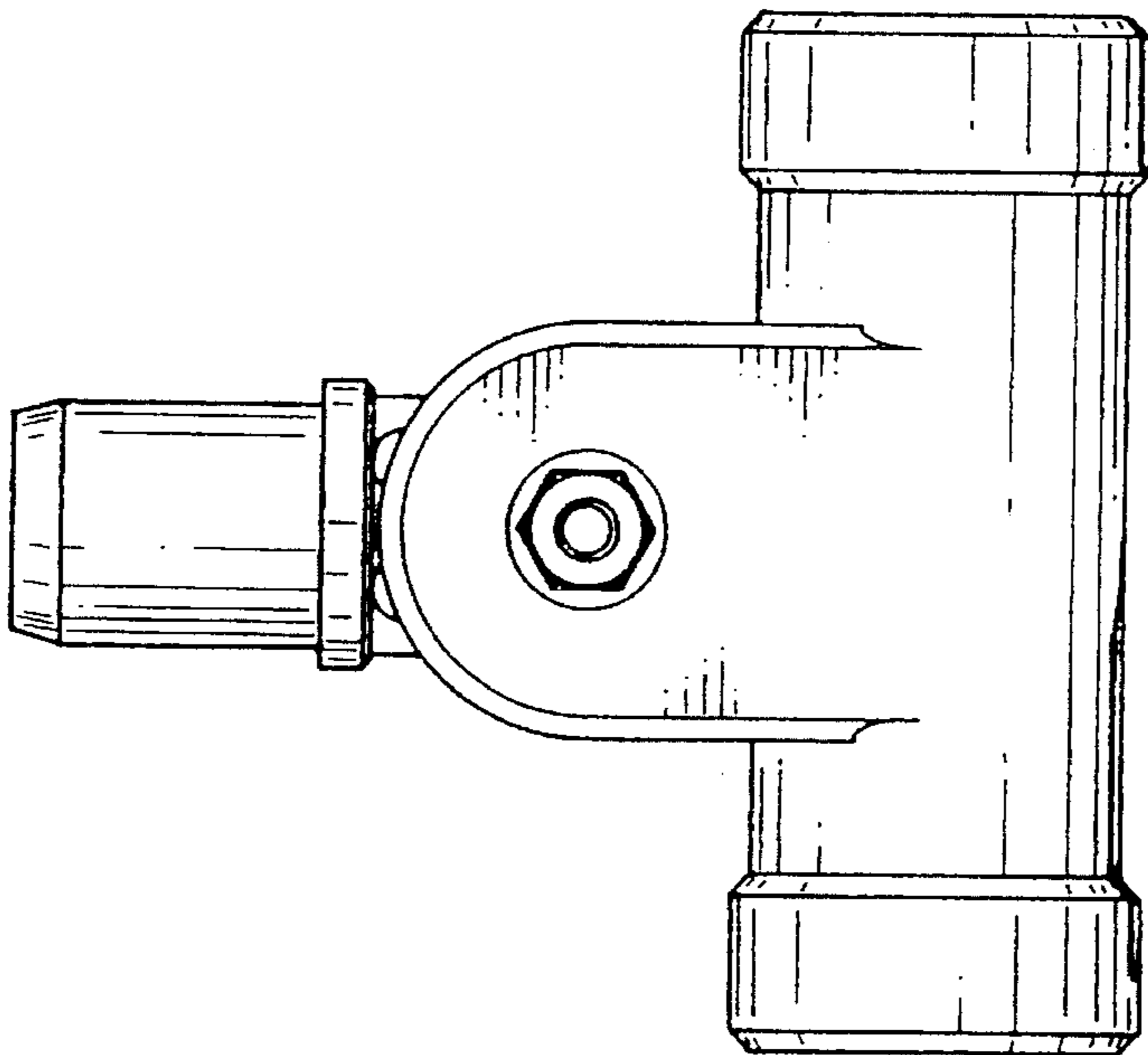

FIG. 6

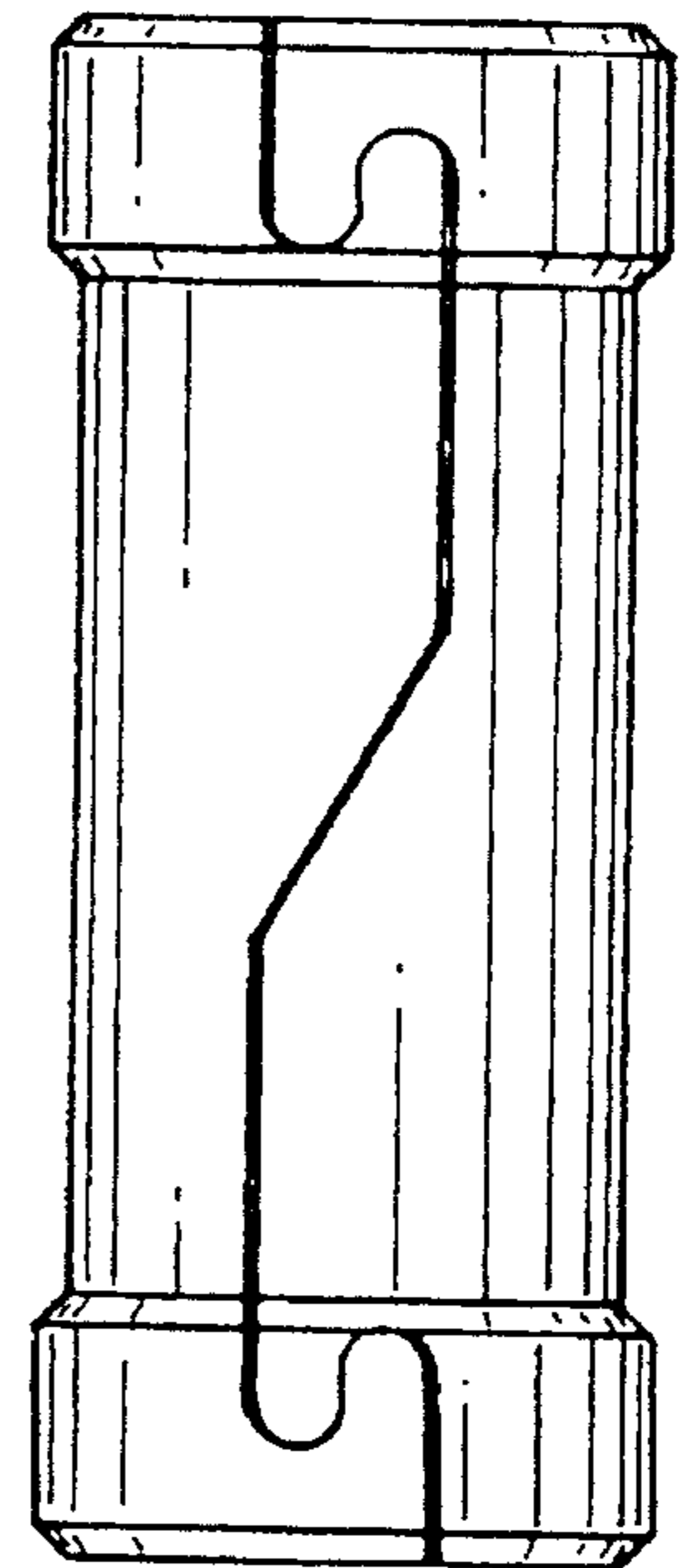

FIG. 4

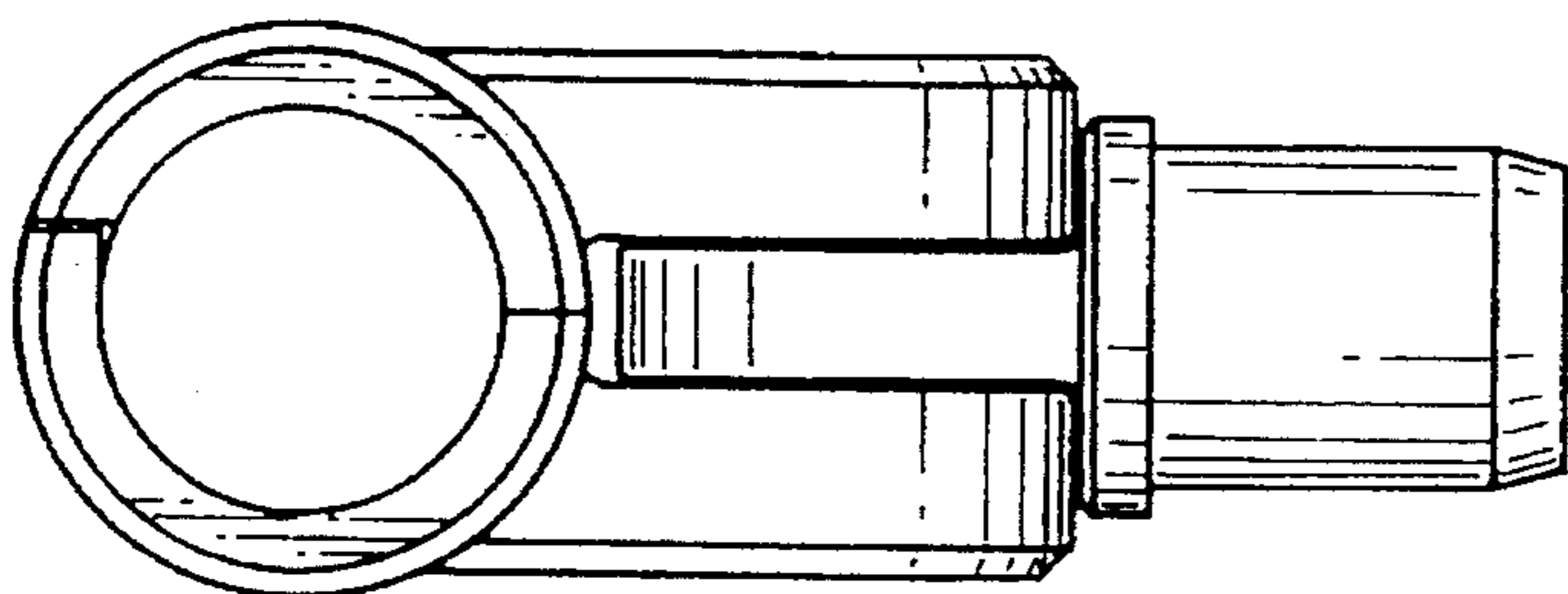

FIG. 7

