



US00D373562S

United States Patent [19]

Cole

[11] Patent Number: Des. 373,562

[45] Date of Patent: **Sep. 10, 1996

[54] WHEEL

[75] Inventor: David Cole, Leiferde, Germany

[73] Assignee: Volkswagen AG, Wolfsburg, Germany

[**] Term: 14 Years

[21] Appl. No.: 43,241

[22] Filed: Aug. 17, 1995

Related U.S. Application Data

[62] Division of Ser. No. 24,282, Jun. 10, 1994, Pat. No. Des. 368,884.

[30] Foreign Application Priority Data

Feb. 1, 1994 [DE] Germany 94 00 882.5

[52] U.S. Cl. D12/211

[58] Field of Search D12/209, 211;
301/64.1, 65

[56] References Cited

PUBLICATIONS

Custom Wheel & Tire Style Guide Supplement To Tire Review, May 1993, p. 39, noble series 40 FWD wheel, center of page.

Custom Wheel & Tire Style Guide Supplement To Tire Review, May 1993, p. 42, 7 Spoke Freedom Design Wheel, bottom left side of page.

Custom Wheel & Tire Style Guide Supplement To Tire Review, May 1993, p. 43, Ronal Wheel, bottom left side of page.

Custom Wheel & Tire Style Guide Supplement To Tire Review, May 1993, p. 45, Primax p. 234 Wheel, second row down from top & second wheel in from left side of page.

Primary Examiner—James M. Gandy
Attorney, Agent, or Firm—Watson Cole Stevens Davis, P.L.L.C.

[57] CLAIM

The ornamental design for a wheel, as shown and described.

DESCRIPTION

FIG. 1 is a perspective view of a new and ornamental design for a wheel in accordance with the present invention;

FIG. 2 is a front elevation of the wheel shown in FIG. 1; and,

FIG. 3 is a side elevation of the wheel illustrated in FIG. 1.

1 Claim, 2 Drawing Sheets

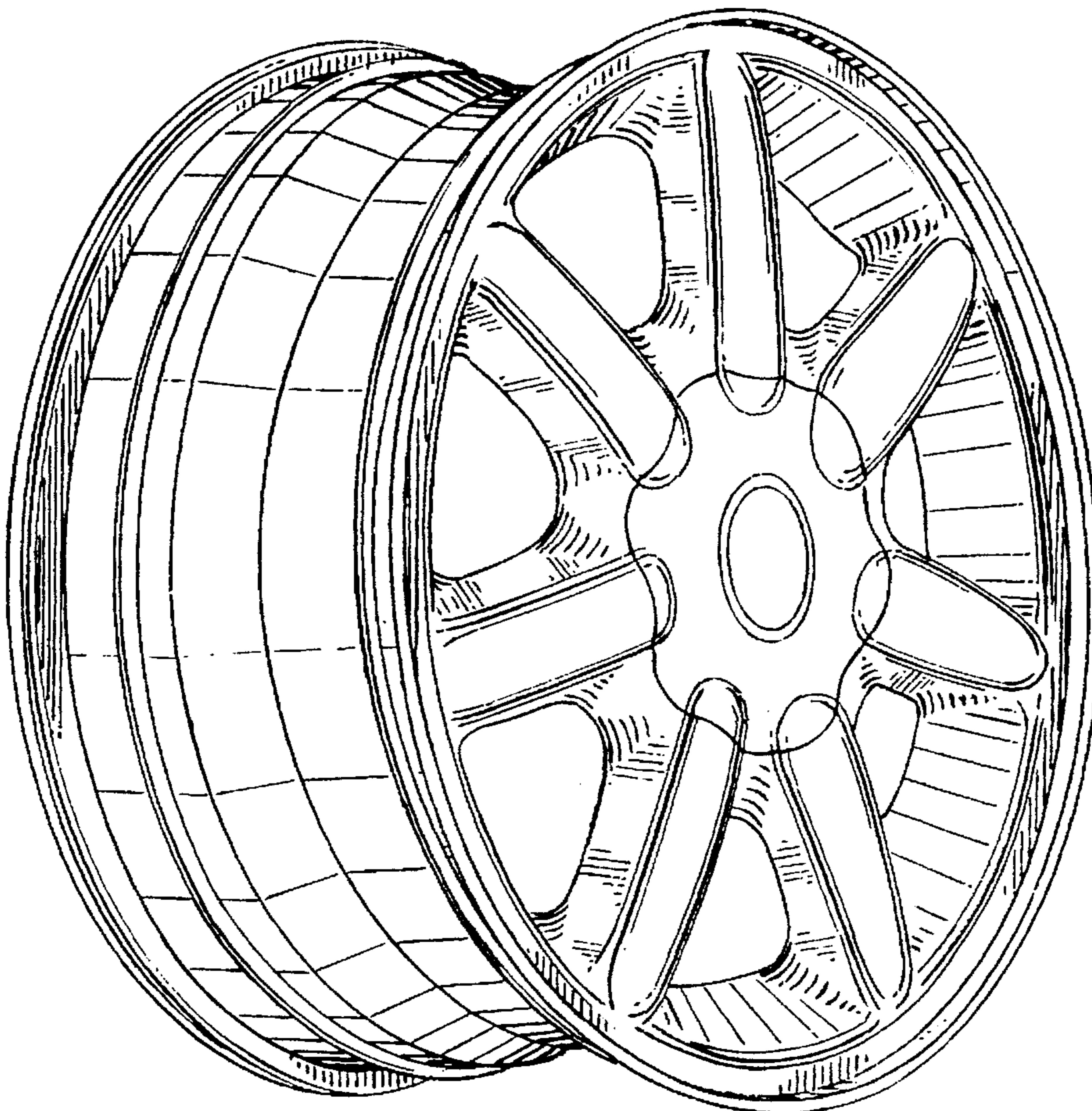

FIG. 1

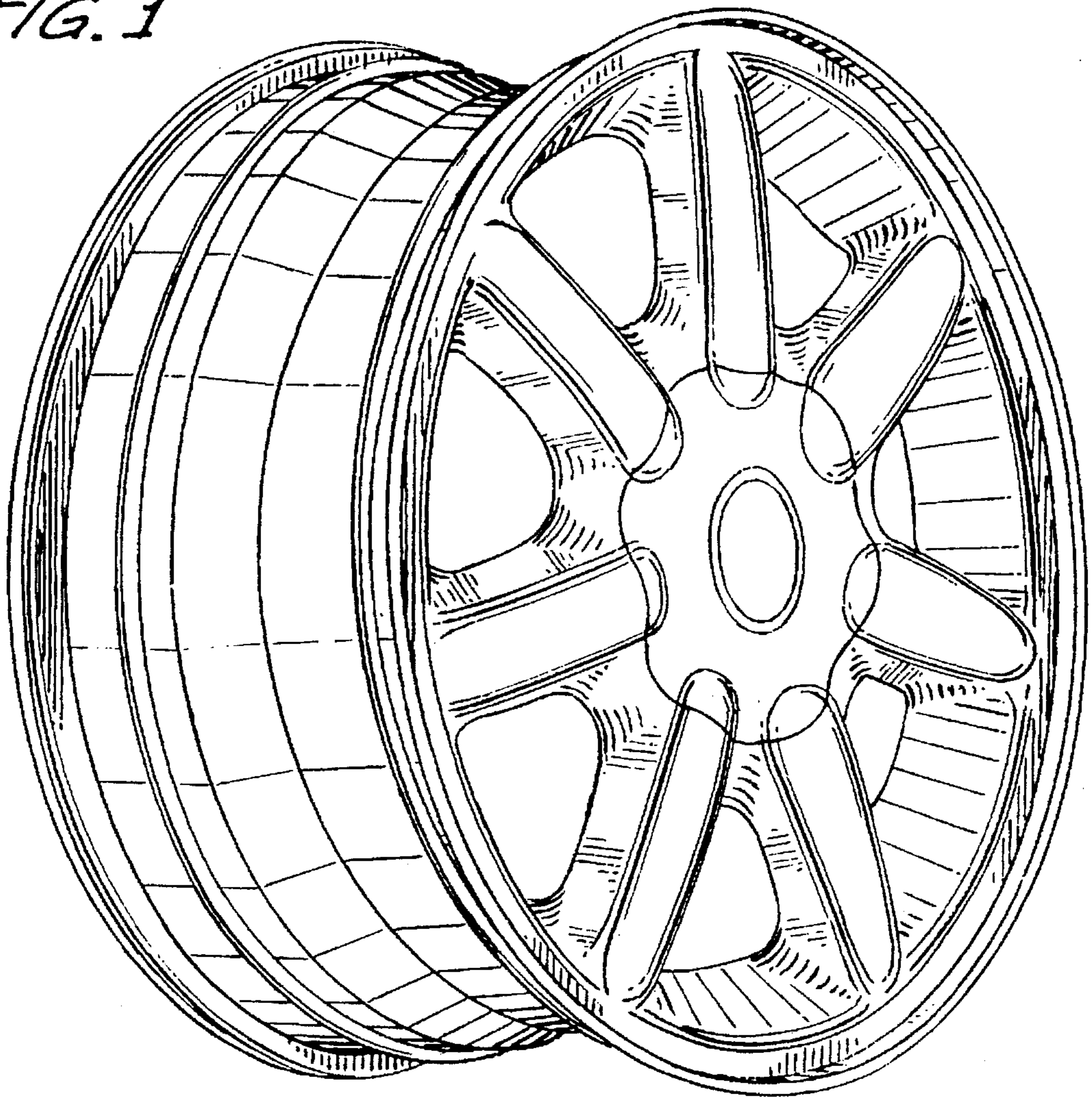

FIG. 2

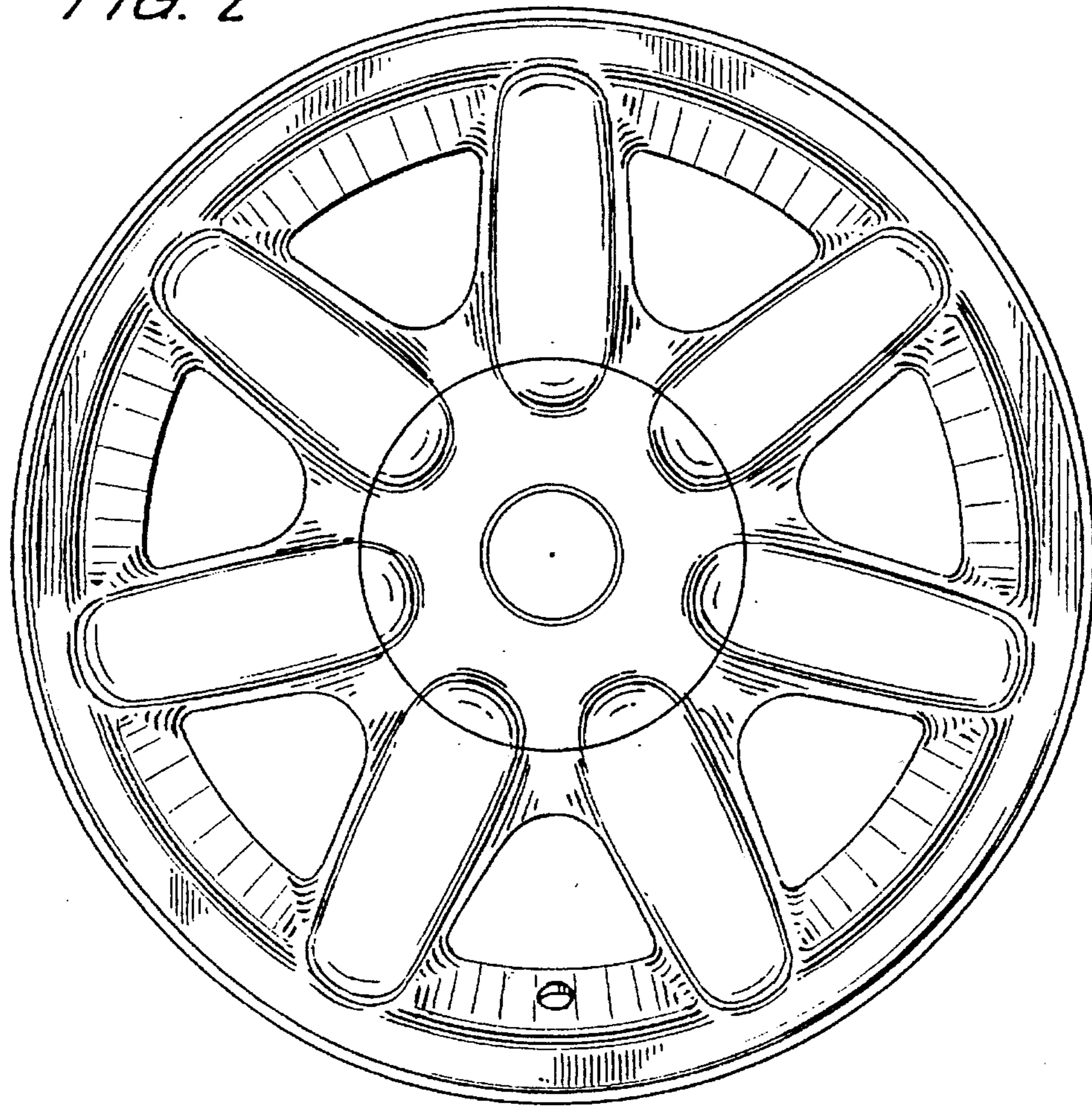

FIG. 3

