



US00D373559S

United States Patent [19]

Shower

[11] Patent Number: **Des. 373,559**

[45] Date of Patent: ****Sep. 10, 1996**

[54] **MOTORCYCLE DASHBOARD PANEL**

[76] Inventor: **Douglas Shower**, 911 Greentree Dr., Winter Park, Fla. 32789

[**] Term: **14 Years**

[21] Appl. No.: **29,219**

[22] Filed: **Sep. 30, 1994**

[52] U.S. Cl. **D12/192; D12/114**

[58] Field of Search **D12/192, 110, D12/114; 280/288.4**

[56] **References Cited**

PUBLICATIONS

- "Harley Davidson Accessories", 1989, 3-Light Dash Cover.
- "Harley Davidson Accessories", 1989, FLH Chrome Instrument Panel.
- "Drag Specialties", 1987, p. 520, Instrument Panel Escutcheon for 80-83 GL.

Primary Examiner—Janice E. Seeger
Assistant Examiner—Cathron B. Matta
Attorney, Agent, or Firm—William M. Hobby, III

[57] **CLAIM**

The ornamental design for a motorcycle dashboard panel, as shown.

DESCRIPTION

- FIG. 1 is a bottom front perspective view of my new motorcycle dashboard panel;
- FIG. 2 is a rear plan view;
- FIG. 3 is a left side elevation;
- FIG. 4 is a sectional view taken on the line 4—4 of FIG. 2;
- FIG. 5 is a bottom elevation; and,
- FIG. 6 is a top elevation.

1 Claim, 1 Drawing Sheet

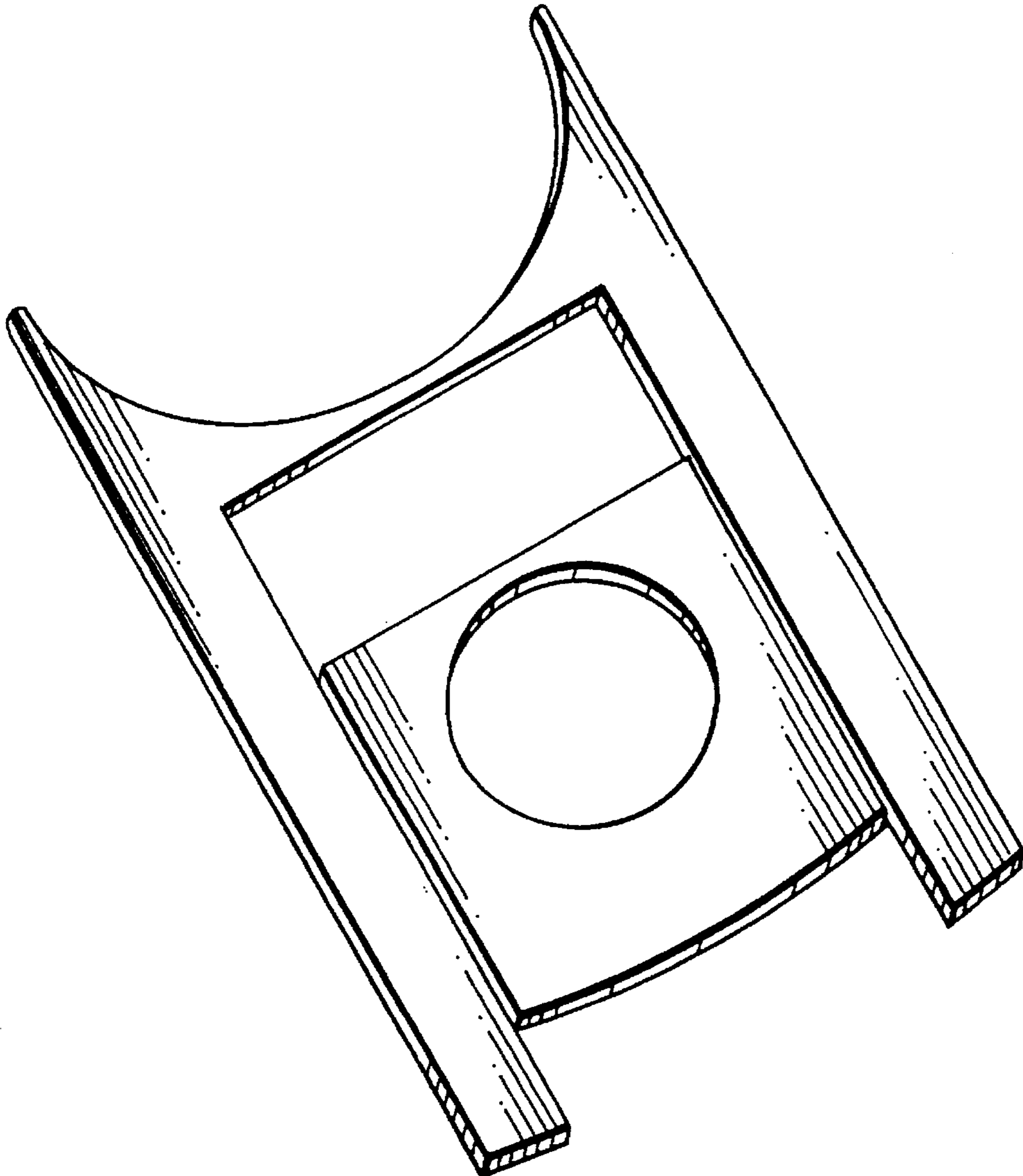

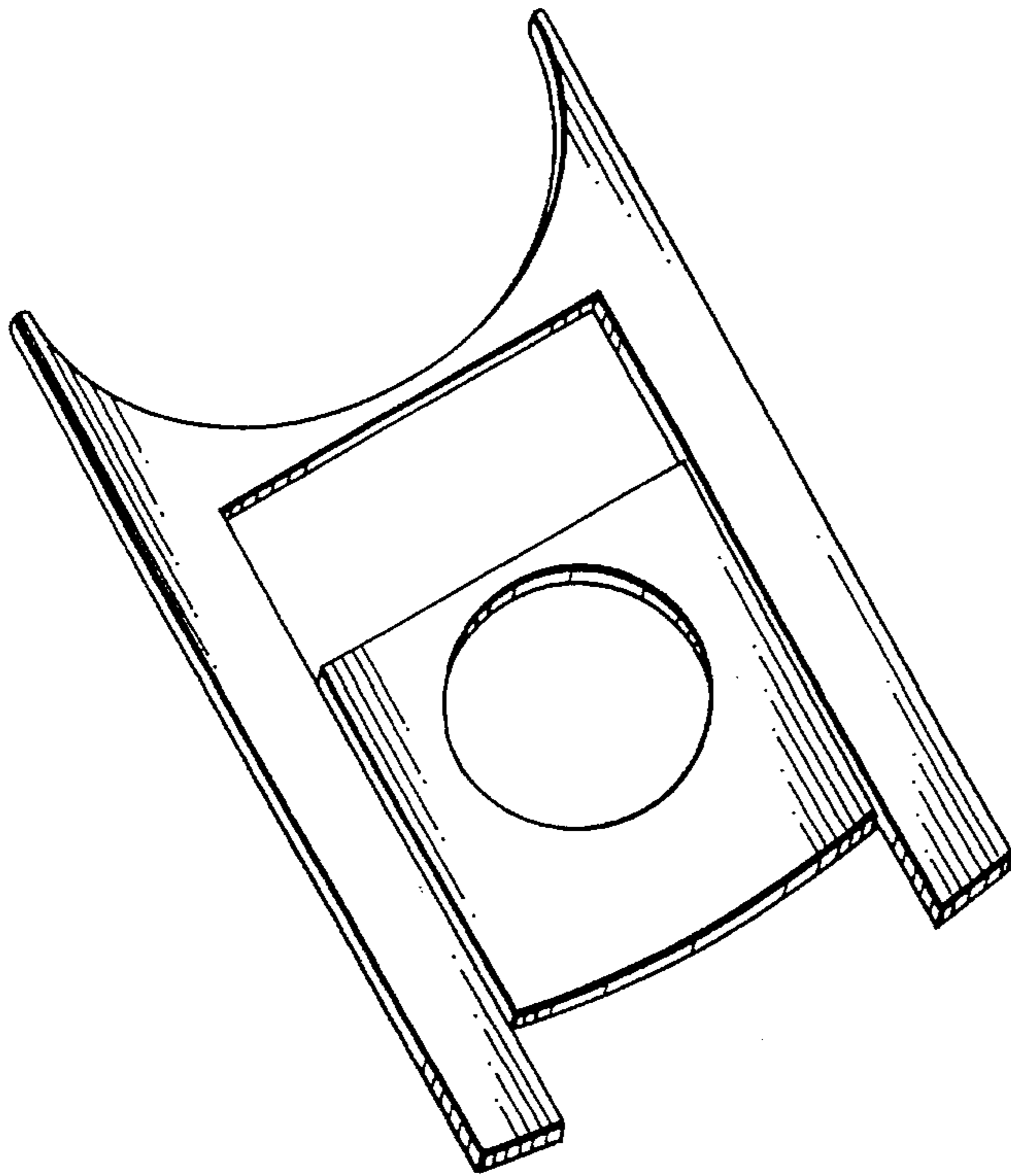

FIG. 1

4 ←

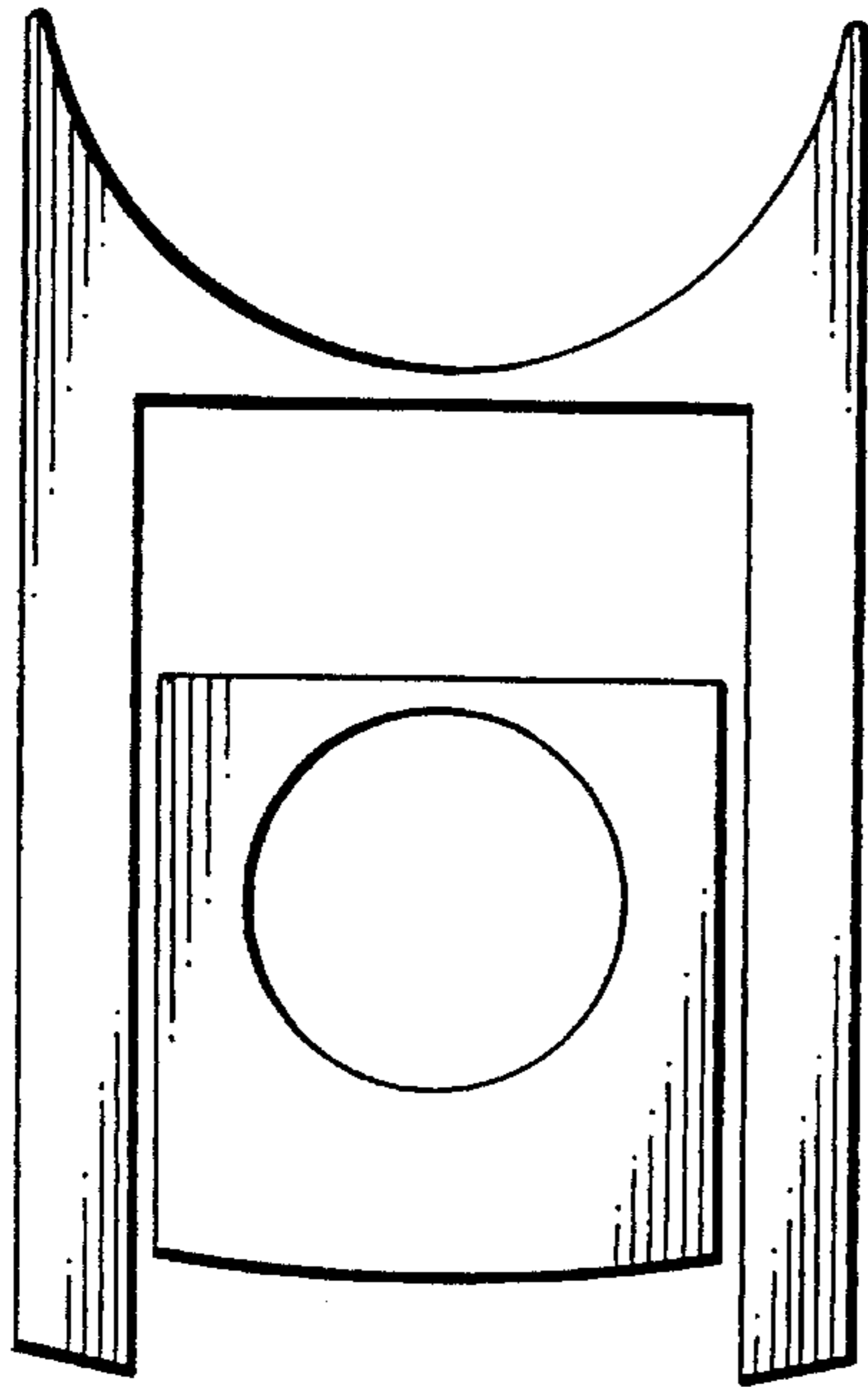

FIG. 2



FIG. 3



FIG. 4



FIG. 5

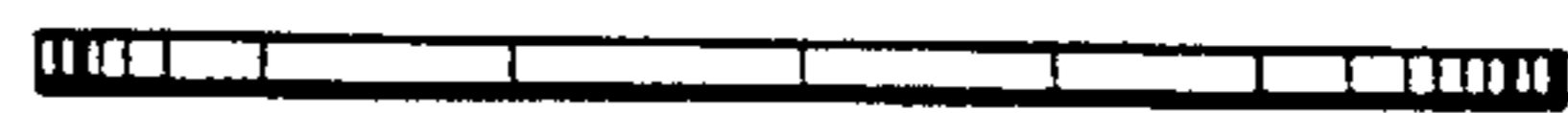

FIG. 6