



US00D373417S

United States Patent [19]
Lee

[11] **Patent Number:** **Des. 373,417**
[45] **Date of Patent:** ****Sep. 3, 1996**

[54] **PORTION OF A CONDENSER TANK USED ON A VEHICLE**

[75] Inventor: **In-Jun Lee**, Taegu, Rep. of Korea

[73] Assignee: **DaeWoo Automotive Component, Ltd.**, Rep. of Korea

[**] Term: **14 Years**

[21] Appl. No.: **26,239**

[22] Filed: **Jul. 22, 1994**

[30] **Foreign Application Priority Data**

Jan. 22, 1994 [KR] Rep. of Korea 94-1407

[52] **U.S. Cl.** **D23/386**

[58] **Field of Search** D23/324-325,
D23/328, 386; 123/41.21, 41.29, 41.54;
62/507; 165/110, 135, 140, 173, 176

[56] **References Cited**

U.S. PATENT DOCUMENTS

3,411,316	11/1968	Wright	62/507	X
3,424,236	1/1969	Hergott	62/507	X
5,186,243	2/1993	Halstead	165/135	
5,193,613	3/1993	Wallis	165/173	

Primary Examiner—A. Hugo Word
Assistant Examiner—Lavone D. Tabor
Attorney, Agent, or Firm—Laff, Whitesel, Conte & Saret, Ltd.

[57] **CLAIM**

The ornamental design for a portion of a condenser tank used on a vehicle, as shown and described.

DESCRIPTION

FIG. 1 is a perspective view of a portion of a condenser tank used on a vehicle showing my new design;
FIG. 2 is a front view thereof;
FIG. 3 is a rear view thereof;
FIG. 4 is a top plan view thereof;
FIG. 5 is a bottom plan view thereof;
FIG. 6 is a cross-sectional view taken along line 6—6 of FIG. 4;
FIG. 7 is a cross-sectional view taken along line 7—7 of FIG. 4;
FIG. 8 is a cross-sectional view taken along line 8—8 of FIG. 4; and,
FIG. 9 is an end view thereof, the opposite end being a mirror image.

1 Claim, 3 Drawing Sheets

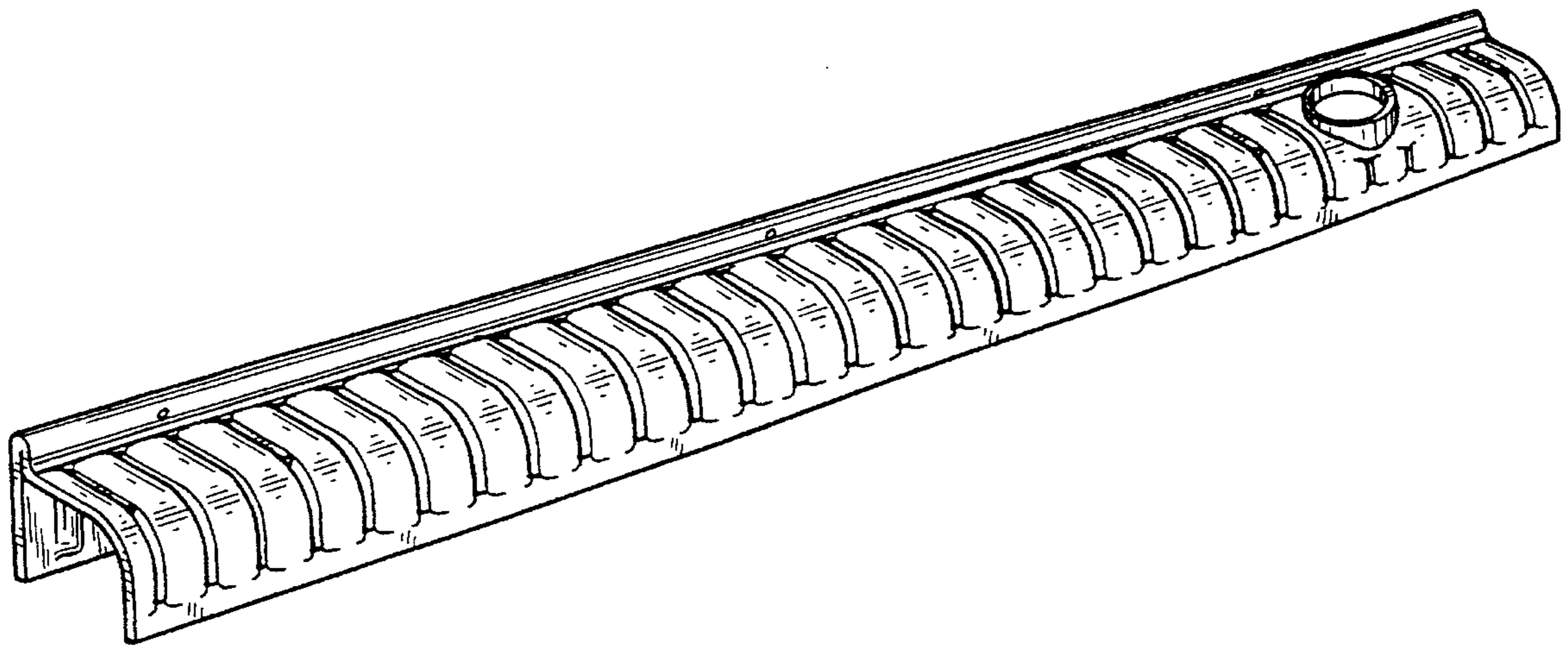

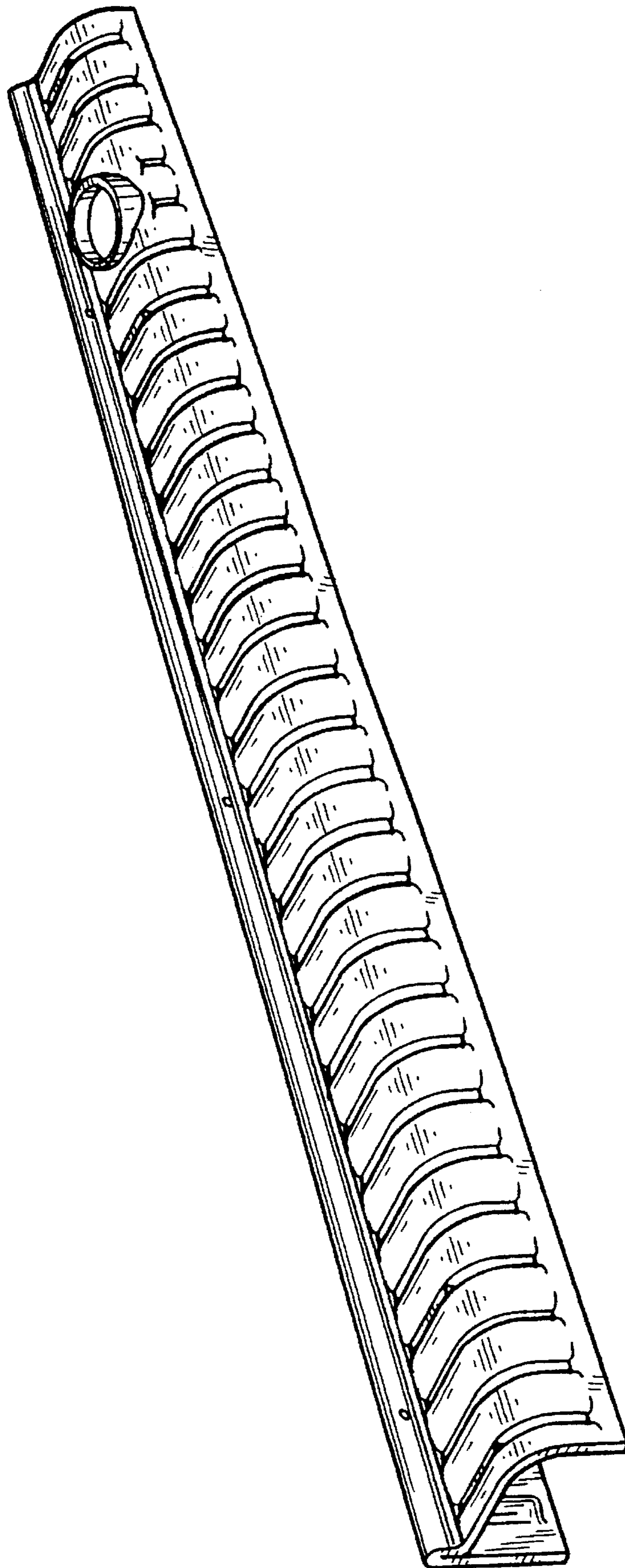

FIG. 1

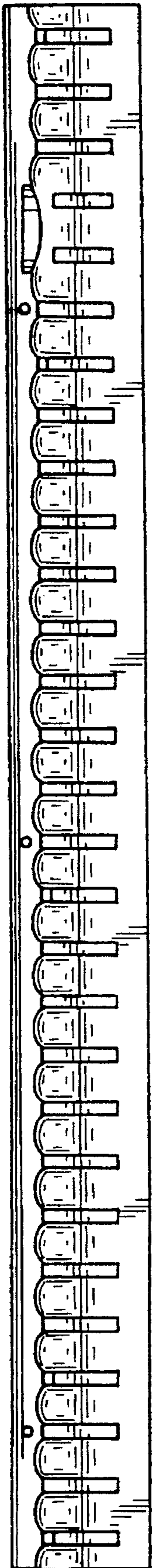

FIG. 2

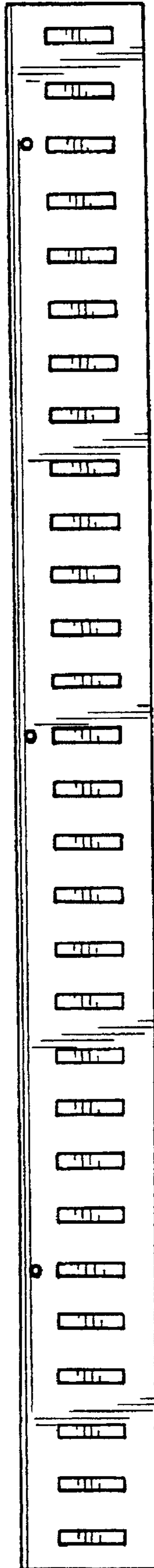

FIG. 3

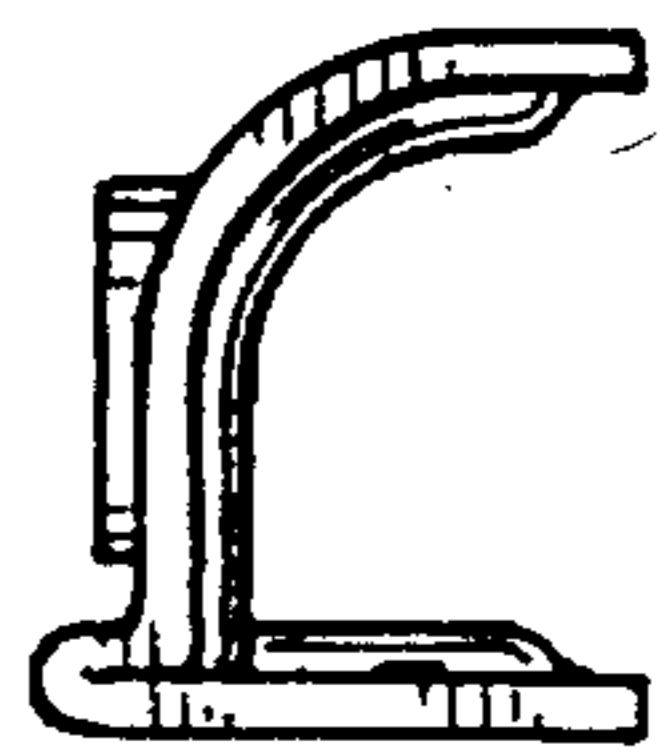

FIG. 9

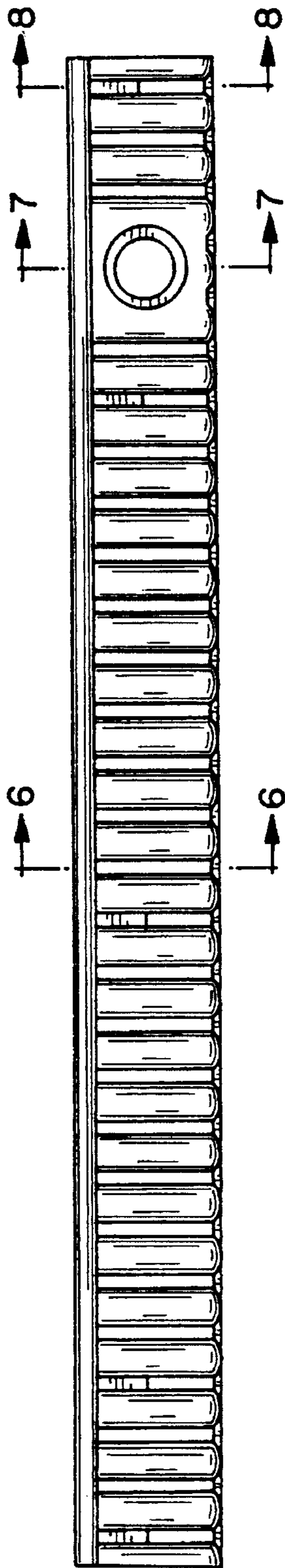

FIG. 4

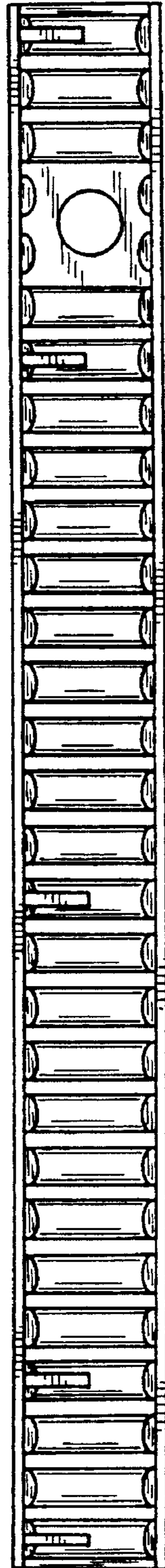

FIG. 5

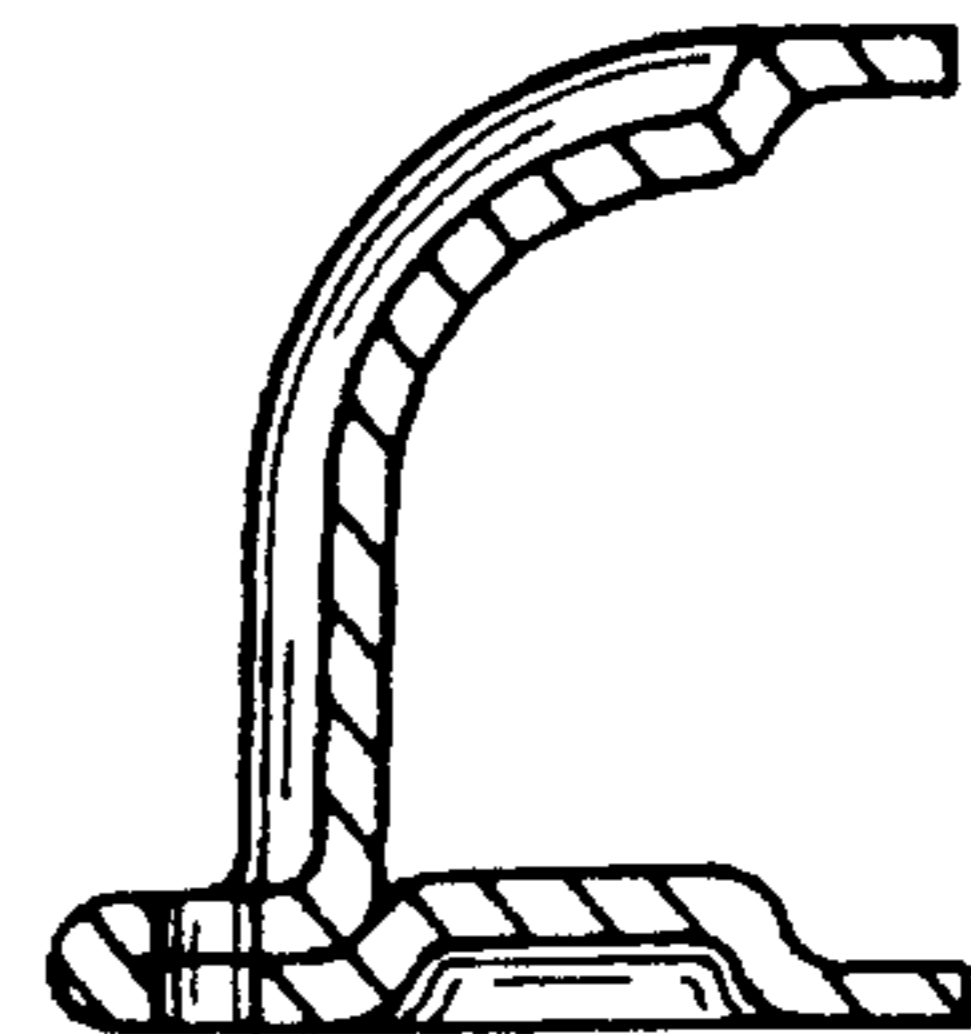

FIG. 6

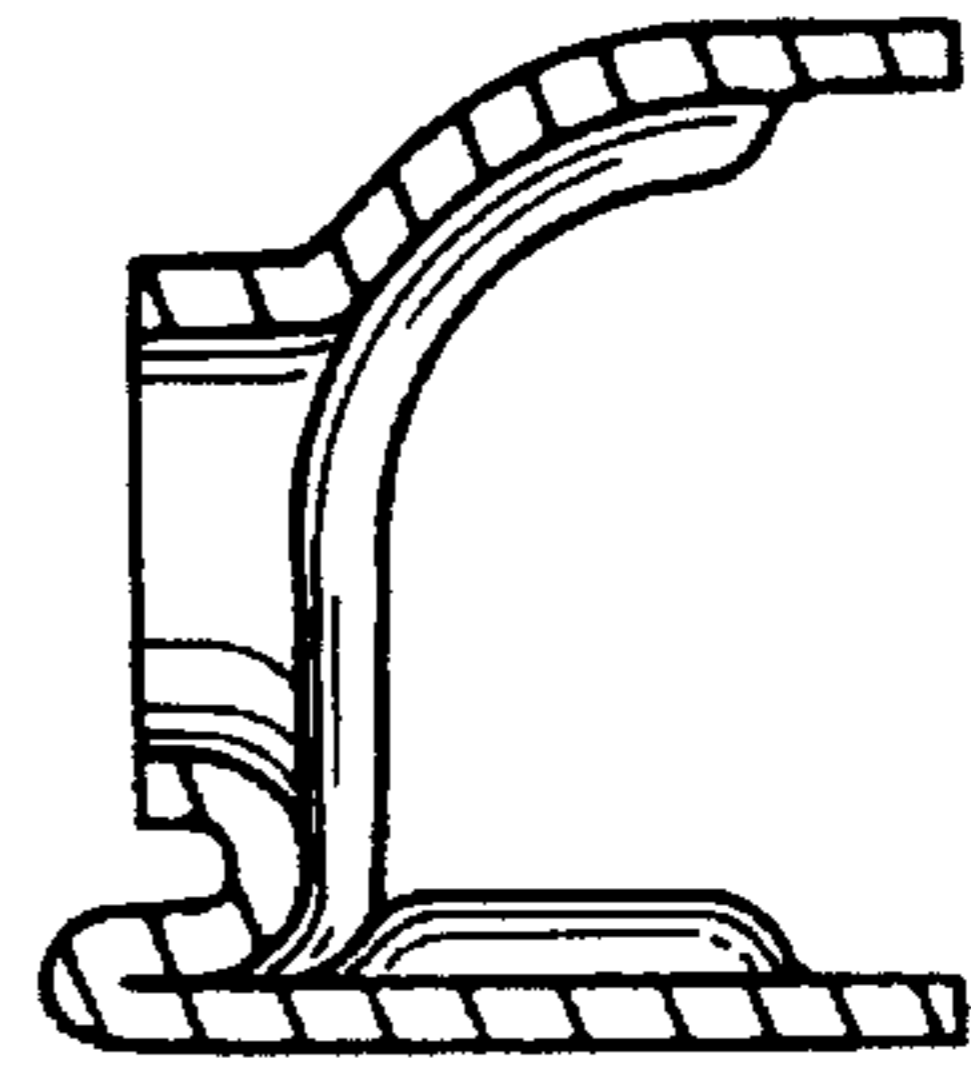

FIG. 7

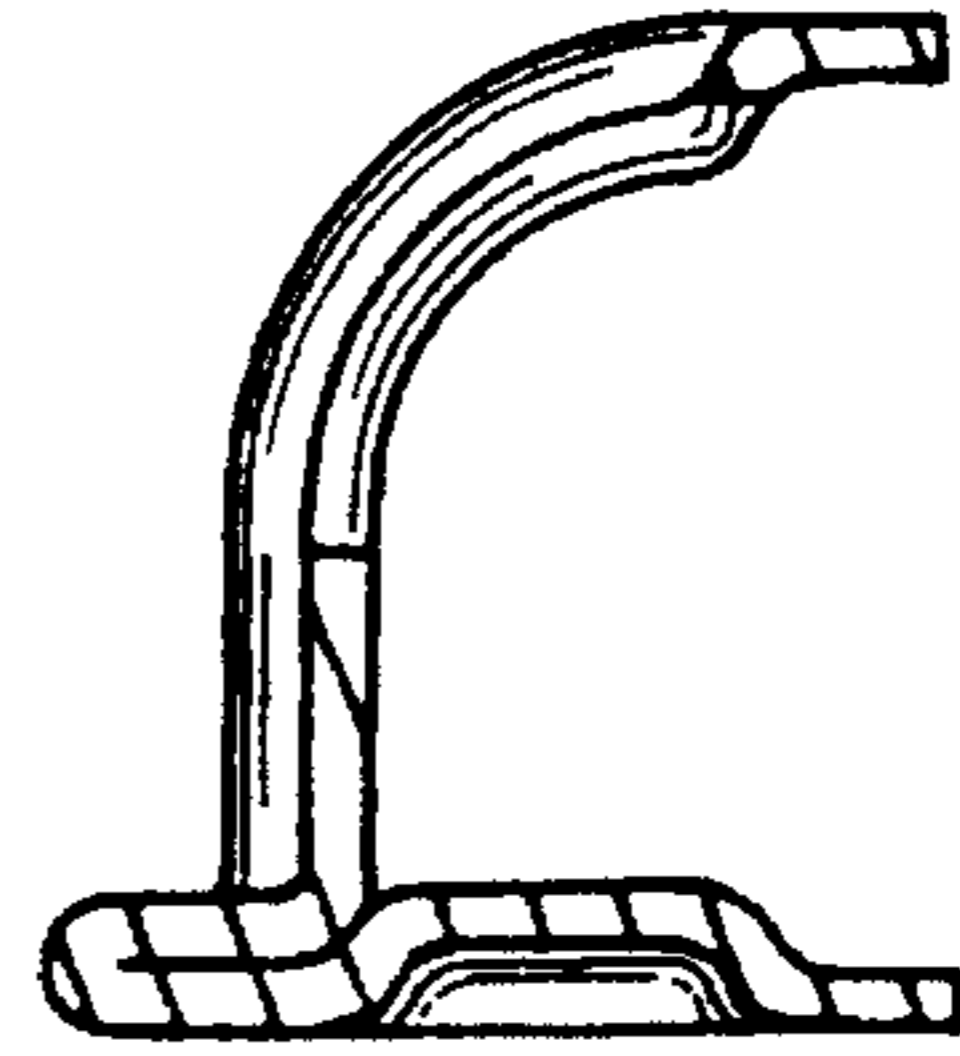

FIG. 8