



US00D373335S

# United States Patent [19]

Repke

[11] Patent Number: **Des. 373,335**

[45] Date of Patent: **\*\*Sep. 3, 1996**

[54] **FLAT BED TRAILER**

[76] Inventor: **Neil D. Repke**, P.O. Box 326, Palmer, Mich. 49871

[\*\*] Term: **14 Years**

[21] Appl. No.: **42,112**

[22] Filed: **Aug. 1, 1995**

### Related U.S. Application Data

[63] Continuation-in-part of Ser. No. 11,722, Aug. 13, 1993, Pat. No. Des. 361,047.

[52] **U.S. Cl.** ..... **D12/101**

[58] **Field of Search** ..... D12/101, 105; 280/63, 656; 296/181, 184

### [56] References Cited

#### U.S. PATENT DOCUMENTS

|            |         |         |       |         |
|------------|---------|---------|-------|---------|
| D. 230,725 | 3/1974  | Lundell | ..... | D12/101 |
| D. 268,257 | 3/1983  | Horton  | ..... | D12/105 |
| D. 274,507 | 7/1986  | Wilson  | ..... | D12/105 |
| D. 277,271 | 1/1985  | Law     | ..... | D12/101 |
| D. 286,992 | 12/1986 | Doering | ..... | D12/105 |

|            |        |           |       |         |
|------------|--------|-----------|-------|---------|
| D. 325,549 | 4/1992 | Jarvis    | ..... | D12/105 |
| D. 361,047 | 8/1995 | Repke     | ..... | D12/101 |
| 3,578,806  | 5/1971 | Tonelli   | ..... | D12/105 |
| 4,772,038  | 9/1988 | MacDonald | ..... | 280/656 |

*Primary Examiner*—Melody N. Brown  
*Attorney, Agent, or Firm*—Marshall & Melhorn

### [57] CLAIM

The ornamental design for a flat bed trailer, as shown and described.

### DESCRIPTION

FIG. 1 is a front perspective view of a flat bed trailer showing my new design; FIG. 2 is a rear perspective view thereof; FIG. 3 is a front elevational view thereof; FIG. 4 is a rear elevational view thereof; FIG. 5 is a side elevational view thereof; FIG. 6 is a top plan view thereof; and, FIG. 7 is a bottom plan view thereof.

The broken lines shown in FIGS. 3 and 5 are for illustrative purposes only and form no part of the claimed design.

**1 Claim, 2 Drawing Sheets**

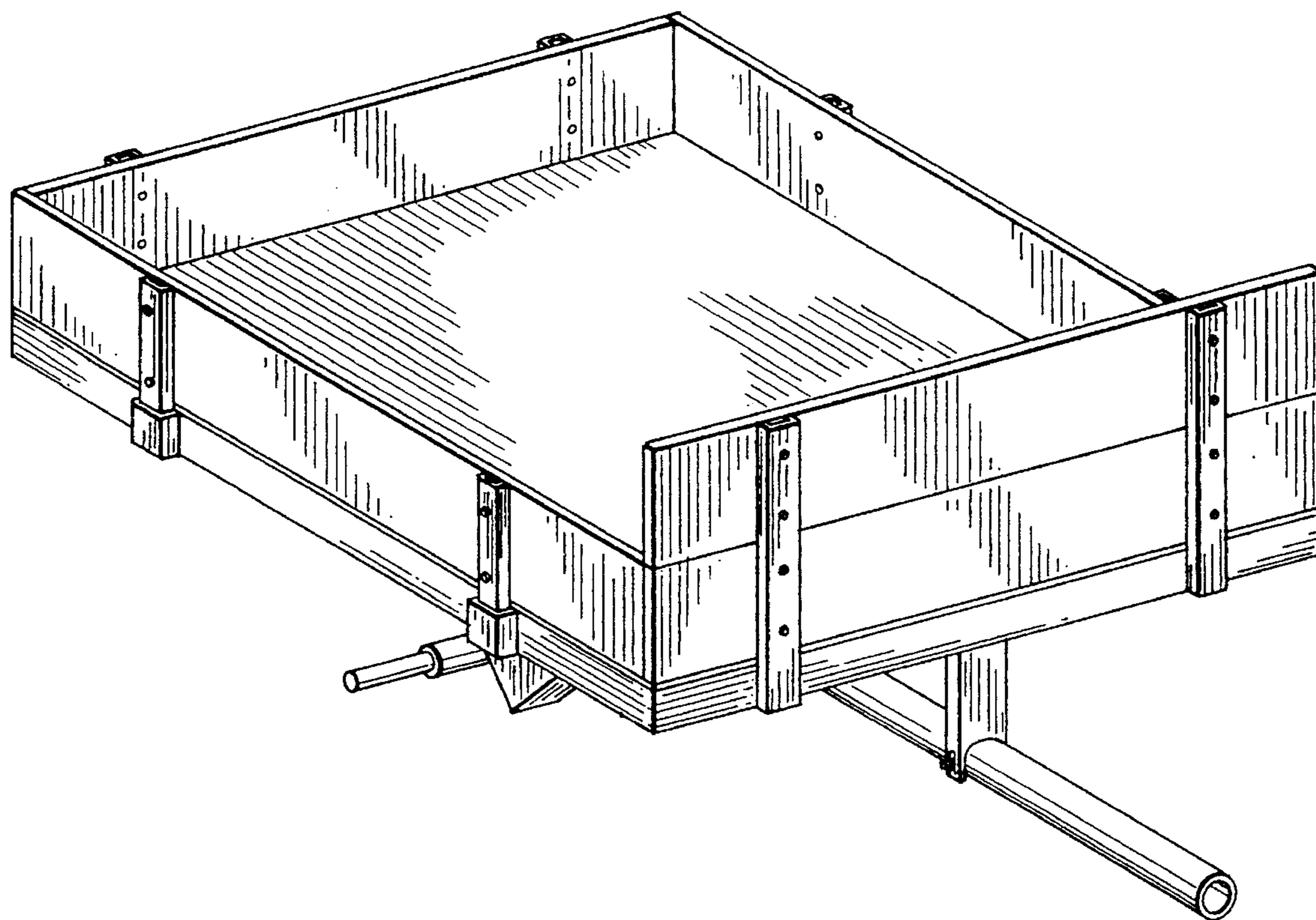

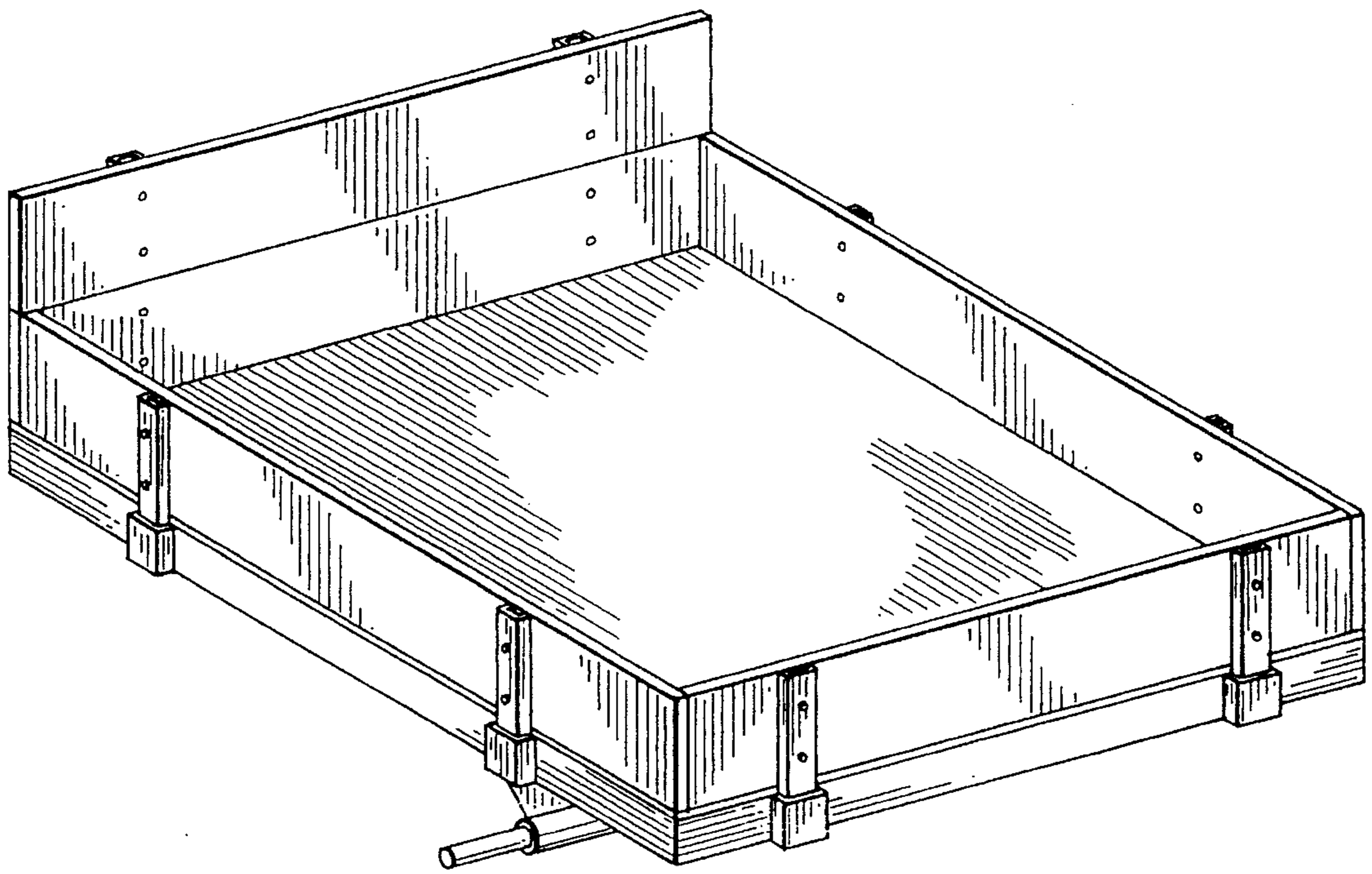
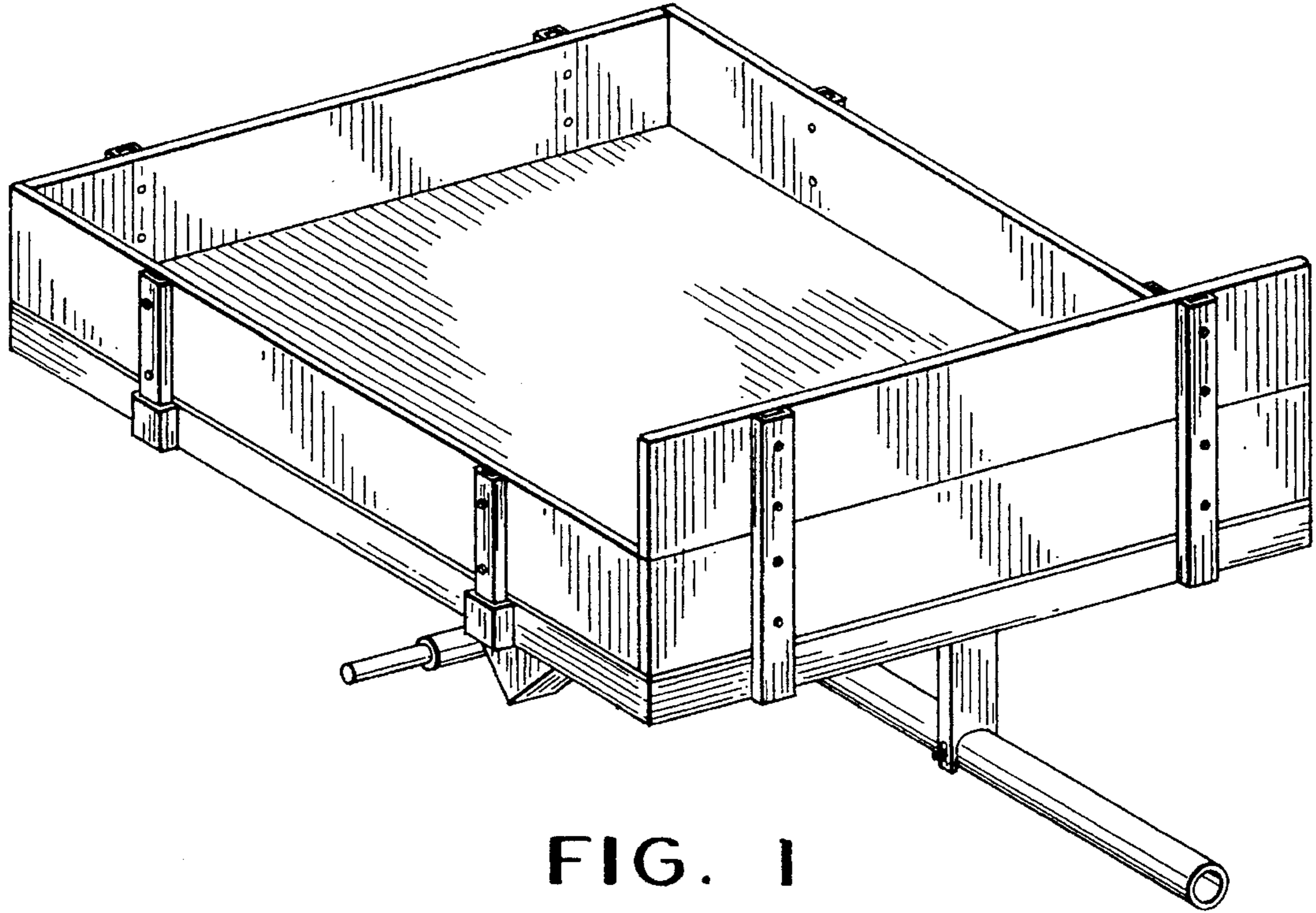

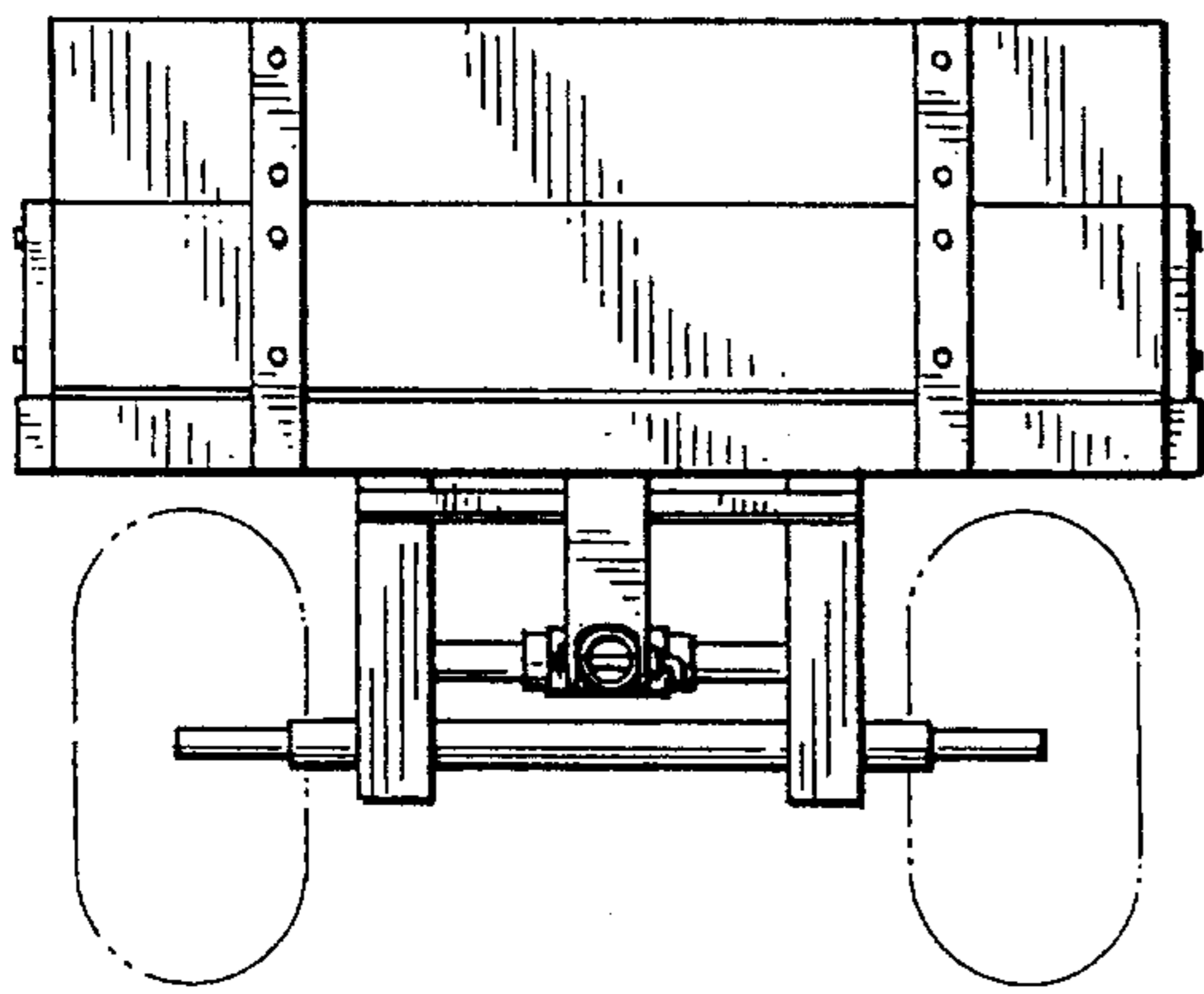

FIG. 3

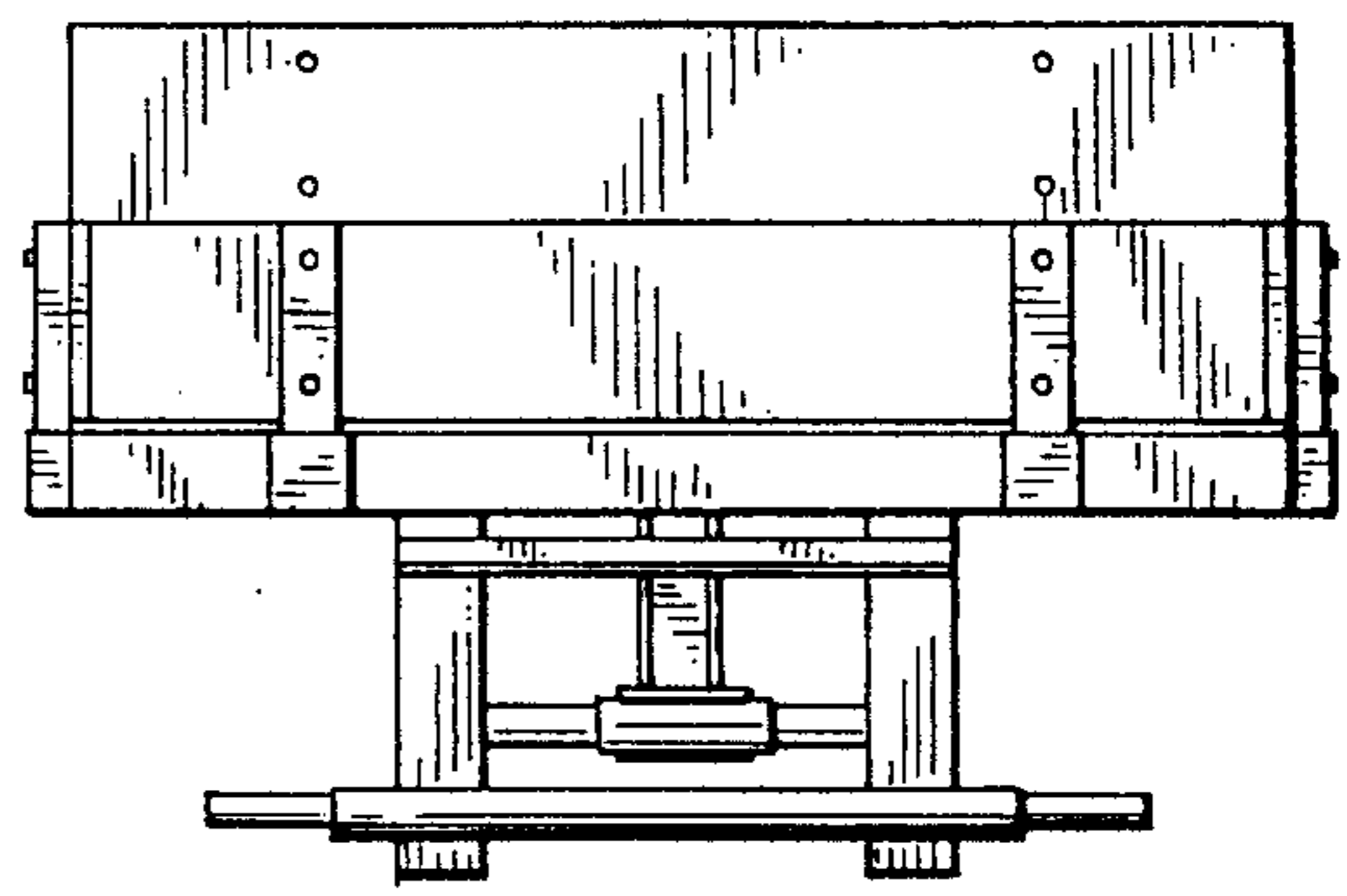

FIG. 4

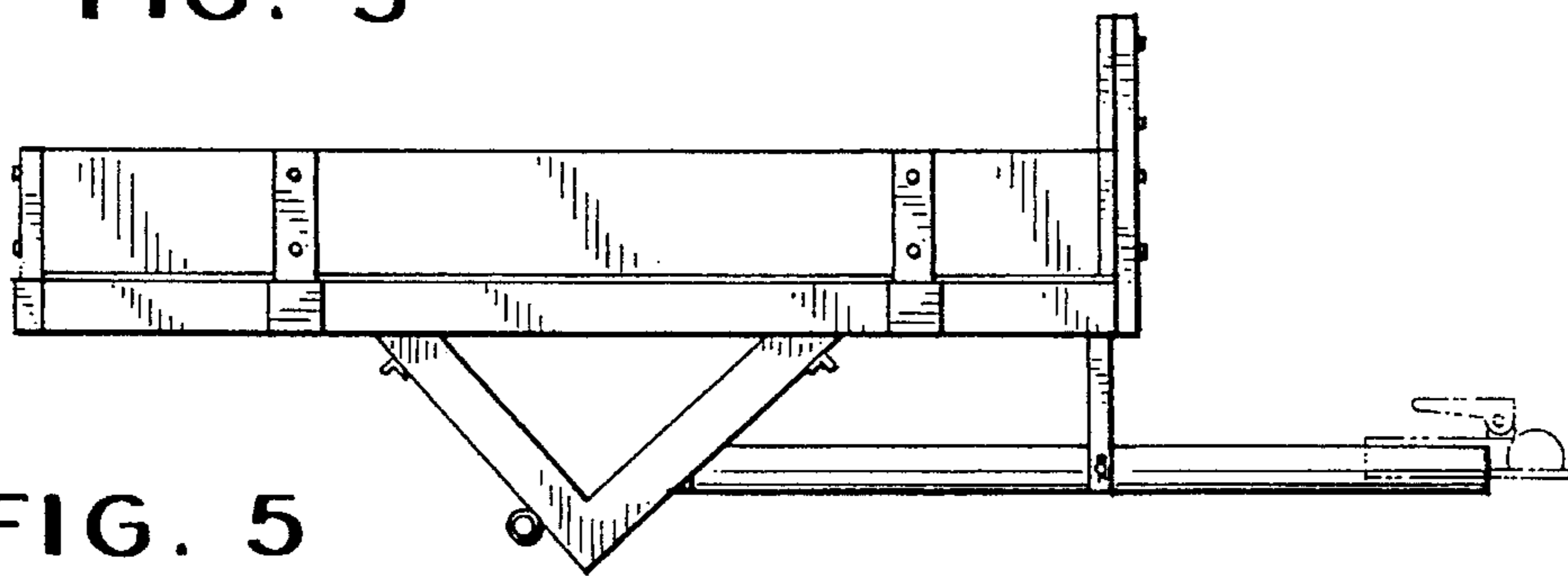

FIG. 5

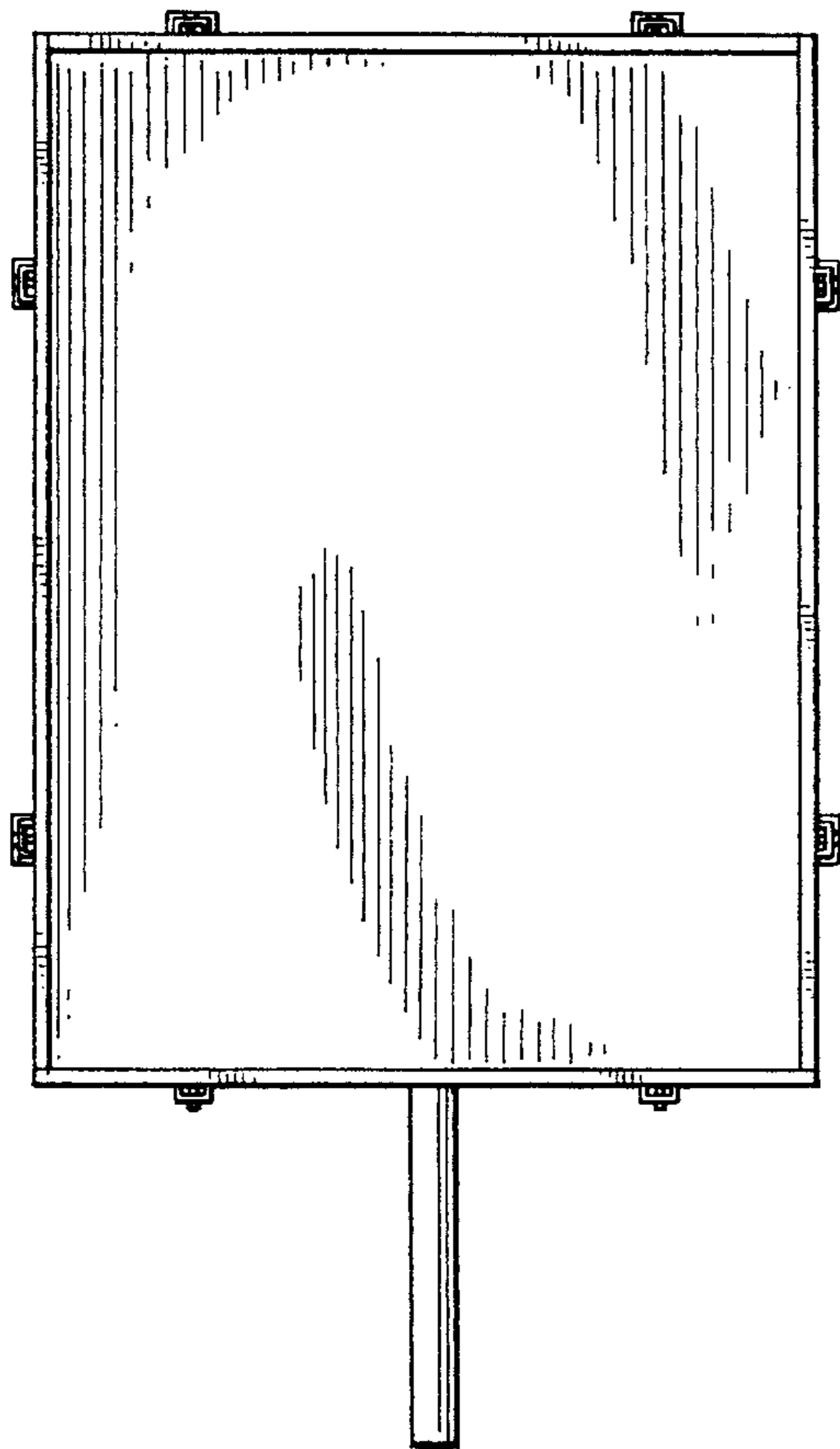

FIG. 6

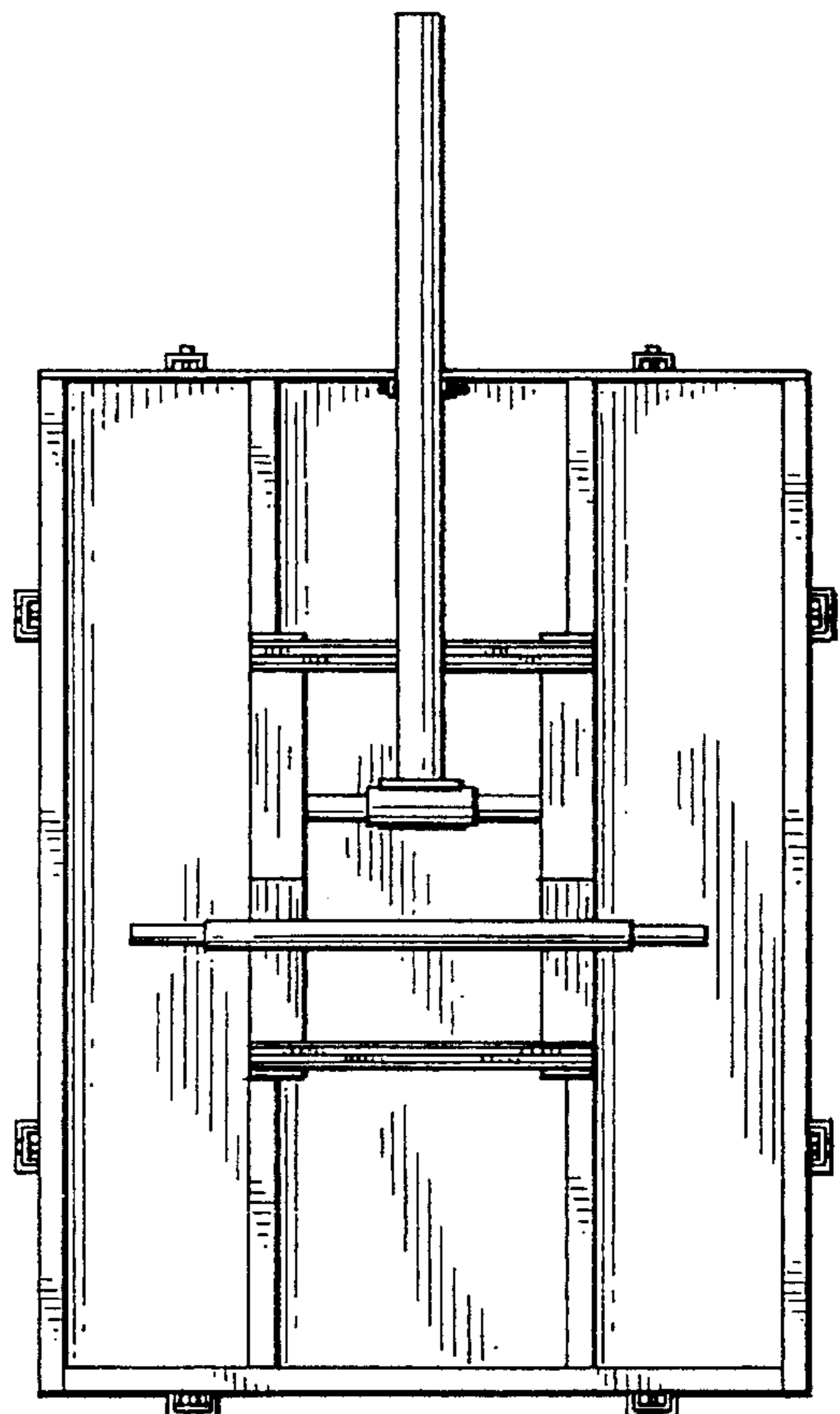

FIG. 7