



US00D373334S

# United States Patent [19]

[11] Patent Number: **Des. 373,334**

Honda et al.

[45] Date of Patent: **\*\*Sep. 3, 1996**

[54] **AUTOMOBILE**

D. 347,201 5/1994 Kaku et al. .... D12/92

[75] Inventors: **Mitsubishi Honda; Tamotsu Okamoto**,  
both of Saitama, Japan

### OTHER PUBLICATIONS

Motor Trend, Mar. 1994, p. 14, Toyota Avalon.  
Motor Trend, Sep. 1994, p. 46, Lexus LS 400, bottom of  
page.

[73] Assignee: **Honda Giken Kogyo Kabushiki  
Kaisha**, Tokyo, Japan

*Primary Examiner*—James M. Gandy  
*Attorney, Agent, or Firm*—Birch, Stewart, Kolasch & Birch,  
LLP

[\*\*] Term: **14 Years**

[21] Appl. No.: **38,492**

### [57] CLAIM

[22] Filed: **May 4, 1995**

The ornamental design for an automobile, as shown and  
described.

### [30] Foreign Application Priority Data

### DESCRIPTION

Nov. 4, 1994 [JP] Japan ..... 6-33758

[52] U.S. Cl. .... **D12/92**

[58] Field of Search ..... D12/91, 92; 296/185

FIG. 1 is a front perspective view of an automobile showing  
our new design;

FIG. 2 is a right side elevational view thereof;

FIG. 3 is a left side elevational view thereof;

FIG. 4 is a top plan view thereof;

FIG. 5 is a front elevational view thereof;

FIG. 6 is a rear elevational view thereof; and,

FIG. 7 is a rear perspective view thereof.

### [56] References Cited

#### U.S. PATENT DOCUMENTS

|            |        |                       |        |
|------------|--------|-----------------------|--------|
| D. 317,887 | 7/1991 | Shimoyama et al. .... | D12/92 |
| D. 318,636 | 7/1991 | Shimoyama et al. .... | D12/92 |
| D. 323,635 | 2/1992 | Koike et al. ....     | D12/92 |
| D. 323,799 | 2/1992 | Nishimura et al. .... | D12/92 |
| D. 327,239 | 6/1992 | Ui et al. ....        | D12/92 |

**1 Claim, 6 Drawing Sheets**

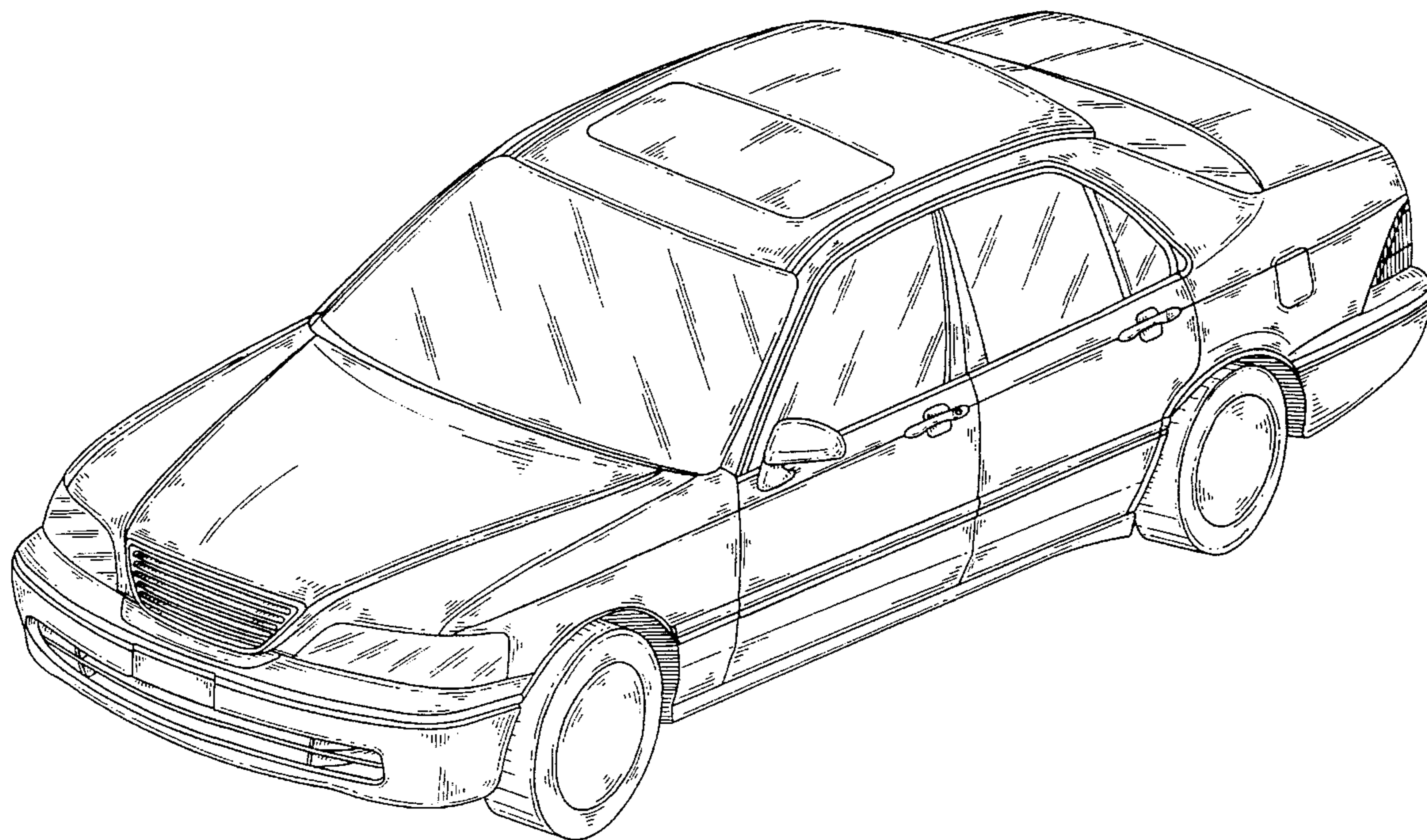

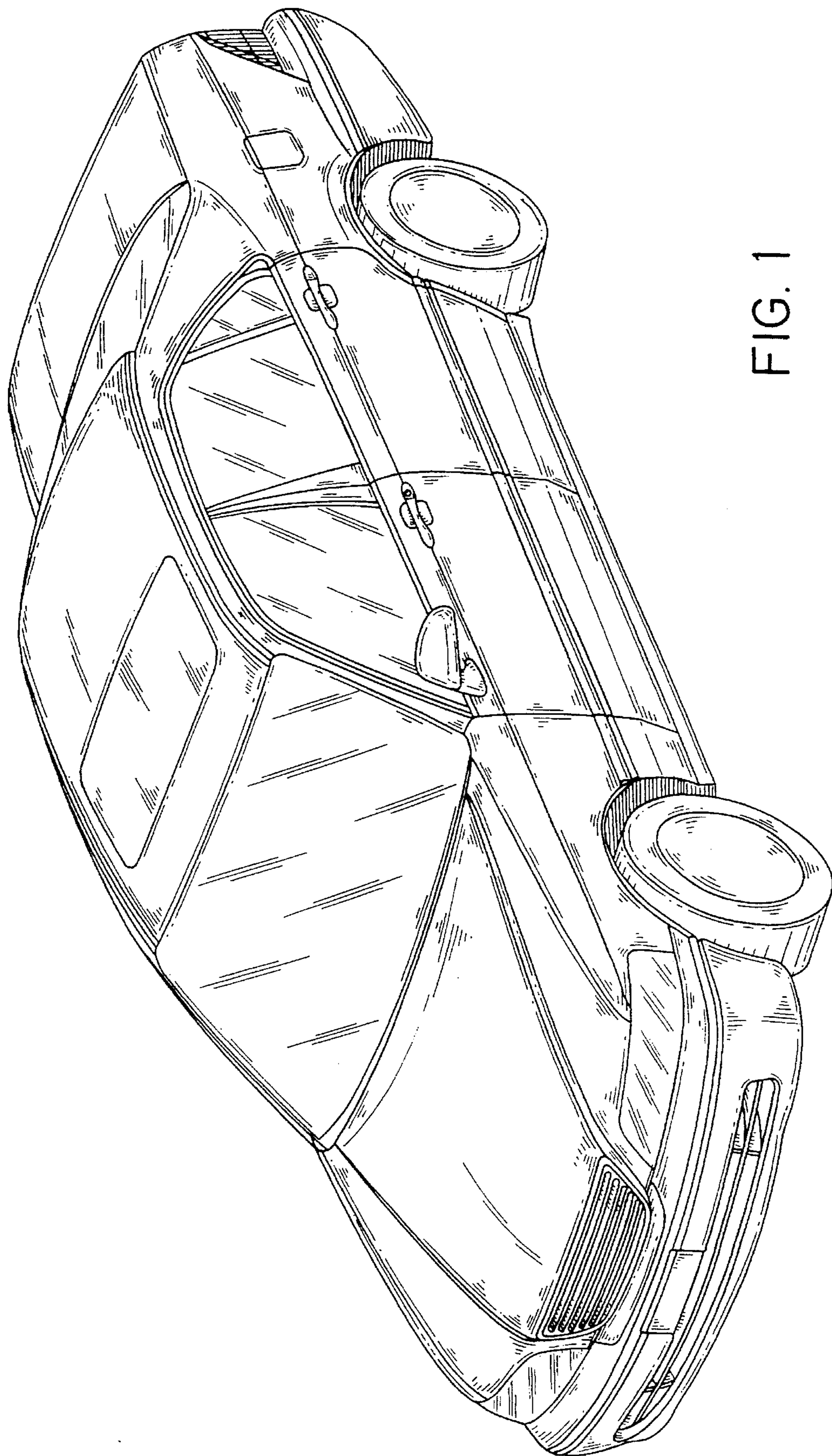

FIG. 1

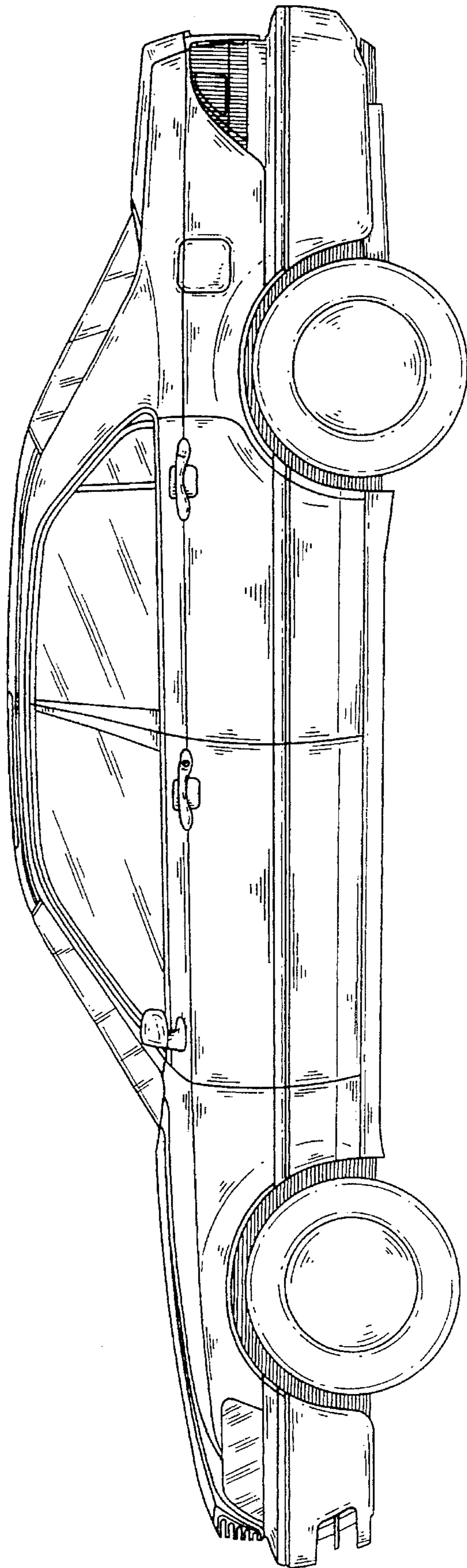

FIG. 2

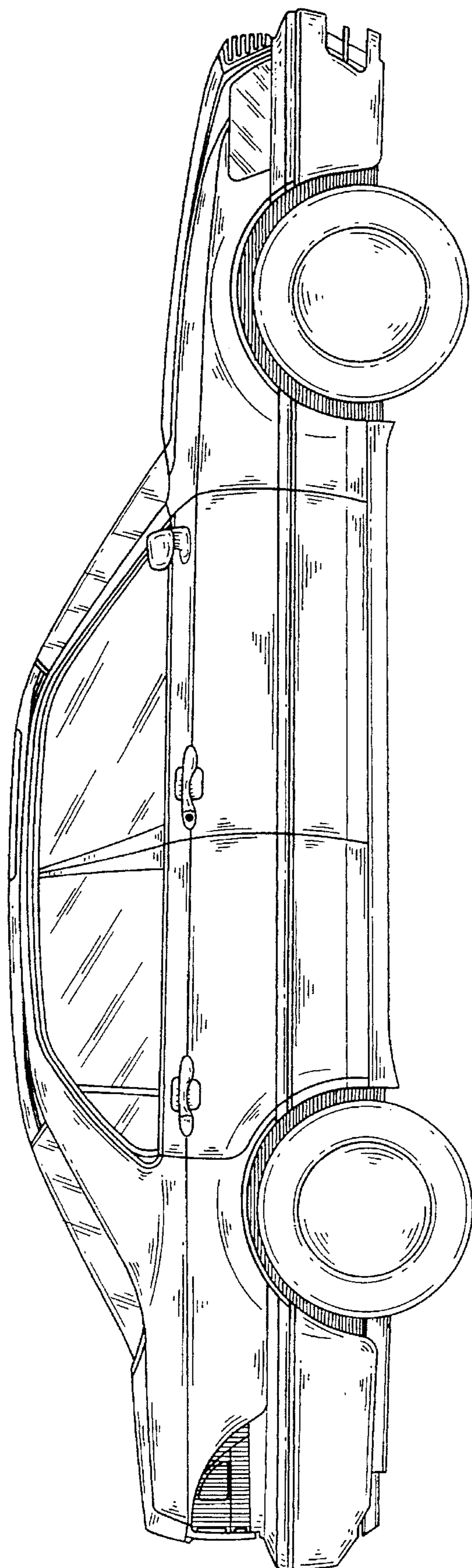

FIG. 3

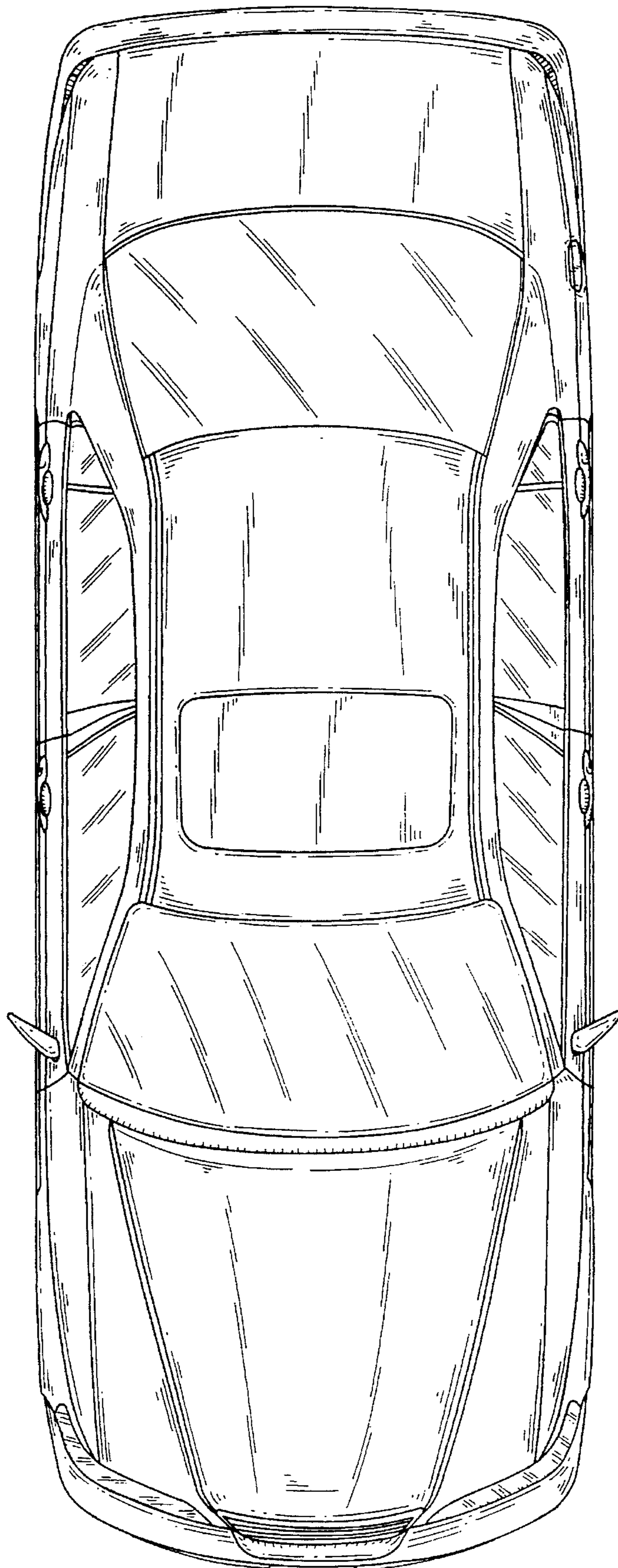

FIG. 4

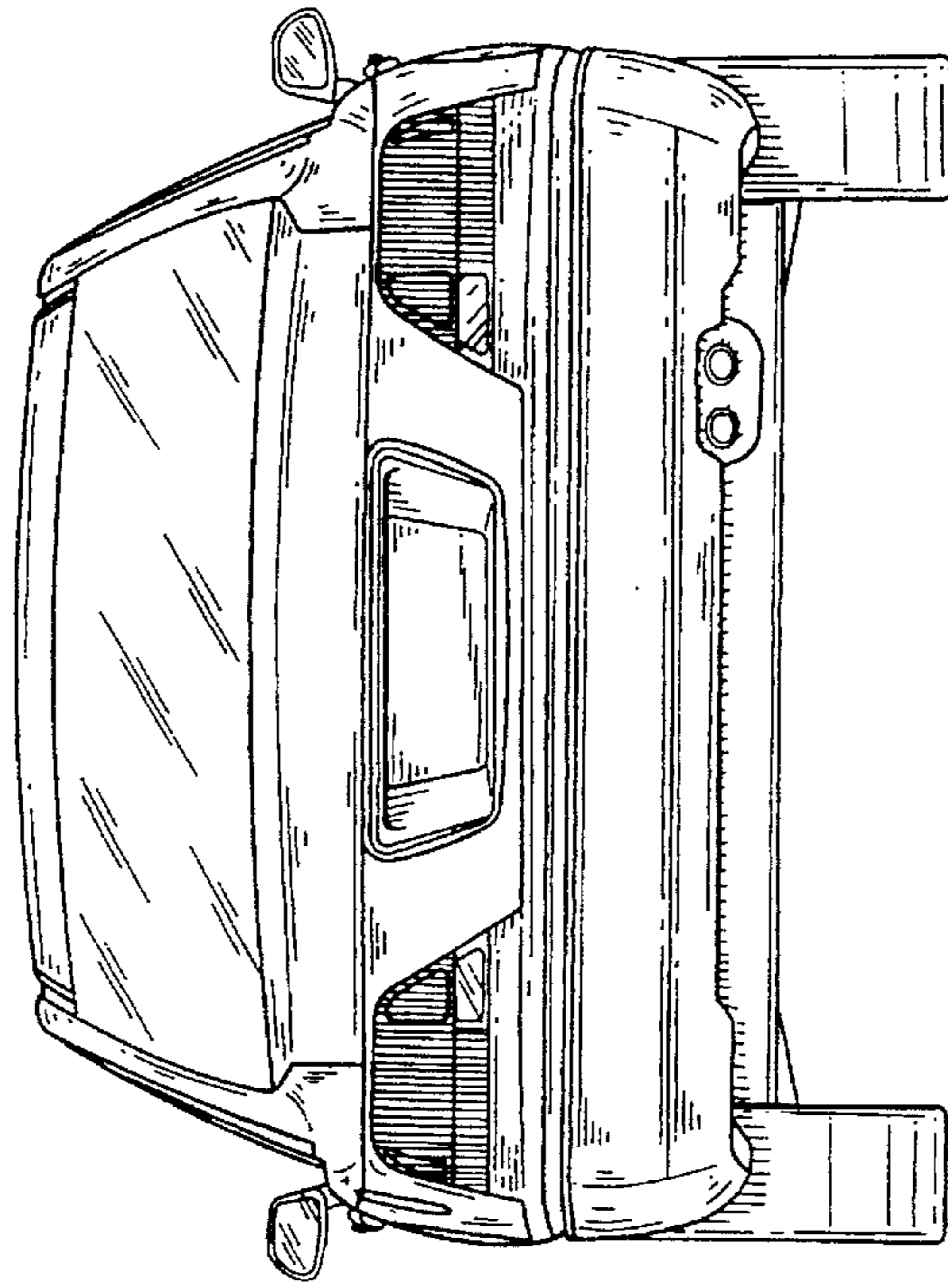

FIG. 6

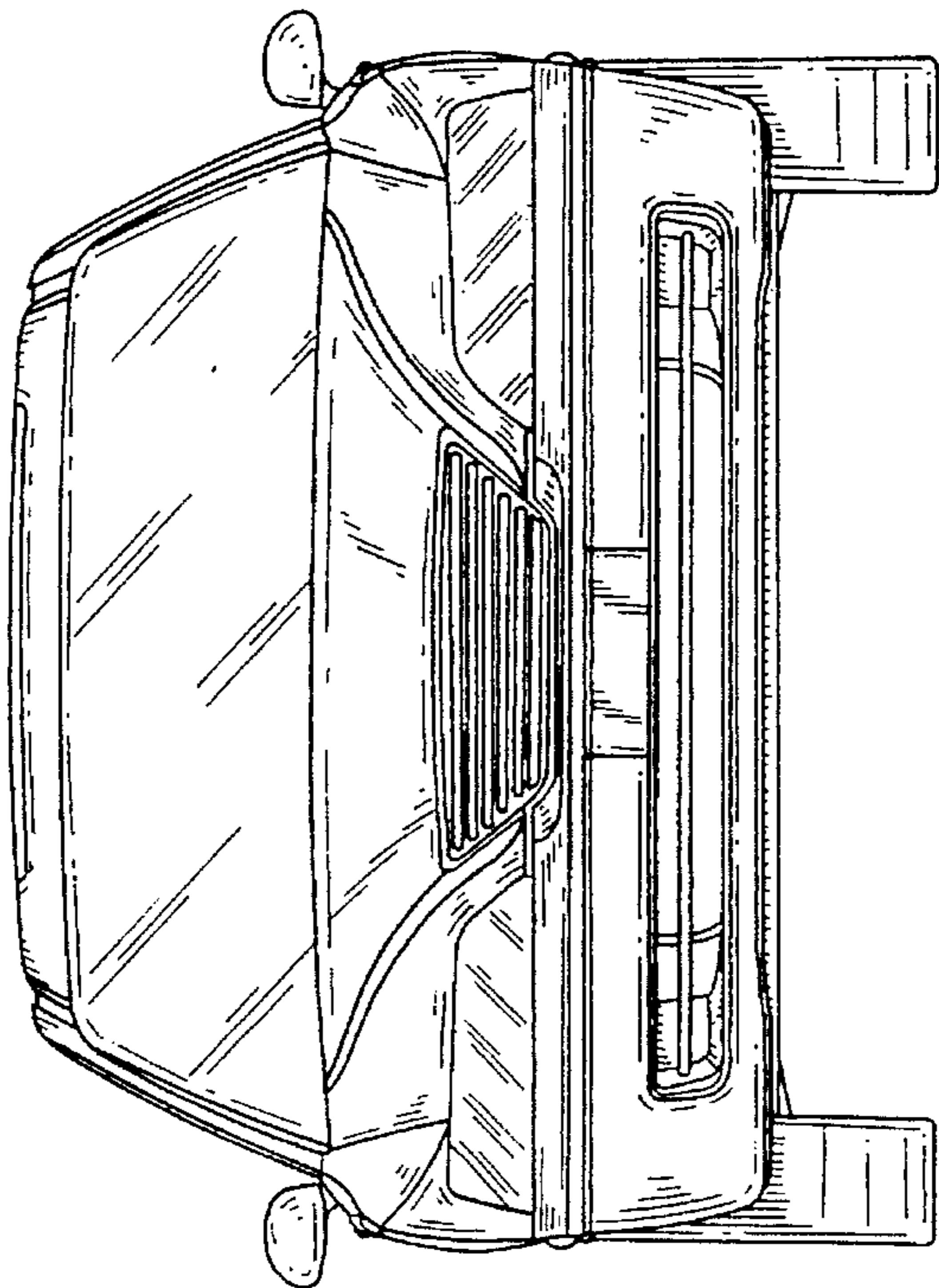

FIG. 5

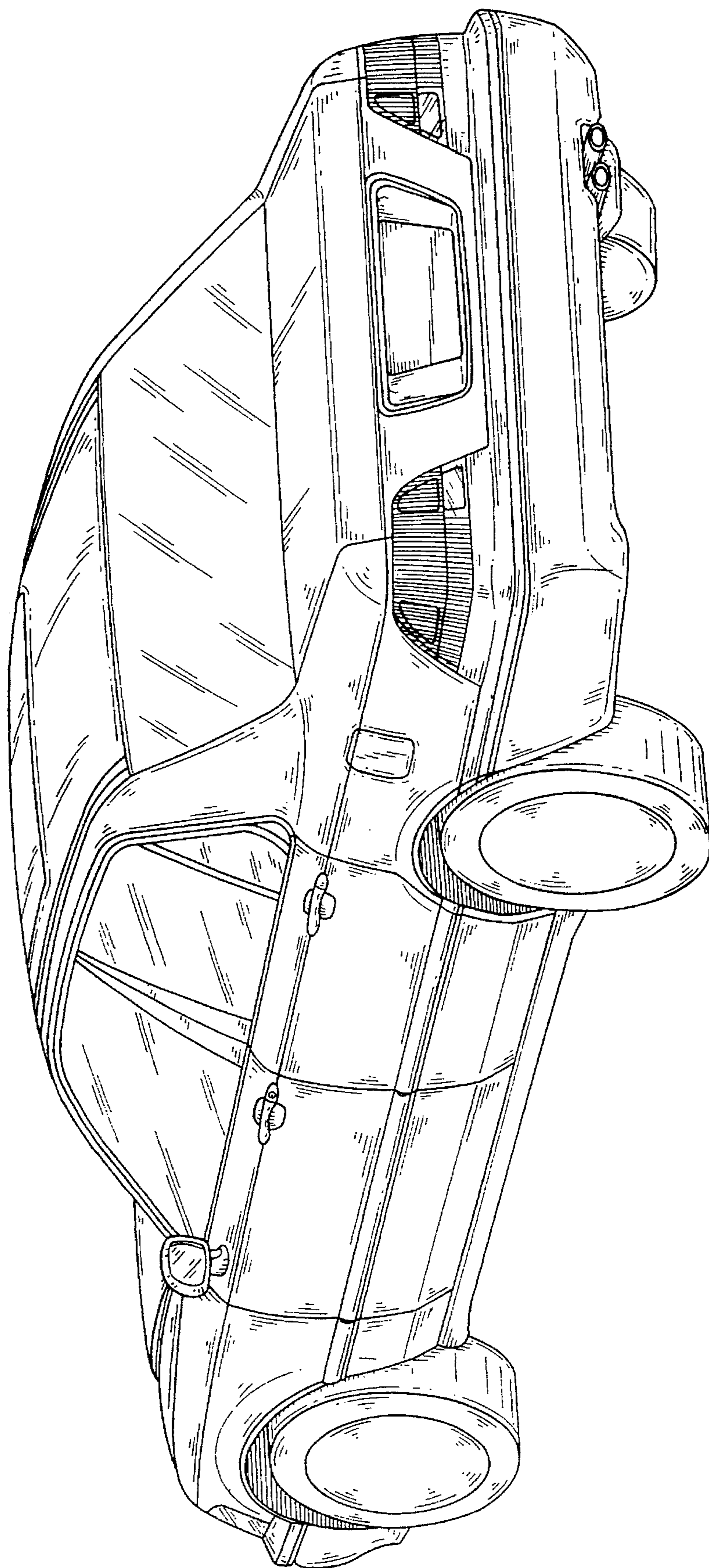

FIG. 7