



US00D373106S

United States Patent [19] Guidi

[11] Patent Number: Des. 373,106

[45] Date of Patent: **Aug. 27, 1996

[54] **FLEXIBLE STORAGE CONTAINER FOR CARGO BED OF A PICKUP TRUCK**

[75] Inventor: **Randolph J. Guidi**, Stockton, Calif.

[73] Assignee: **The Buffalo Bag LLC**, Stockton, Calif.

[**] Term: **14 Years**

[21] Appl. No.: **24,650**

[22] Filed: **Jun. 17, 1994**

[52] U.S. Cl. **D12/423**

[58] Field of Search D12/423, 221,
D12/401; D3/243, 290; 224/320-329, 541,
404; 296/3, 165, 26, 100, 37.1, 37.6-37.8;
150/166, 167

[56] **References Cited**

U.S. PATENT DOCUMENTS

D. 269,923	8/1983	Carrier et al.	D3/290
D. 273,669	3/1984	Forbes	D12/405
3,871,700	3/1975	Brownlee	296/26
4,101,062	7/1982	Lazar	296/37.7
5,299,849	4/1994	Cook et al.	296/100
5,335,960	8/1994	Benignu, Jr.	296/165
5,423,587	6/1995	Ingram	296/3

OTHER PUBLICATIONS

J C Whitney & Co Catalog, No 579E, p. 64, ©1995, the car top carrier bag.

Primary Examiner—Melody N. Brown

Attorney, Agent, or Firm—Lothrop & West

[57] **CLAIM**

The ornamental design for a flexible storage container for cargo bed of a pickup truck, as shown and described.

DESCRIPTION

FIG. 1 is a right rear perspective view of a flexible storage container for cargo bed of a pickup truck, showing my new design, with the top panels zippered together and the triangular panel in open position to provide access to the interior of the container;

FIG. 2 is a top plan view thereof, with all panels zippered together and the zipper intersection sealing flap closed;

FIG. 3 is a bottom plan thereof;

FIG. 4 is a side elevational view thereof, the opposite side being a mirror image;

FIG. 5 is a rear elevational view thereof;

FIG. 6 is a front elevational view thereof; and,

FIG. 7 is a rear elevational view thereof showing the container folded forwardly and buckled to contain a partial load, the rear tie-down straps being tucked into the folds and therefore not visible.

1 Claim, 3 Drawing Sheets

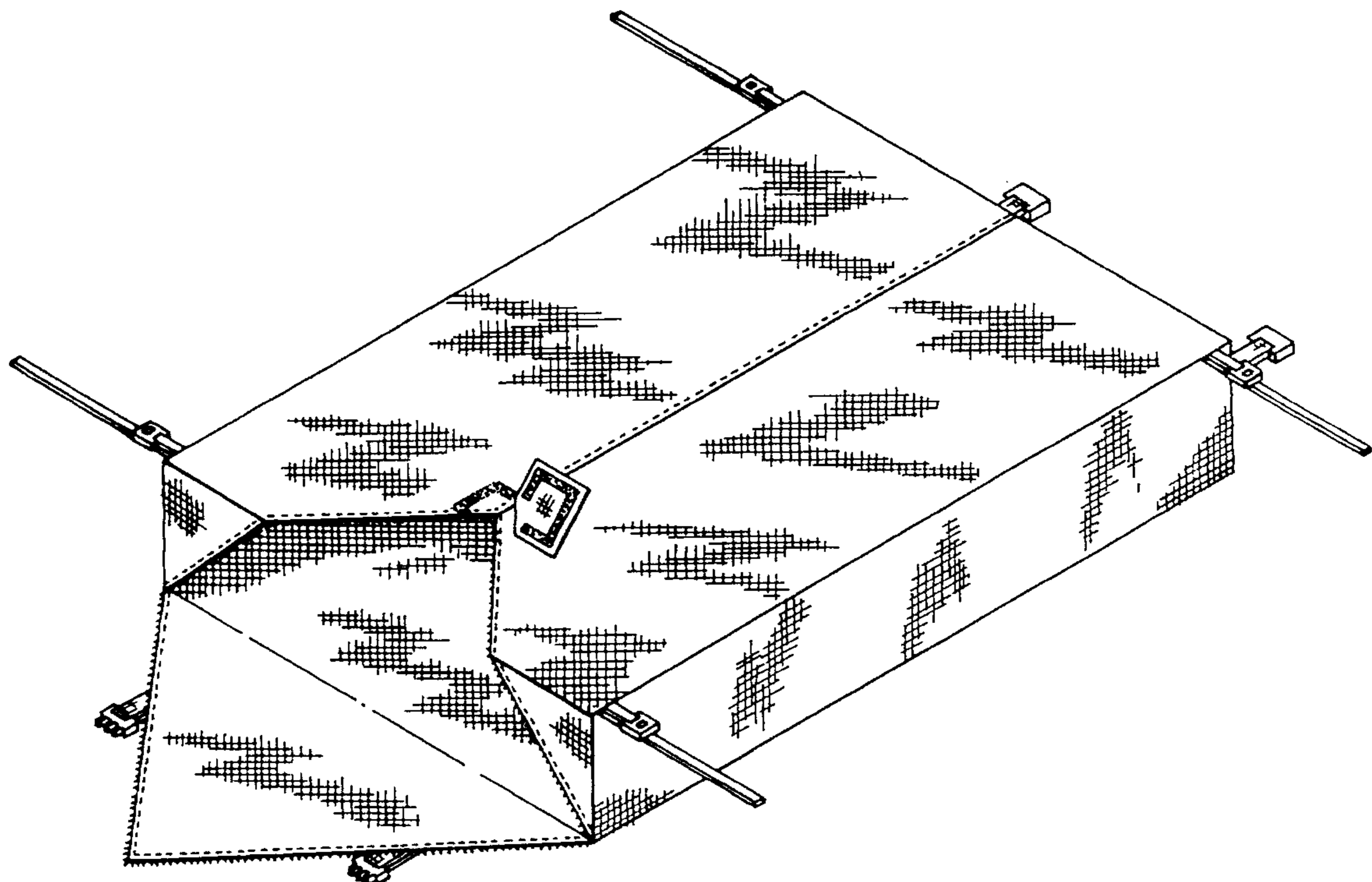

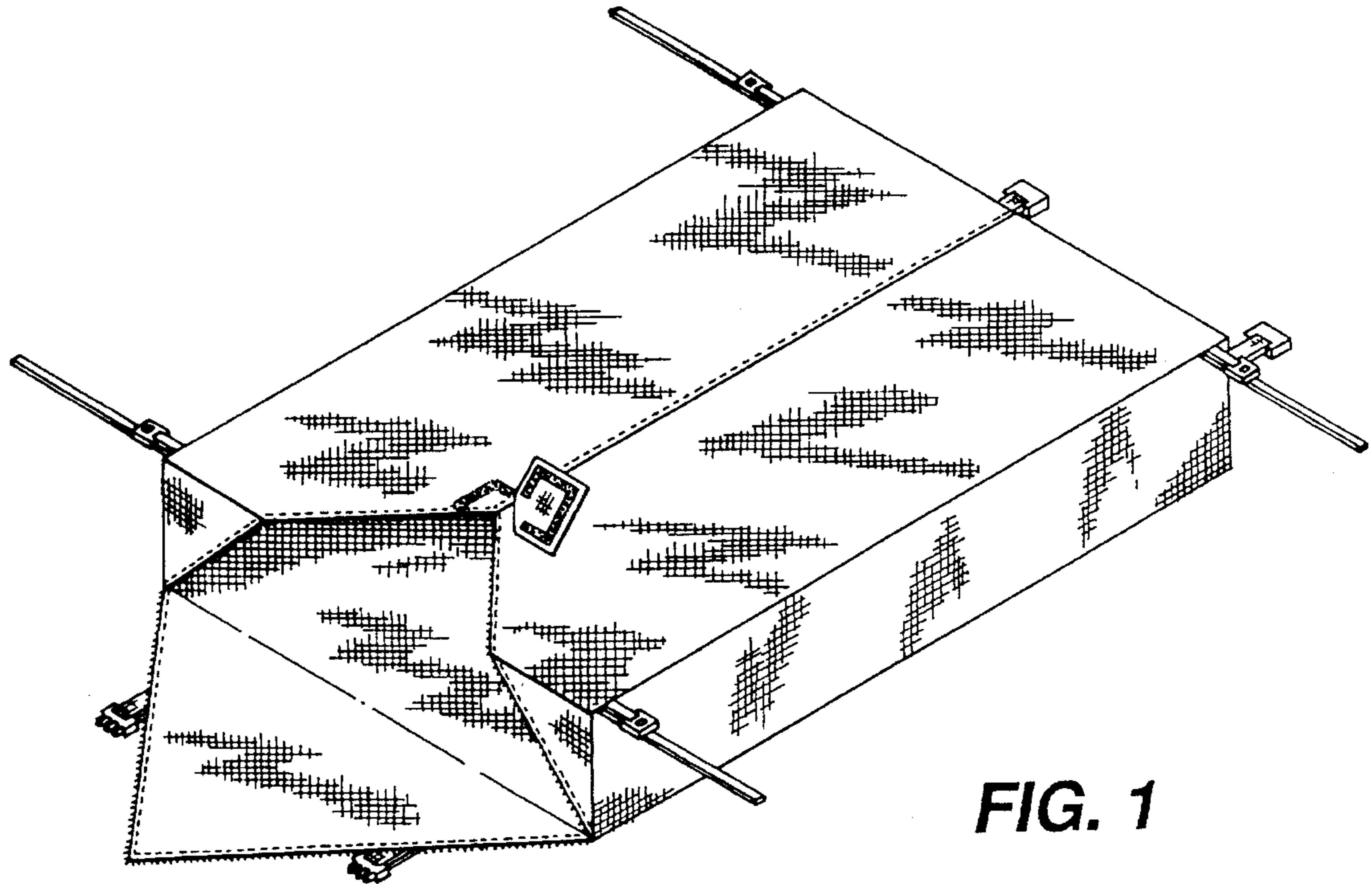

FIG. 1

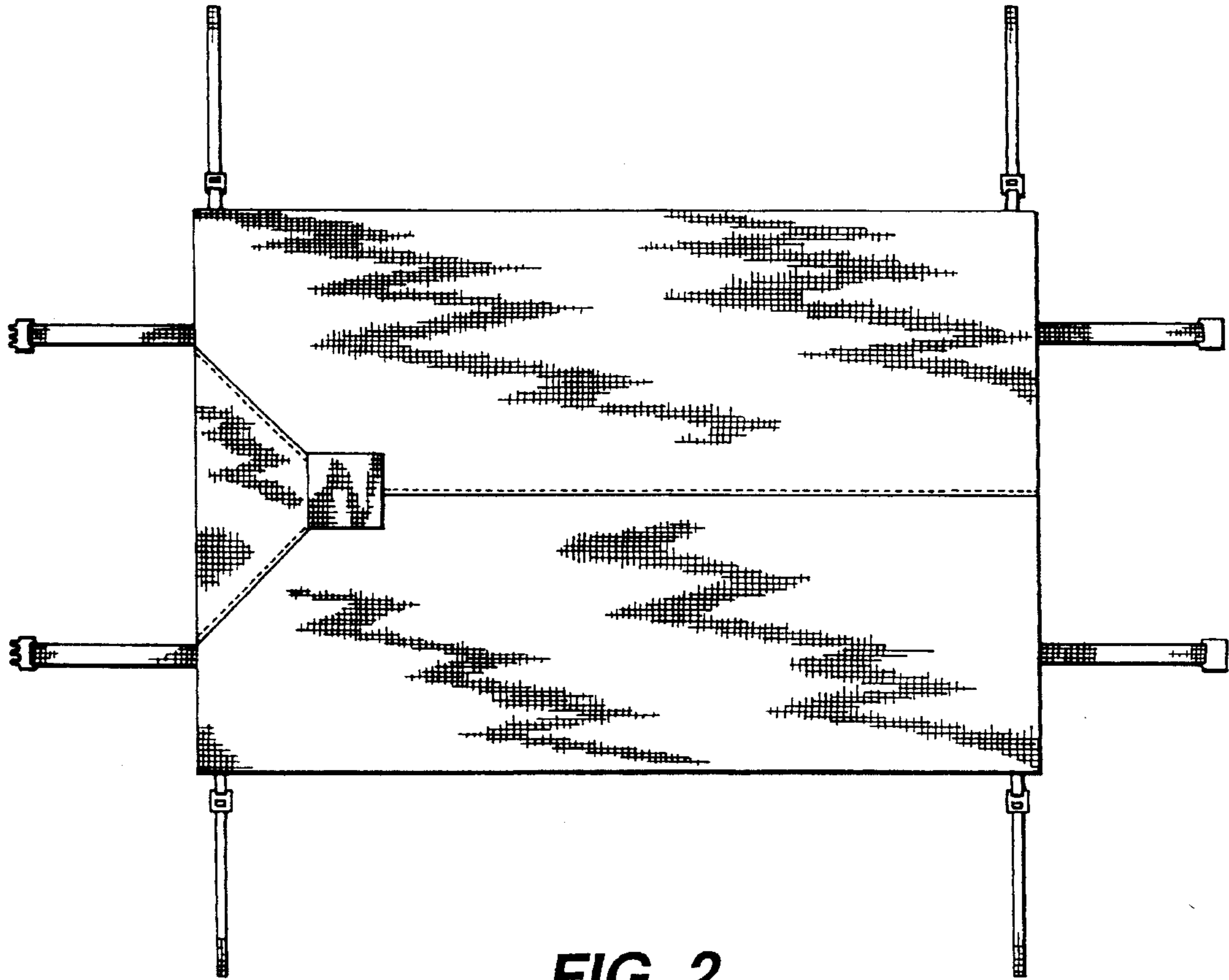

FIG. 2

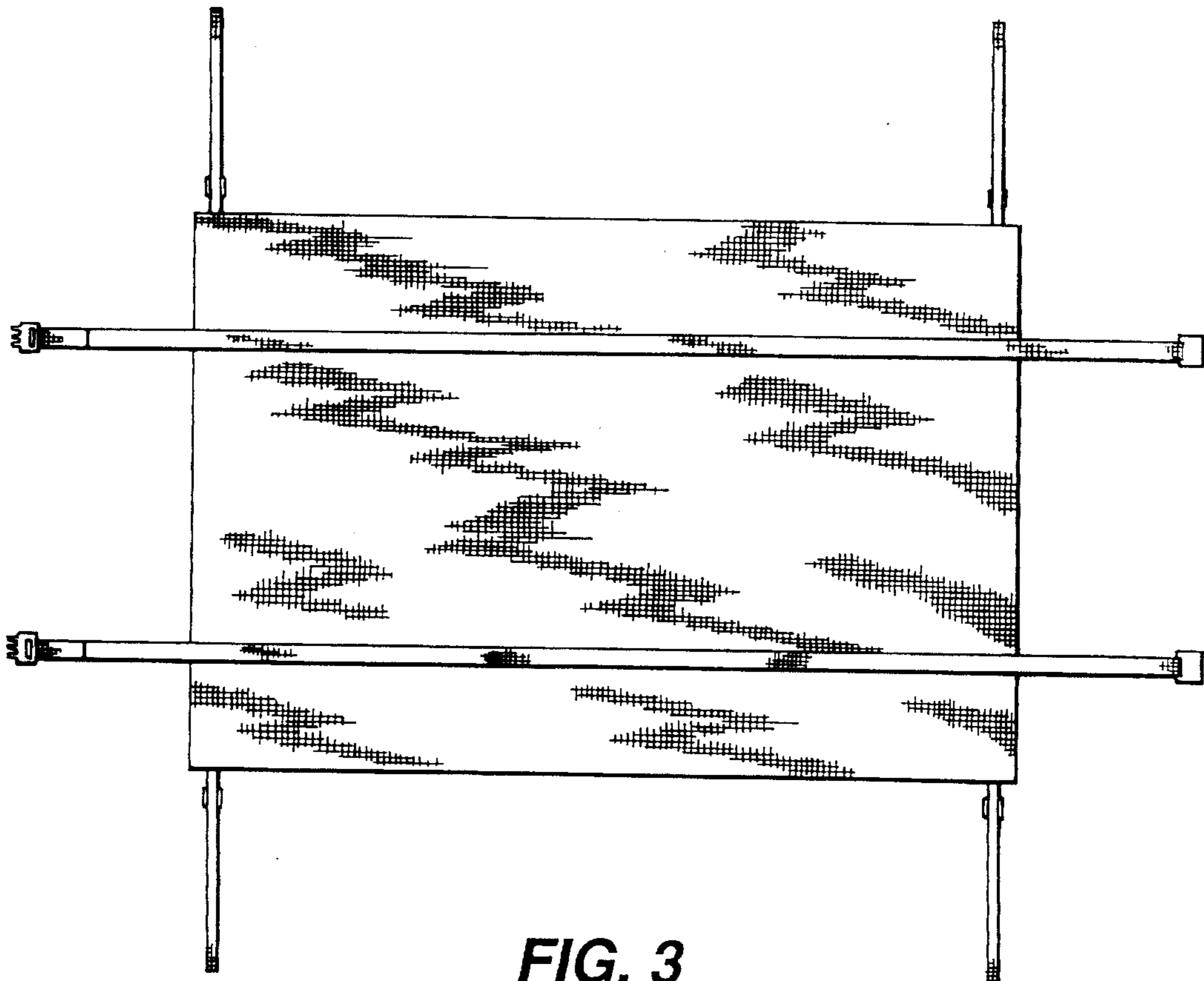

FIG. 3

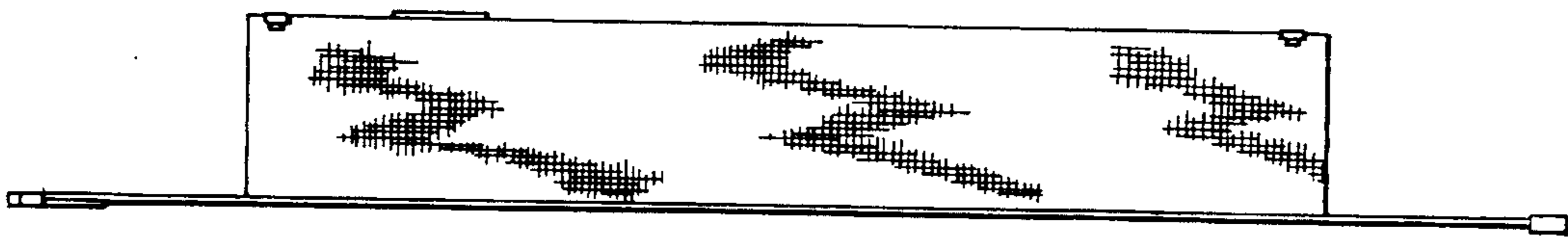

FIG. 4

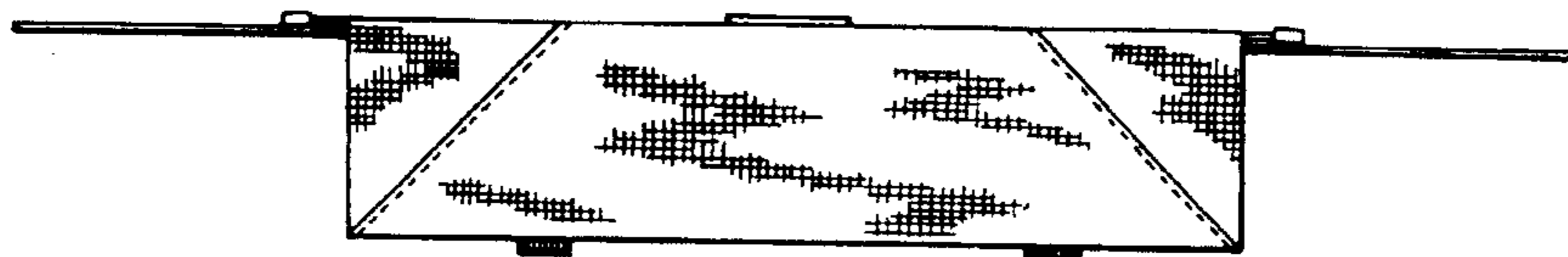

FIG. 5

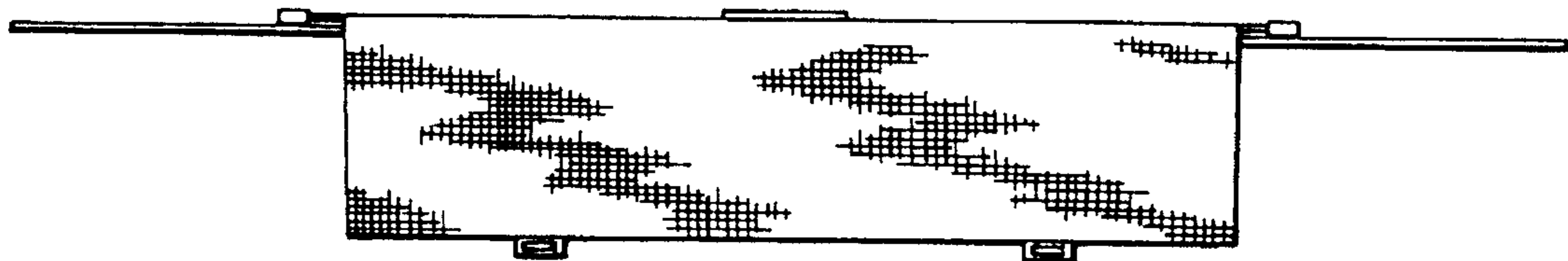

FIG. 6

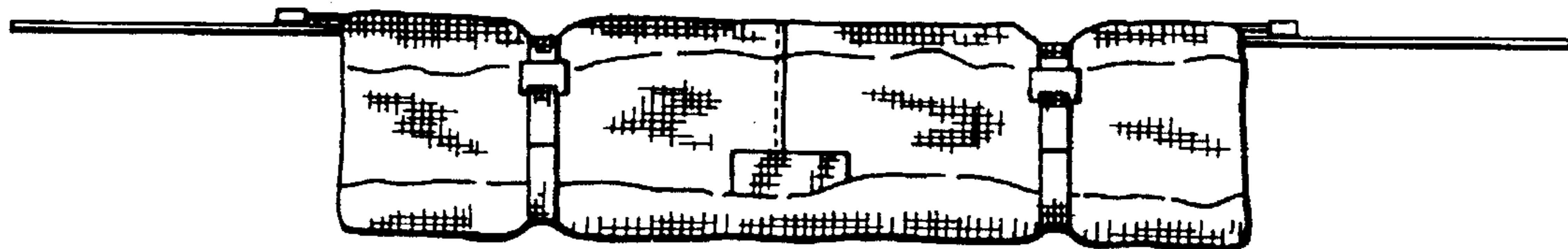

FIG. 7