



US00D372926S

United States Patent [19]

[11] Patent Number: Des. 372,926

Matsumura

[45] Date of Patent: **Aug. 20, 1996

[54] VIDEO CAMERA WITH VIDEO TAPE RECORDER

[75] Inventor: Yoshiyuki Matsumura, Yokosuka, Japan

[73] Assignee: Canon Kabushiki Kaisha, Tokyo, Japan

[**] Term: 14 Years

[21] Appl. No.: 38,726

[22] Filed: May 12, 1995

[30] Foreign Application Priority Data

Nov. 14, 1994 [JP] Japan 6-34664

[52] U.S. Cl. D16/202

[58] Field of Search D16/200, 202, D16/203-206, 208; 348/373-376; 352/34, 242, 243; 354/82, 288; 358/906

[56] References Cited

U.S. PATENT DOCUMENTS

D. 288,811	3/1987	Kurokawa et al.	D16/202
D. 289,645	5/1987	Kondo	D14/78
D. 294,570	3/1988	Kurokawa et al.	D16/202
D. 305,240	12/1989	Kondoh	D16/202
D. 316,419	4/1991	Matsumura	D16/202
D. 316,420	4/1991	Tanaka	D16/202
D. 322,266	12/1991	Ichiyoshi	D16/202
D. 322,267	12/1991	Matsumura	D16/202
D. 322,448	12/1991	Kondo	D16/202
D. 327,698	7/1992	Masuda	D16/202
D. 331,767	12/1992	Yoshida	D16/202
D. 331,935	12/1992	Tanaka	D16/202

D. 331,936	12/1992	Ishikawa	D16/202
D. 332,108	12/1992	Kondo	D16/202
D. 336,910	6/1993	Yoshida	D16/202
D. 337,340	7/1993	Tanaka	D16/202
D. 337,341	7/1993	Masuda	D16/202
D. 337,597	7/1993	Yoshida	D16/202
D. 337,778	7/1993	Matsumura	D16/202
D. 342,084	12/1993	Ishikawa	D16/202
D. 345,172	3/1994	Ishikawa	D16/202
D. 350,360	9/1994	Masuda	D16/202
D. 356,806	3/1995	Kim	D16/202
D. 362,452	9/1995	Matsumura	D16/202

OTHER PUBLICATIONS

HFD Oct. 17, 1988 p. 146 (Sony's CCD-V11).

Primary Examiner—Ted Shooman

Assistant Examiner—Adir Aronovich

Attorney, Agent, or Firm—Fitzpatrick, Cella, Harper & Scinto

[57] CLAIM

The ornamental design for a video camera with video tape recorder, as shown and described.

DESCRIPTION

FIG. 1 is a front elevational view of a video camera with video tape recorder showing my new design; FIG. 2 is a rear elevational view thereof; FIG. 3 is a top plan view thereof; FIG. 4 is a bottom plan view thereof; FIG. 5 is a left side elevational view thereof; FIG. 6 is a right side elevational view thereof; and, FIG. 7 is a perspective view thereof.

1 Claim, 2 Drawing Sheets

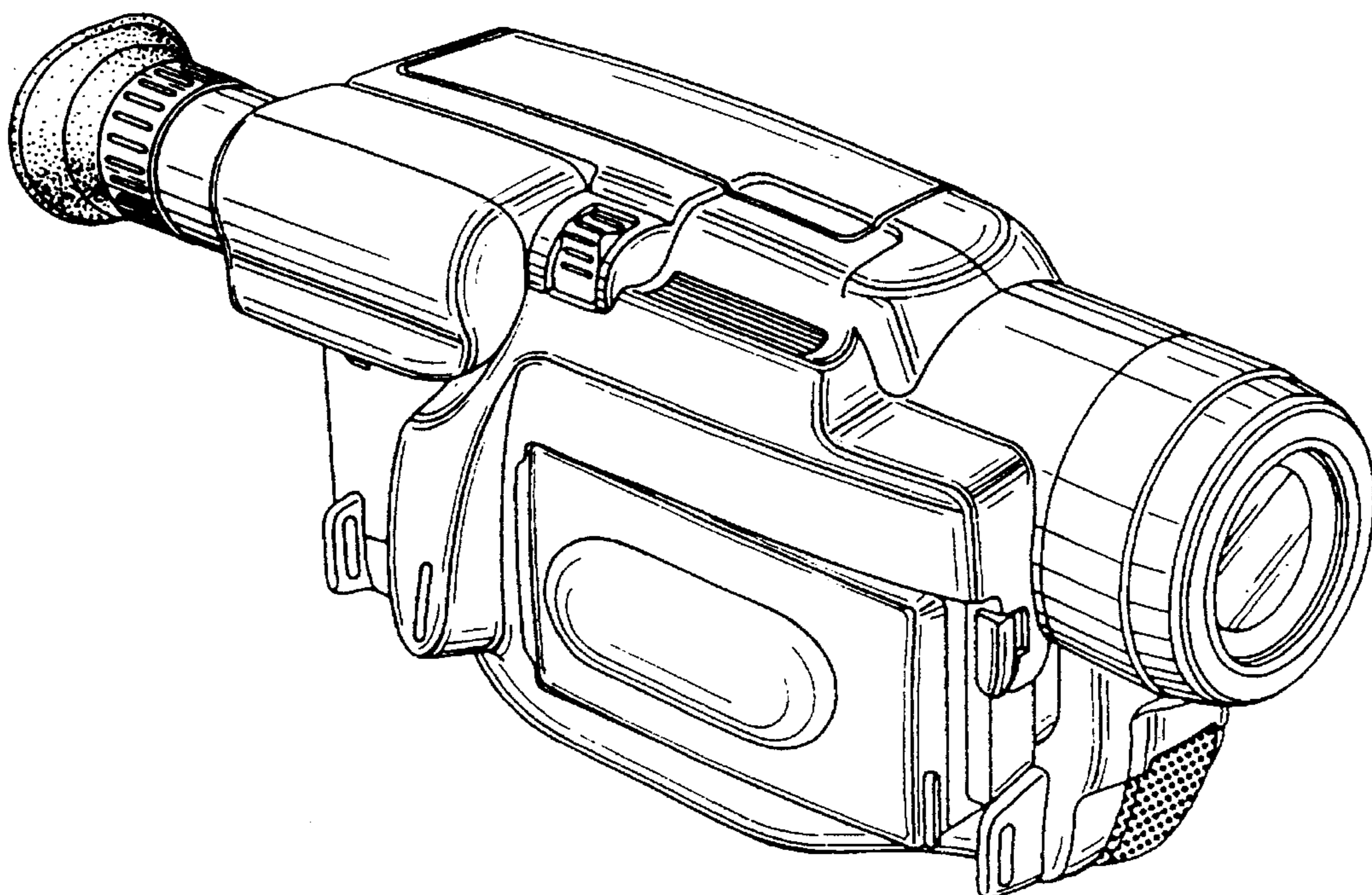

FIG. 1

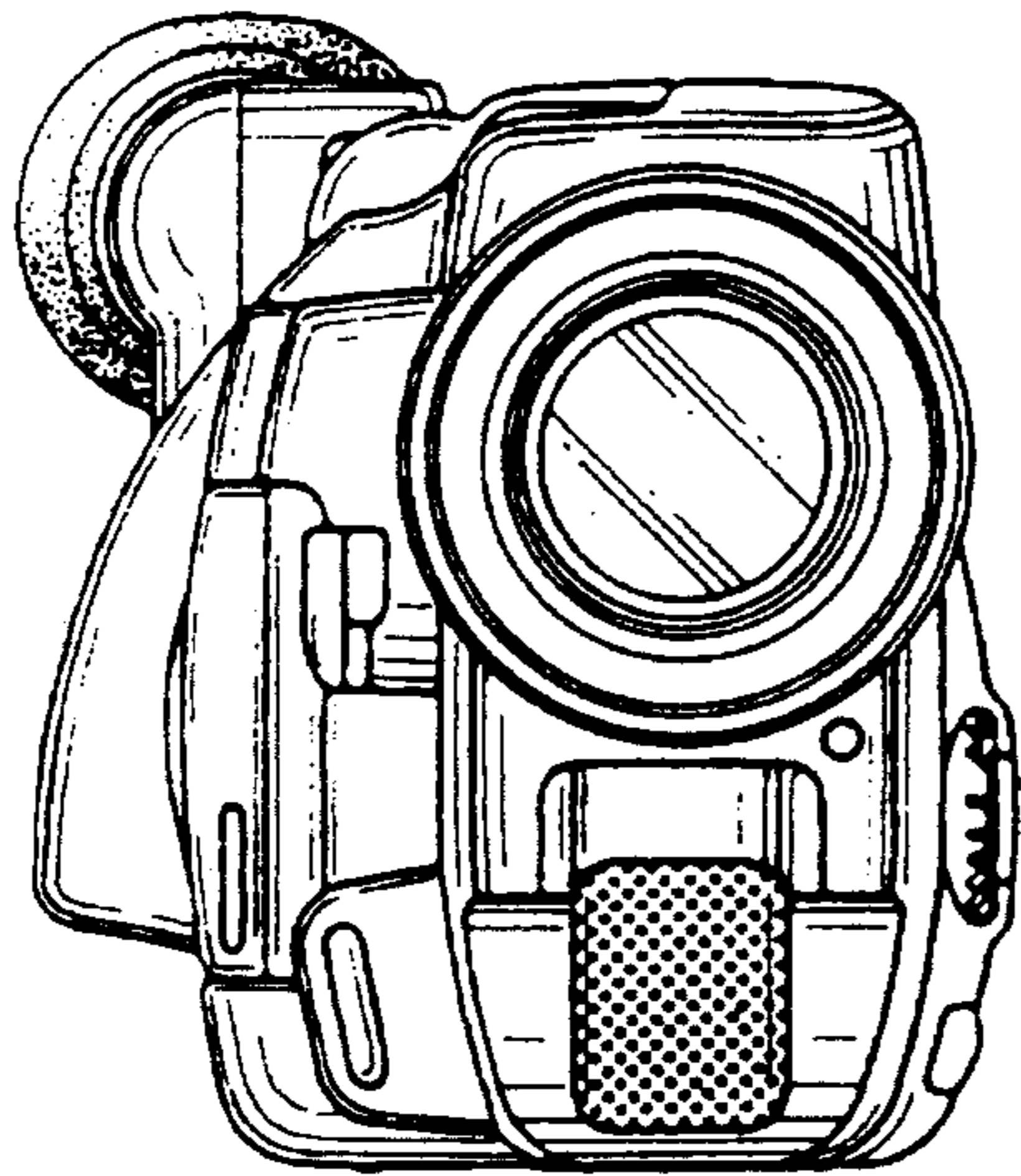

FIG. 2

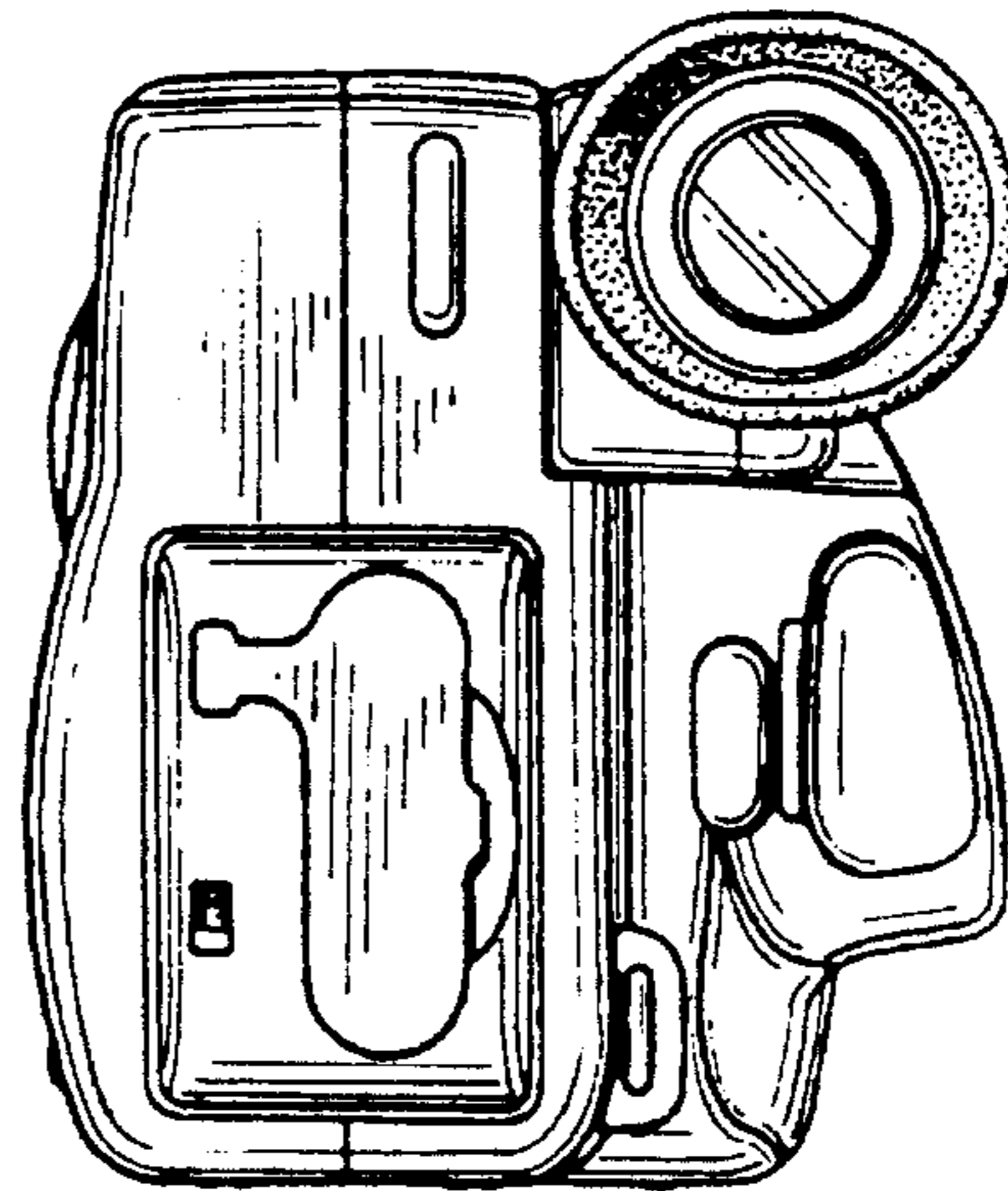

FIG. 3

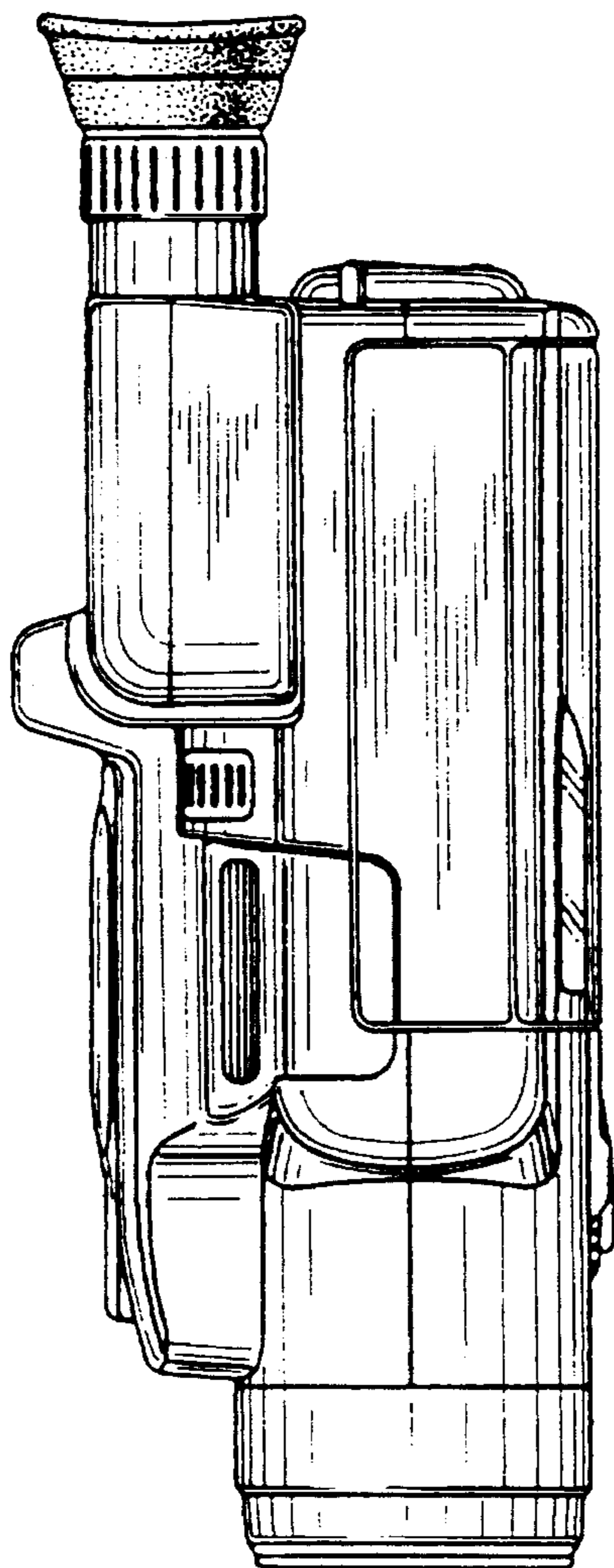

FIG. 4

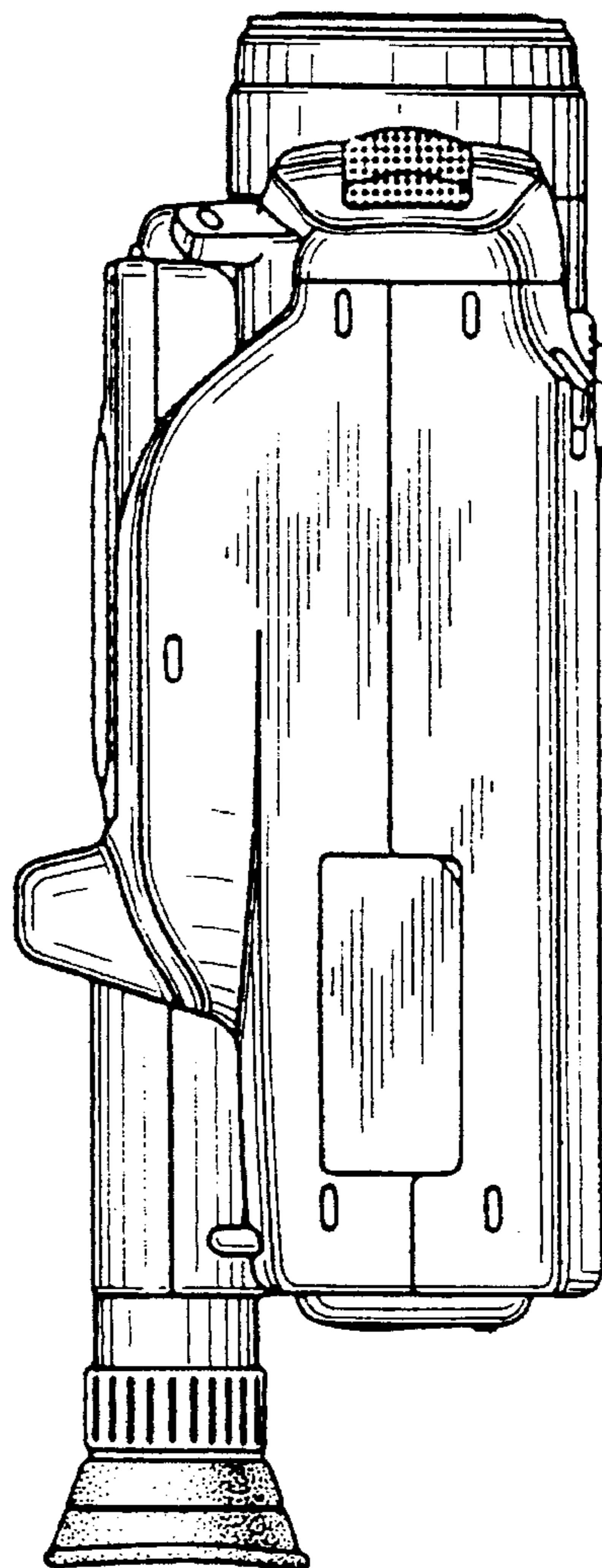

FIG. 5

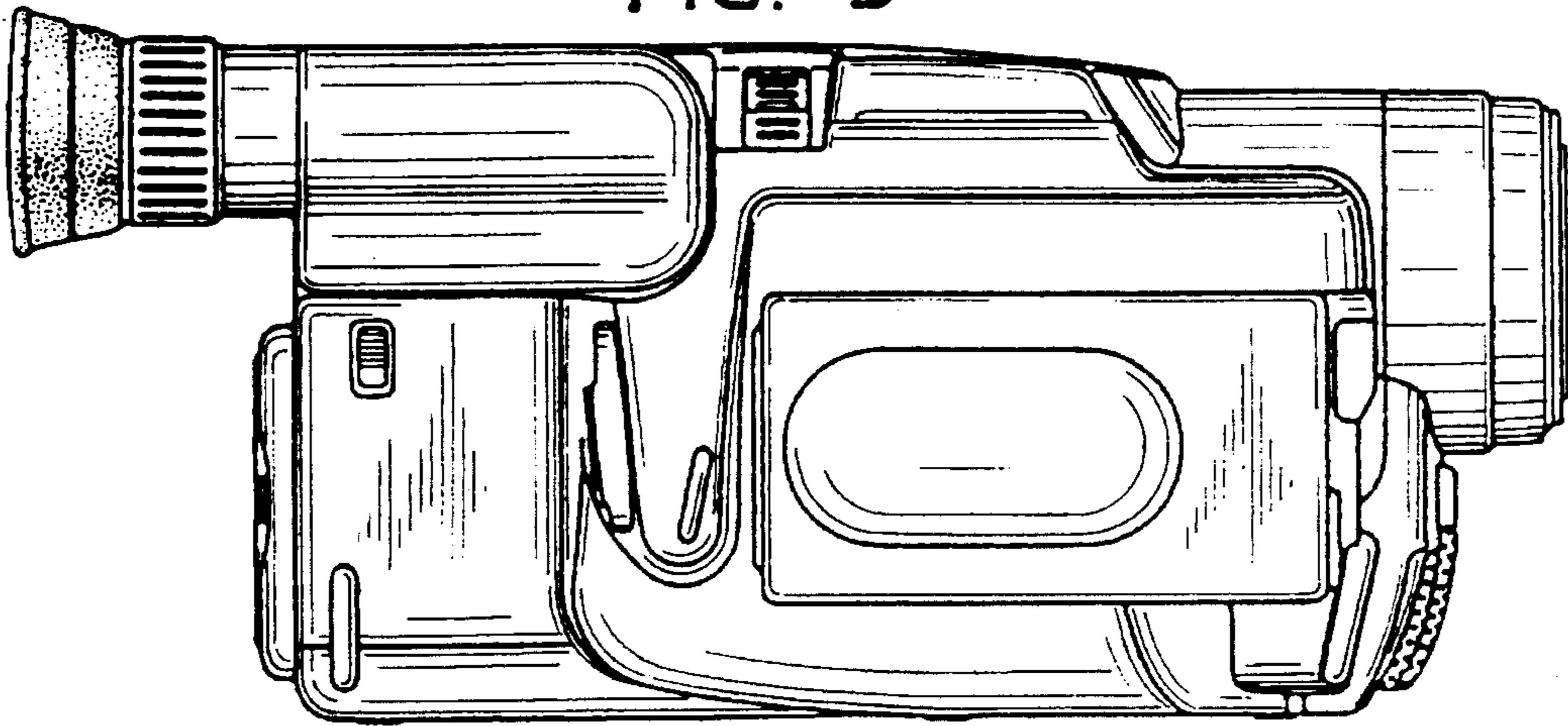

FIG. 6

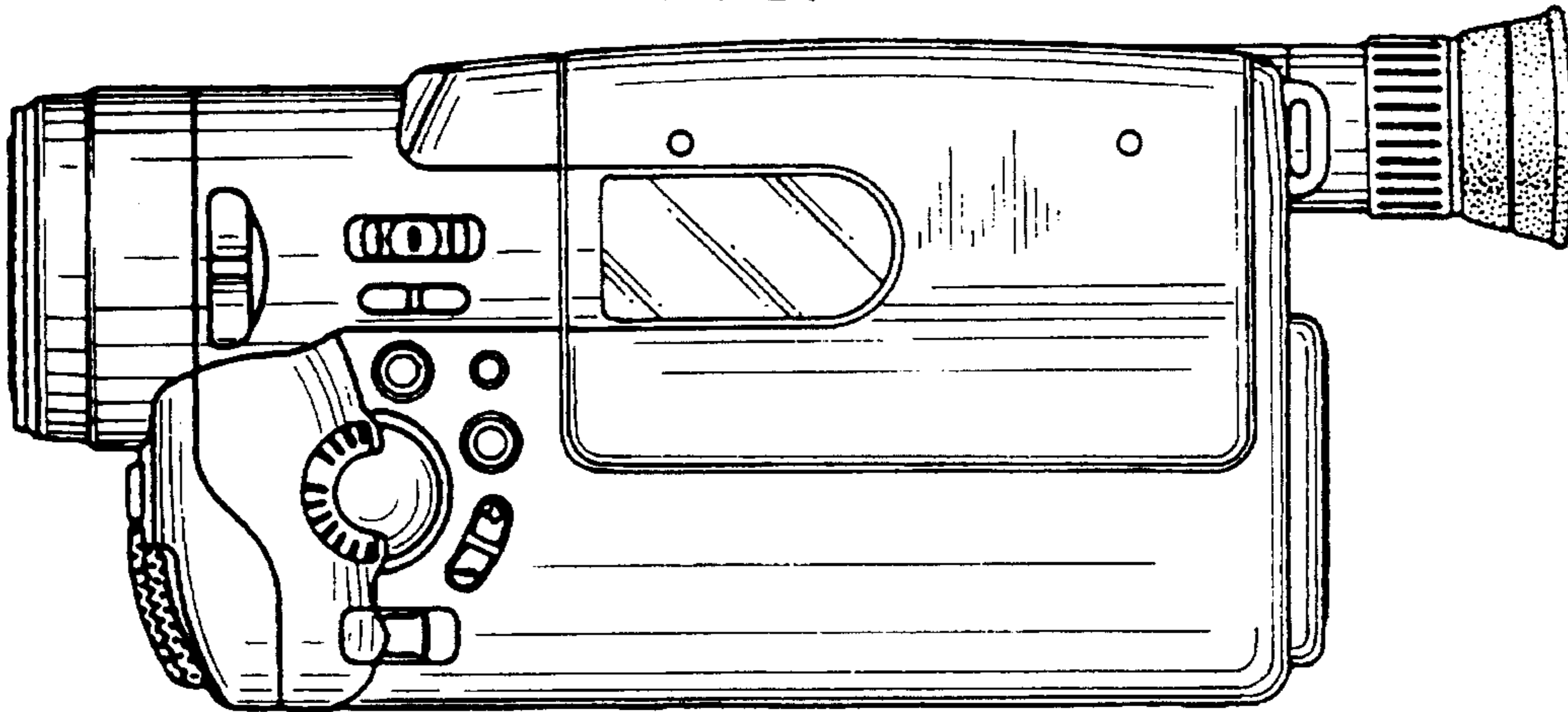

FIG. 7

