



US00D372892S

United States Patent [19]
McCoy et al.

[11] **Patent Number: Des. 372,892**
[45] **Date of Patent: **Aug. 20, 1996**

[54] **STEP BUMPER HITCH RECEIVER**

5,378,008 1/1995 McCrossen 280/507

[75] Inventors: **Richard McCoy**, Granger, Ind.;
Marvin L. Hanson, Vandalia; **Jon L. Krager**, Cassopolis, both of Mich.

OTHER PUBLICATIONS

Quality S. Hitch Manufacturing Sales Catalog; Feb. 1994; 16.
Hidden Hitch of America Inc. Caralogue; 1993; 15.
Eaz-Lift Spring Corporation Product Catalog; 1993; 10.
Valley Industries Towing Products and Accessories Product Catalog; 1995; 17.
Shelton, Industries Product Catalog; 1993; 17.

[73] Assignee: **Reese Products, Inc.**, Elkhart, Ind.

[**] Term: **14 Years**

Primary Examiner—Melody N. Brown
Attorney, Agent, or Firm—King & Schickli

[21] Appl. No.: **42,614**

[22] Filed: **Aug. 14, 1995**

[52] **U.S. Cl.** **D12/162**

[58] **Field of Search** D12/162; 280/477,
280/507, 510, 511, 512, 513, 482

[57] **CLAIM**

The ornamental design for a step bumper hitch receiver, as shown.

[56] **References Cited**

U.S. PATENT DOCUMENTS

D. 264,697	6/1982	Monteith	D12/162
D. 274,803	7/1984	Hughes	D12/126
D. 280,311	8/1985	Pawsat	D12/117
D. 296,886	7/1988	Young, Jr.	D12/126
D. 305,749	1/1990	Jorgensen	D12/117
D. 319,204	8/1991	McGrady	D12/162
D. 334,163	3/1993	McVey	D12/162
D. 349,875	8/1994	Blodgett	D12/162
D. 362,224	9/1995	McCoy et al.	D12/162
4,974,866	12/1990	Morgan	280/477
5,246,244	9/1993	Colibert	280/511

DESCRIPTION

FIG. 1 is a perspective view of the step bumper hitch receiver of the present invention;
FIG. 2 is a top plan view thereof;
FIG. 3 is a bottom plan view thereof;
FIG. 4 is a front elevational view thereof;
FIG. 5 is a rear elevational view thereof;
FIG. 6 is a left side elevational view thereof; and,
FIG. 7 is a right side elevational view thereof.

1 Claim, 2 Drawing Sheets

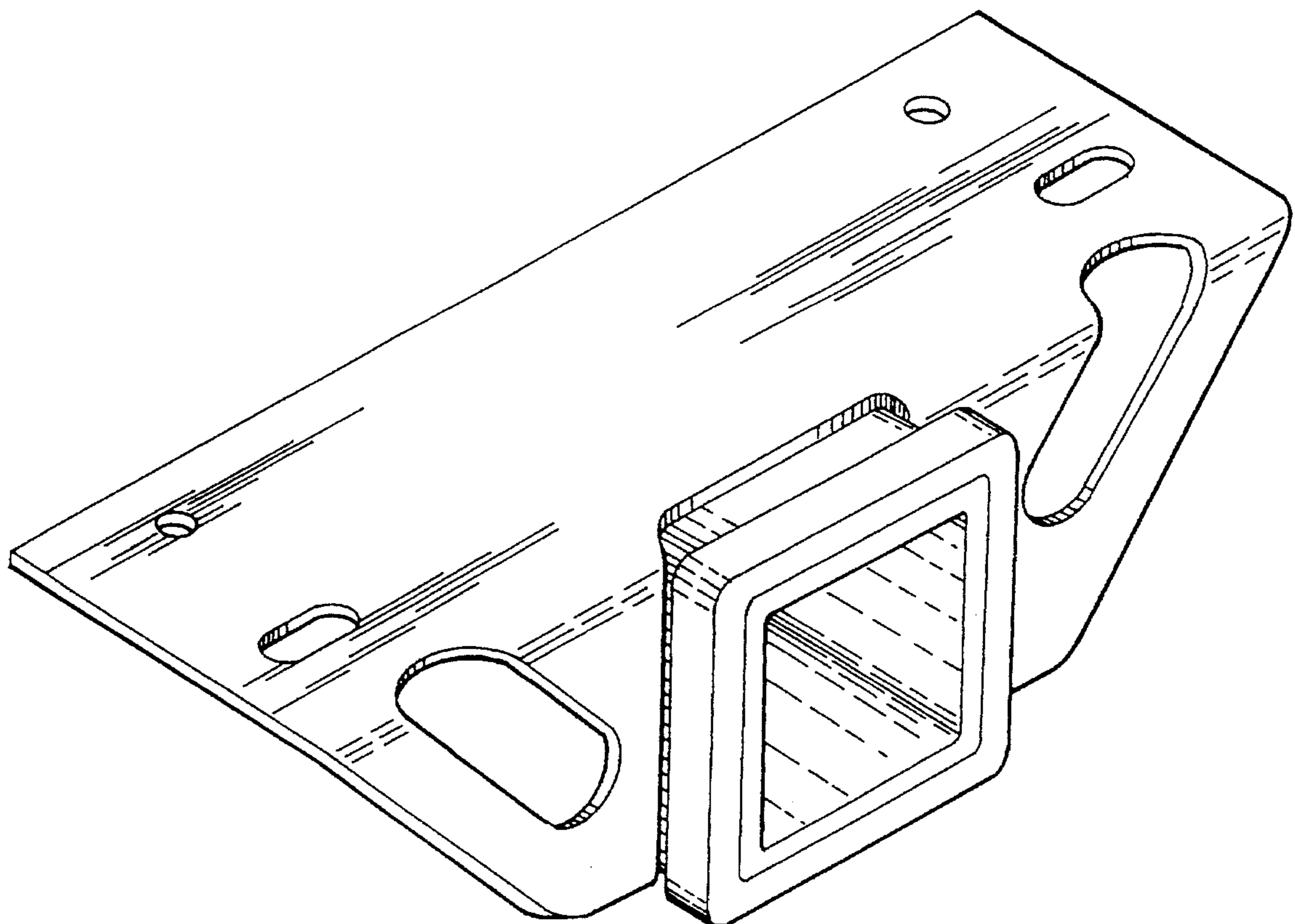

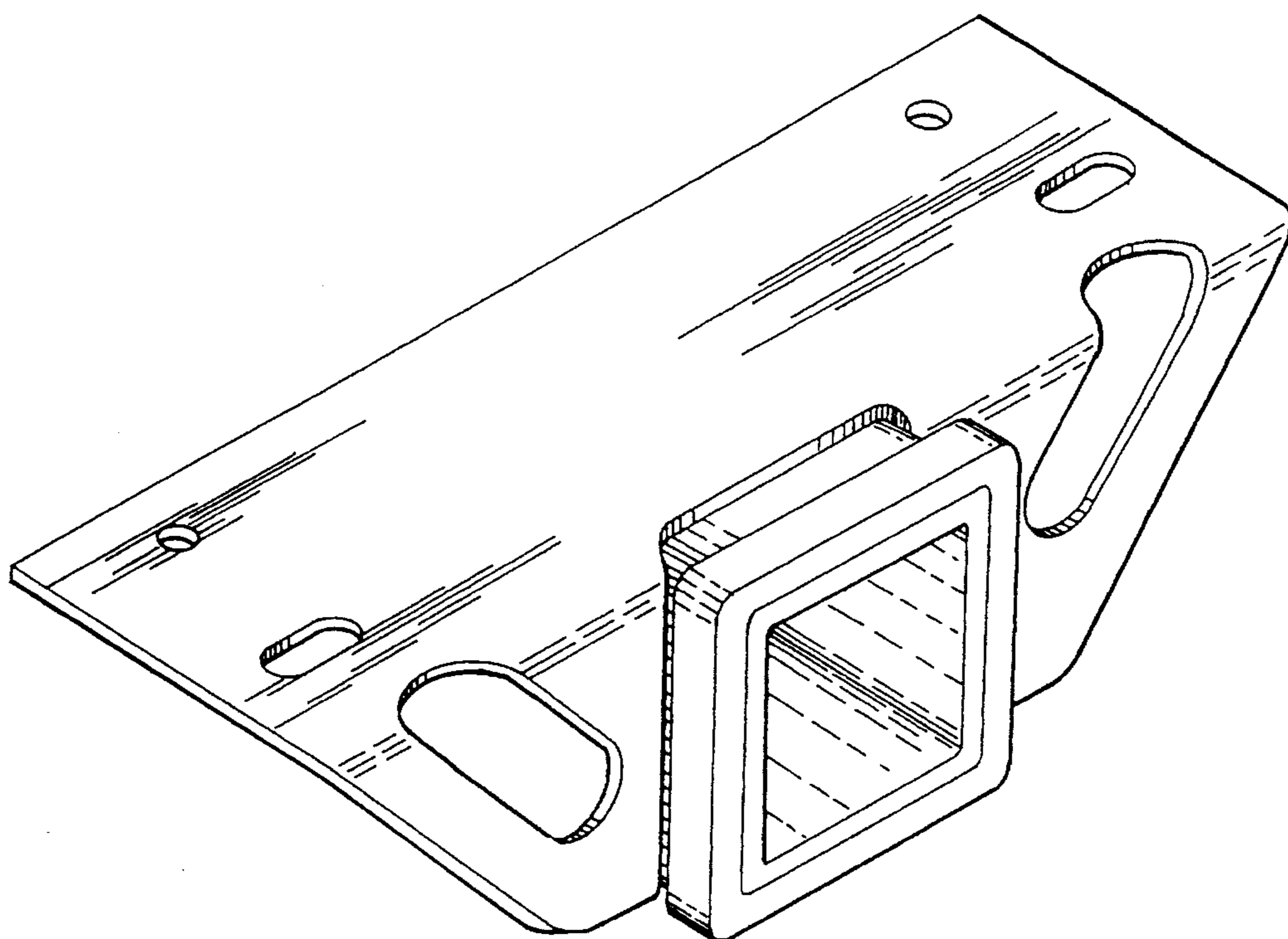

Fig 1

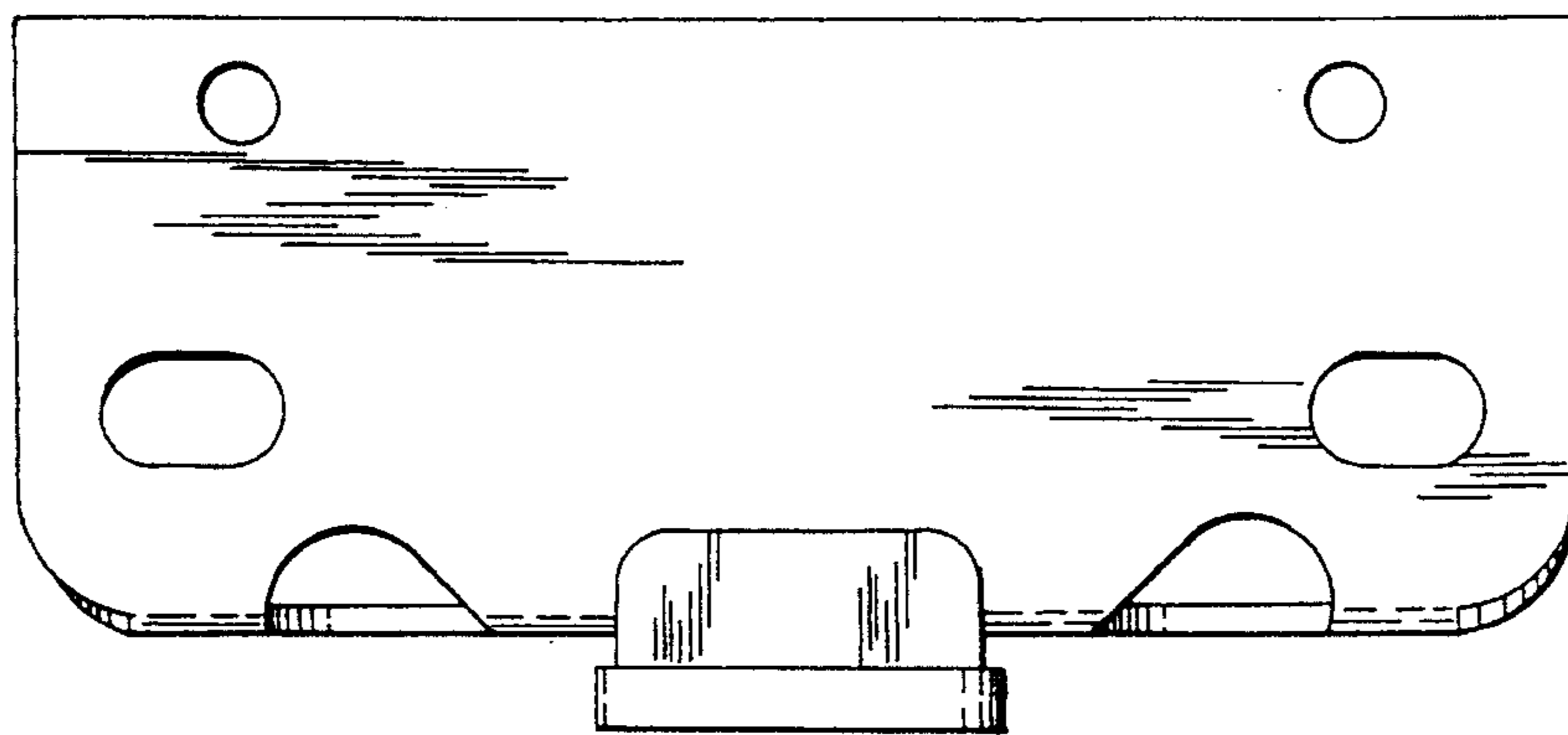

Fig 2

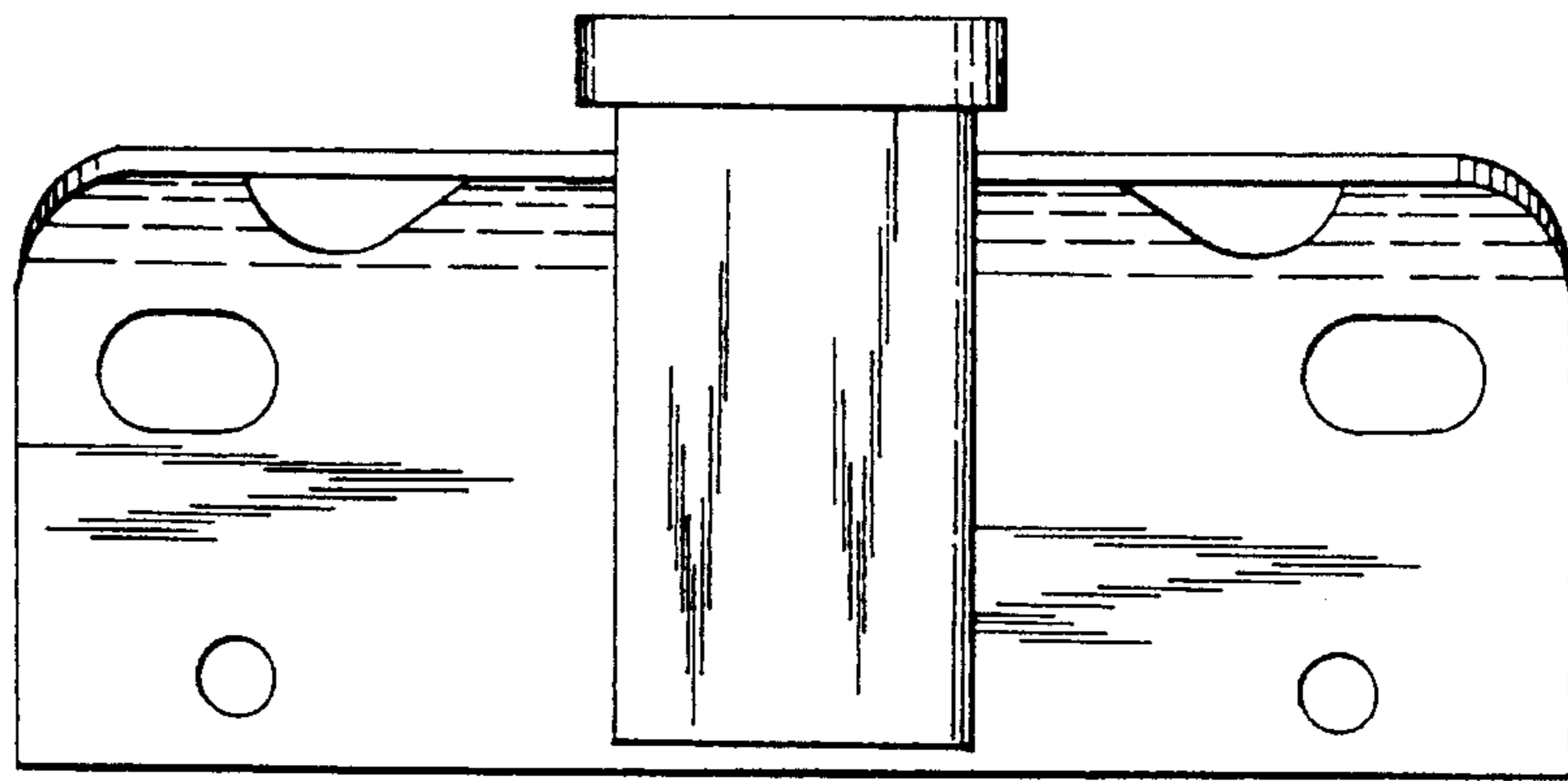

Fig. 3

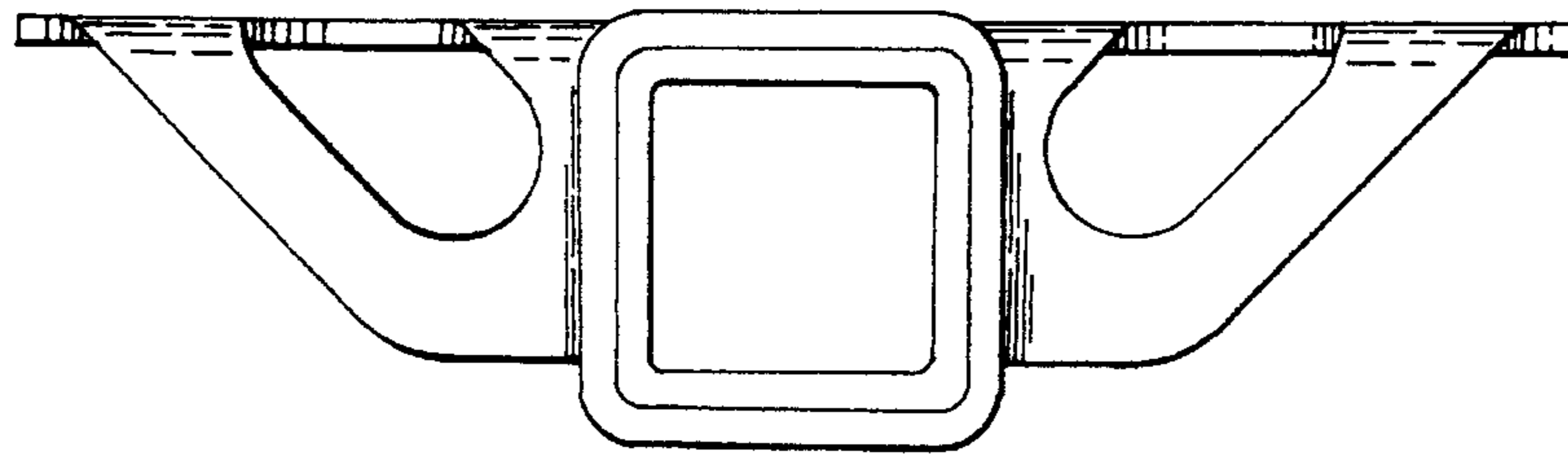

Fig. 4

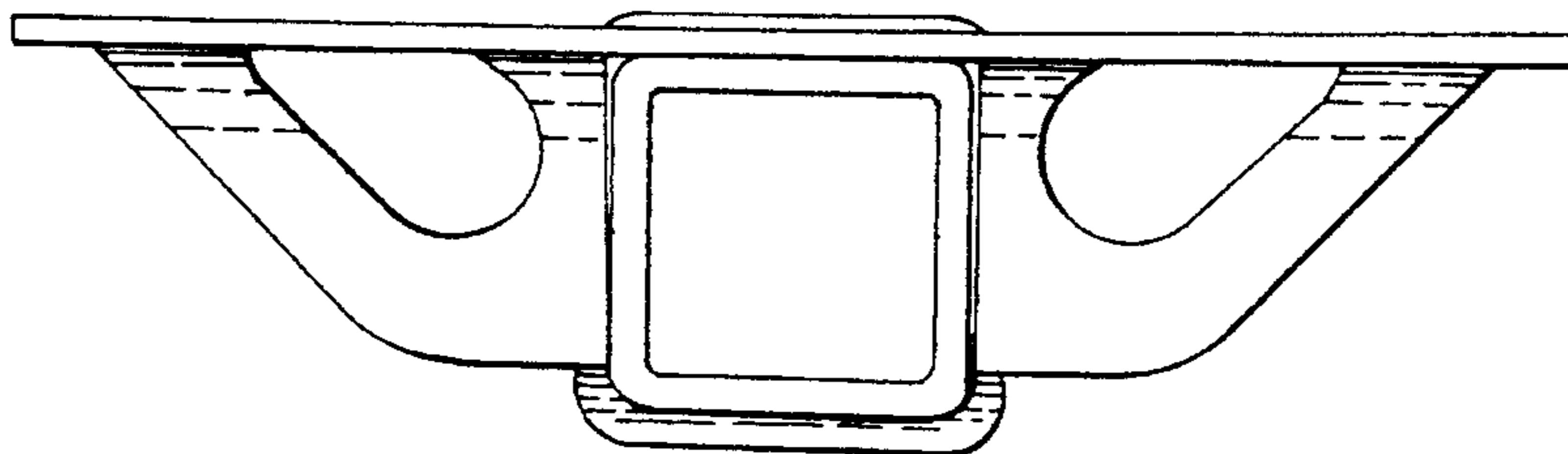

Fig. 5

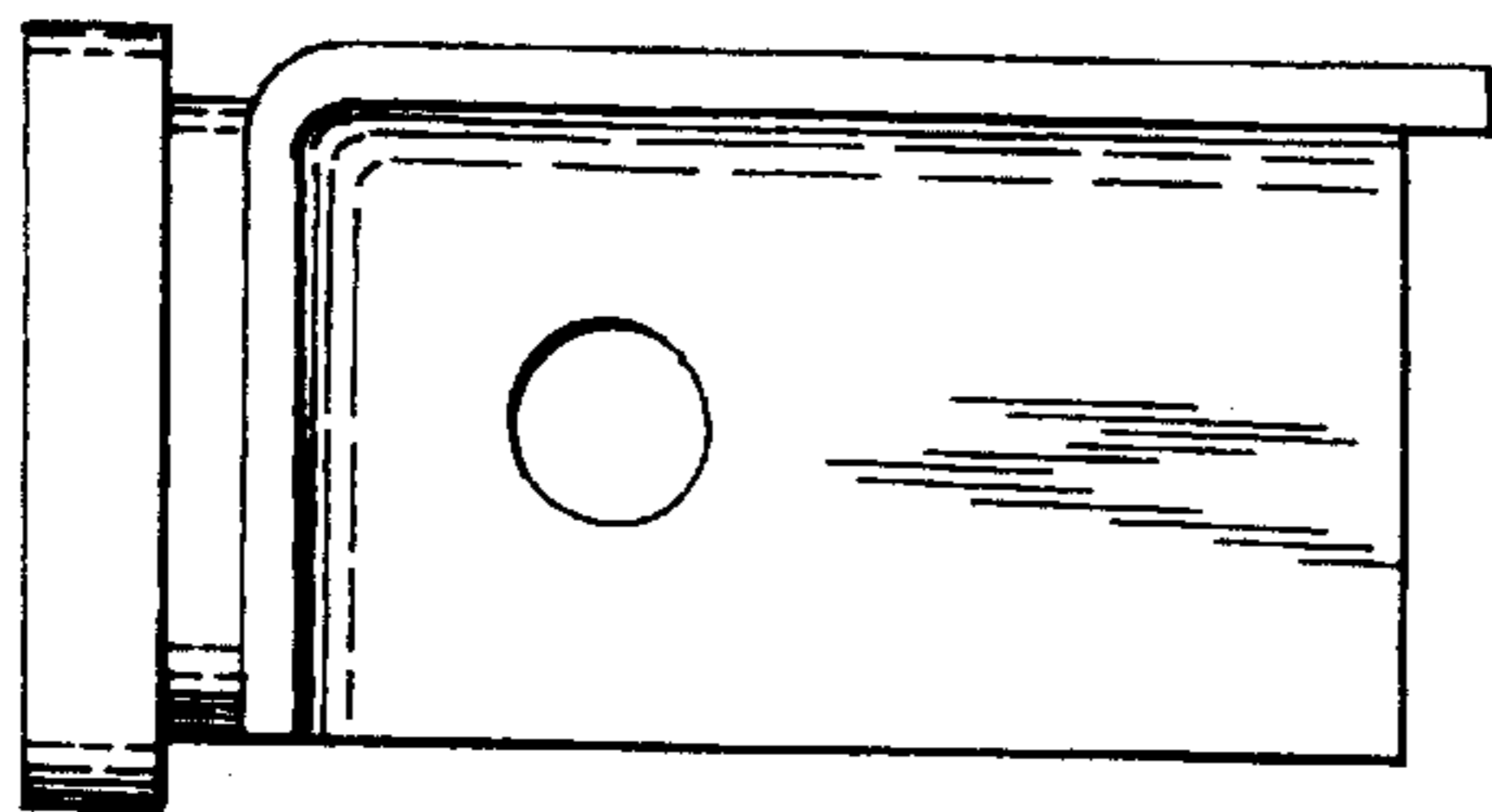

Fig. 6

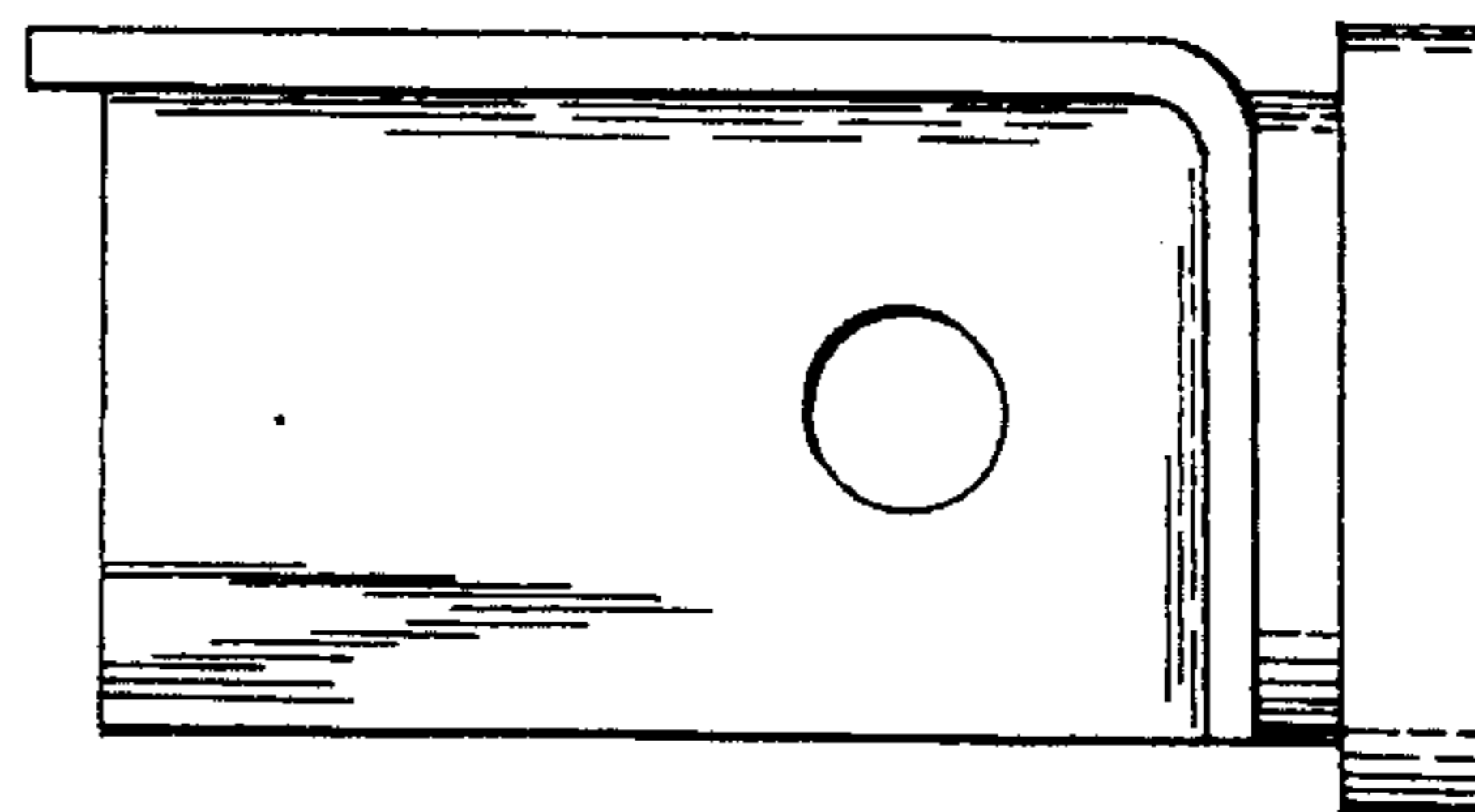

Fig. 7