



US00D372857S

# United States Patent [19] Hirai

[11] Patent Number: **Des. 372,857**

[45] Date of Patent: **\*\*Aug. 20, 1996**

## [54] BOLT AND NUT ASSEMBLY

[75] Inventor: **Masanori Hirai**, Inbagun, Japan

[73] Assignee: **Huck International, Inc.**, Irvine, Calif.

[\*\*] Term: **14 Years**

[21] Appl. No.: **29,595**

[22] Filed: **Oct. 11, 1994**

[52] U.S. Cl. .... **D8/387**

[58] Field of Search ..... D8/387, 397; 411/166,  
411/411, 402, 368, 915, 329, 426, 427,  
937.1

## [56] References Cited

### U.S. PATENT DOCUMENTS

D. 244,908	7/1977	Hatter et al. ....	D8/397
918,527	4/1909	Galey .....	411/329
949,624	2/1910	Davidson et al. ....	411/329
1,226,143	5/1917	Stubblefield et al. ....	411/329
1,971,200	8/1934	Proctor et al. .	
1,988,925	1/1935	Thomson .	
2,024,054	12/1935	Money .....	411/329
3,028,671	4/1962	Berger .....	D8/387 X
3,304,109	2/1967	Schuster .	
3,339,003	8/1967	Cessna .	
3,702,628	11/1972	Cosenza .....	411/937.1 X
3,821,871	7/1974	Schmitt .	
4,326,825	4/1982	Volkman et al. .	
4,472,095	9/1984	Molina .....	411/427 X
4,957,401	9/1990	Hatter .	
5,039,265	8/1991	Rath et al. .	
5,088,868	2/1992	Cosenza et al. ....	411/937.1 X
5,123,793	6/1992	Bonstein .....	411/937.1 X

## FOREIGN PATENT DOCUMENTS

2238191 2/1974 Germany .

*Primary Examiner*—Paula A. Mortimer  
*Attorney, Agent, or Firm*—Harness, Dickey & Pierce, P.L.C.

## [57] CLAIM

The ornamental design for a bolt and nut assembly, as shown and described.

## DESCRIPTION

FIG. 1 is a perspective view of a bolt and nut assembly showing my new design, the bolt is shown separately for purposes of illustration;  
 FIG. 2 is a side elevational view of the bolt of FIG. 1;  
 FIG. 3 is an end elevational view of the bolt of FIGS. 1 and 2 taken in the direction of the shank of the bolt;  
 FIG. 4 is a side elevational view similar to that of FIG. 2 with the bolt rotated 90° about its axis; and  
 FIG. 5 is a top end elevational view thereof;  
 FIG. 6 is a perspective view of the nut shown separately for purposes of illustration;  
 FIG. 7 is an end elevational view thereof;  
 FIG. 8 is a side elevational view thereof, the opposite side is a mirror image;  
 FIG. 9 is a top end elevational view thereof;  
 FIG. 10 is a perspective view of a nut and bolt assembly;  
 FIG. 11 is an end elevational view thereof;  
 FIG. 12 is a side elevational view thereof, the opposite side is a mirror image thereof; and,  
 FIG. 13 is an opposite end elevational view thereof.

1 Claim, 6 Drawing Sheets

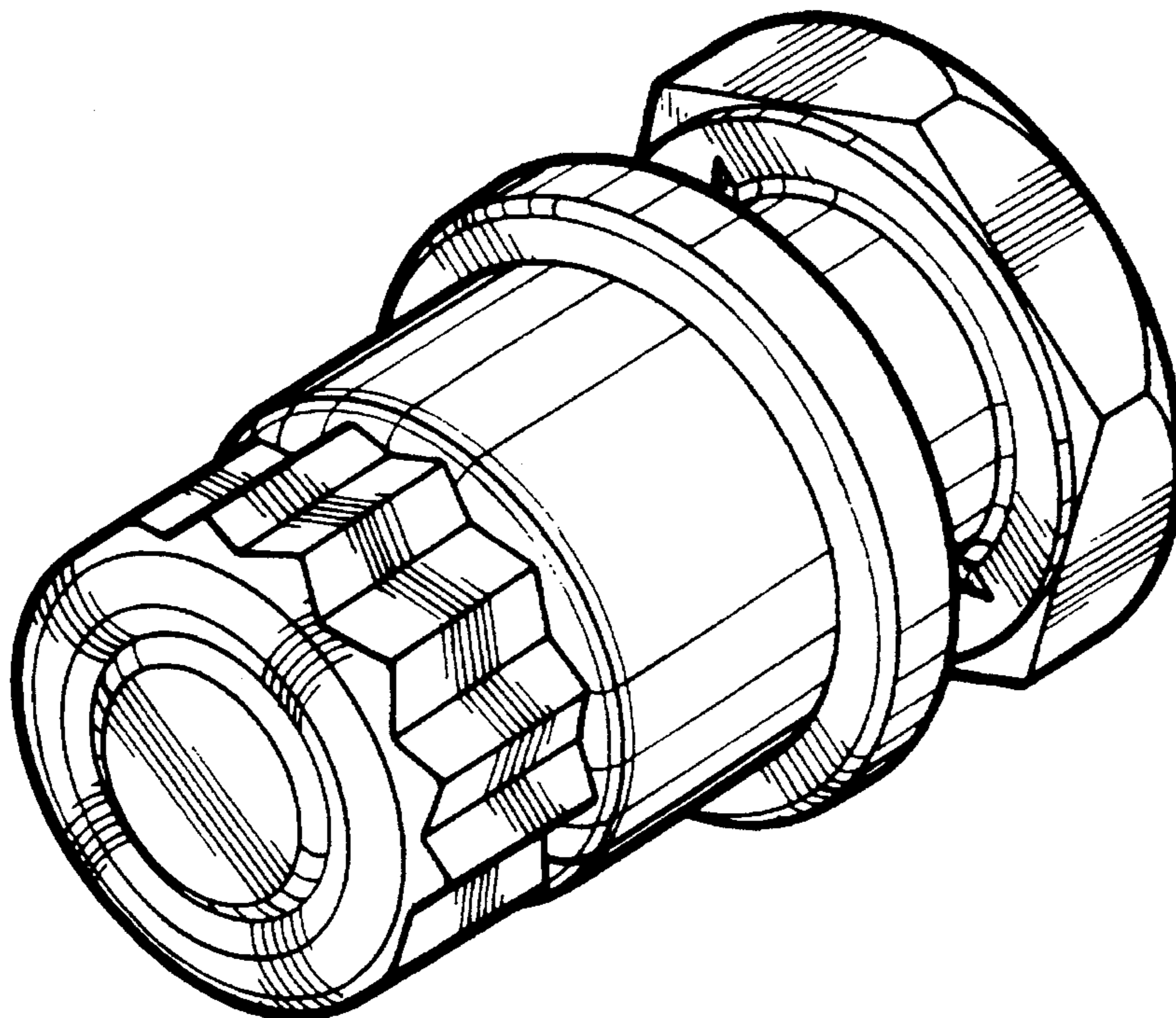

Fig-1

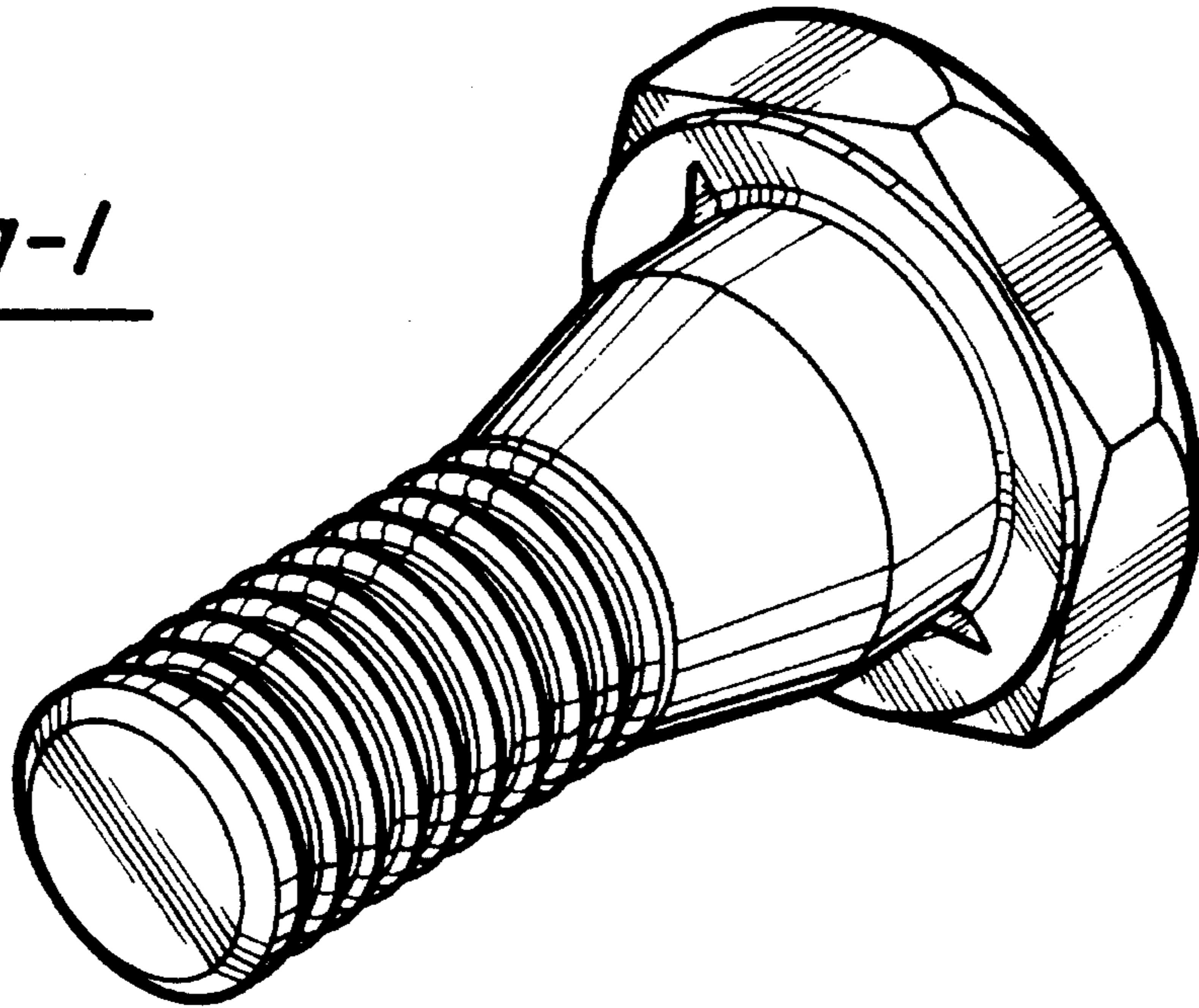
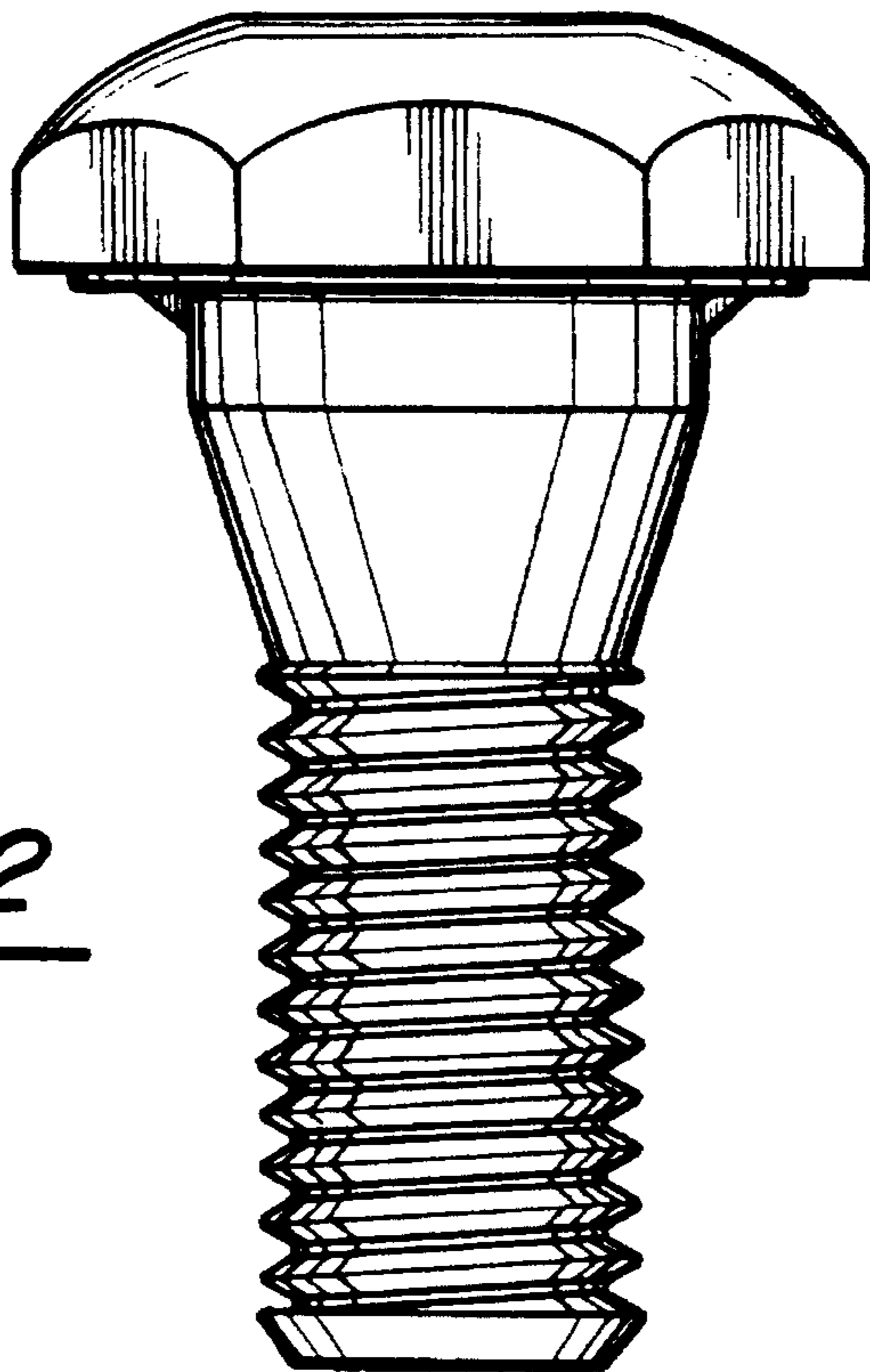

Fig-2



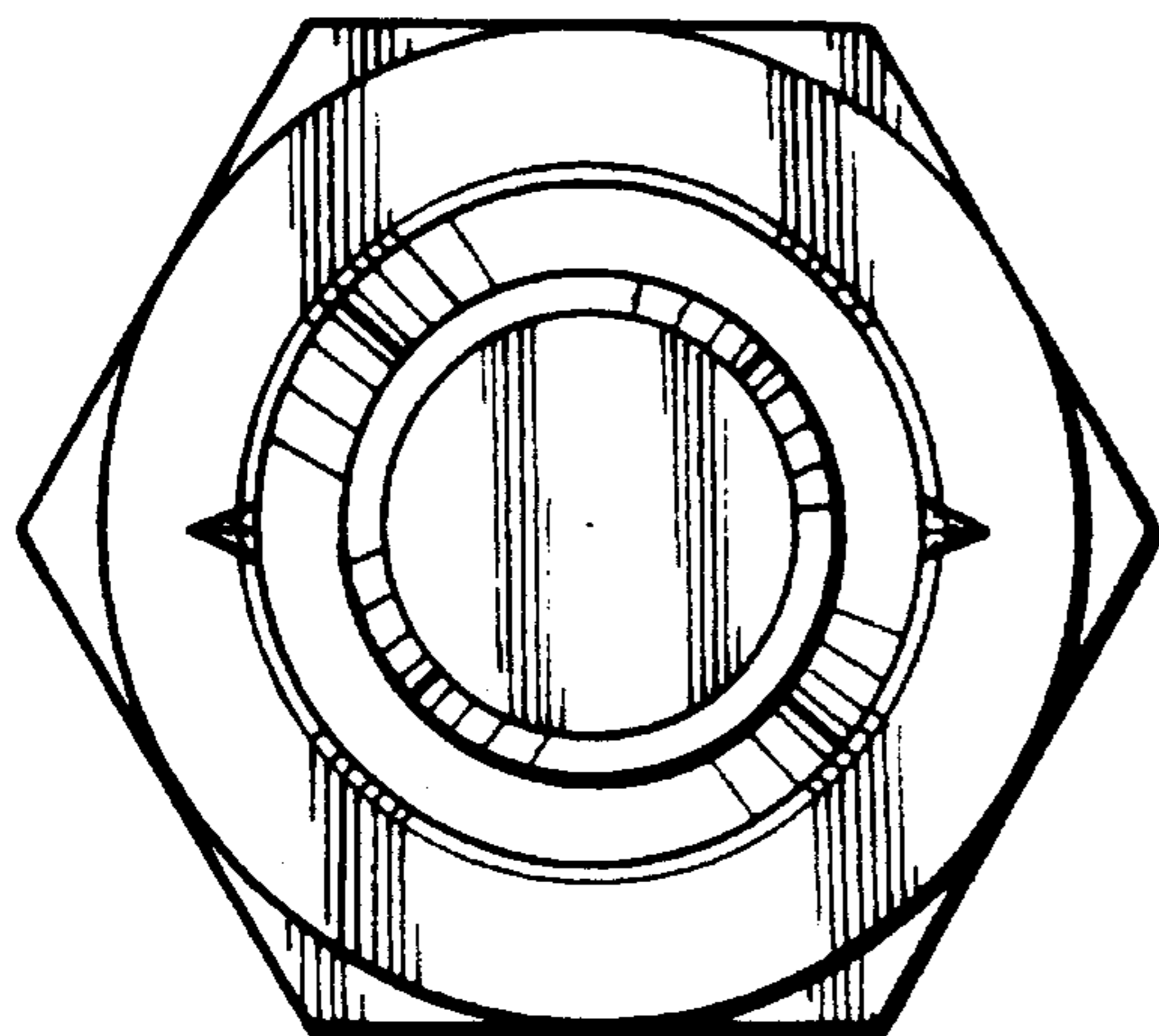

Fig-3

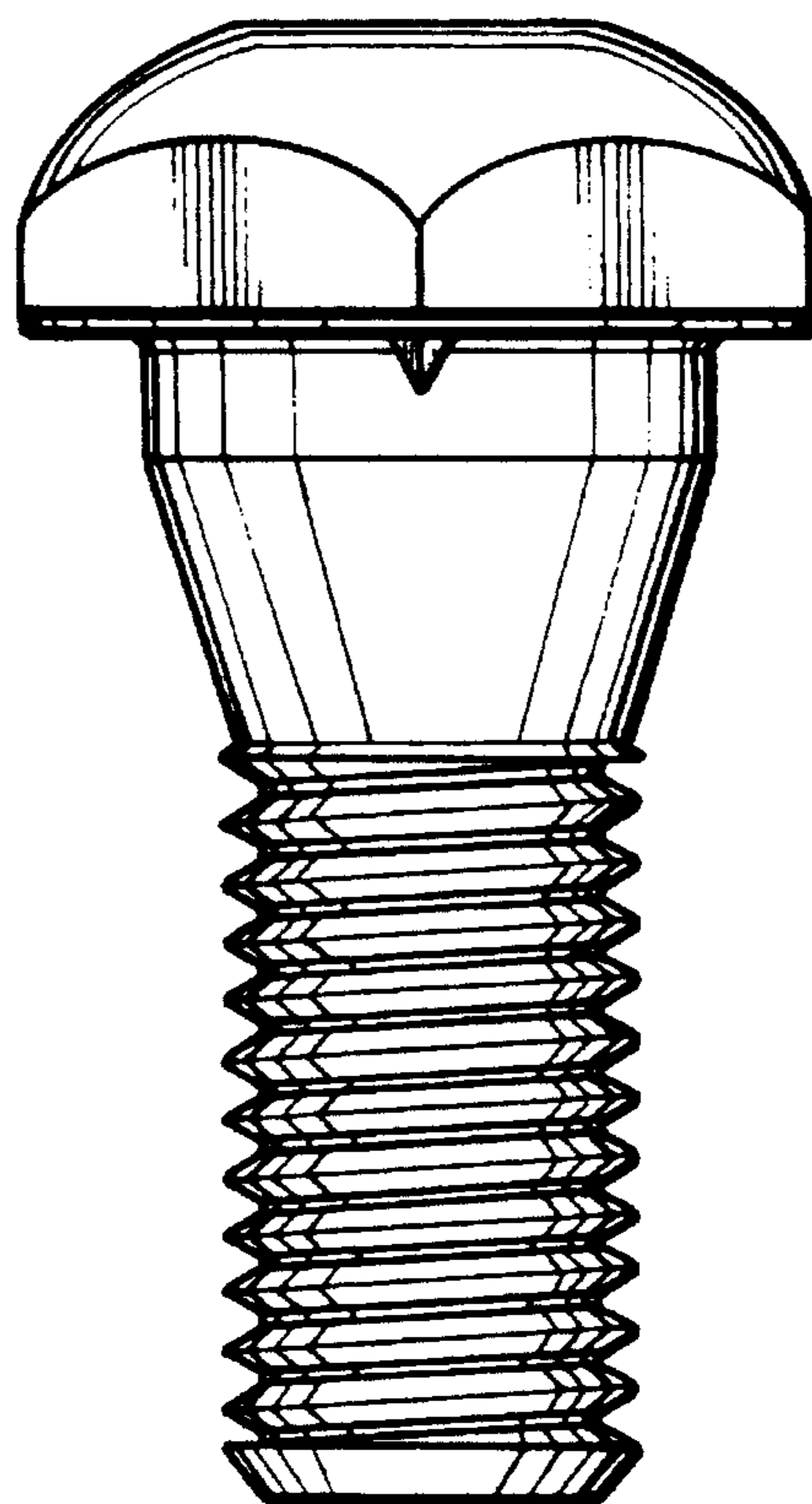

Fig-4

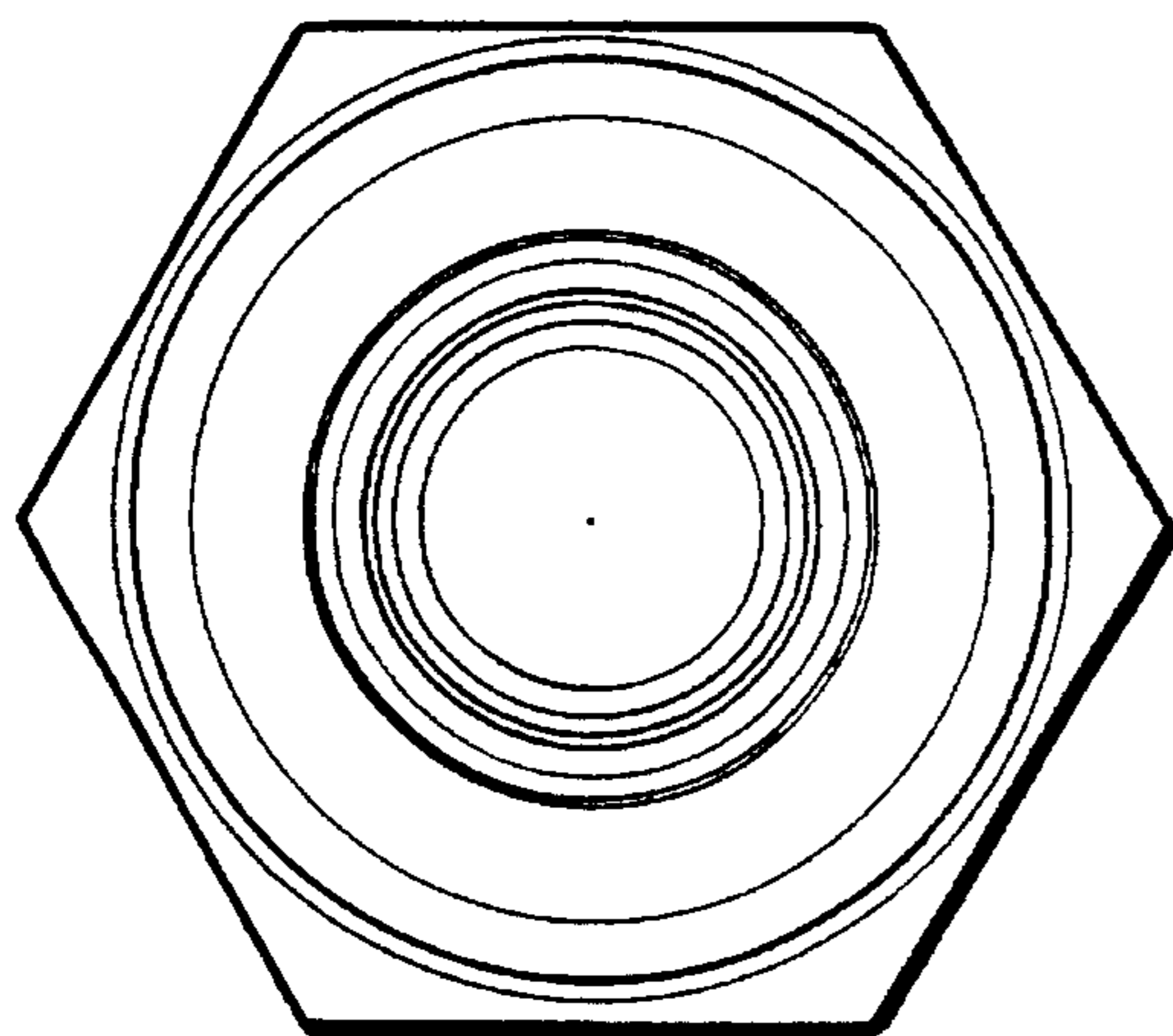

Fig-5



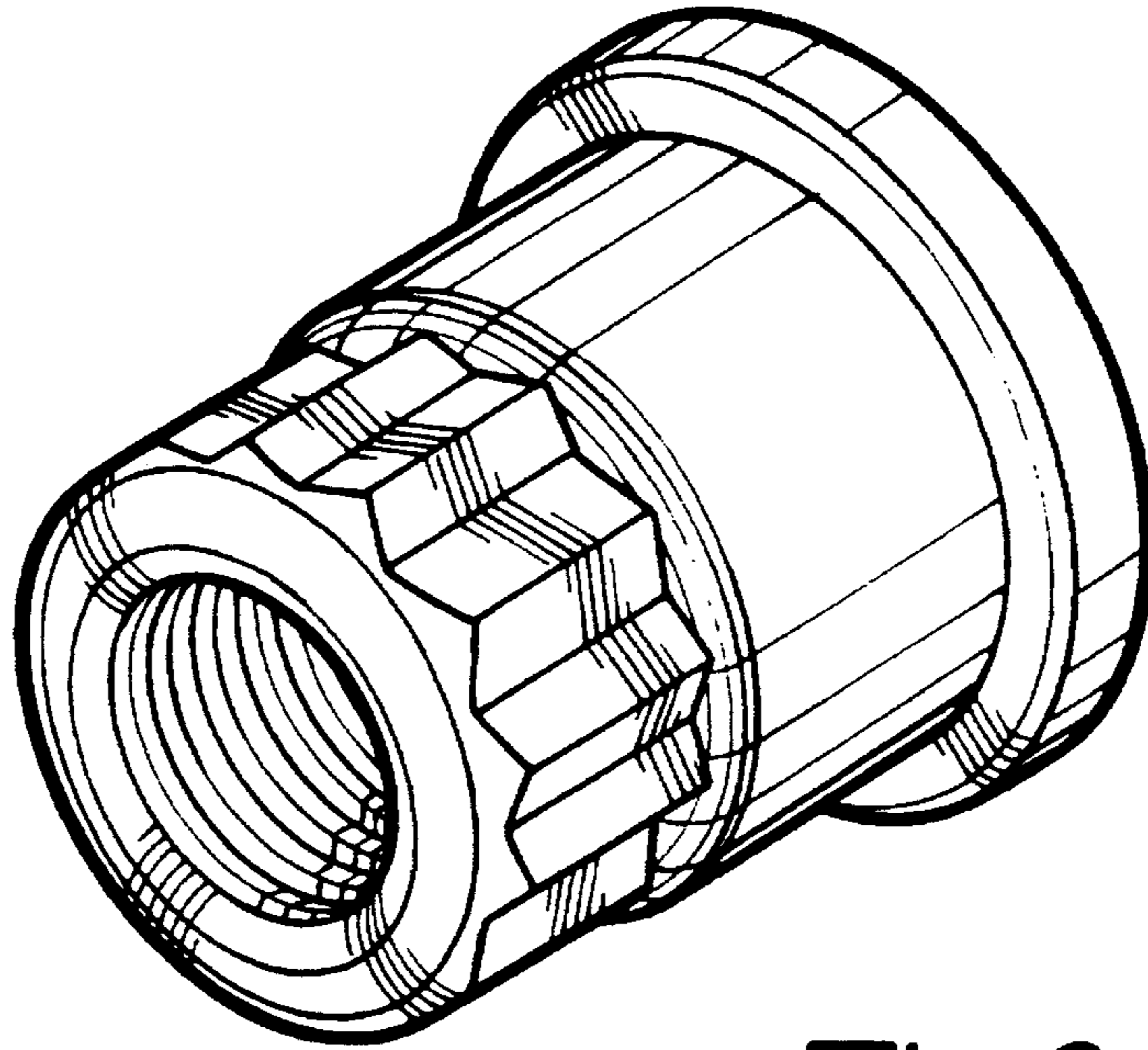

Fig-6

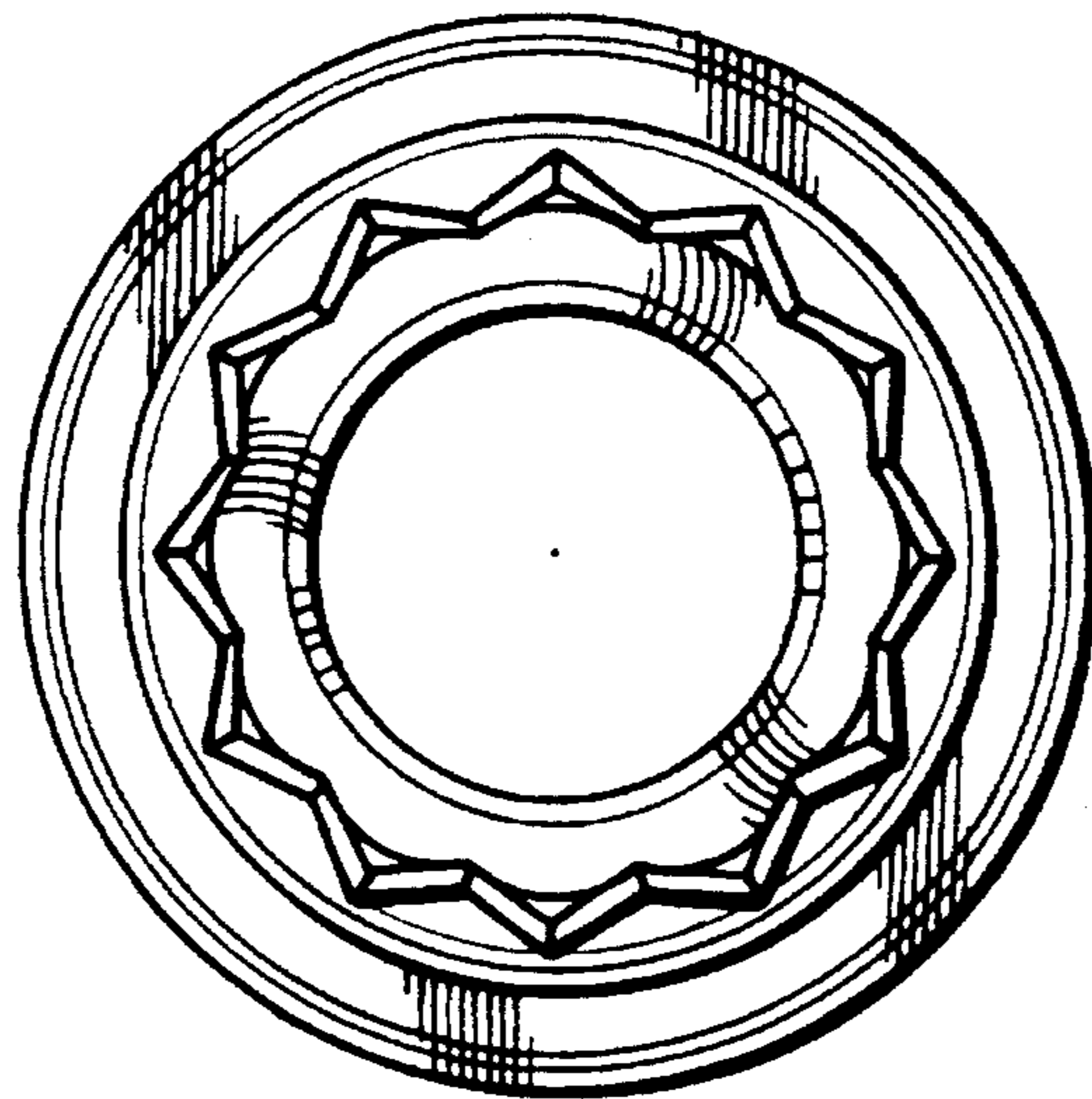

Fig-7

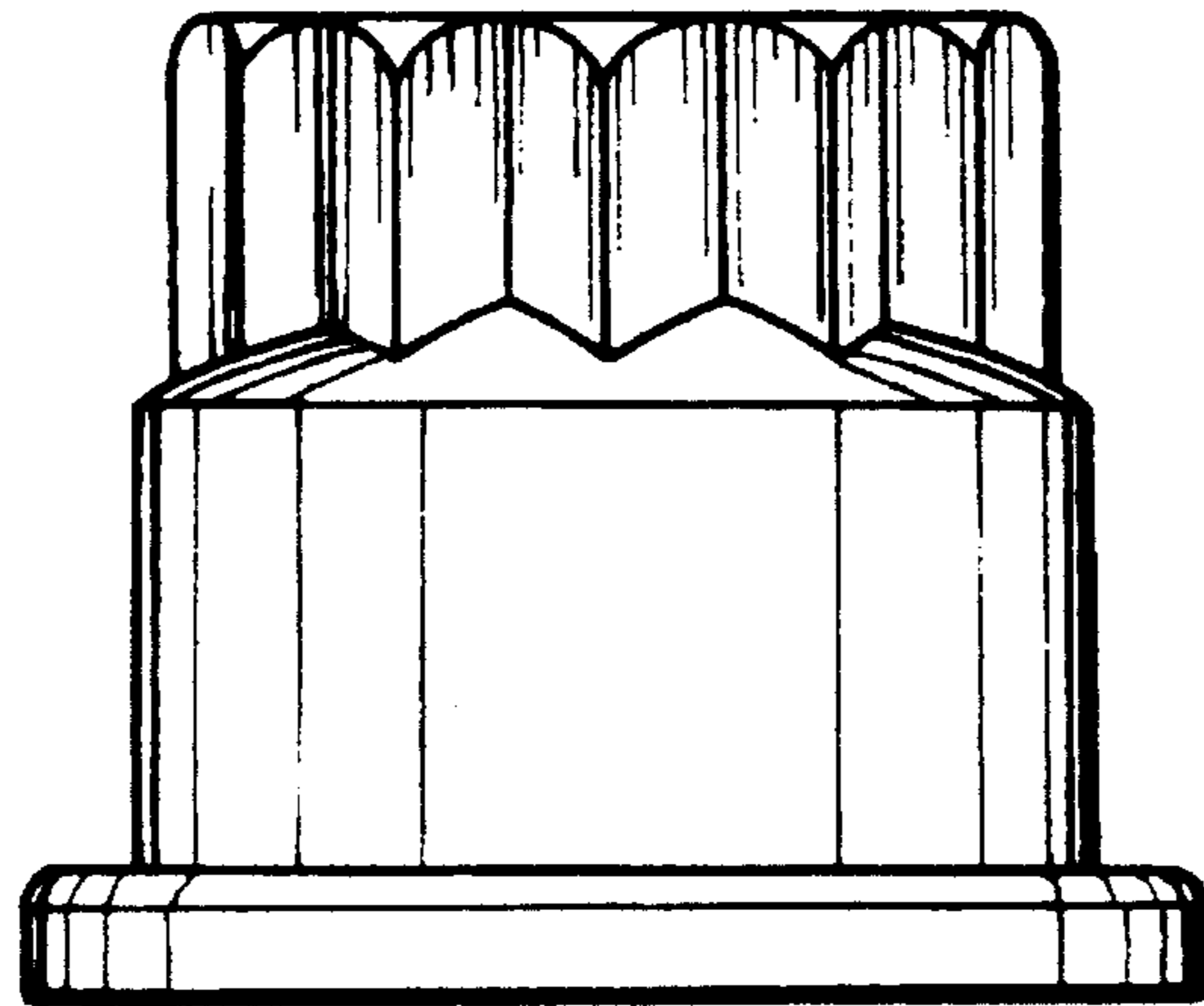

Fig-8

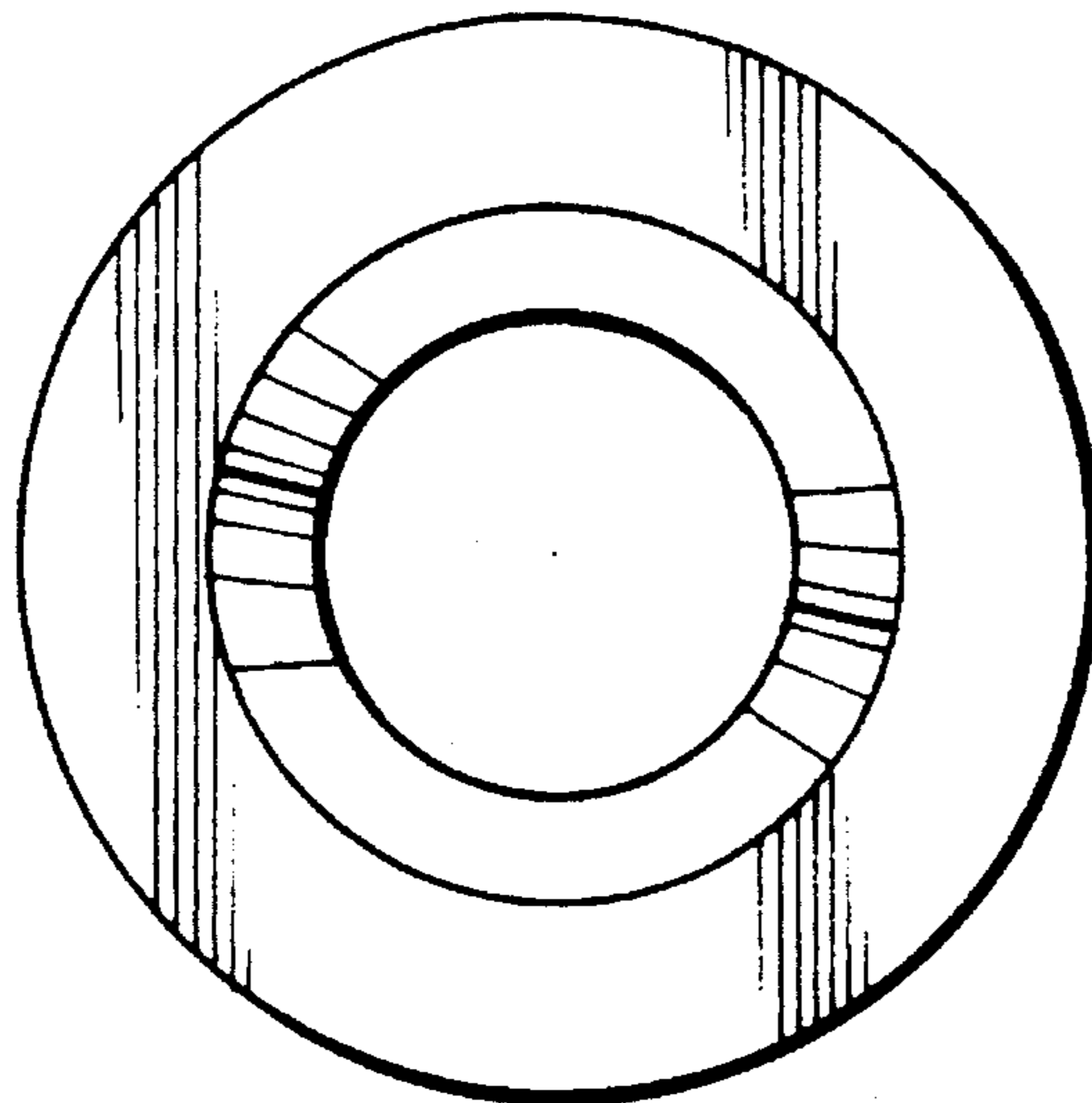

Fig-9

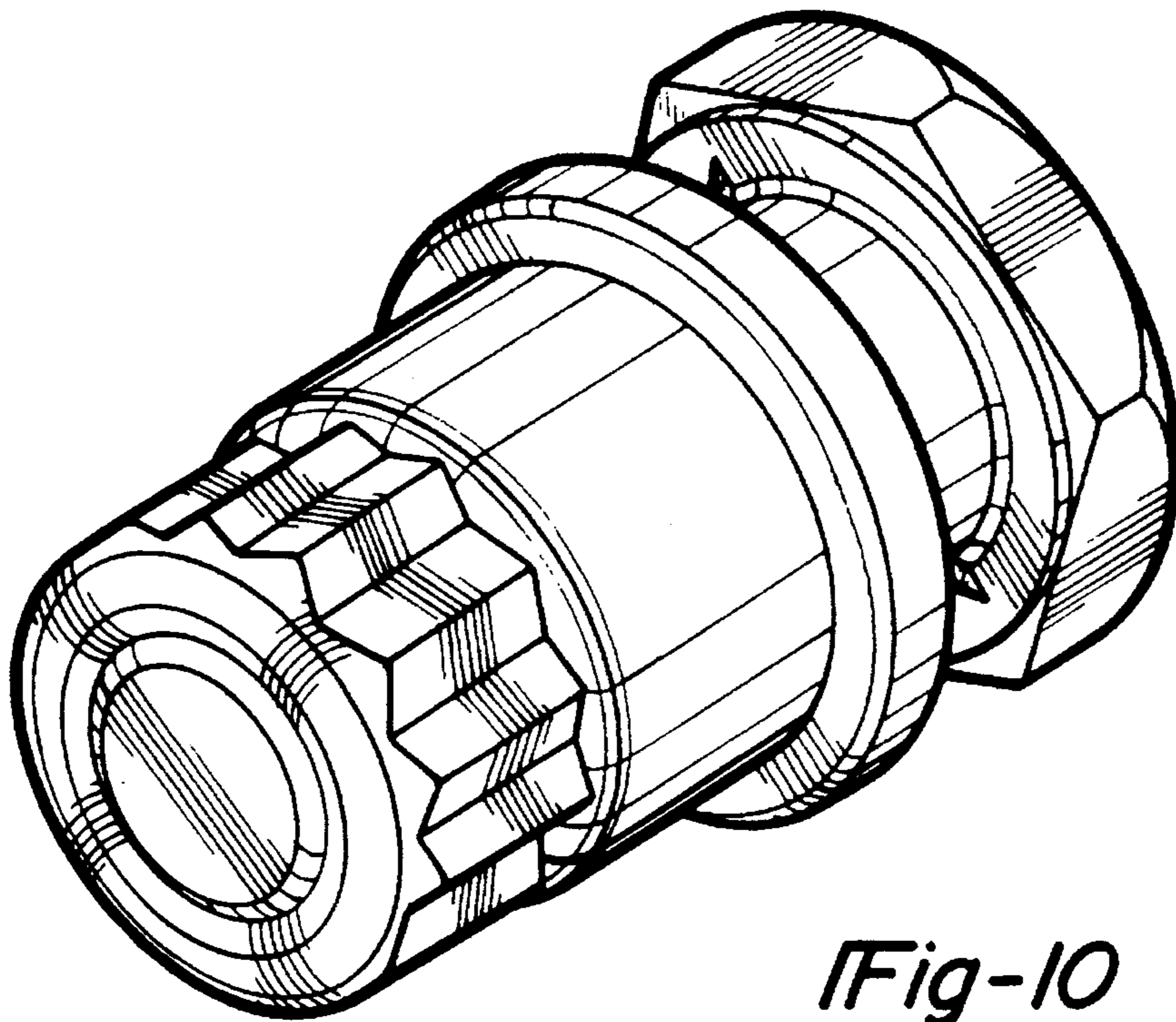

Fig-10

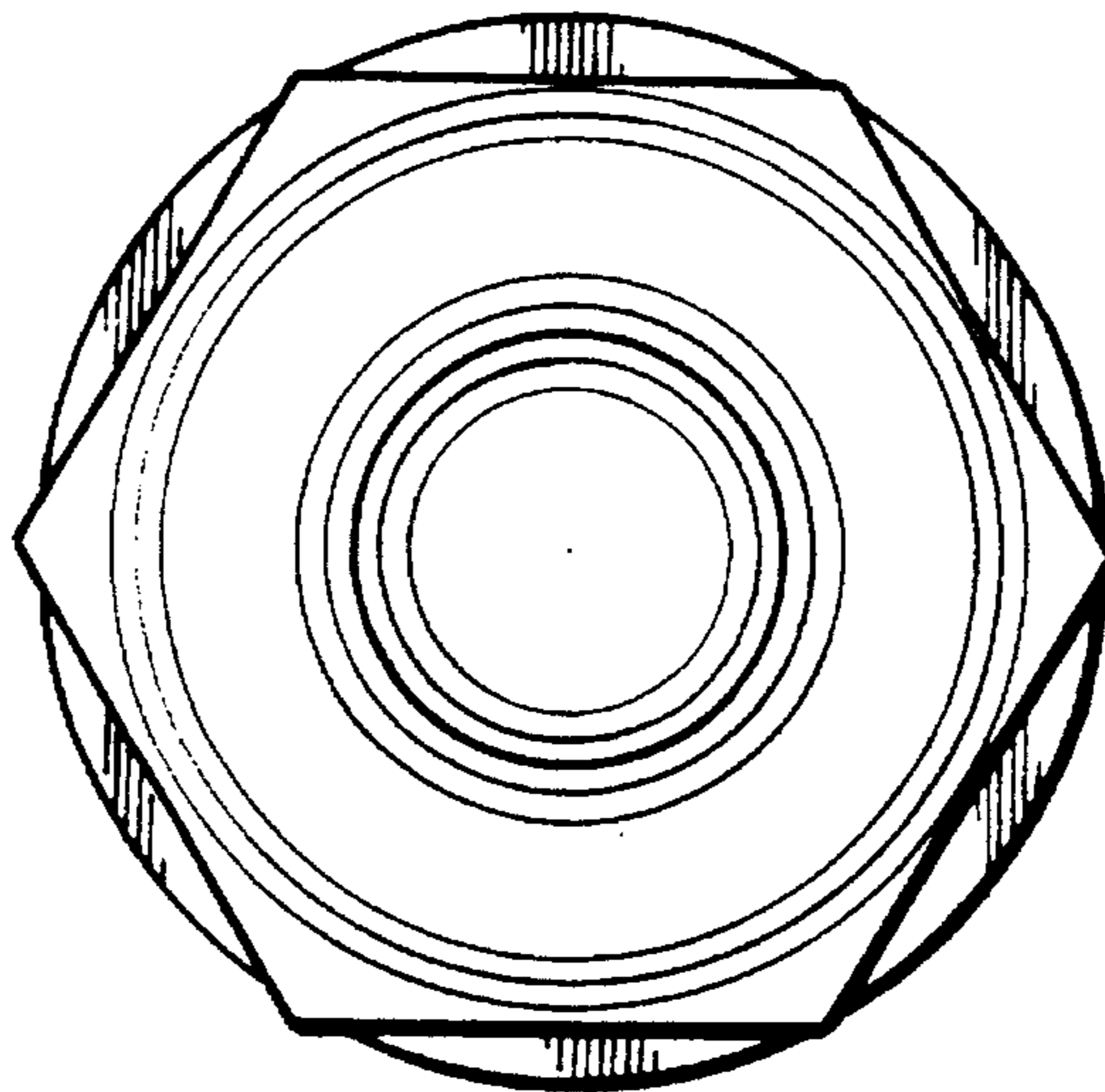

Fig-11

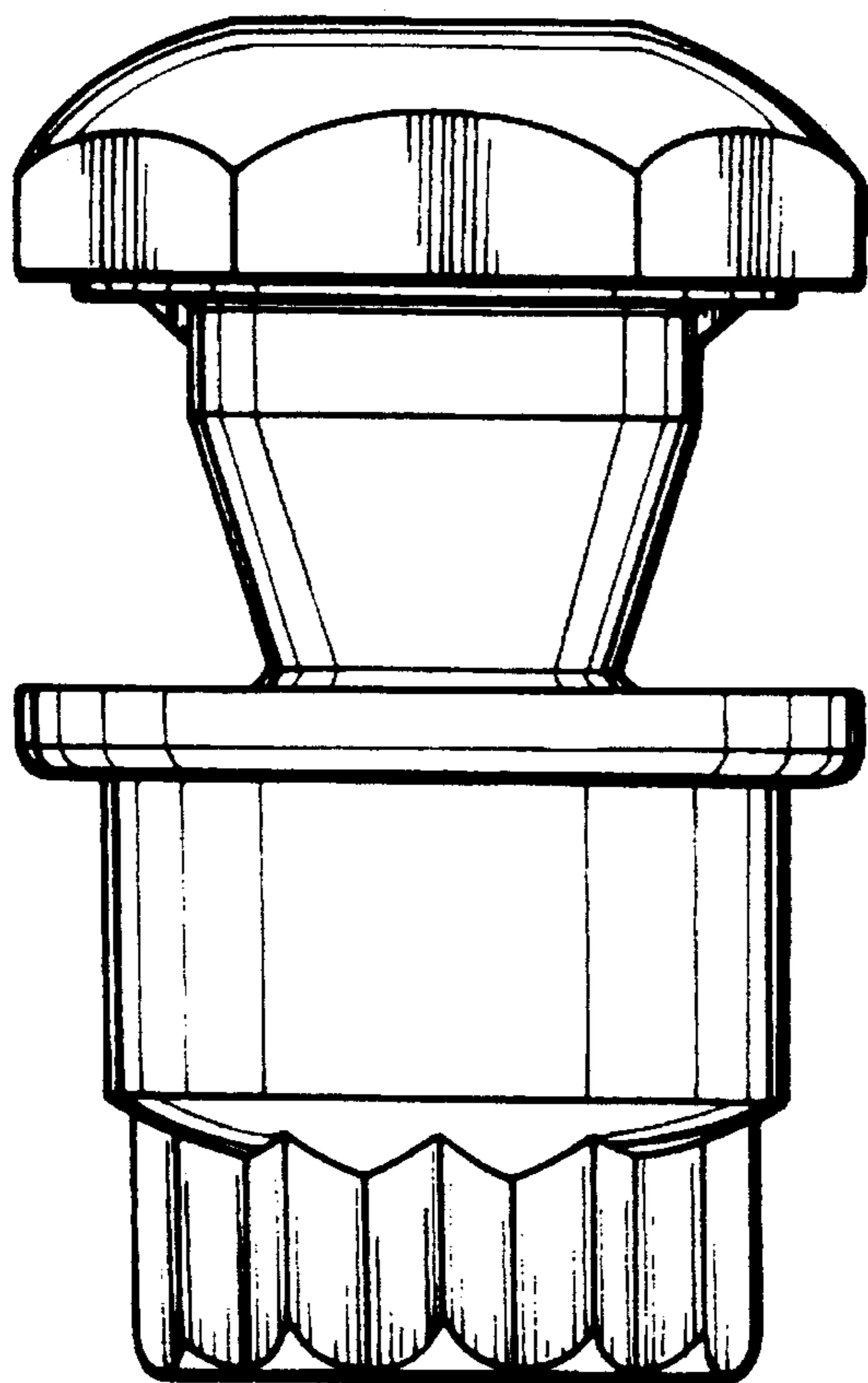

Fig-12

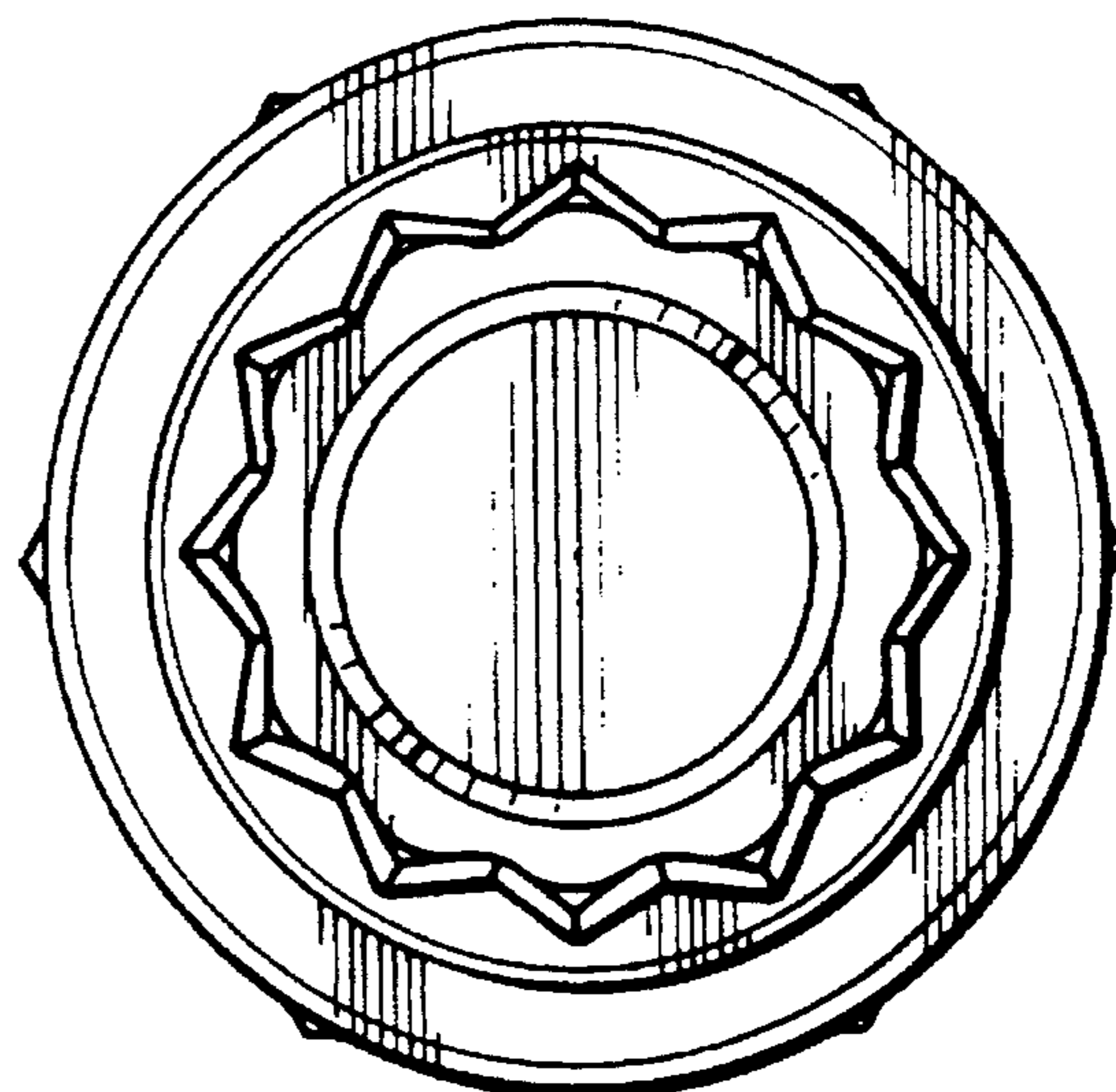

Fig-13