



US00D372818S

**United States Patent** [19]  
**Snell**

[11] **Patent Number: Des. 372,818**

[45] **Date of Patent: \*\*Aug. 20, 1996**

[54] **DESK EXTENSION**

[75] Inventor: **Rusty B. Snell**, Maryville, Tenn.

[73] Assignee: **Rubbermaid Office Products Inc.**,  
Maryville, Tenn.

[\*\*] Term: **14 Years**

[21] Appl. No.: **39,848**

[22] Filed: **Jun. 6, 1995**

[52] U.S. Cl. .... **D6/483**; D6/482; D6/486

[58] Field of Search ..... D6/480-489, 495,  
D6/429, 430, 431, 423, 511, 422, 425,  
427; 108/150, 153, 156, 161

[56] **References Cited**

**U.S. PATENT DOCUMENTS**

D. 277,249 1/1985 Dunbar ..... D6/483  
D. 336,185 6/1993 Deinen et al. .... D6/486

**OTHER PUBLICATIONS**

Domus, Dec. 1990, Schede Uffici p. 24, table at bottom.  
Ethospace Interiors by Herman Miller, p. 10, table in center.  
Domus, Dec. 1990, Schede Uffici p. 58, table at bottom.  
Interiors, Sep. 1980, p. 127, table at top right.  
Catalog page, Table desk extension; Turnstone, a Steelcase  
Company, 3528 Lousma Drive S.E., Wyoming, Michigan  
49548-2251. Publication date 1993.

Pp. 110 and 112, Peninsula and conference tables, Visible, a  
Subsidiary of Wallace Computer Services Inc. 1750 Wallace  
Avenue, St. Charles, Illinois 60174. Publication date 1992.  
P. 91, Conference island, Misco, One Misco Plaza, Holmdel,  
New Jersey 07733. Publication date Apr. 1992.  
P. 80, Conference table; UARCO Business Products,  
URACO Incorporated, 121 North 9th Street, DeKalb, Illi-  
nois 60115. Publication date Spring 1992.

*Primary Examiner*—Janice E. Seeger  
*Attorney, Agent, or Firm*—Richard B. O’Planick; Lisa B.  
Riedesel

[57] **CLAIM**

The ornamental design for a desk extension, as shown and  
described.

**DESCRIPTION**

FIG. 1 is a top left front perspective view of a desk extension  
showing my new design;  
FIG. 2 is a top plan view thereof;  
FIG. 3 is a front elevational view thereof; the rear eleva-  
tional view being a mirror image;  
FIG. 4 is a right side elevational view thereof;  
FIG. 5 is a left side elevational view thereof; and,  
FIG. 6 is a bottom plan view thereof.

**1 Claim, 5 Drawing Sheets**

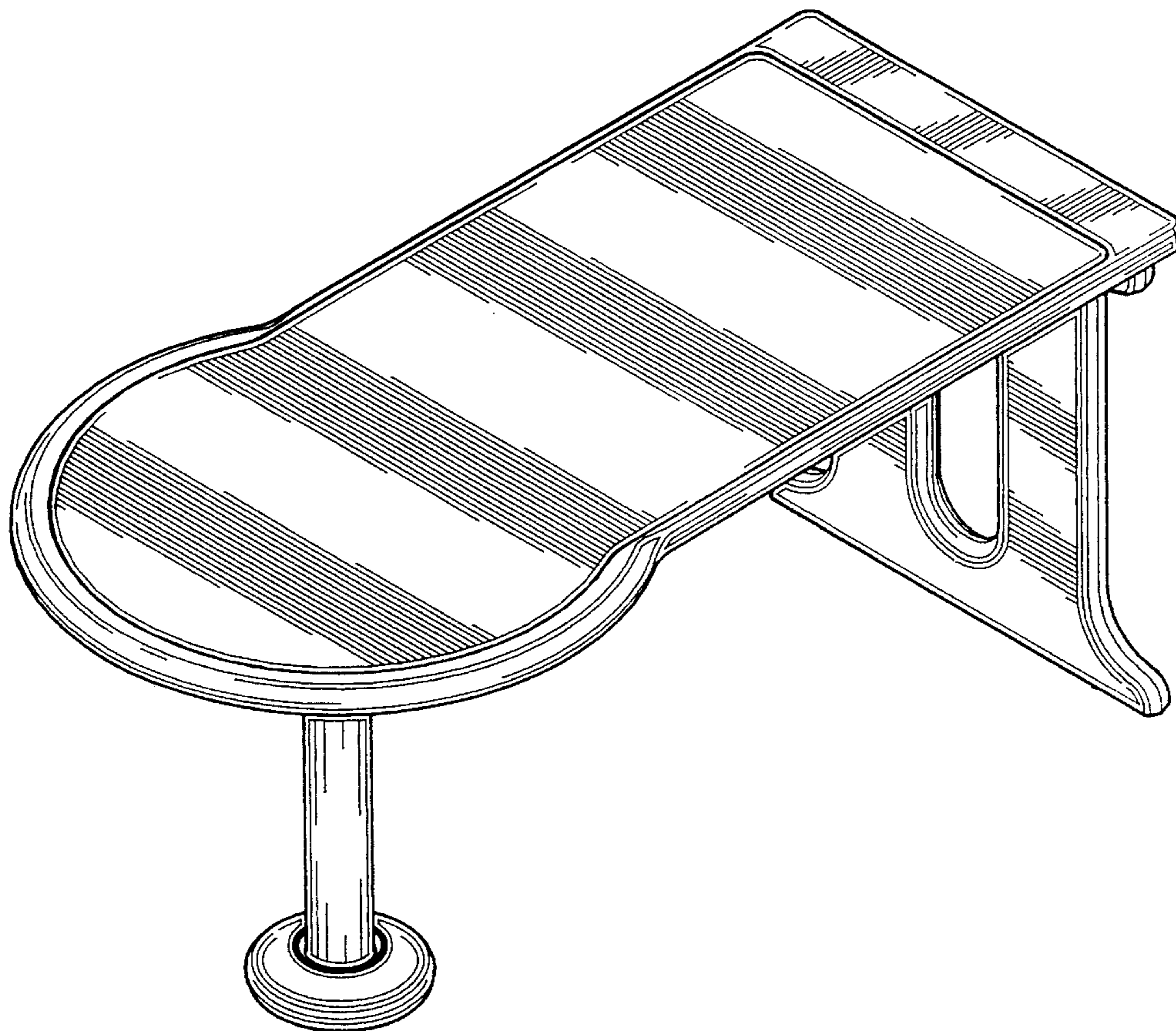

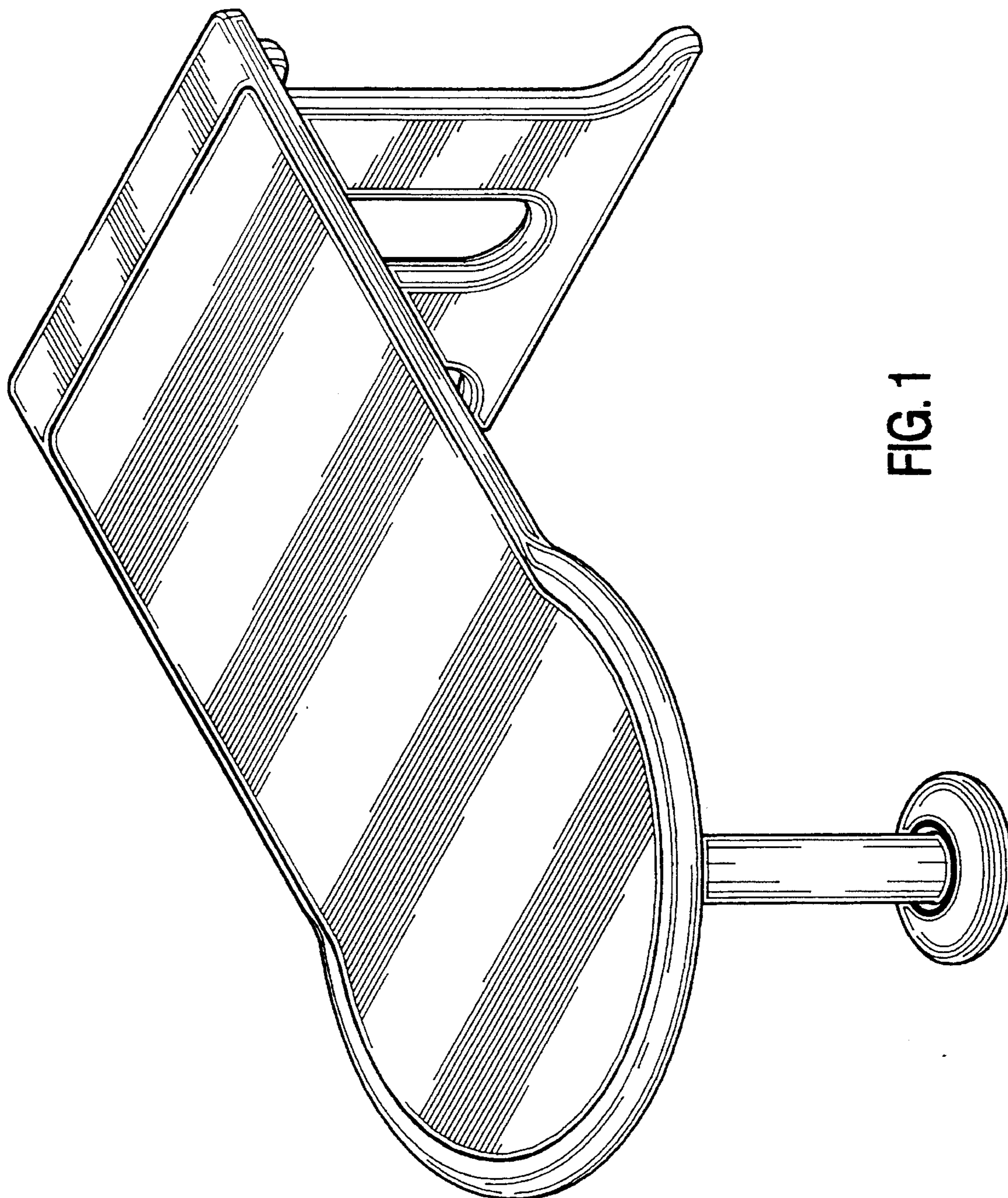

FIG. 1

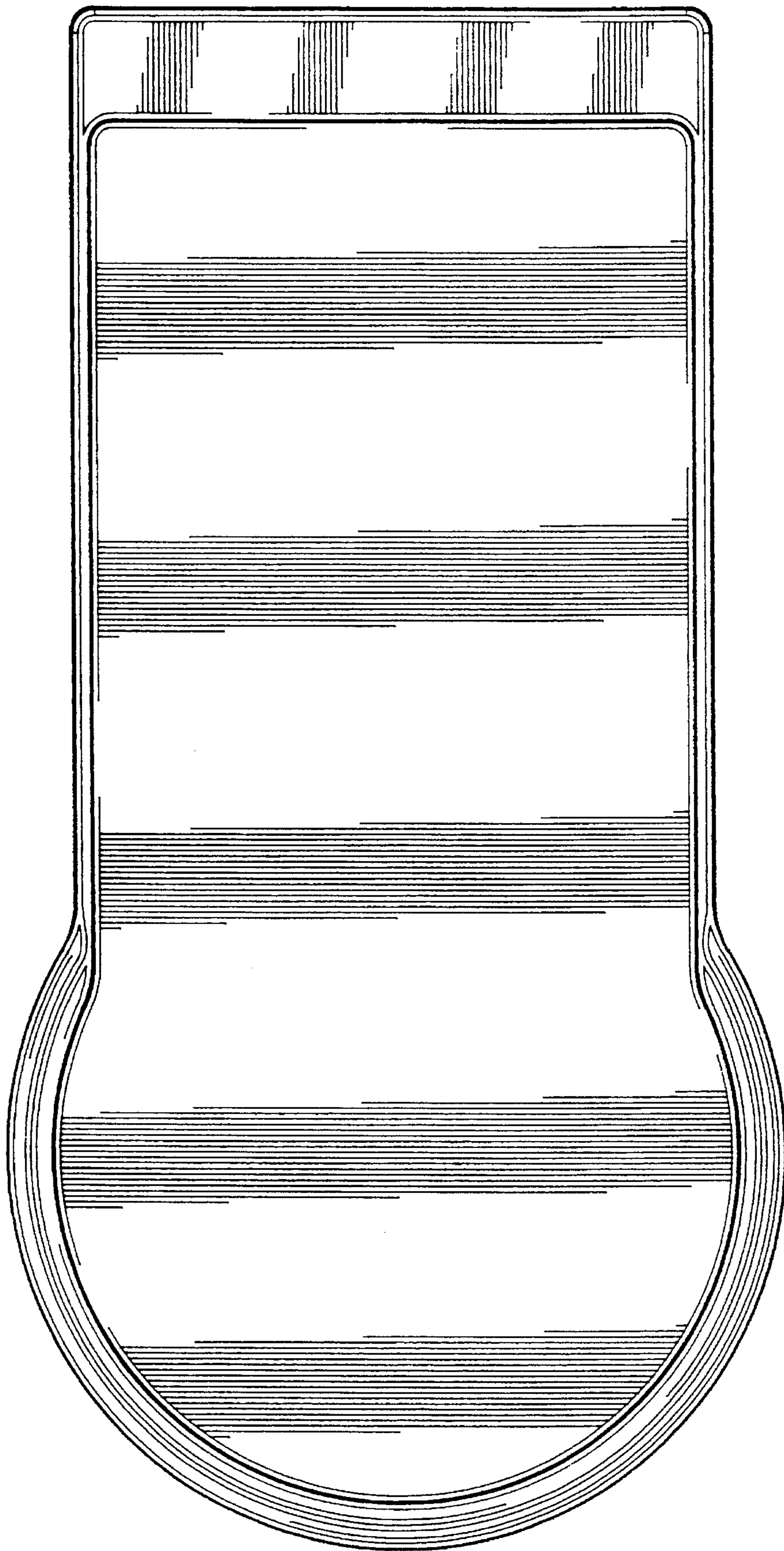

FIG. 2

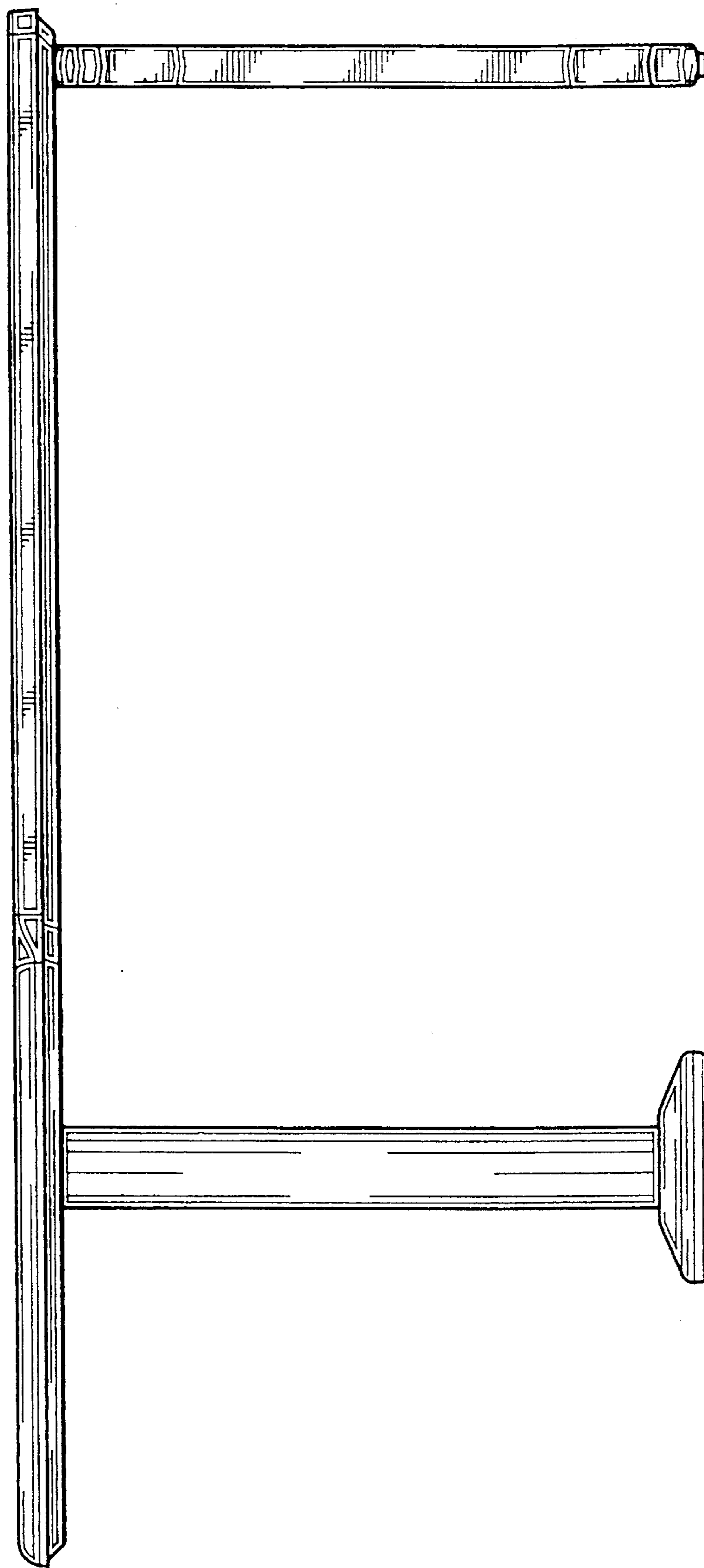

FIG. 3

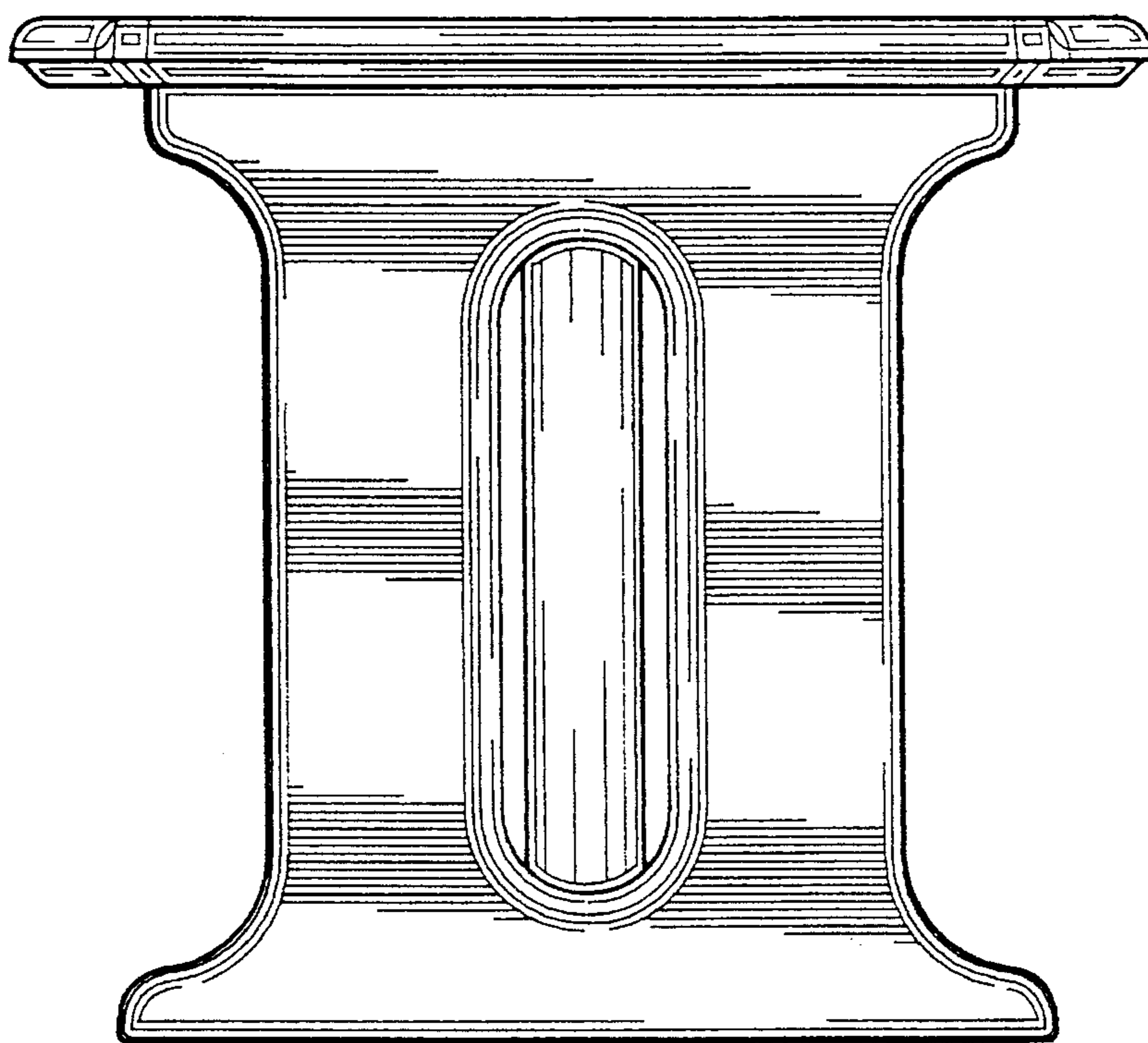

FIG. 4

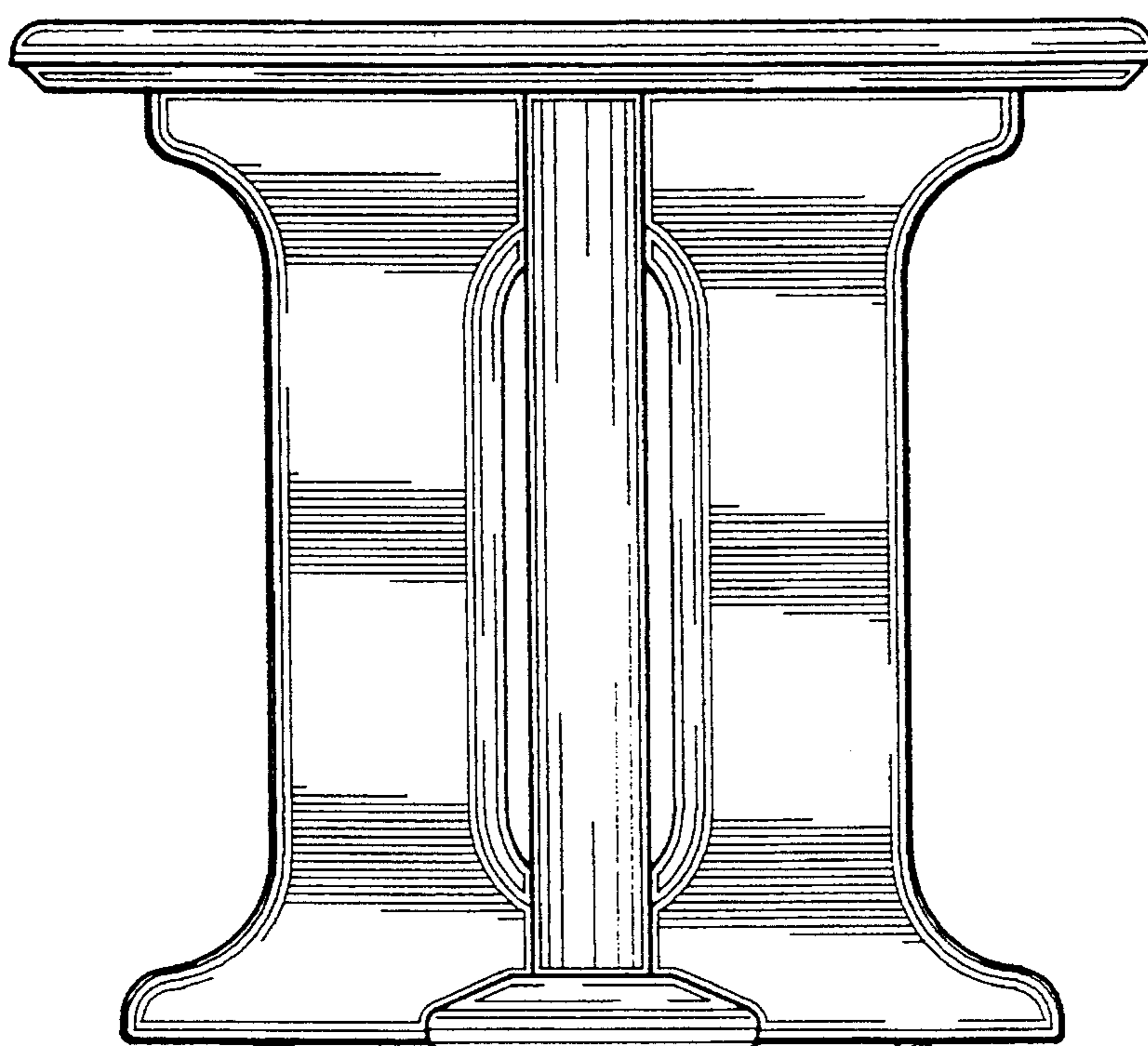

FIG. 5

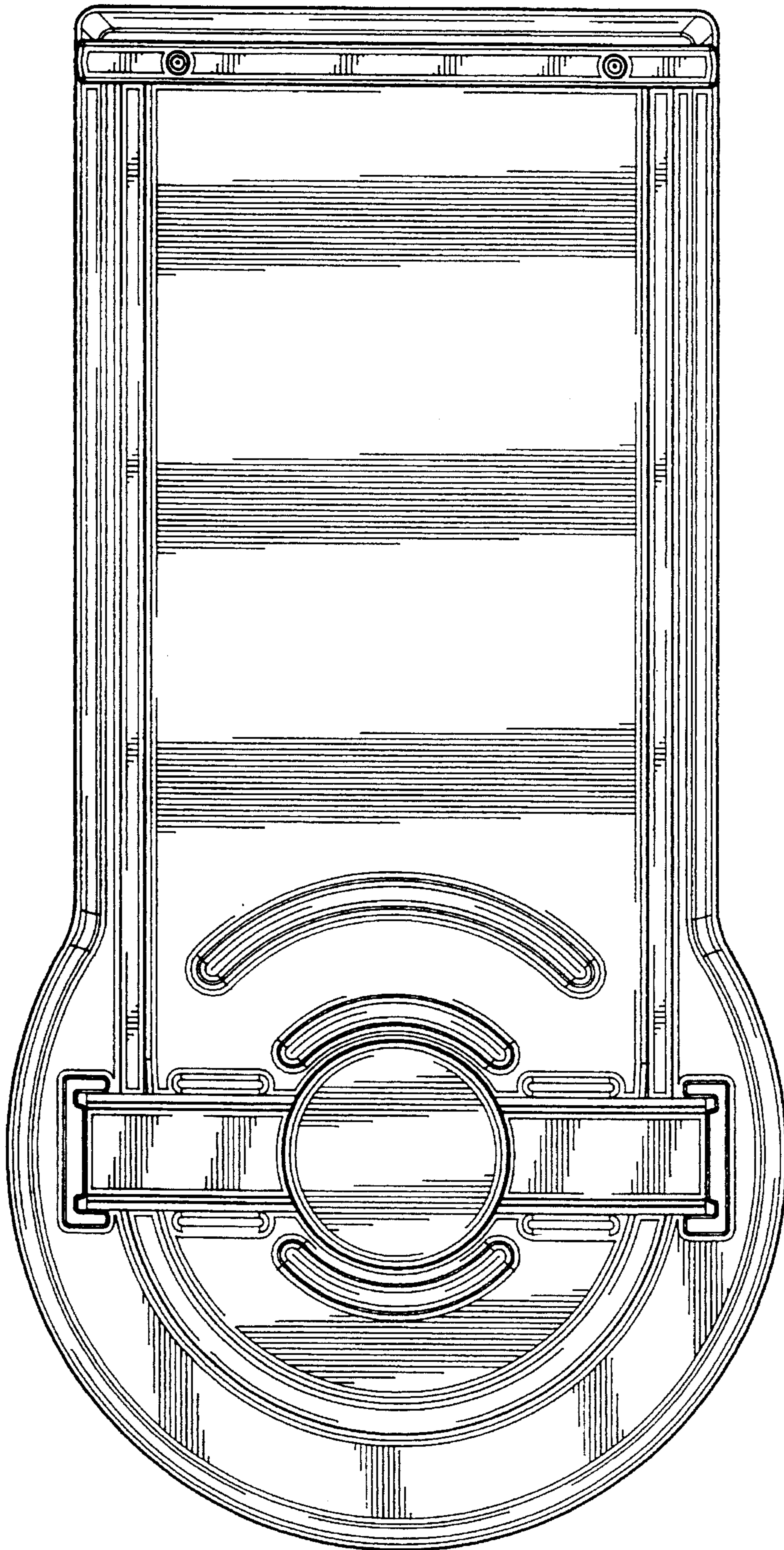

FIG. 6