



US00D372808S

United States Patent [19]

[11] Patent Number: **Des. 372,808**

Natuzzi et al.

[45] Date of Patent: ****Aug. 20, 1996**

[54] SEAT

[75] Inventors: **Pasquale Natuzzi; Raffaella Lucarelli**,
both of Santeramo In Colle, Italy

[73] Assignee: **Industrie Natuzzi, SpA**, Bari, Italy

[**] Term: **14 Years**

[21] Appl. No.: **43,737**

[22] Filed: **Sep. 11, 1995**

[52] U.S. Cl. **D6/381**; D6/334

[58] Field of Search D6/334, 335, 336,
D6/364, 371, 373, 381, 500, 501, 502;
297/232, 445.1, 446.1

[56] References Cited

U.S. PATENT DOCUMENTS

D. 366,371 1/1996 Natuzzi et al. D6/381
D. 367,371 2/1996 Natuzzi et al. D6/381

OTHER PUBLICATIONS

Natuzzi Model Orione, Oct. 1984 at International Home Furnishings Market in High Point, North Carolina.
Natuzzi Model 183, Apr. 1987 at International Home Furnishings Market in High Point, North Carolina.
Natuzzi Model 485, Apr. 1989 at International Home Furnishings Market in High Point, North Carolina.
Natuzzi Model 759, Apr. 1990 at International Home Furnishings Market in High Point, North Carolina.
Natuzzi Model 839, Apr. 1991 at International Home Furnishings Market in High Point, North Carolina.
Natuzzi Model 937, Apr. 1992 at International Home Furnishings Market in High Point, North Carolina.
Natuzzi Model 938, Oct. 1992 at International Home Furnishings Market in High Point, North Carolina.

Natuzzi Model 1145, Apr. 1994 at International Home Furnishings Market in High Point, North Carolina.

Thomasville Leather vol. 1, Feb. 1989, Sofa 2399C338 at center left.

Natuzzi Model 638/639, Apr. 1989, International Home Furnishings Market, High Point, NC.

Natuzzi Model 783, Oct. 1990, International Home Furnishings Market, High Point, NC.

Primary Examiner—Gary D. Watson

Attorney, Agent, or Firm—Bell, Seltzer, Park & Gibson, P.A.

[57] CLAIM

The ornamental design for a seat, as shown and described.

DESCRIPTION

FIG. 1 is a front perspective view of a seat showing our new design in the form of a sofa;

FIG. 2 is a front elevational view thereof;

FIG. 3 is a top plan view thereof;

FIG. 4 is a right side elevational view, the left side being a mirror image thereof;

FIG. 5 is a rear perspective view thereof;

FIG. 6 is a front elevational view of a seat showing our new design in the form of a loveseat; and,

FIG. 7 is a front elevational view of a seat showing our new design in the form of a chair.

The broken lines shown herein are for illustrative purposes only and form no part of the claimed design.

The rear views of FIGS. 6 and 7 are like FIG. 5, the difference being a matter of length.

The side view which has not been shown for FIGS. 6 and 7 is a mirror image of that shown in FIGS. 4 and 5.

1 Claim, 3 Drawing Sheets

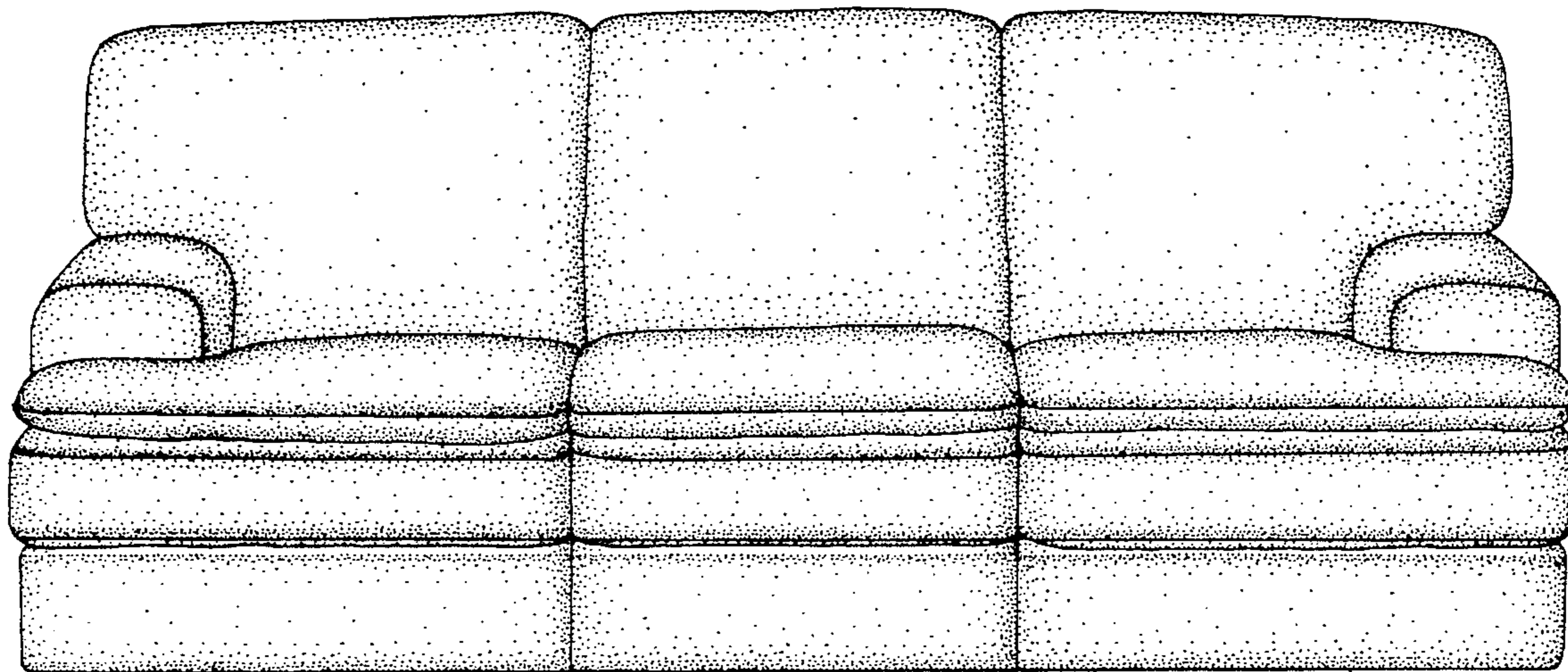

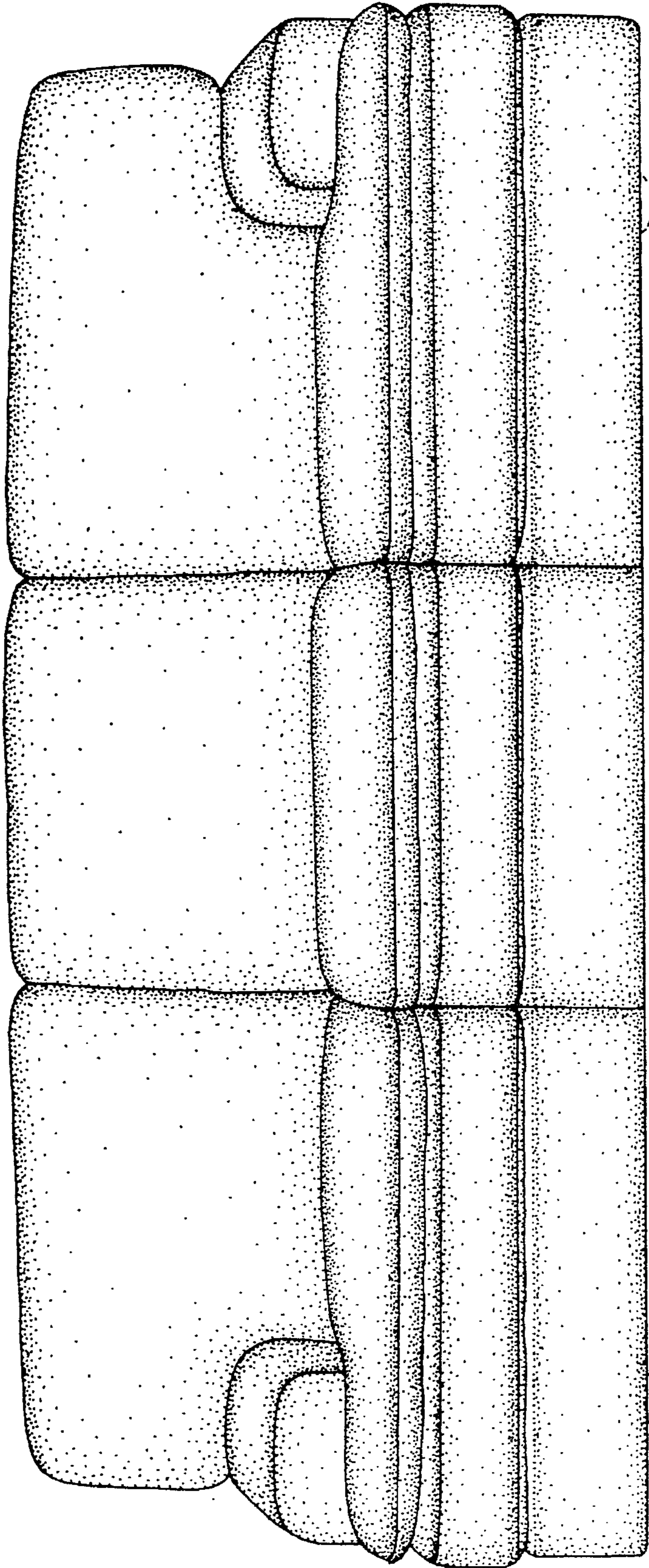

FIG. 1

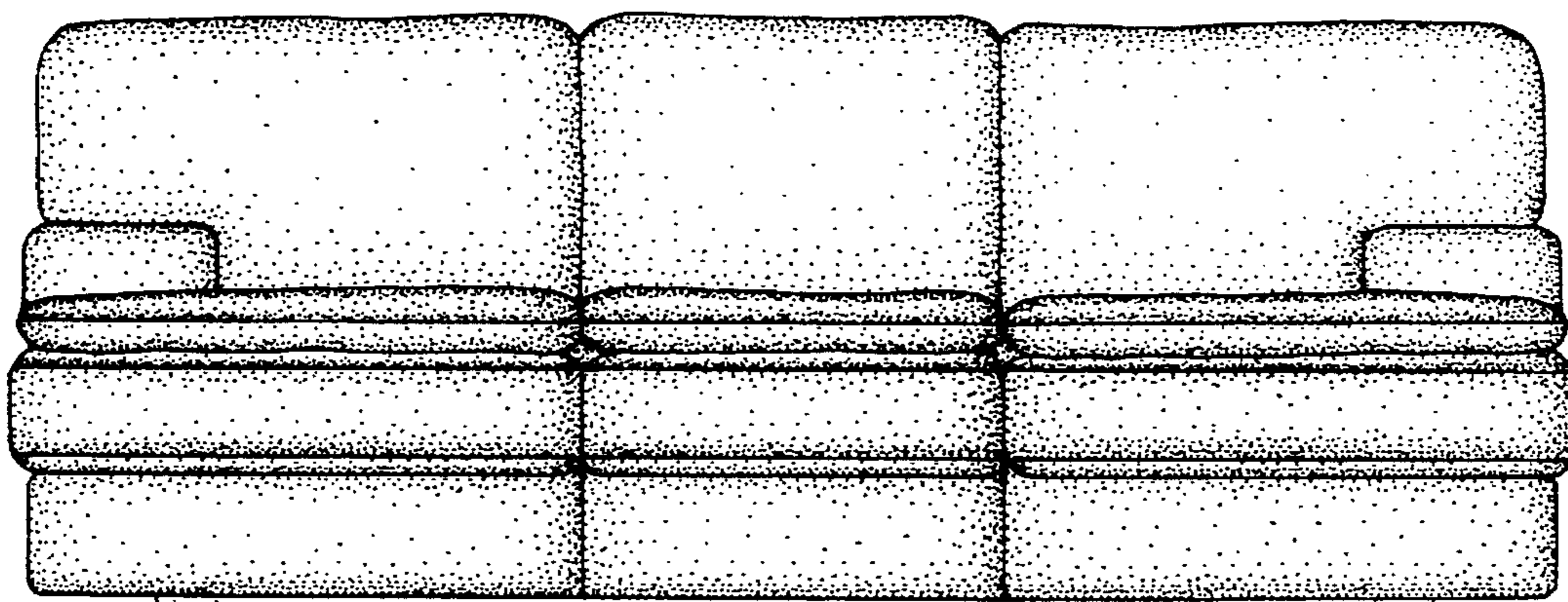

FIG- 2

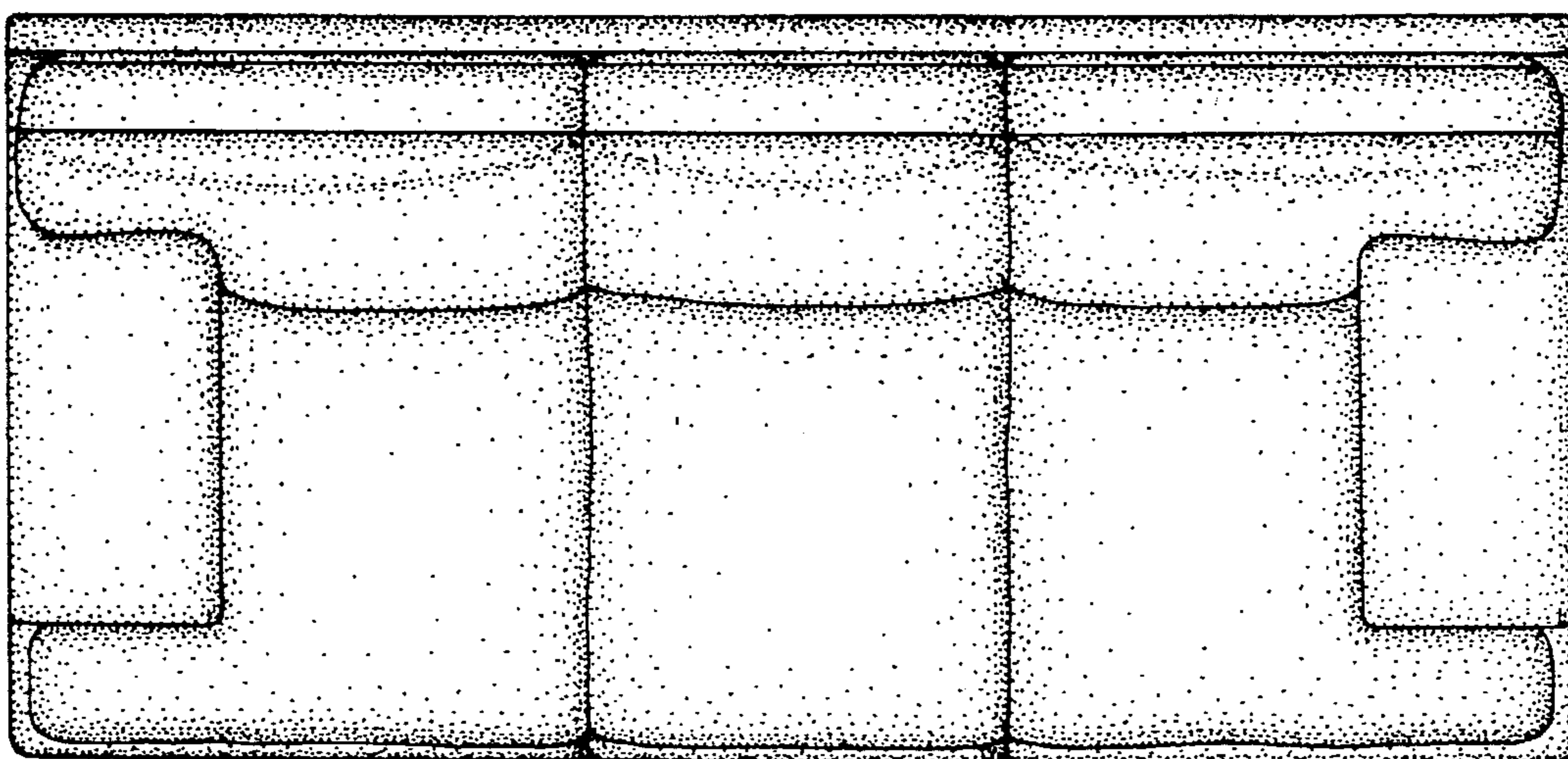

FIG- 3

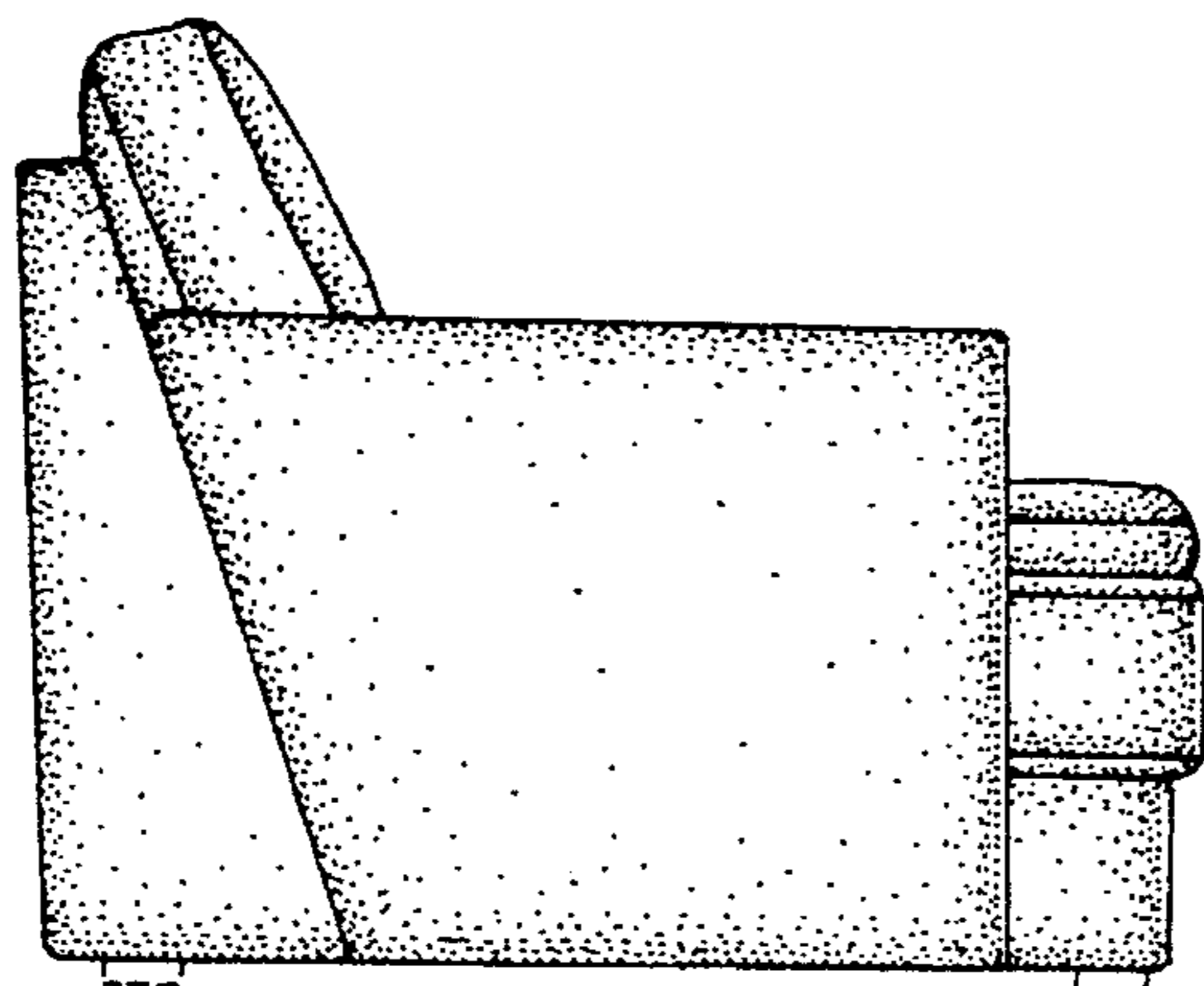

FIG- 4

FIG-5

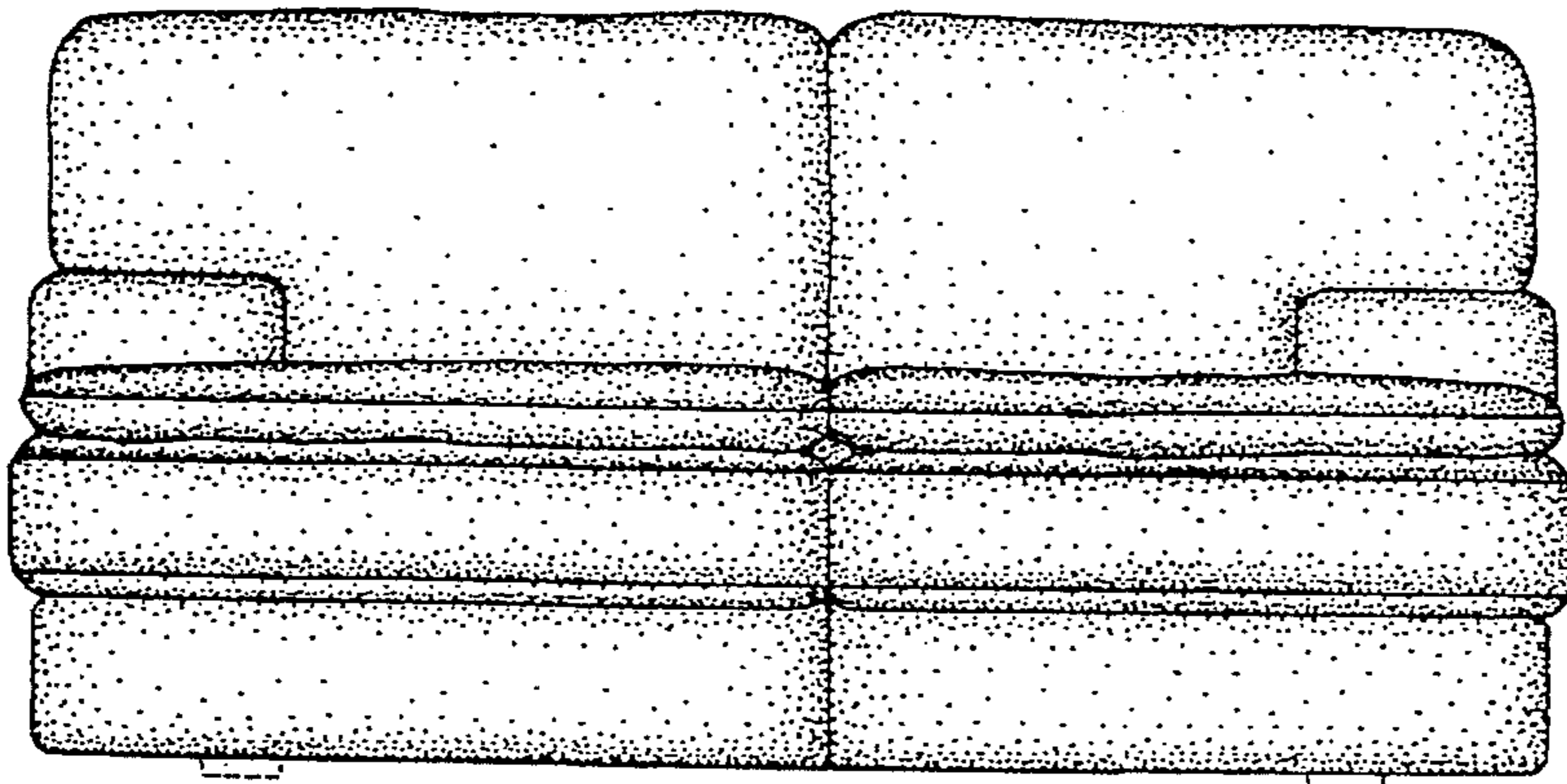
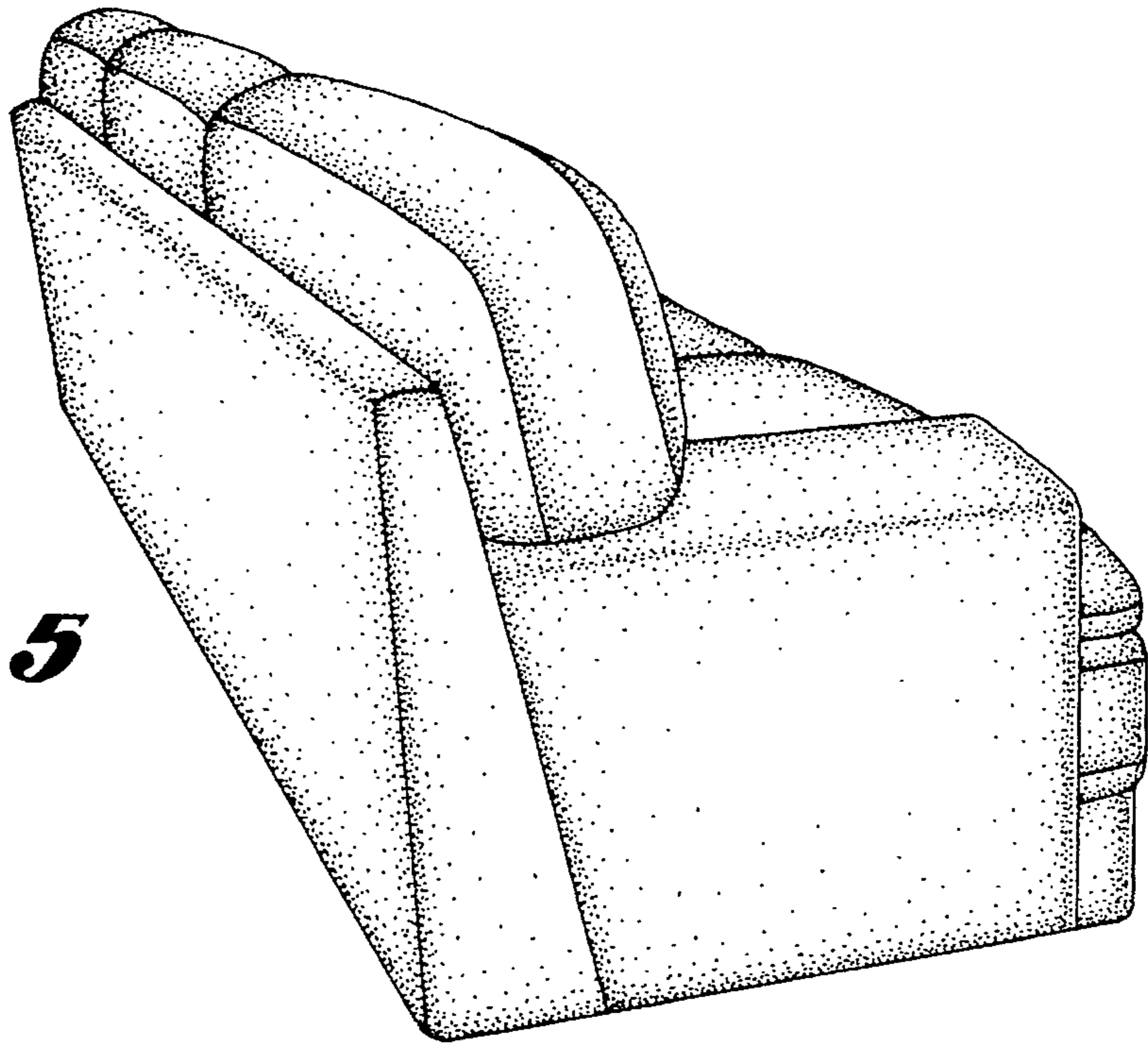

FIG-6

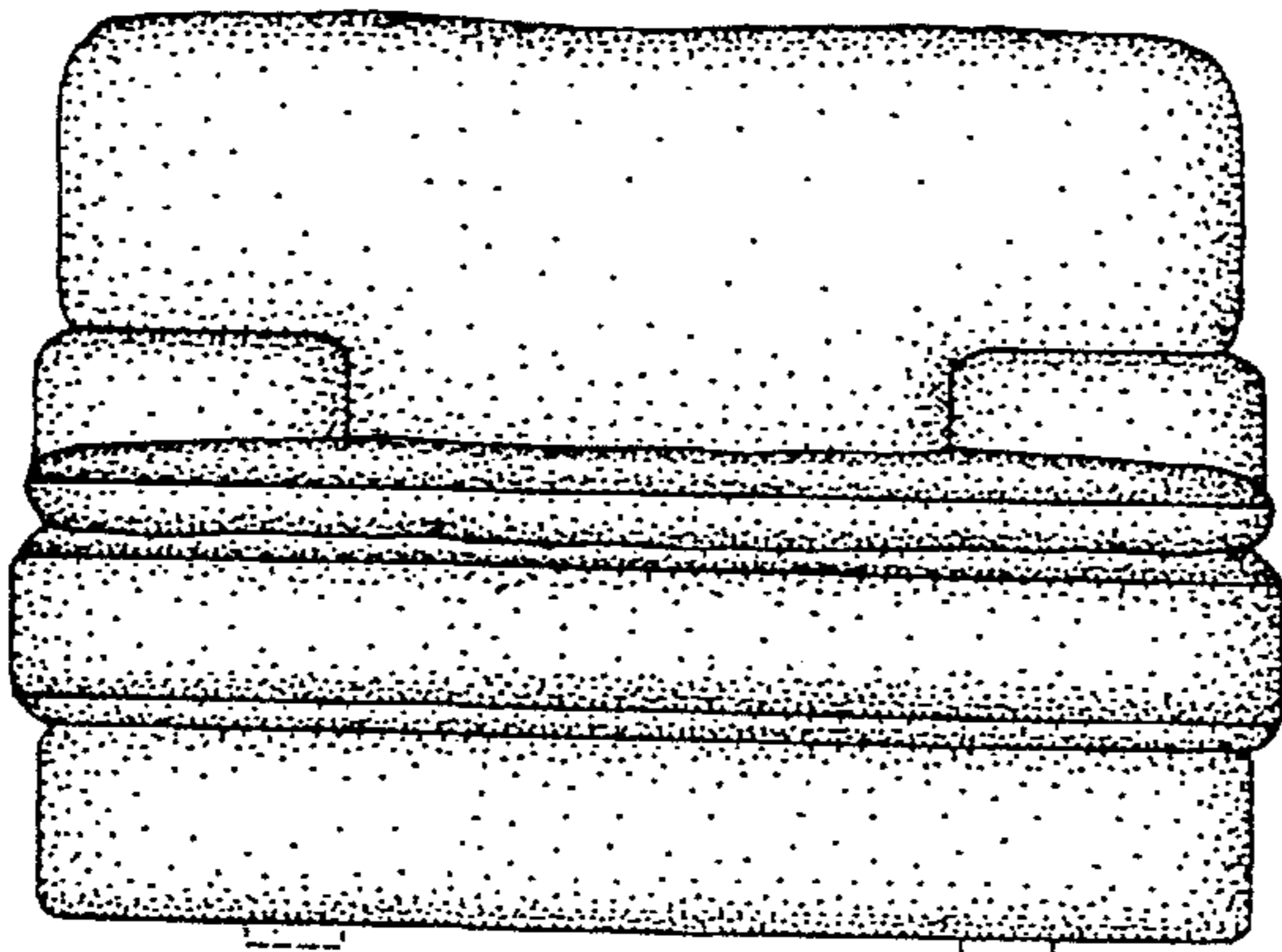

FIG-7