



US00D372785S

United States Patent [19]

[11] Patent Number: **Des. 372,785**

Sabri et al.

[45] Date of Patent: ****Aug. 13, 1996**

[54] **EXTERNAL LEAD ADAPTOR FOR WRIST-WORN CARDIAC MONITOR**

Attorney, Agent, or Firm—Kolisch Hartwell Dickinson McCormack & Heuser

[75] Inventors: **Mohamed Sabri**, Beaverton; **Colin M. Portnuff**, Tualatin, both of Oreg.

[57] **CLAIM**

The ornamental design for an external lead adaptor for wrist-worn cardiac monitor, as shown and described.

[73] Assignee: **Instromedix, Inc.**, Hillsboro, Oreg.

DESCRIPTION

[**] Term: **14 Years**

[21] Appl. No.: **33,418**

[22] Filed: **Jan. 12, 1995**

[52] U.S. Cl. **D24/167**

[58] Field of Search D24/187, 167;
128/689, 690, 696, 702

FIG. 1 is an isometric view of an external lead adaptor for wrist-worn cardiac monitor showing our new design; FIG. 2 is a top plan view thereof shown on a slightly larger scale than FIG. 1;

FIG. 3 is a right side elevation thereof, shown on approximately the same scale as in FIG. 2, the left side elevation thereof being a mirror image, with the heart watch and a flexible electrical conductor shown in broken lines for illustrative purposes only and forming no part of the claimed design;

FIG. 4 is a front elevation thereof, shown on approximately the same scale as in FIG. 2;

FIG. 5 is a rear elevation thereof, shown on approximately the same scale as in FIG. 2;

FIG. 6 is a bottom plan view thereof, shown on approximately the same scale as in FIG. 2; and,

FIG. 7 is a perspective view thereof, with the viewpoint on the opposite side of the adaptor and at a lower elevation than shown in FIG. 1, and the adaptor shown on approximately the same scale as in FIG. 1.

[56] **References Cited**

U.S. PATENT DOCUMENTS

4,052,979	10/1977	Scherr et al. .	
4,129,125	12/1978	Lester et al. .	
4,258,719	3/1981	Lewyn .	
4,295,472	10/1981	Adams .	
4,450,843	5/1984	Barney et al. .	
4,513,753	4/1985	Tabata et al. .	
4,635,646	1/1987	Gilles et al. .	
4,807,639	2/1989	Shimizu et al.	126/690
5,226,425	7/1993	Righter .	
5,289,824	3/1994	Mills et al. .	
5,365,935	11/1994	Righter et al. .	

Primary Examiner—Stella Reid

1 Claim, 2 Drawing Sheets

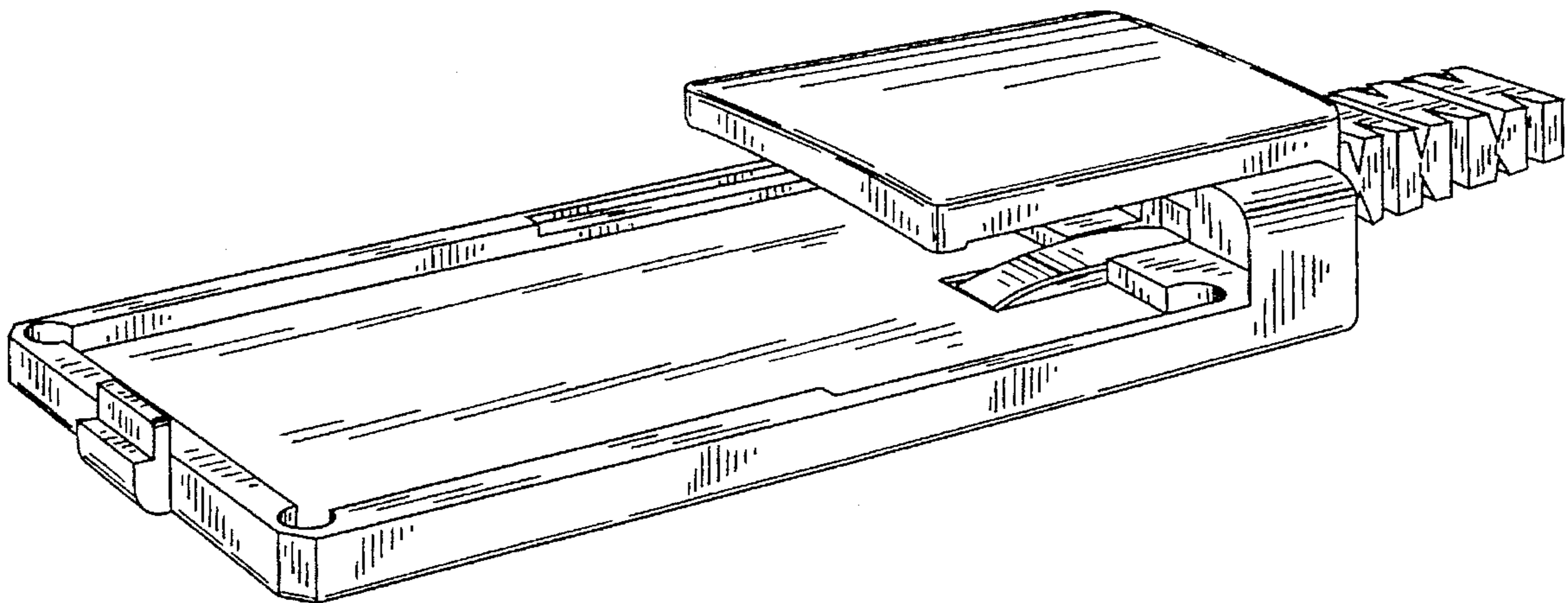

FIG. 1

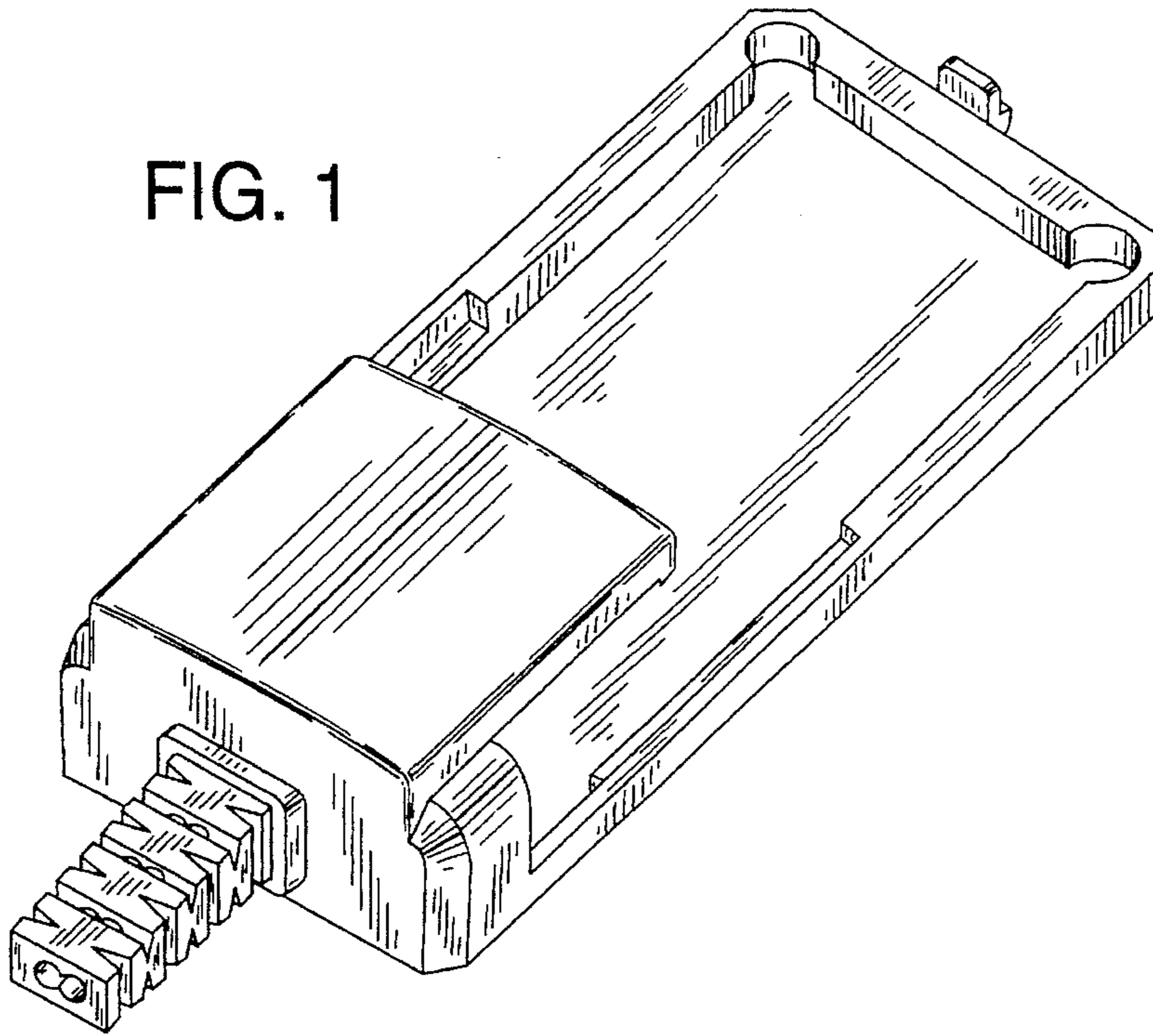

FIG. 2

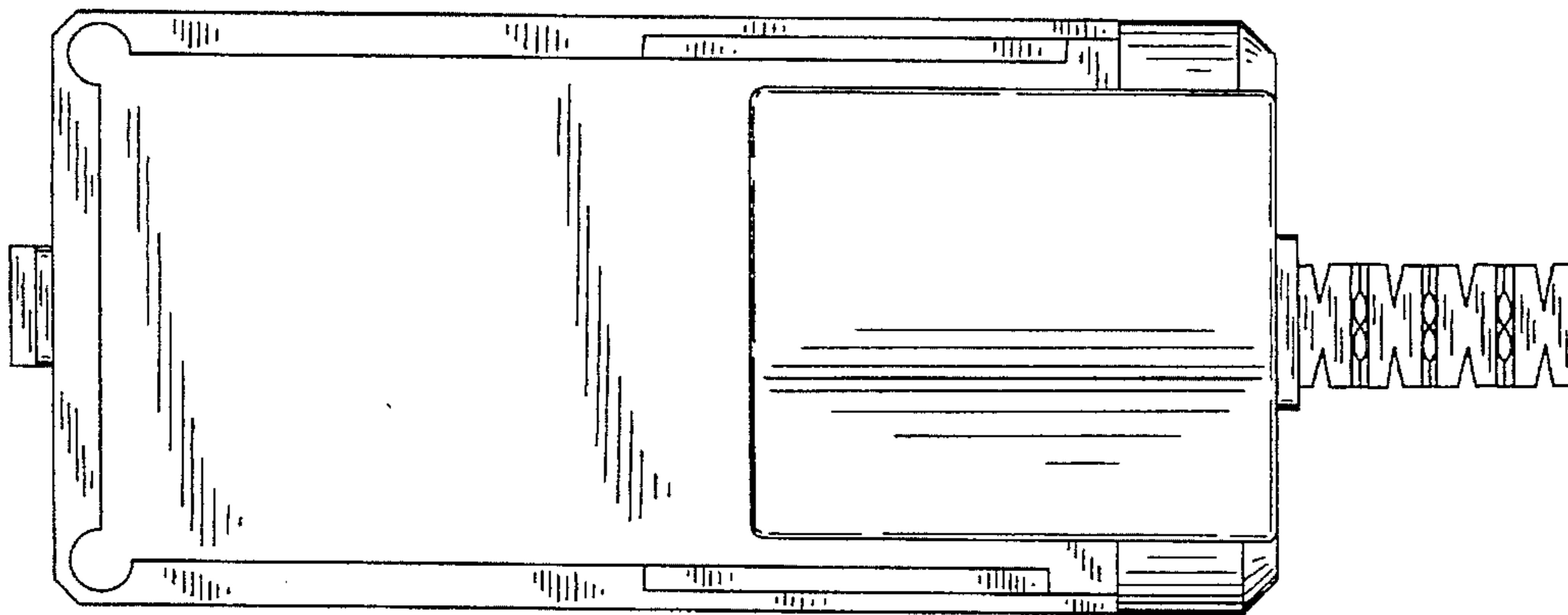

FIG. 3

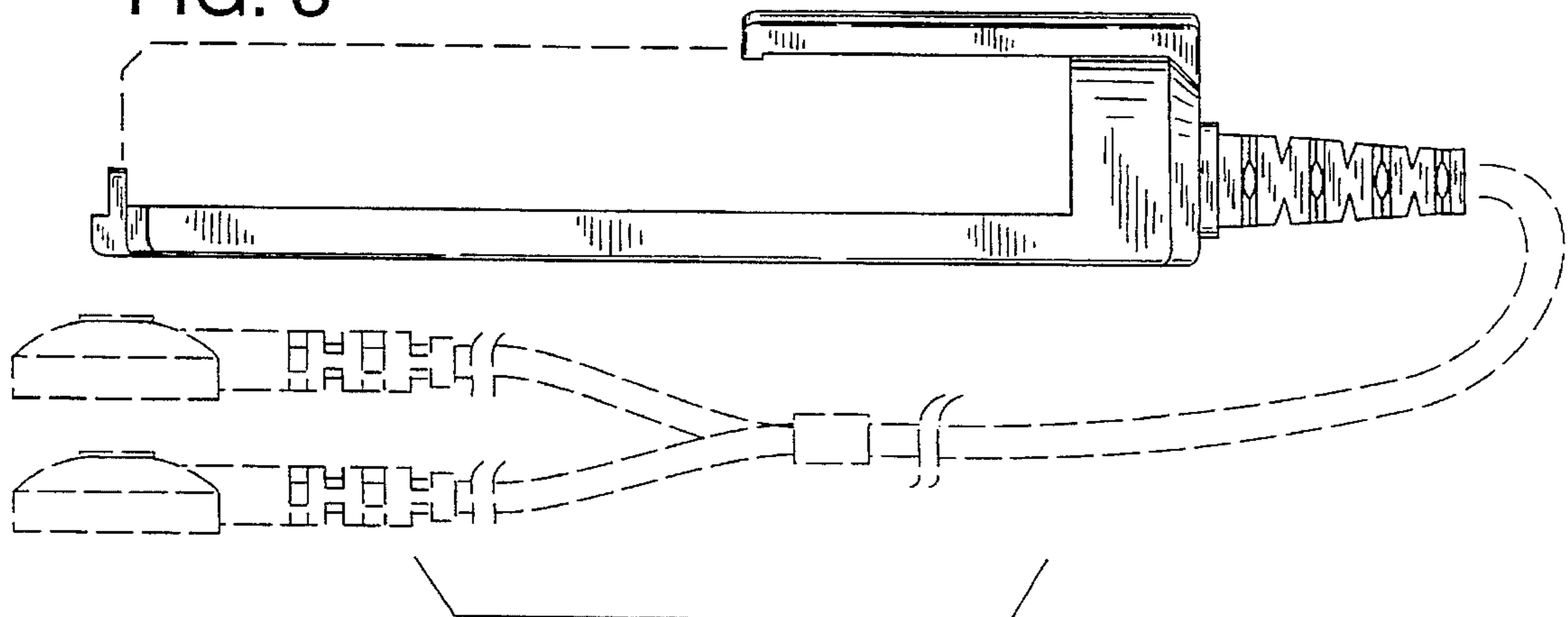

FIG. 4

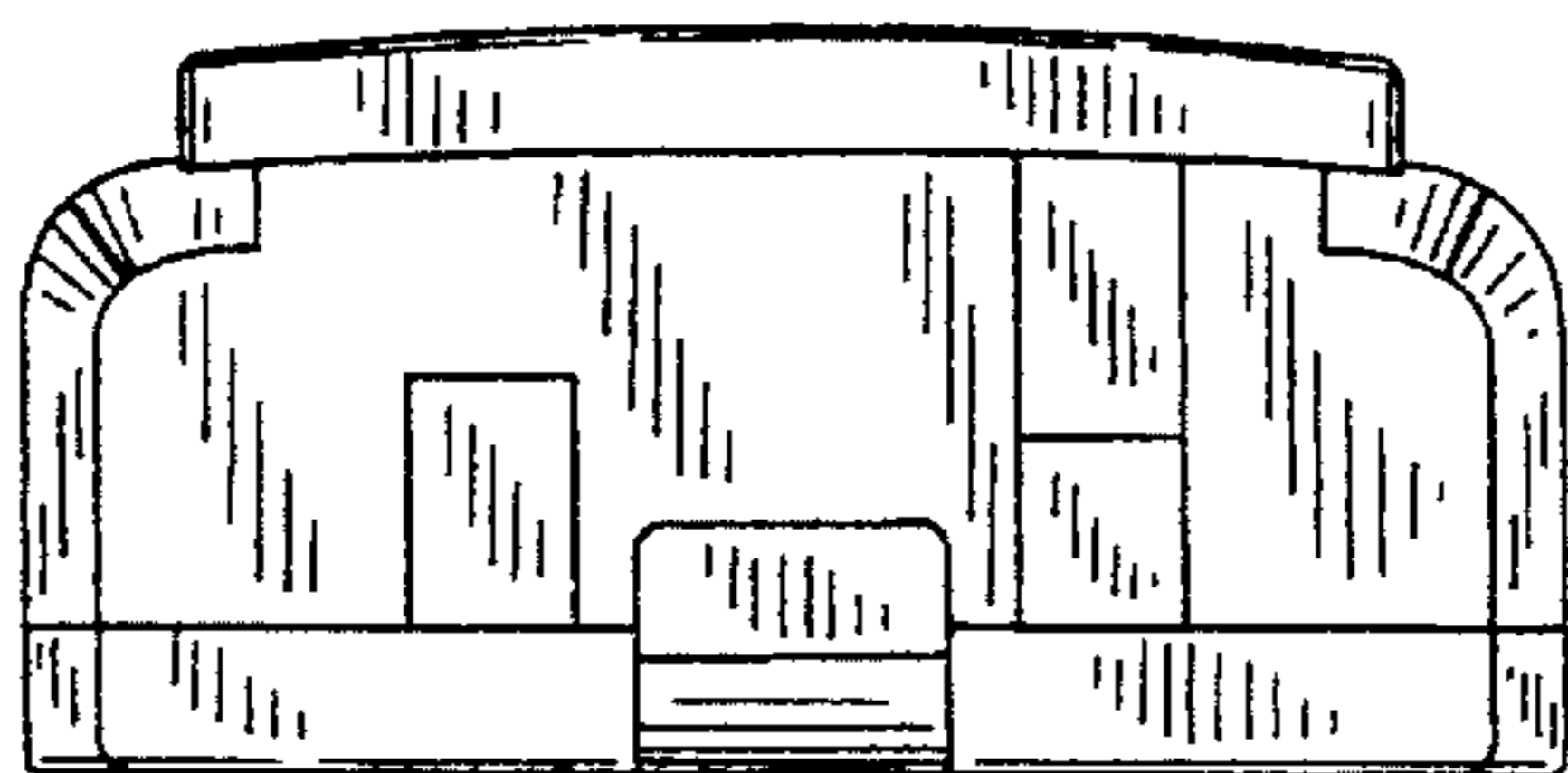

FIG. 5

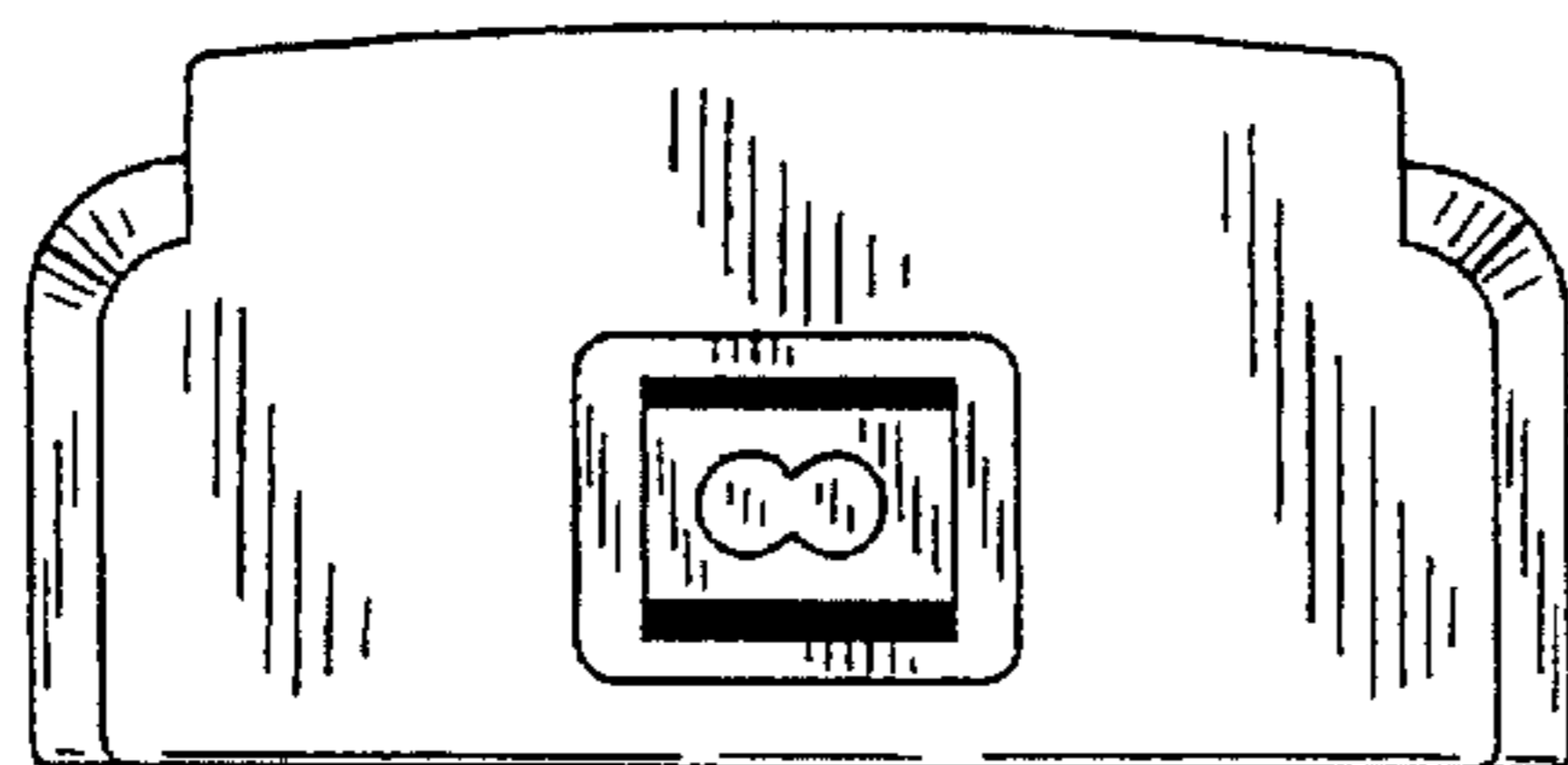

FIG. 6

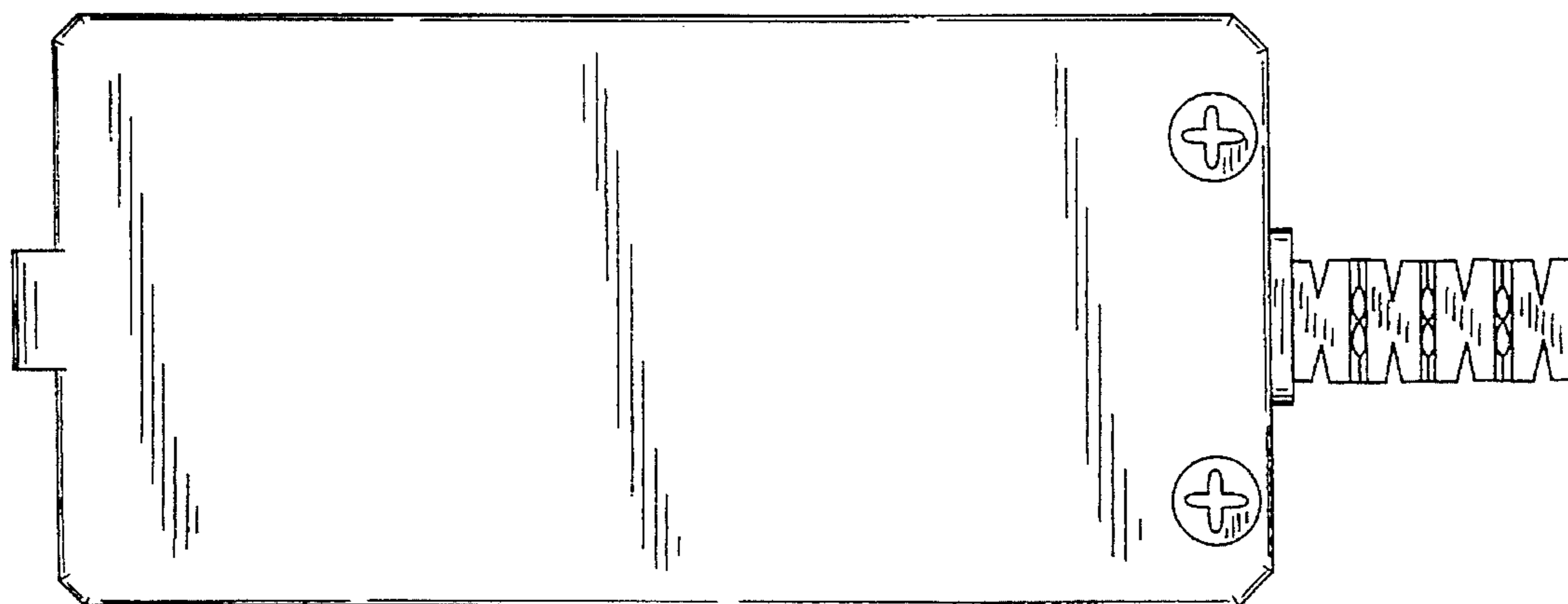

FIG. 7

