



US00D372689S

United States Patent [19]

[11] Patent Number: **Des. 372,689**

Sacco et al.

[45] Date of Patent: ****Aug. 13, 1996**

[54] **MOTOR VEHICLE EXTERIOR BODY**

[75] Inventors: **Bruno Sacco; Josef Gallitzendoerfer**, both of Sindelfingen; **Peter Pfeiffer**, Boeblingen; **Murat Guenak**, Ehningen, all of Germany

[73] Assignee: **Mercedes-Benz AG**, Stuttgart, Germany

[**] Term: **14 Years**

[21] Appl. No.: **20,674**

[22] Filed: **Mar. 30, 1994**

[30] **Foreign Application Priority Data**

Sep. 30, 1993 [DE] Germany M9307572.3

[52] U.S. Cl. **D12/92**

[58] Field of Search D12/82-3, 86, D12/88-92; D21/78; 296/185-6

[56] **References Cited**

U.S. PATENT DOCUMENTS

D. 233,321 10/1974 Wilfert D12/92
D. 351,573 10/1994 Kong et al. D12/92

OTHER PUBLICATIONS

Autocar and Motor, Alfa Romeo Spider and RZ, Oct. 72, 1992, p. 5.

Autocar & Motor, Audi Cabriolet, Jun. 17, 1992, p. 11.

Car and Driver, Mercedes 190 class, Jun. 1992, p. 27.

Car and Driver, BMW 325i convertible, Aug. 1993, p. 68.

Primary Examiner—M. H. Tung

Attorney, Agent, or Firm—Evenson, McKeown Edwards & Lenahan

[57] **CLAIM**

The ornamental design for a motor vehicle exterior body, as shown and described.

DESCRIPTION

FIG. 1 is a front view of a motor vehicle exterior body with

the top up according to our novel design;

FIG. 2 is a front view of a motor vehicle exterior body, with the top down;

FIG. 3 is a right side view of a motor vehicle exterior body, with the top up;

FIG. 4 is a right side view of a motor vehicle exterior body, with the top down;

FIG. 5 is a left side view of a motor vehicle exterior body, with the top up;

FIG. 6 is a left side view of a motor vehicle exterior body, with the top up;

FIG. 7 is a front, left side perspective view of a motor vehicle exterior body, with the top up;

FIG. 8 is a front, left side perspective view of a motor vehicle exterior body, with the top down;

FIG. 9 is a rear, left side perspective view of a motor vehicle exterior body, with the top up;

FIG. 10 is a rear, left side perspective view of a motor vehicle exterior body, with the top down;

FIG. 11 is a rear view of a motor vehicle exterior body, with the top up;

FIG. 12 is a rear view of a motor vehicle exterior body, with the top down;

FIG. 13 is a top view of a motor vehicle exterior body, with the top up; and,

FIG. 14 is a top view of a motor vehicle exterior body, with the top up.

The dash line representations in the drawings are included for showing the environment and are not part of the claimed design.

1 Claim, 10 Drawing Sheets

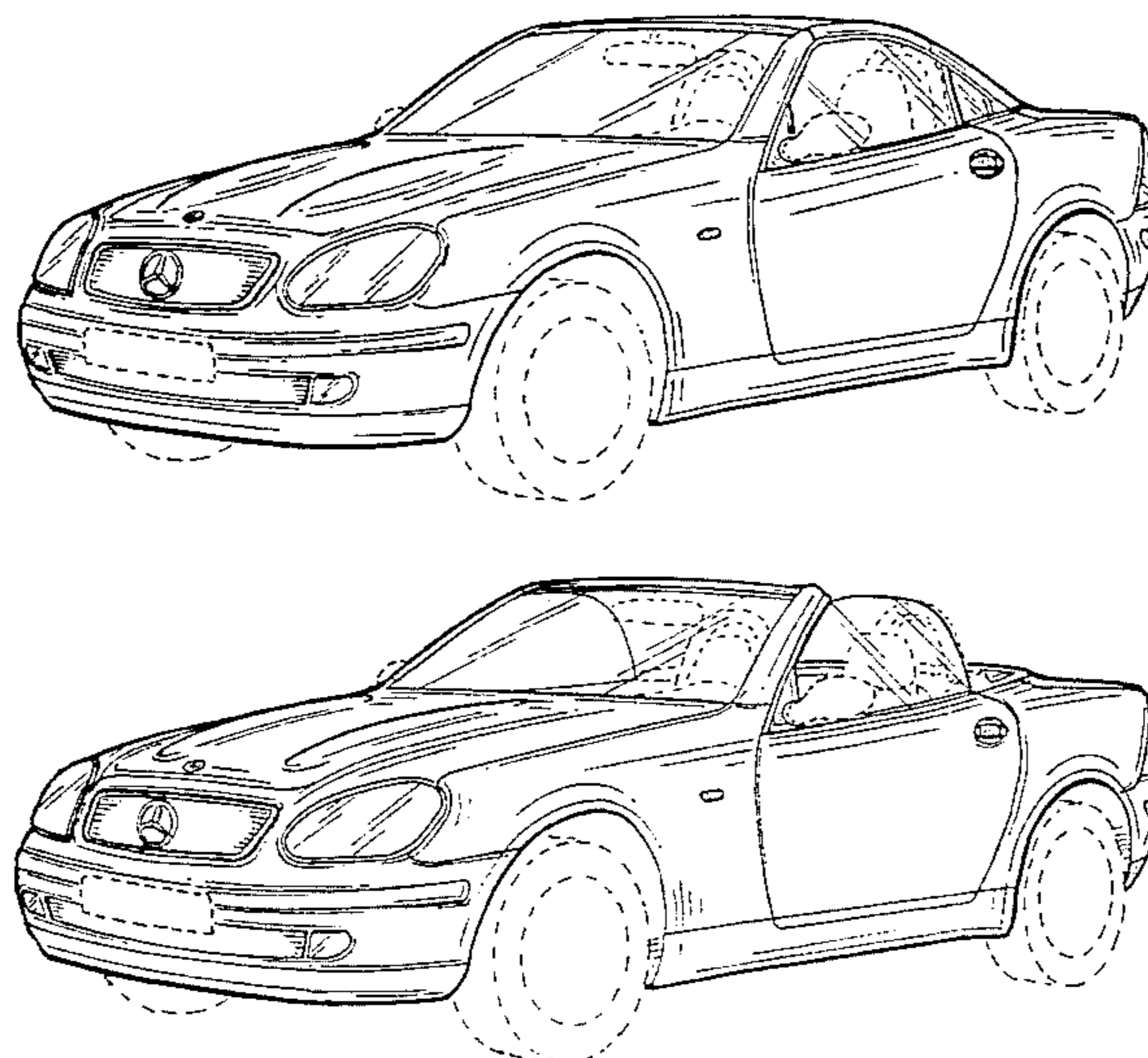

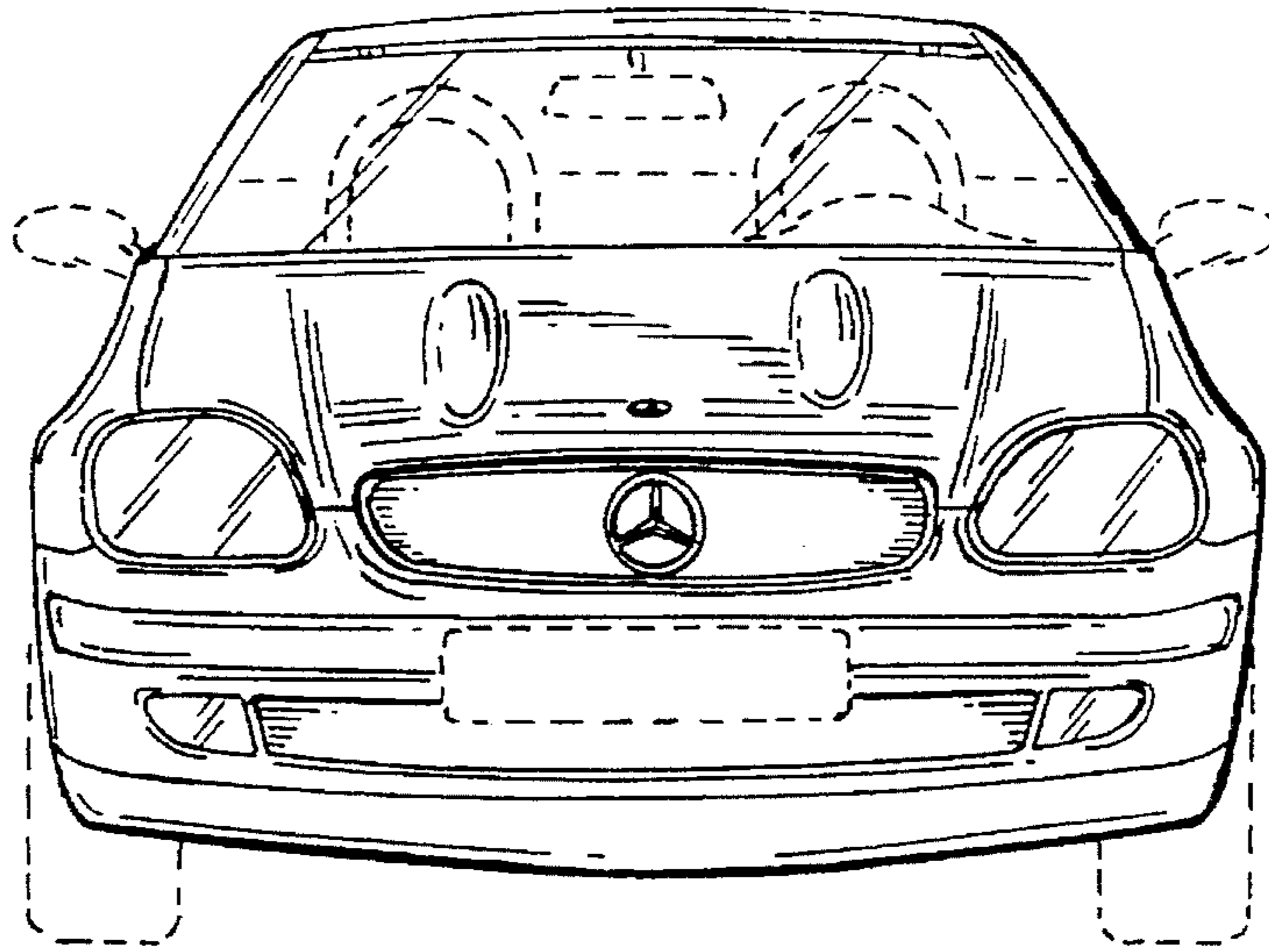

FIG. 1

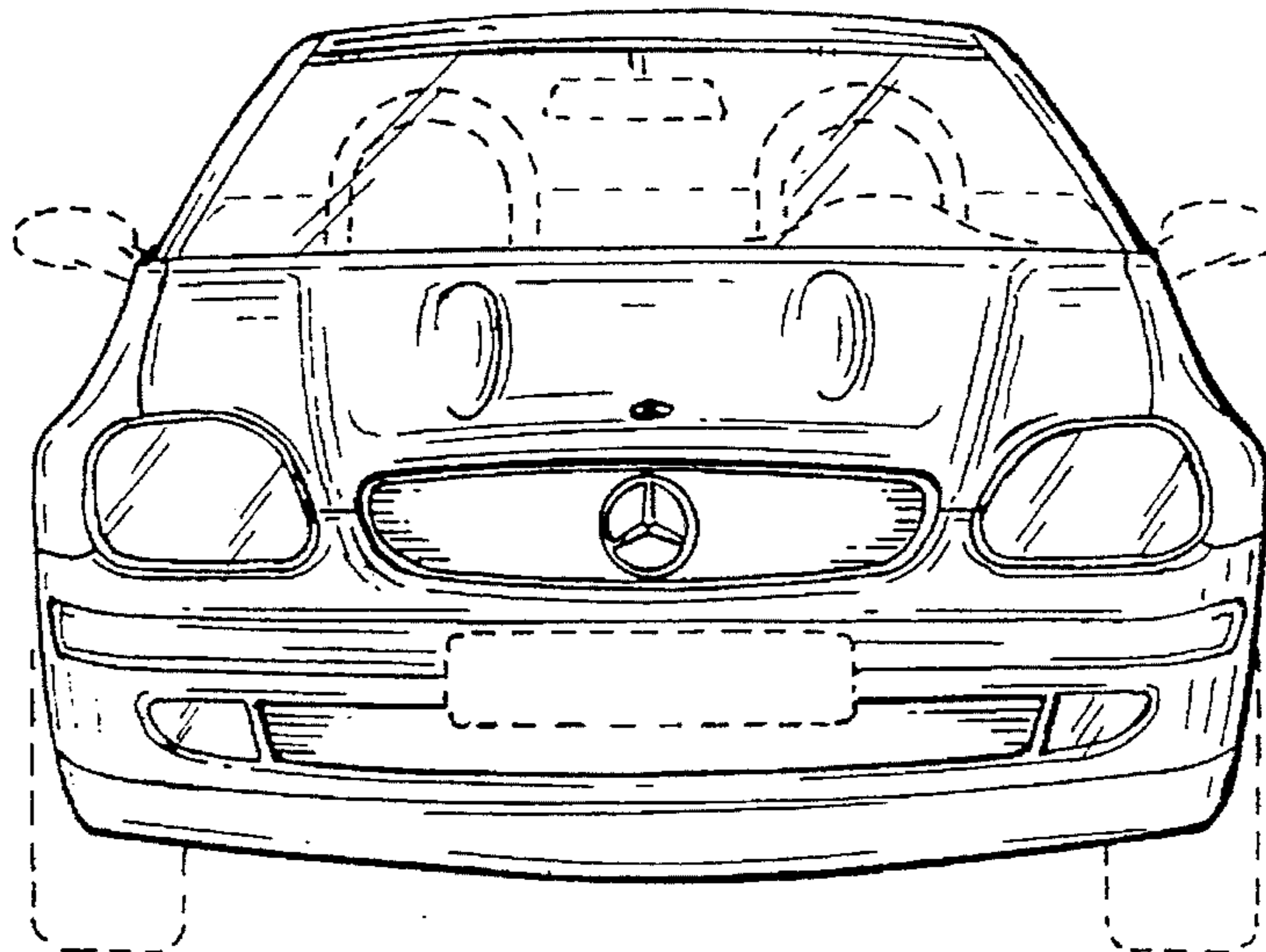

FIG. 2

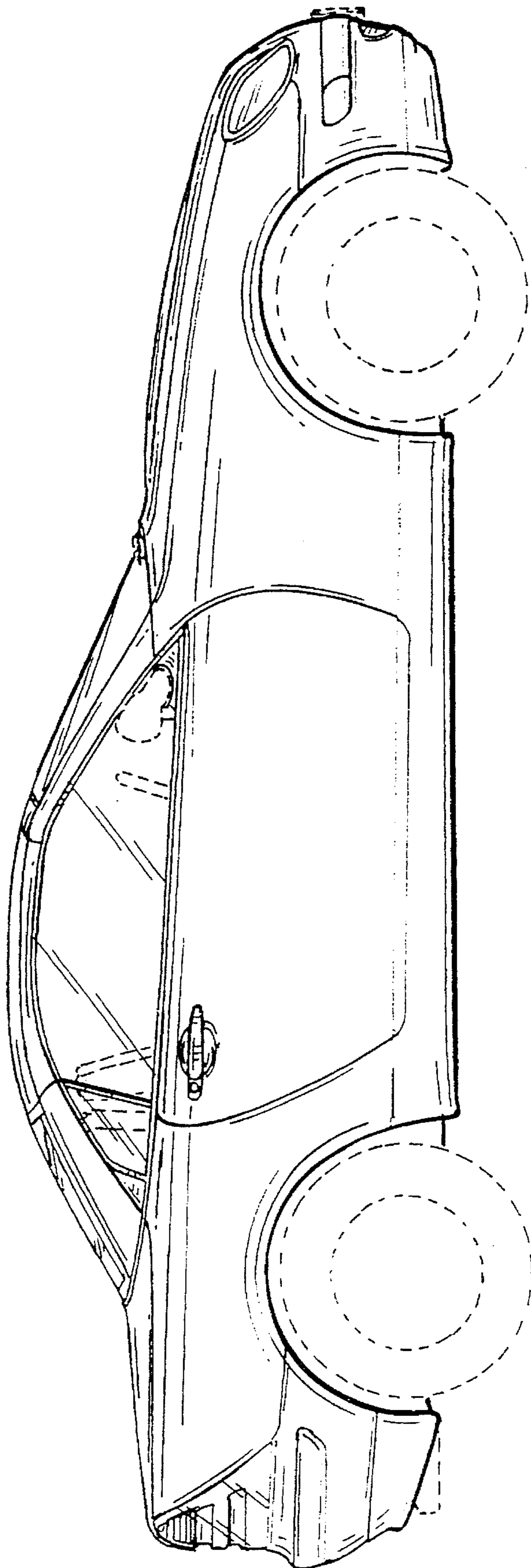

FIG. 3

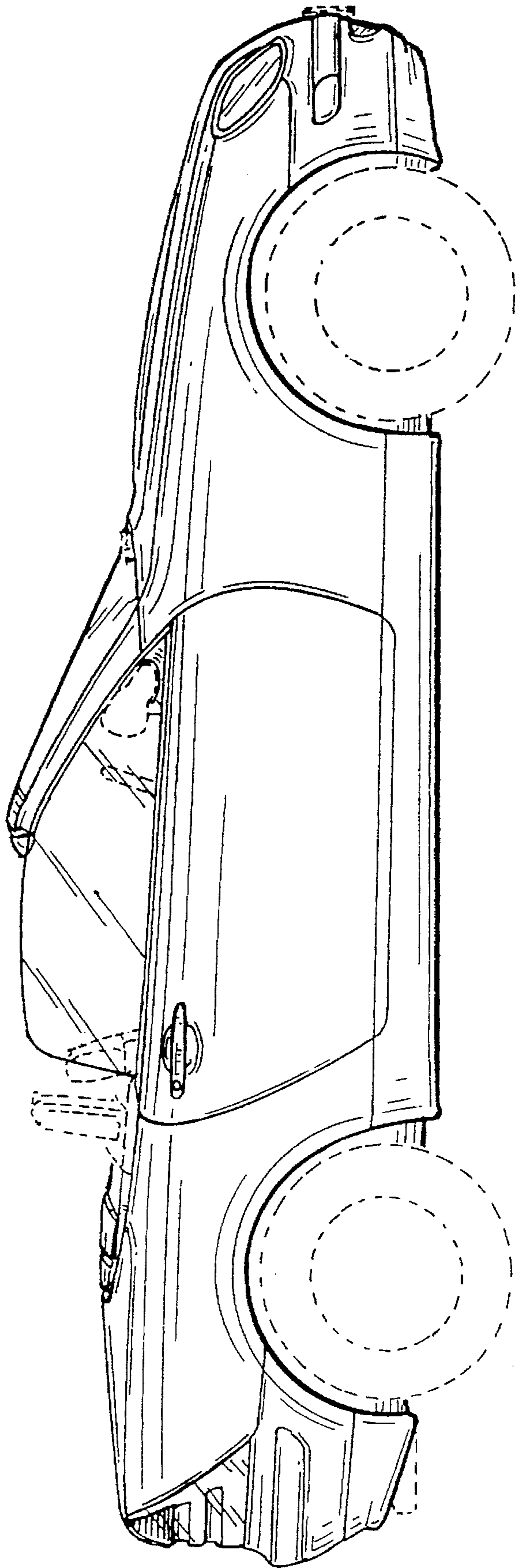

FIG. 4

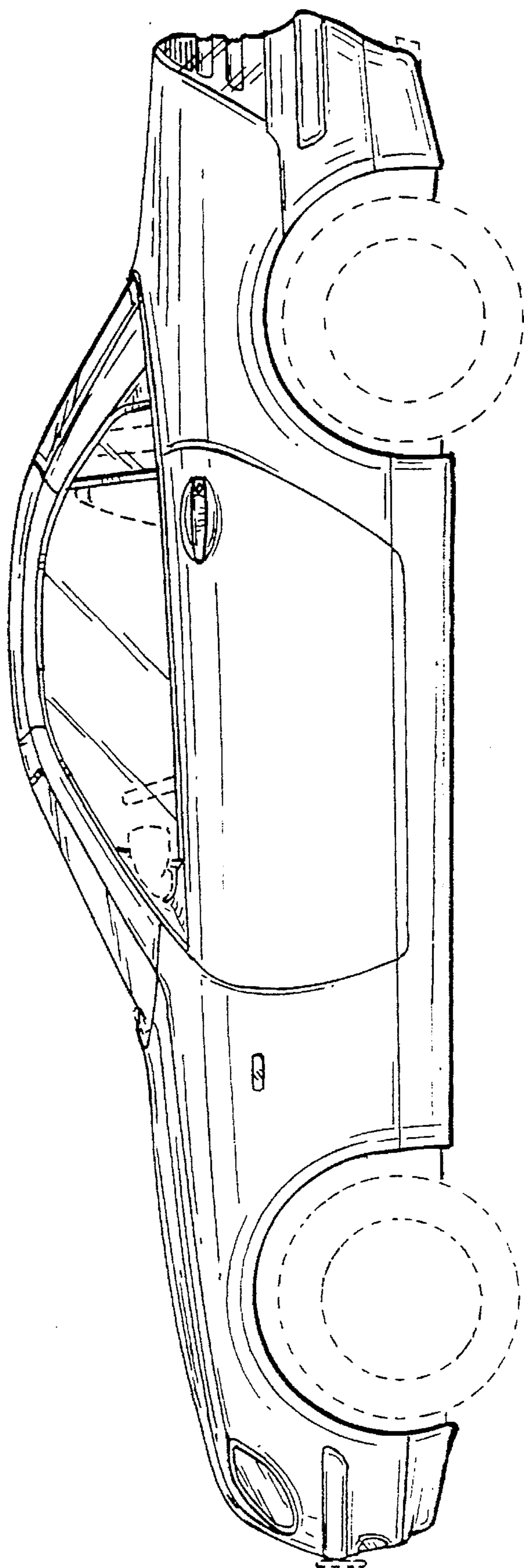

FIG. 5

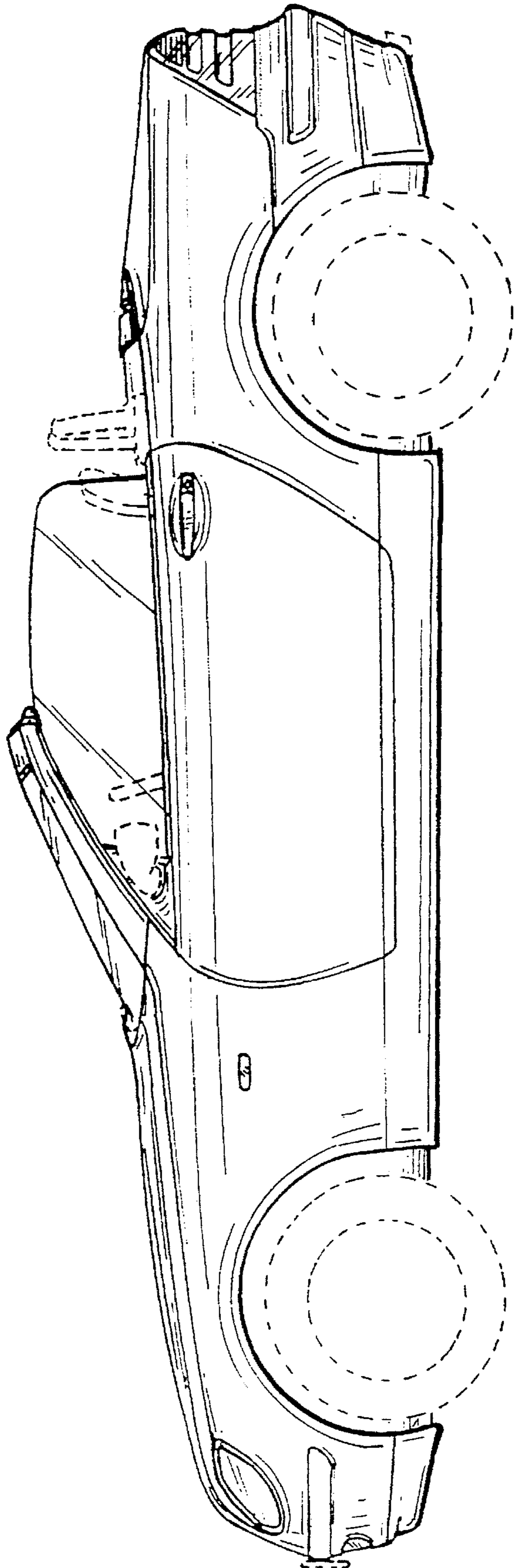

FIG. 6

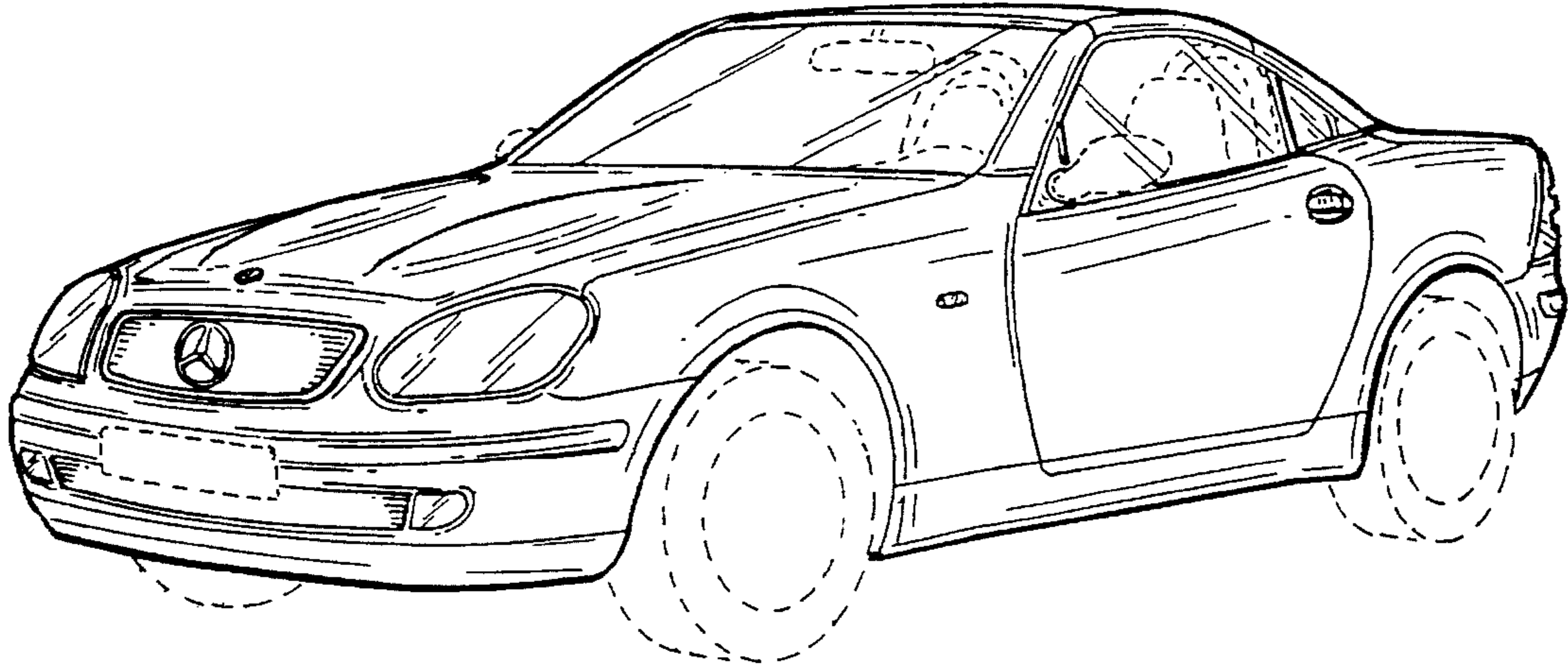

FIG. 7

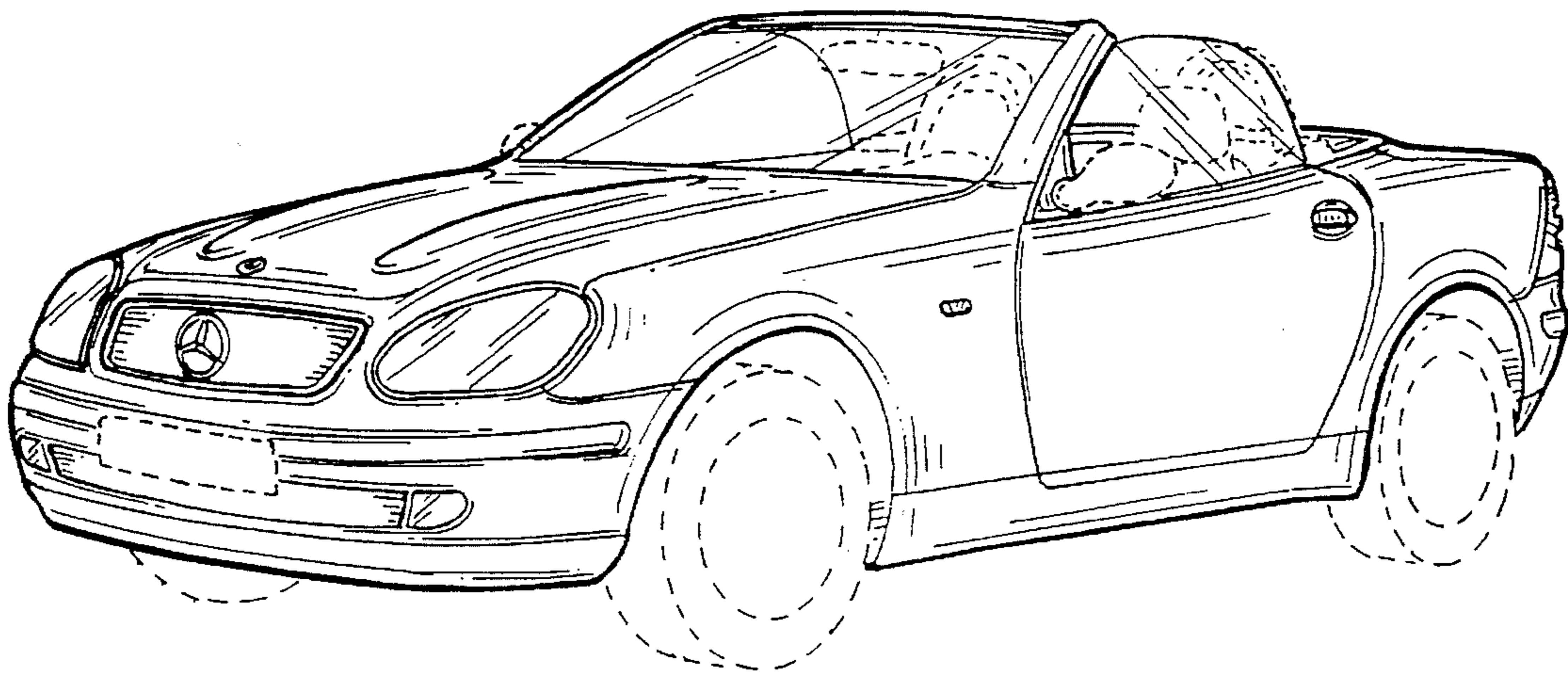

FIG. 8

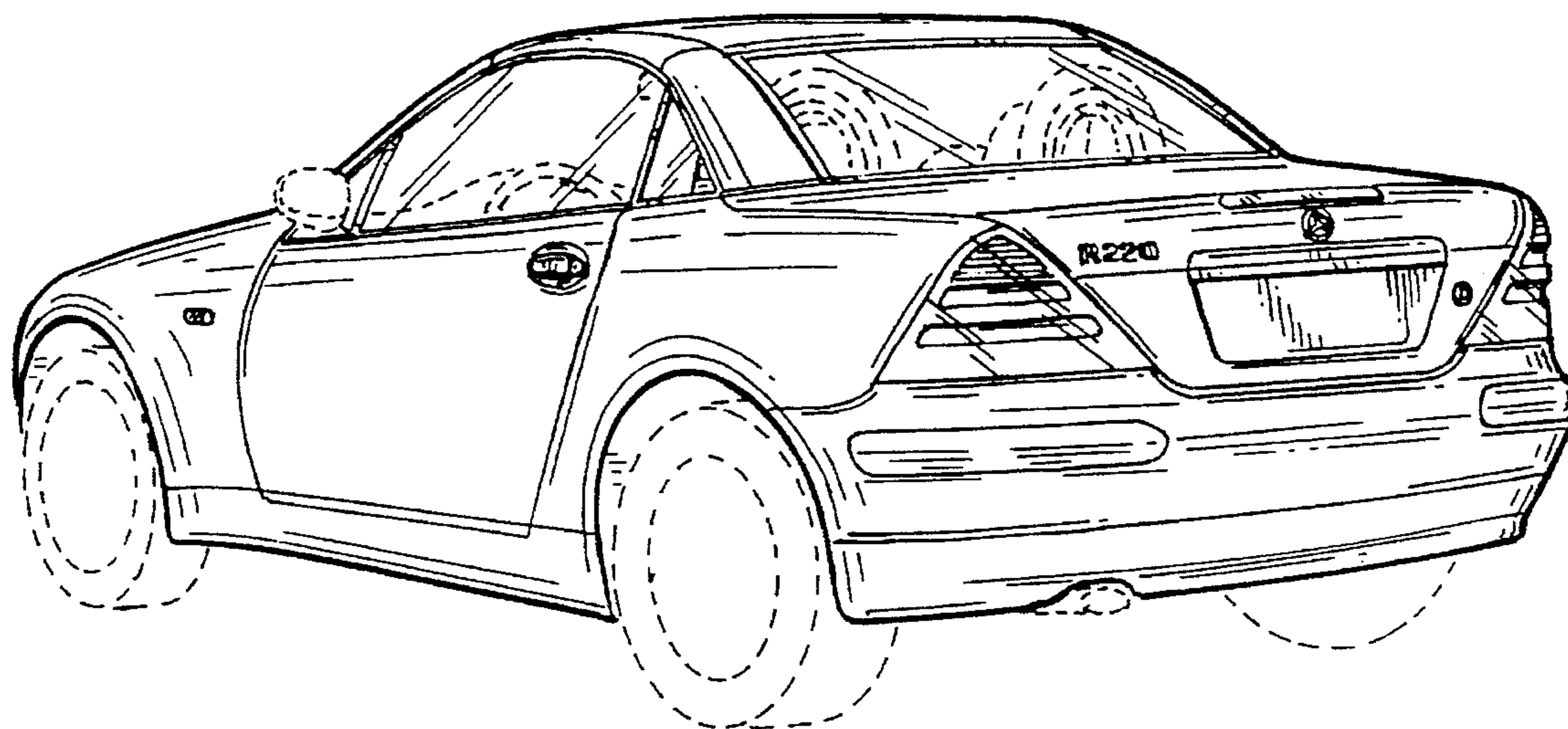

FIG. 9

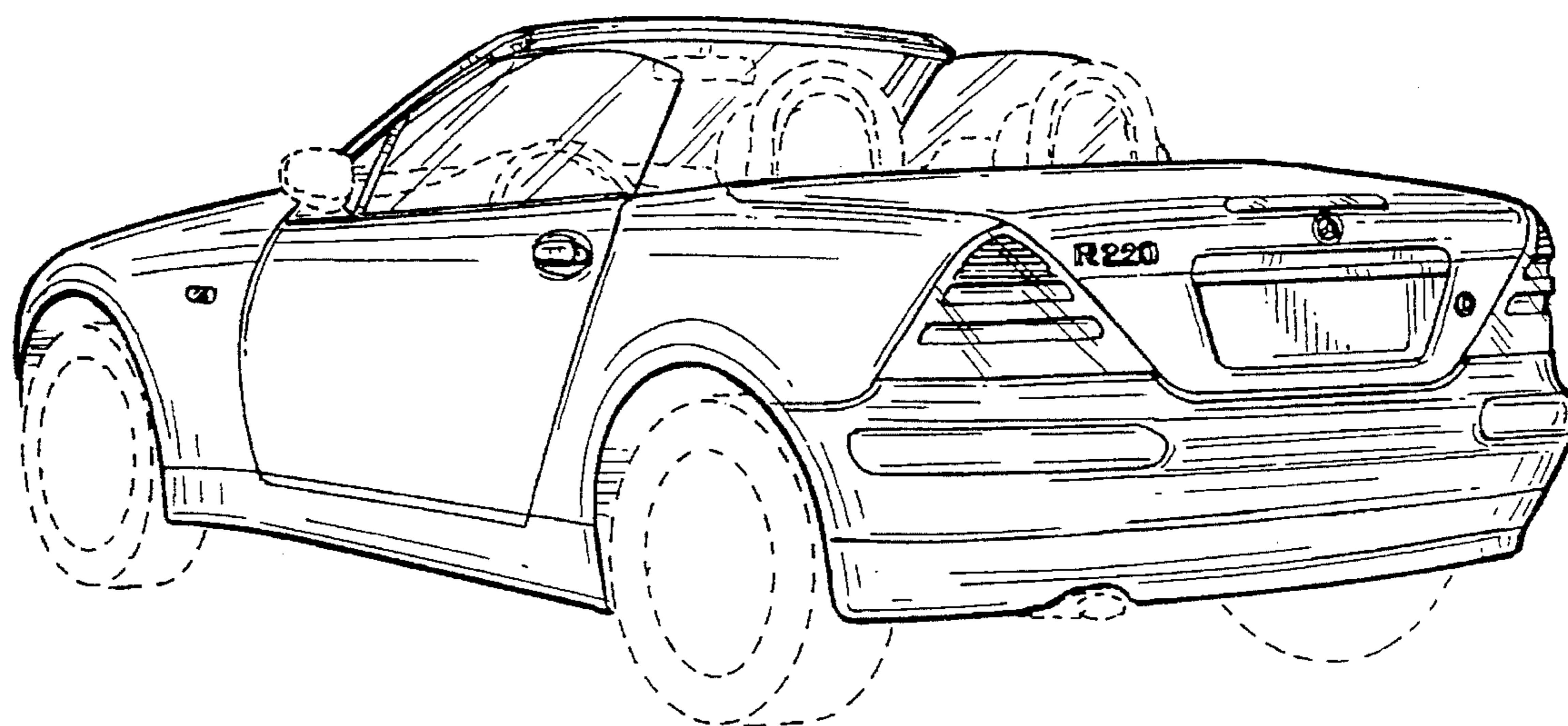

FIG. 10

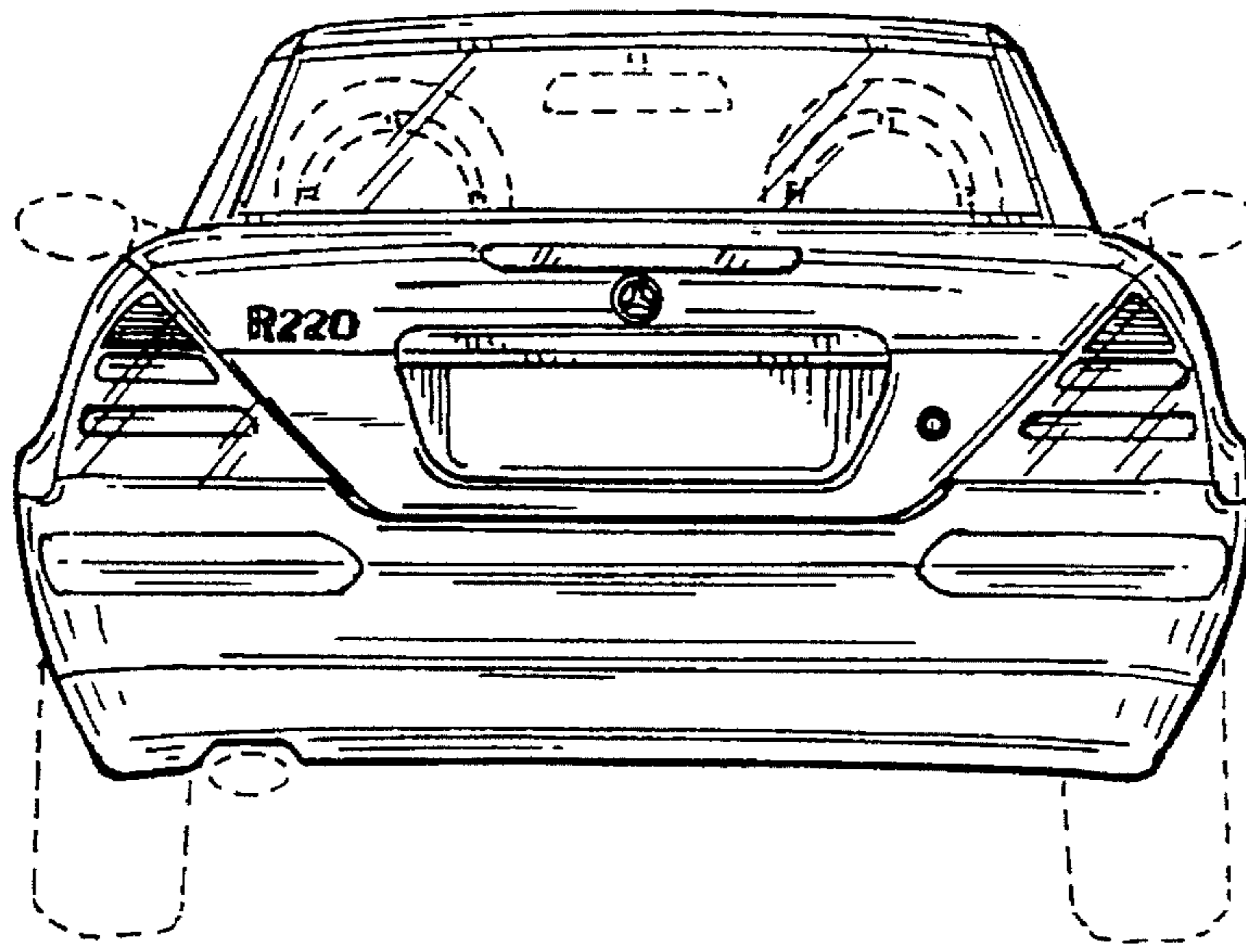

FIG. 11

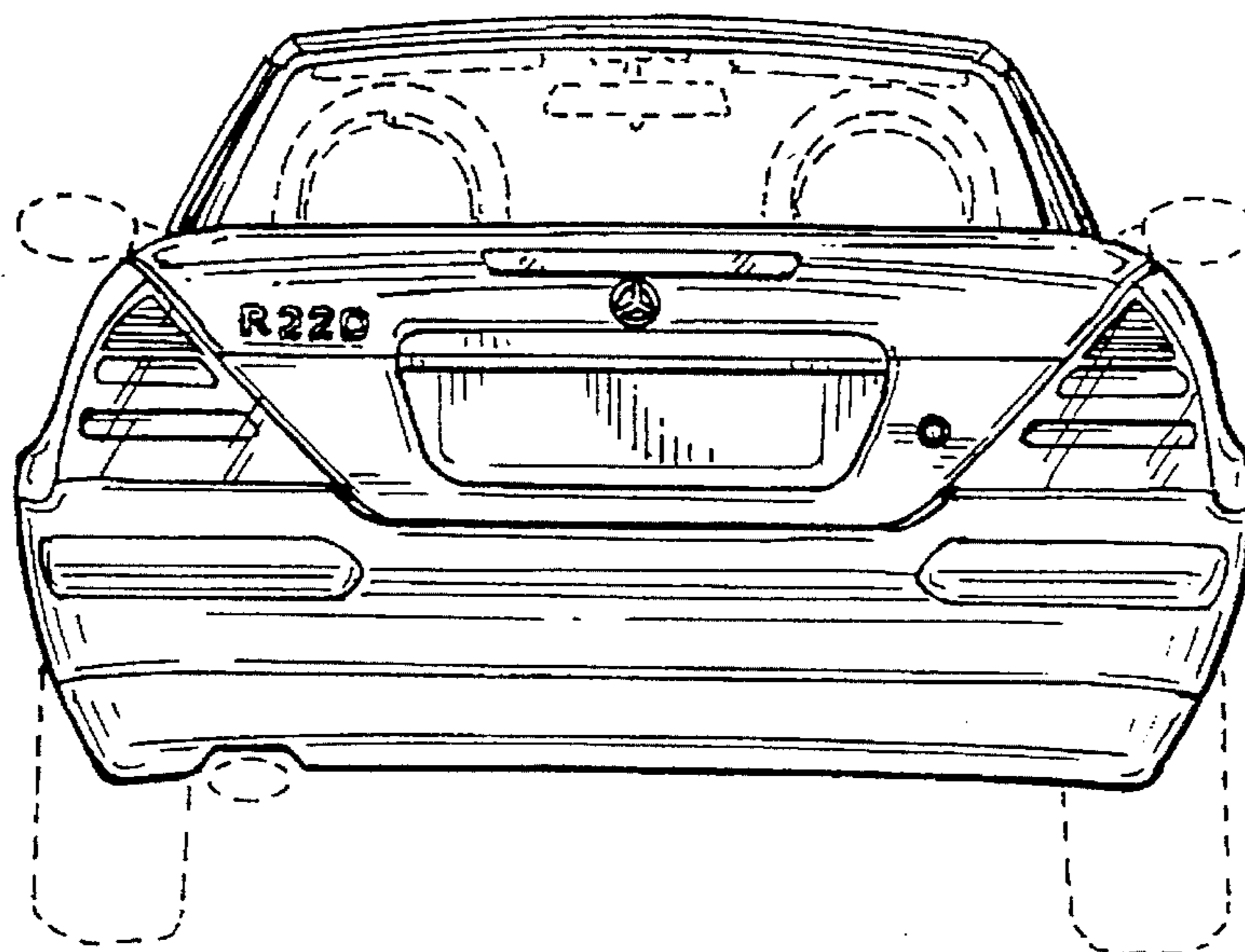

FIG. 12

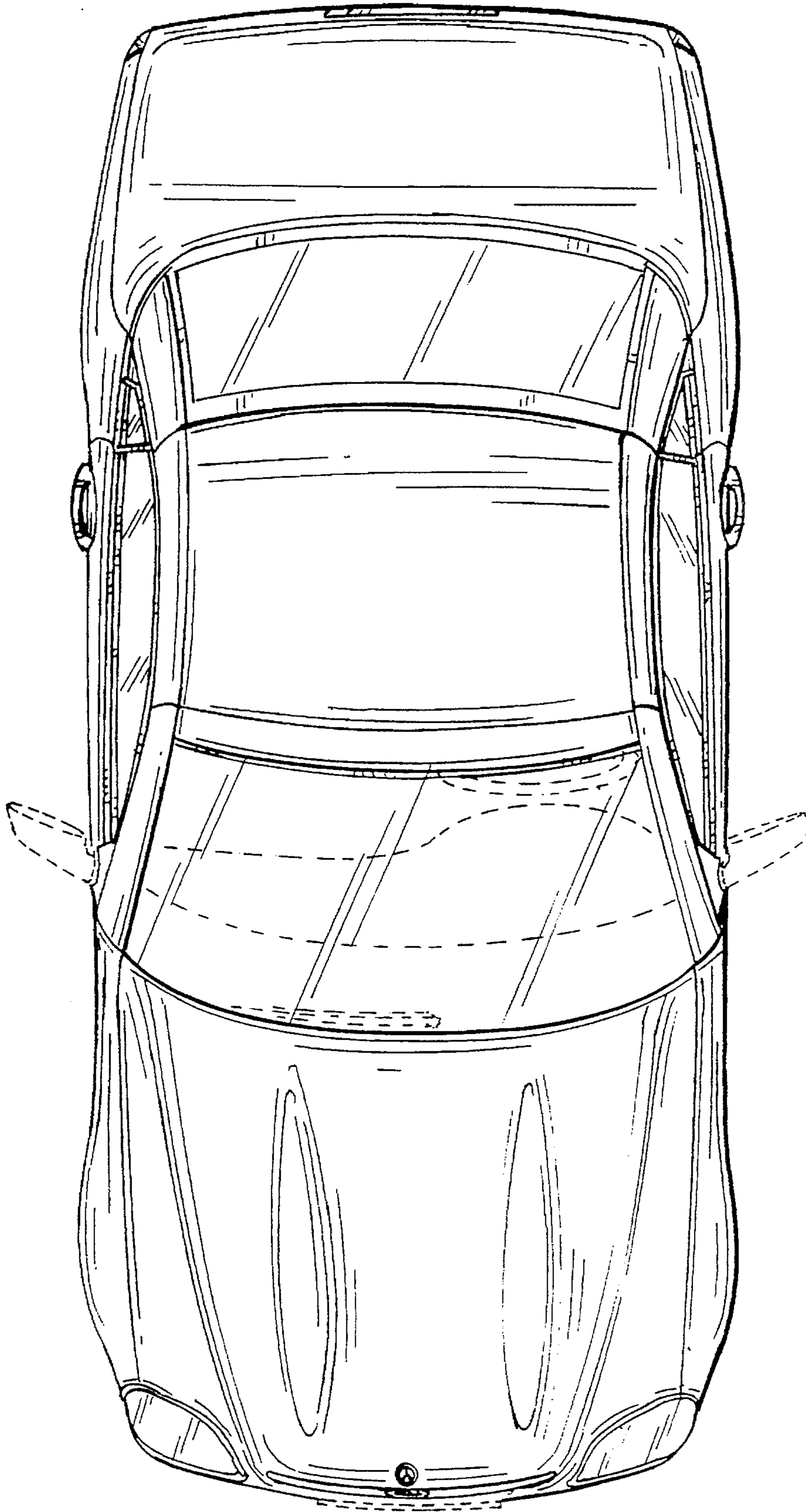

FIG. 13

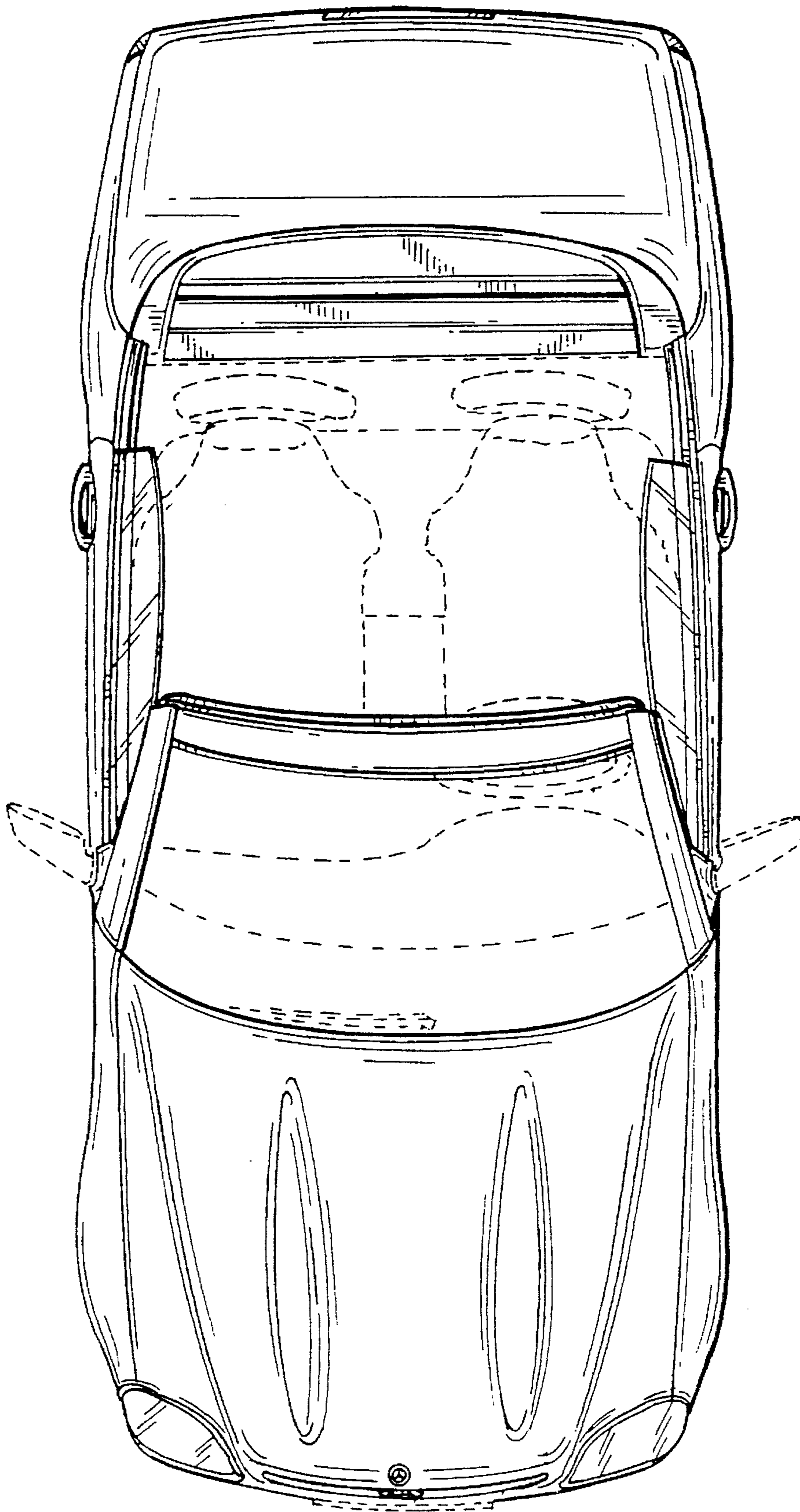

FIG.14